

FRONT SUSPENSION AND DRIVE SHAFTS

CONTENTS

	page		page
DRIVESHAFTS	26	GENERAL INFORMATION	1
FRONT SUSPENSION	2	SPECIFICATIONS	46
FRONT SUSPENSION SERVICE PROCEDURES .	6		

GENERAL INFORMATION

Throughout this group, references may be made to a particular vehicle by letter or number designation. A chart showing the breakdown of these designations is included in the Introduction section at the front of this Service Manual.

An independent MacPherson Type front suspension is used on these vehicles. Vertical shock absorbing struts attach to the upper fender reinforcement and

the steering knuckle to provide upper steering knuckle position. Lower control arms are attached inboard to a crossmember and outboard to the steering knuckle through a ball joint to provide lower steering knuckle position. During steering maneuvers, the strut (through a pivot bearing in the upper retainer) and the steering knuckle turn as an assembly (Fig. 1).

1. FRONT SUSPENSION CROSSMEMBER
2. FRONT PIVOT BOLT
3. LOWER CONTROL ARM
4. SWAY ELIMINATOR SHAFT ASSEMBLY
5. LOWER ARM BALL JOINT ASSEMBLY
6. STEERING GEAR
7. TIE ROD ASSEMBLY
8. DRIVESHAFT
9. STEERING KNUCKLE
10. STRUT DAMPER ASSEMBLY
11. COIL SPRING
12. UPPER SPRING SEAT
13. REBOUND STOP
14. UPPER MOUNT ASSEMBLY
15. JOUNCE BUMPER
16. DUST SHIELD

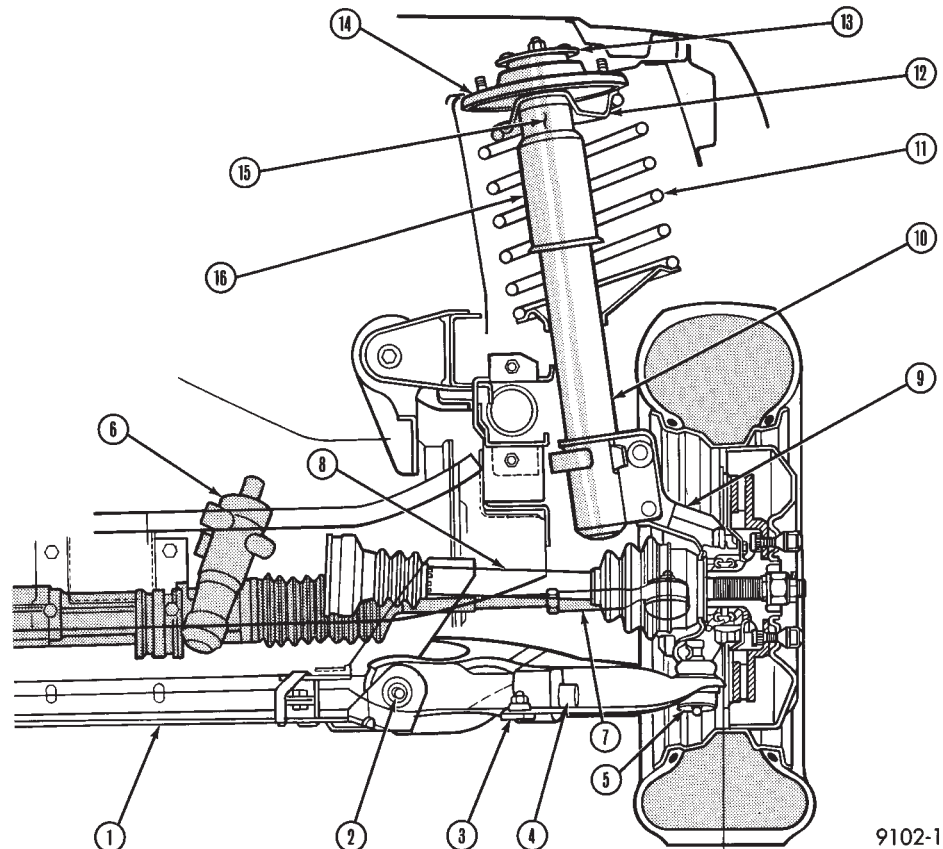

9102-1

Fig. 1 Front Suspension (Typical)

FRONT SUSPENSION

FRONT SUSPENSION MAJOR COMPONENTS (Fig. 1, 2 and 3)*STRUT SUPPORT*

The system is supported by coil springs positioned offset around the struts. The springs are contained between an upper seat, located just below the top strut mount assembly (Fig. 2) and a lower spring seat on the strut lower housing.

The top of each strut assembly is bolted to the upper fender reinforcement (shock tower) through a rubber isolated mount.

The bottom attaches to the top of the steering knuckle with two through bolts. On some vehicles, one bolt has an eccentric cam located below the head of the bolt for camber adjustment. On the other vehicles the camber adjustment is done by manually moving the steering knuckle within the strut assembly. Caster is a fixed setting on all vehicles and is not adjustable.

STEERING KNUCKLE

The steering knuckle is a single casting with legs machined for attachment to the strut damper, steering linkage, brake adaptor, and lower control arm ball joint. The knuckle also holds the front drive hub bearing. The hub is positioned through the bearing and knuckle, with the constant velocity stub shaft splined through the hub.

LOWER CONTROL ARM

The lower control arm is a steel casting with 2 large spool type rubber pivot bushings. The lower control arm is bolted to the crossmember with pivot bolts through the center of the rubber pivot bushings.

The ball joint is pressed into the control arm and has a non-tapered stud with a notch for clamp bolt clearance. The stud is clamped and locked into the steering knuckle leg with a clamp bolt.

The lower control arms are inter-connected through a rubber isolated sway bar (Fig. 2).

DRIVESHAFTS

A left and right driveshaft is attached inboard to the transaxle differential side gears, and outboard to the driven wheel hub.

To deliver driving force from the transaxle to the front wheels during turning maneuvers and suspension movement. Both shafts are constructed with constant velocity universal joints at both ends.

Both shafts have a Tripod (sliding) joint at the transaxle end and Rzeppa joints (with splined stub shafts) on the hub ends. Due to the transaxle location the connecting shafts between the C/V joints are of different length and construction. The right shaft is longer and of tubular construction. The left shaft is solid.

9202-80

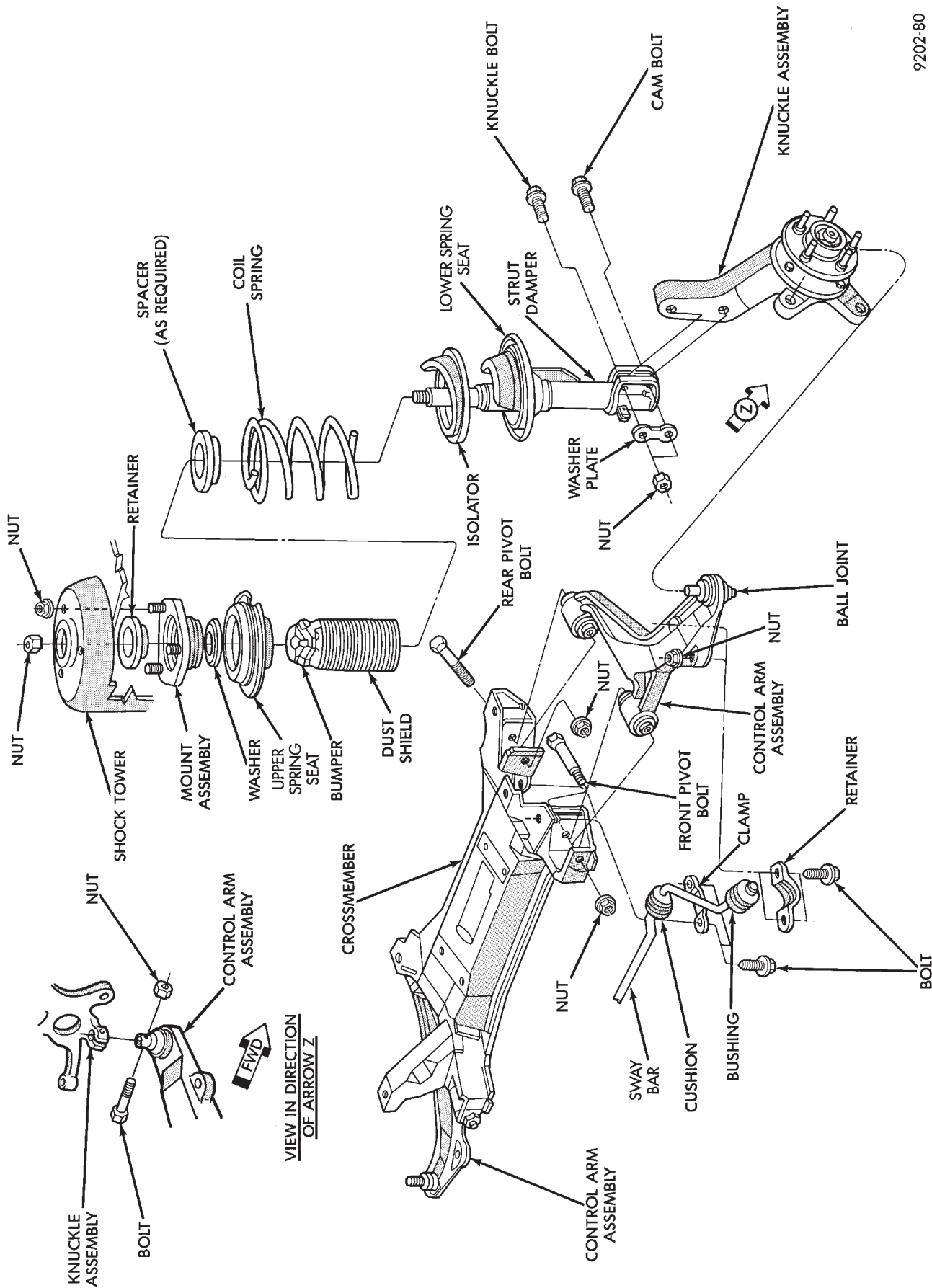

Fig. 2 Front Suspension (F.W.D.) Typical

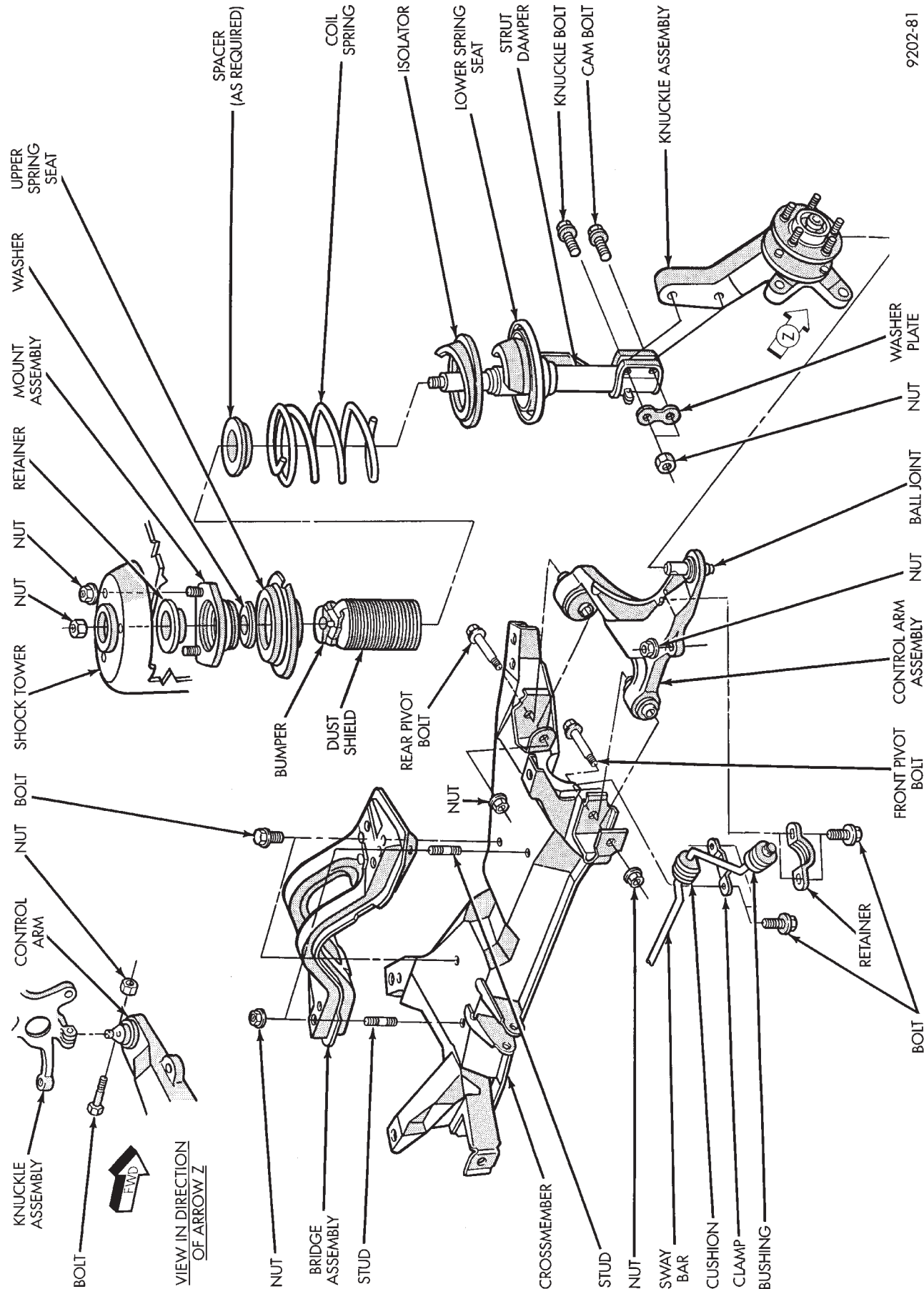
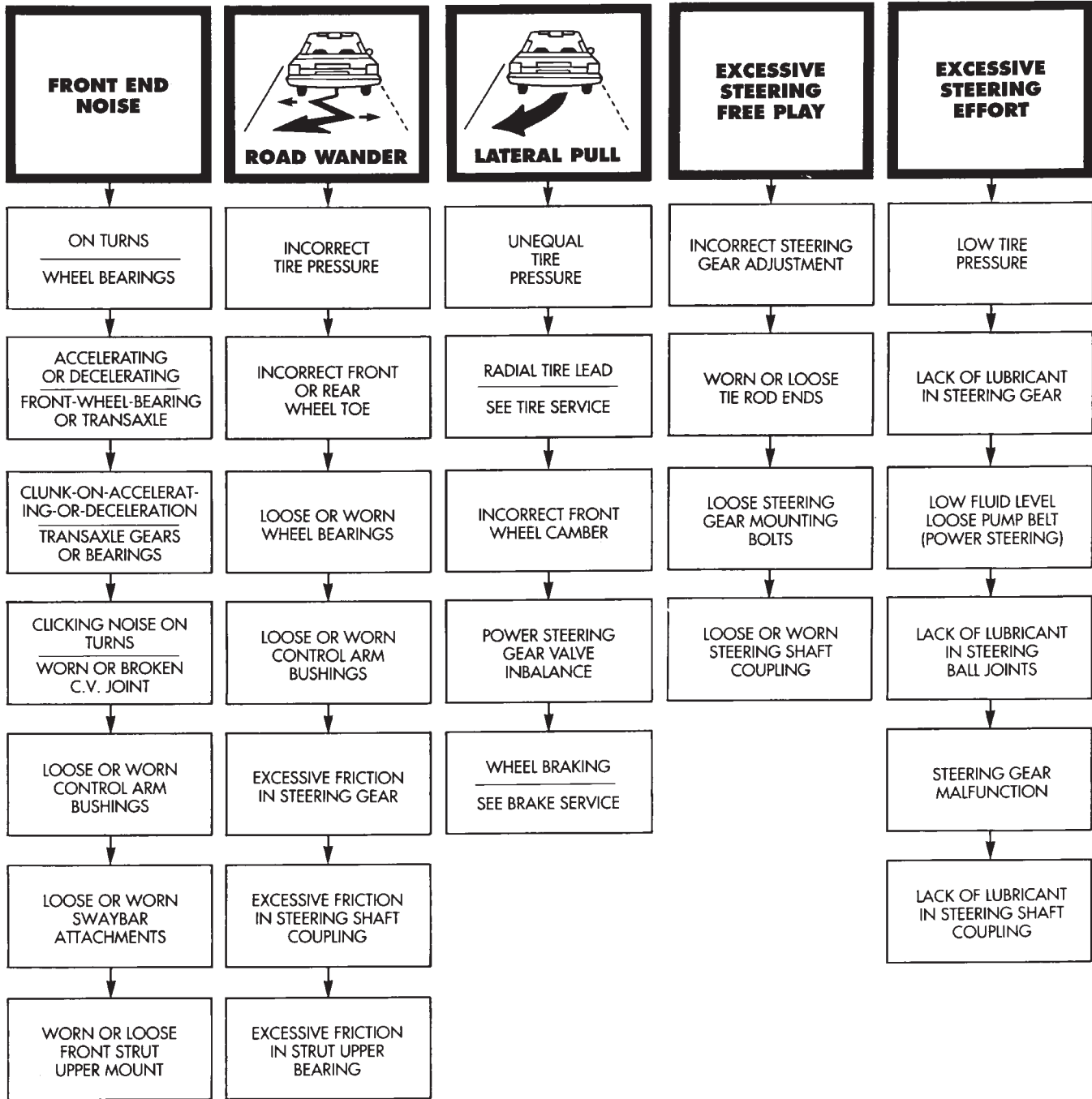

Fig. 3 Front Suspension (A.W.D.) Typical

SUSPENSION/STEERING/DRIVE DIAGNOSIS/FRONT WHEEL DRIVE



FRONT SUSPENSION SERVICE PROCEDURES

INDEX

	page		page
Ball Joints	13	Shock Absorbers (Strut Damper)	10
Hub and Bearing Assembly	20	Strut Damper Assembly	8
Knuckle (Front Suspension)	16	Suspension Coil Springs	10
Lower Control Arm	10	Sway Bar	15
Lower Control Arm Pivot Bushings	11	Wheel Alignment	1

WHEEL ALIGNMENT

Front wheel alignment is the proper adjustment of all the interrelated suspension angles affecting the running and steering of the front wheels of the vehicle.

The method of checking front alignment will vary depending on the type of equipment being used. The instructions furnished by the manufacturer of the equipment should always be followed. With the exception that the wheel alignment specifications recommended by Chrysler Corporation should always be used. The Chrysler Corporation recommended specifications, are listed in Specifications at the back of this service manual section.

There are six basic factors which are the foundation to front wheel alignment. These are vehicle height, caster, camber, toe-in, steering axis inclination and toe-out on turns. Of the six basic factors only camber and toe are mechanically adjustable (Fig. 1).

Do not attempt to modify any suspension or steering components by heating or bending.

Adjustments and checks should be made in the following sequence.

- (a) Camber
- (b) Toe

Camber is the number of degrees the top of the wheel and tire assembly is tilted inboard or outboard from a true vertical line. Inboard tilt is negative camber. Outboard tilt is positive camber (Fig. 1).

Excessive camber is a tire wear factor: negative camber causes wear on the inside of the tire, while positive camber causes wear to the outside.

Toe is measured in degrees or inches and is the distance the front edges of the tires are closer (or farther apart) than the rear edges. See Front Wheel Drive Specifications for **Toe** settings.

PRE-ALIGNMENT

Before any attempt is made to change or correct the wheel alignment factors. The following part inspection and the necessary corrections should be made to those parts which influence the steering of the vehicle.

(1) Check and inflate all tires to recommended pressure. All tires should be the same size and in good condition and have approximately the same wear. Note the type of tread wear which will aid in diagnosing, see Wheels and Tires, Group 22.

(2) Check front wheel and tire assembly for radial runout.

(3) Inspect lower ball joints and all steering linkage for looseness.

(4) Check for broken or sagged front and rear springs.

Front suspension **MUST** only be checked after the vehicle has the following areas inspected and or adjusted. Recommended tire pressures, full tank of fuel, no passenger or luggage compartment load and is on a level floor or alignment rack.

Just prior to each alignment reading. Vehicle should be bounced (rear first, then front) by grasping bumper at center and jouncing each end an equal number of times. Always release bumpers at bottom of down cycle.

CAMBER ADJUSTMENT

(1) Prepare vehicle as described in Pre-Alignment.

(2) Loosen cam and through bolts on each side (See Fig. 1).

(3) Rotate cam bolt to move top of wheel in or out to specified camber.

(4) While holding cam bolt with wrench to keep it from rotating. Tighten cam bolt nuts to 100 N•m (75 ft. lbs.) torque **plus** 1/4 turn beyond specified torque.

9102-4

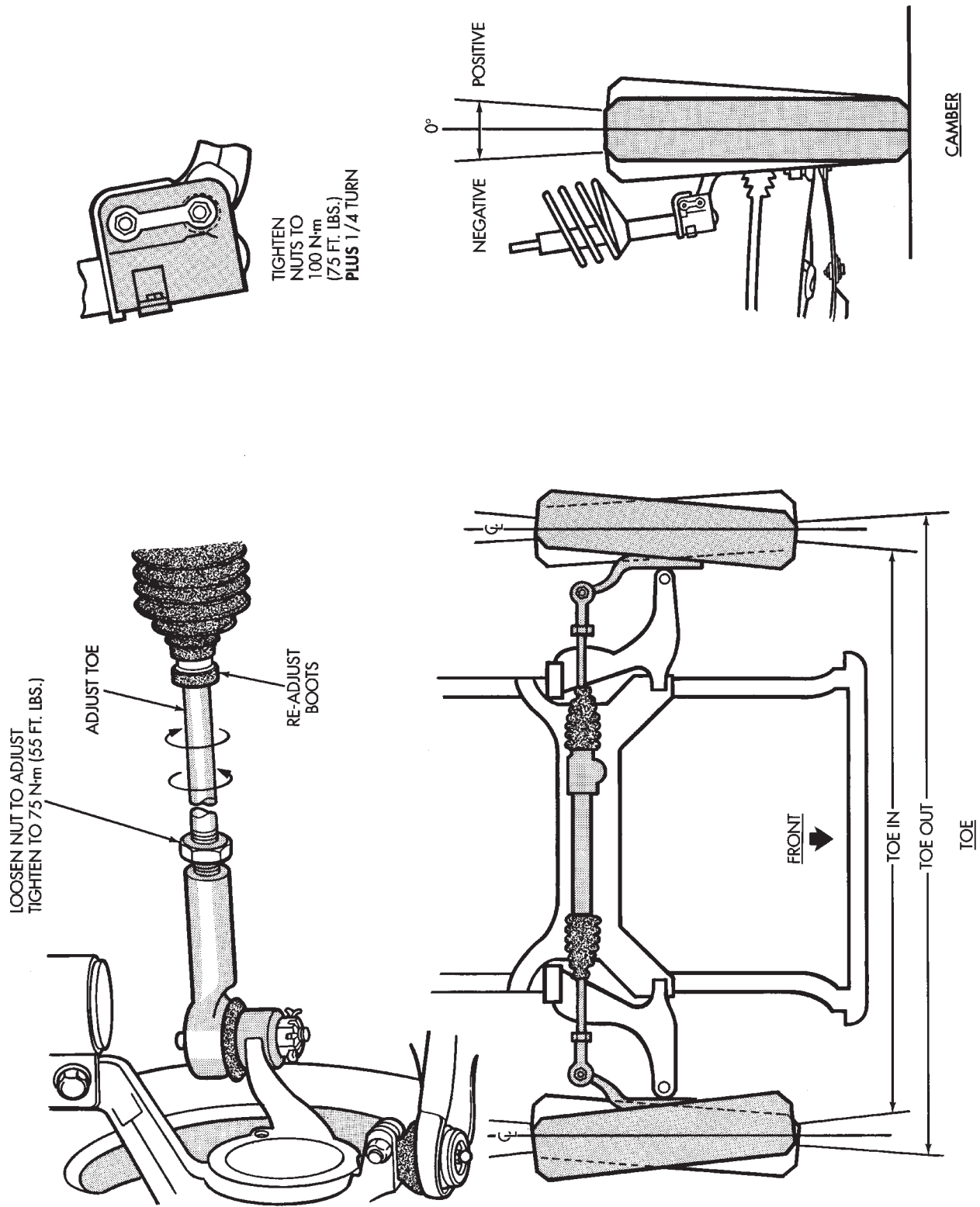

Fig. 1 Alignment Camber/Toe

**TOE ADJUSTMENT**

- (1) Prepare vehicle as described in Pre-Alignment.
- (2) Center steering wheel and hold with steering wheel clamp.
- (3) Loosen tie rod locknuts (Fig. 2). Rotate inner tie rods to align front wheel toe to specifications.

CAUTION: Do not twist inner tie rod to steering gear rubber boots during adjustment.

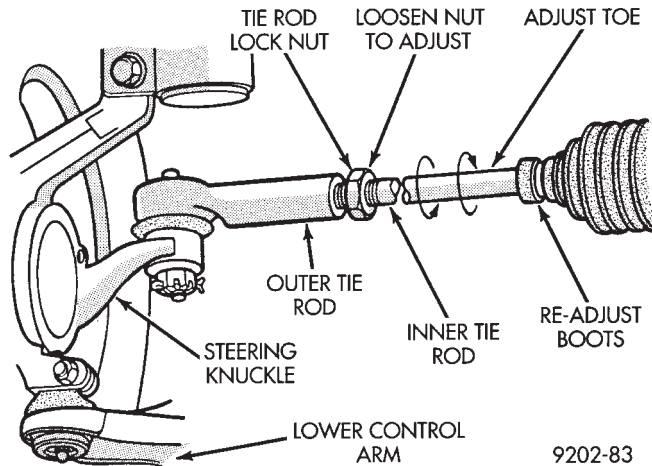

Fig. 2 Front Wheel Toe Adjustment

- (4) Tighten tie rod locknuts to 75 N•m (55 ft. lbs.) torque.
- (5) Adjust steering gear to tie rod boots at tie rod.
- (6) Remove steering wheel clamp.

STRUT DAMPER ASSEMBLY**REMOVAL**

- (1) Loosen front wheel attaching lug nuts.
- (2) Raise vehicle, see Hoisting in Lubrication and Maintenance, Group O.
- (3) Remove front wheel and tire assembly.

Where the service procedure includes reassembly of original strut (shock absorber) to original knuckle. Mark cam adjusting bolt (Fig. 1).

- (4) Remove cam bolt, knuckle bolt and brake hose to damper bracket retaining bolt (Fig. 1).
- (5) Remove strut damper upper mount assembly to shock tower mounting nut and washer assemblies (Fig. 1)

SHOCK ABSORBER INSPECT

Inspect for evidence of fluid leaking from around the strut assembly shaft seal at the upper end of the reservoir. (Actual leakage will be a stream of fluid running down the side and dripping off lower end of unit. **A slight amount of seepage around the strut rod is not unusual and does not affect performance.**)

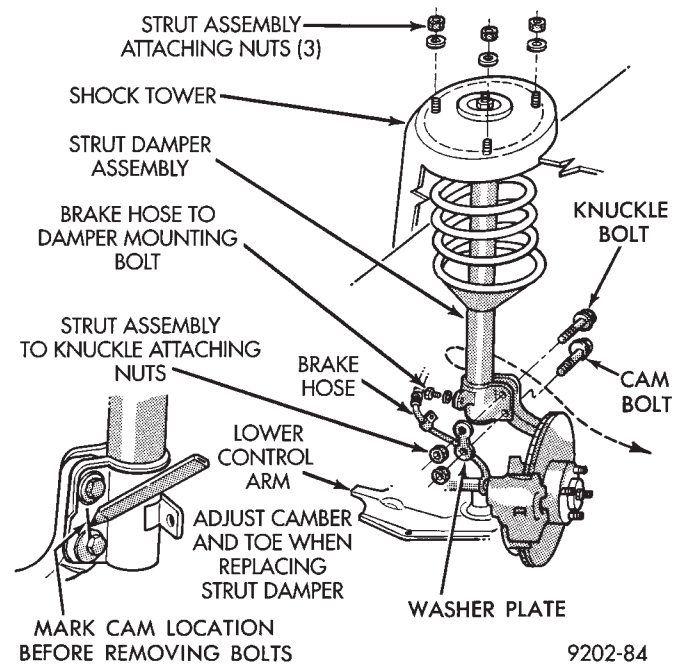

Fig. 1 Strut Damper Removal

INSTALLATION

- (1) Install strut assembly into shock tower. Install the 3 strut assembly to shock tower attaching nut and washer assemblies. Tighten nuts to 27 N•m (20 ft. lbs.) torque.
- (2) Position neck of steering knuckle into strut assembly. Install cam and knuckle bolts through strut assembly and steering knuckle. Install washer plate and nuts (Fig. 1) do not tighten nuts.
- (3) Attach brake hose retainer to damper, tighten screw to 13 N•m (10 ft. lbs.) torque.
- (4) Index cam bolt to original mark (Fig. 2).

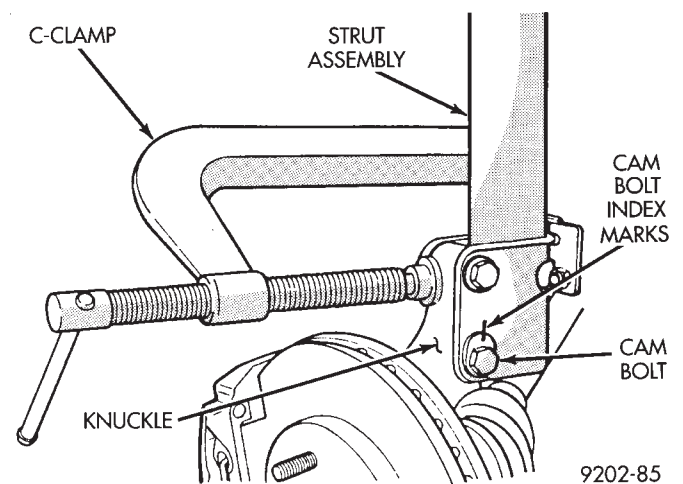

Fig. 2 Strut Assembly Installation

- (5) Place a 4 inch (or larger) C clamp on the strut and knuckle (Fig. 2). Tighten the clamp just enough to eliminate any looseness between the knuckle and the strut, then check alignment of the index marks (Fig. 2). Holding the cam and knuckle bolt so they

cannot rotate, tighten the nuts to 100 N•m (75 ft. lbs.) torque **plus** 1/4 turn. Remove C clamp.

(6) Install wheel and tire assembly. Tighten wheel nuts to 129 N•m (95 ft. lbs.) torque.

DISASSEMBLY (STRUT DAMPER)

(1) Compress front coil spring with Spring Compressor, Special Tool C-4838 (Fig. 3).

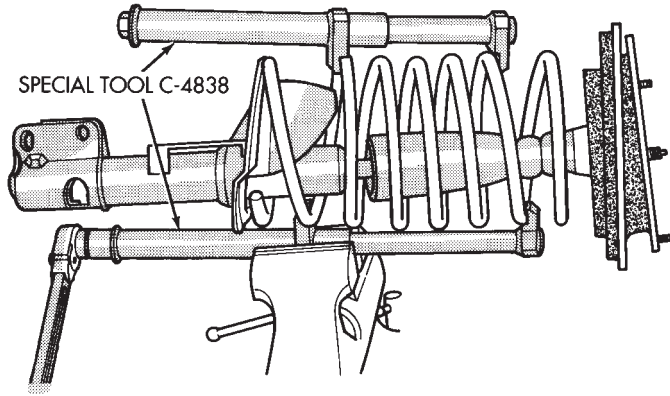

9102-6

Fig. 3 Compressing Coil Spring

(2) Hold end of strut shaft from rotating with wrench, while loosening strut shaft nut. Remove nut from shaft (Fig. 4).

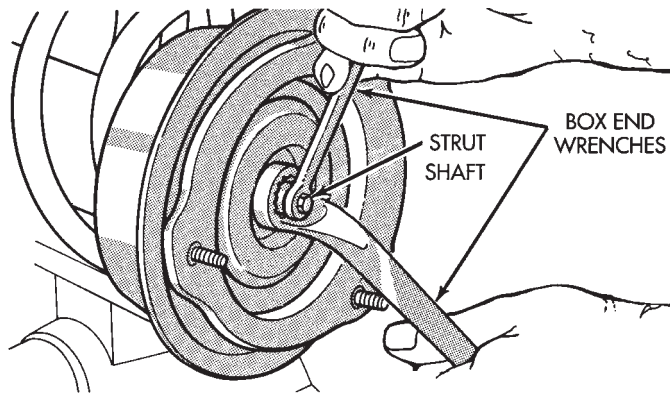

9202-86

Fig. 4 Loosening Strut Assembly Shaft Nut

(3) Remove the upper strut mount from the strut assembly.

(4) Remove coil spring from the strut assembly. **Mark spring for installation back on the same side of the vehicle (Fig. 8).**

CAUTION: see Suspension Coil Springs before releasing coil from Tool C-4838.

(5) Inspect strut damper, mount assembly (Fig. 5) for:

- (a) Severe deterioration of rubber isolator; retainers for cracks and distortion and bond failure of retainers and rubber isolators.
- (b) Bearings for binding.

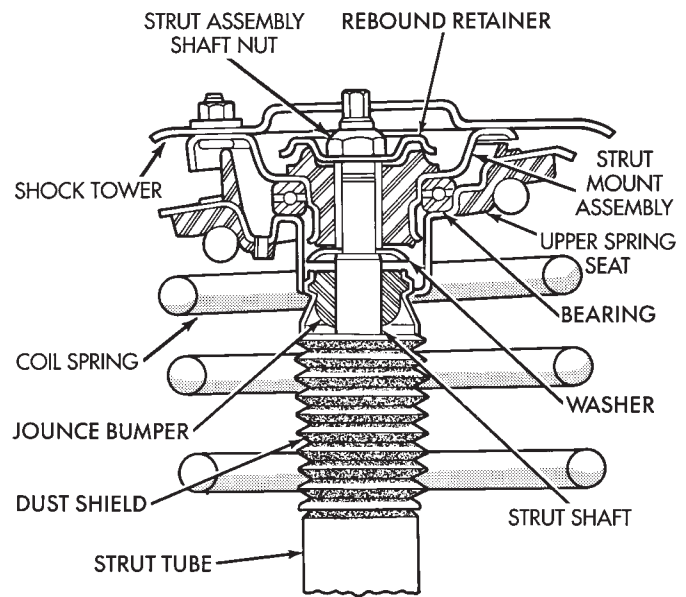

9202-87

Fig. 5 Mount Assembly

(c) Shock Absorber for flat spots over full stroke also see, Shock Absorbers, (strut damper).

ASSEMBLE (STRUT DAMPER)

- (1) Mount the strut assembly in a vertical position.
- (2) Place the compressed spring onto the strut assembly, so the end of the coil is seated in the seat recess in lower spring mount (Fig. 6).

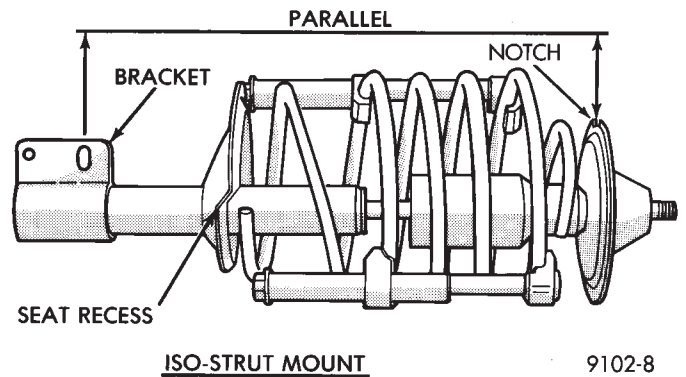

9102-8

Fig. 6 Spring Seat Alignment Notch Position to Bracket

(3) Install the dust shield, isolator (if so equipped) jounce bumper, spacer (as required), and spring seat onto the top of the strut shaft (Fig. 5).

(4) Position top spring seat alignment tab correctly with respect to bottom bracket (Fig. 6).

(5) Install the rebound retainer and shaft nut (Fig. 5).

(6) Tighten the strut shaft nut using, Strut Rod Socket And Holder, Special Tool L-4558. Torque strut shaft nut to 75 N•m (55 ft. lbs.) plus 1/4 turn (Fig. 7).

WARNING: THIS STEP MUST BE DONE BEFORE SPRING COMPRESSOR, SPECIAL TOOL C-4838 IS RELEASED FROM THE COIL SPRING.

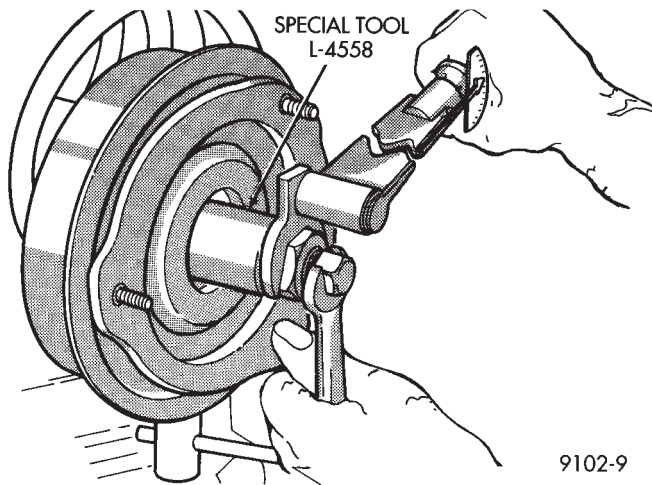

Fig. 7 Tighten Strut Rod Nut with Tool

- (7) Verify coil spring is aligned correctly with respect to bottom bracket (Fig. 6).
- (8) Release Spring Compressor Tool C-4838.

SUSPENSION COIL SPRINGS

Springs are rated separately for each side of vehicle depending on optional equipment and type of service. During service procedures where both springs are removed, mark springs (Chalk, Tape, etc.) (Fig. 8) to ensure installation in original position. If the coils springs require replacement. **Be sure that the springs needing replacement, are replaced with springs meeting the correct load rating for the vehicle and its specific options.**

During service procedures requiring the removal or installation of a coil spring with Spring Compressor, Special Tool C-4838. It is required that five coils be captured within the jaws of the tool (Fig. 8).

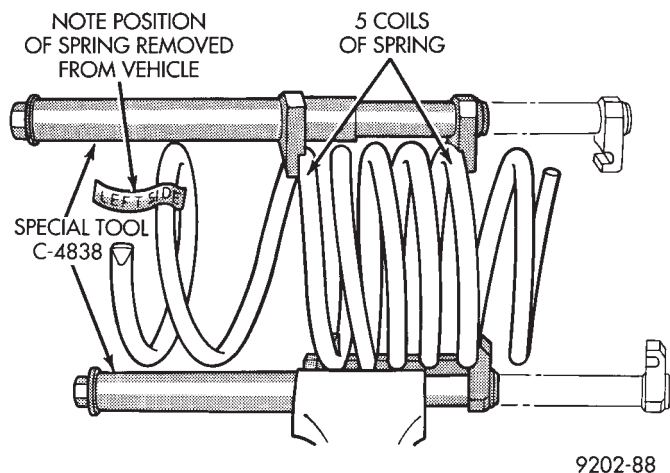

Fig. 8 Identifying Coil Springs

SPRING RETAINER UPPER

Ensure that upper spring retainer is positioned properly, see; step (4), Assemble (Strut Damper).

SPRING SEAT LOWER

During assembly of spring to strut damper, ensure that lower coil end is seated in strut damper spring seat recess refer to (Fig. 6) in assemble (Strut Damper) section.

SHOCK ABSORBERS (Strut Damper)

INSPECTION

Inspect for evidence of fluid leaking from around the strut assembly shaft seal at the upper end of the reservoir. (Actual leakage will be a stream of fluid running down the side and dripping off lower end of unit. A slight amount of seepage around the strut rod is not unusual and does not affect performance.

LOWER CONTROL ARM

The lower control arm if damaged, is serviced only as a complete component. Do not attempt to repair or straighten a broken or bent lower control arm.

The serviceable components of the lower control arm are, the ball joint assembly, and both pivot bushings. The service procedure to replace these components is detailed in the specific component sections of this group.

REMOVAL (ASSEMBLY)

- (1) Raise vehicle. See Hoisting in Lubrication, Group 0 of this service manual.
- (2) Remove the ball joint stud to steering knuckle clamp nut and bolt (Fig. 1).

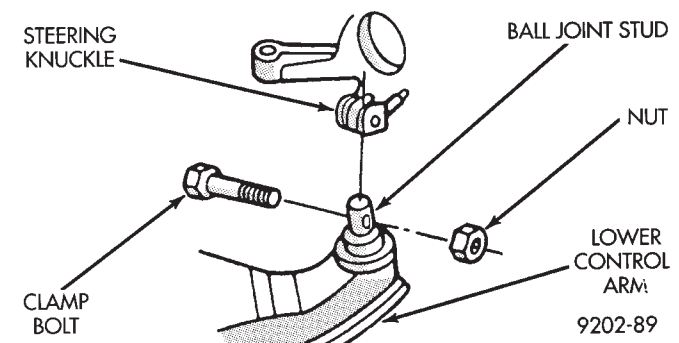

Fig. 1 Control Arm To Steering Knuckle Attachment

- (3) Remove the sway bar to lower control arm retainer on both sides of the vehicle (Fig. 2). Then rotate the sway bar down away from the lower control arms.

(4) Separate the steering knuckle from the ball joint stud (Fig. 1).

(5) Remove the front and rear control arm pivot bushing to crossmember attaching nuts and bolts (Fig. 2). Then remove the lower control arm from the crossmember.

CAUTION: Pulling steering knuckle out from vehicle after releasing from ball joint can separate inner C/V joint. See Driveshafts.

Inspect lower control arm for distortion. Check bushings for severe deterioration.

INSTALLATION (ASSEMBLY)

(1) Position the lower control arm into the crossmember and install front and rear pivot bushing to crossmember attaching bolts and loosely assemble nuts to bolts (Fig. 2).

(2) Install ball joint stud into steering knuckle and install clamp bolt (Fig. 1). Tighten clamp bolt to 136

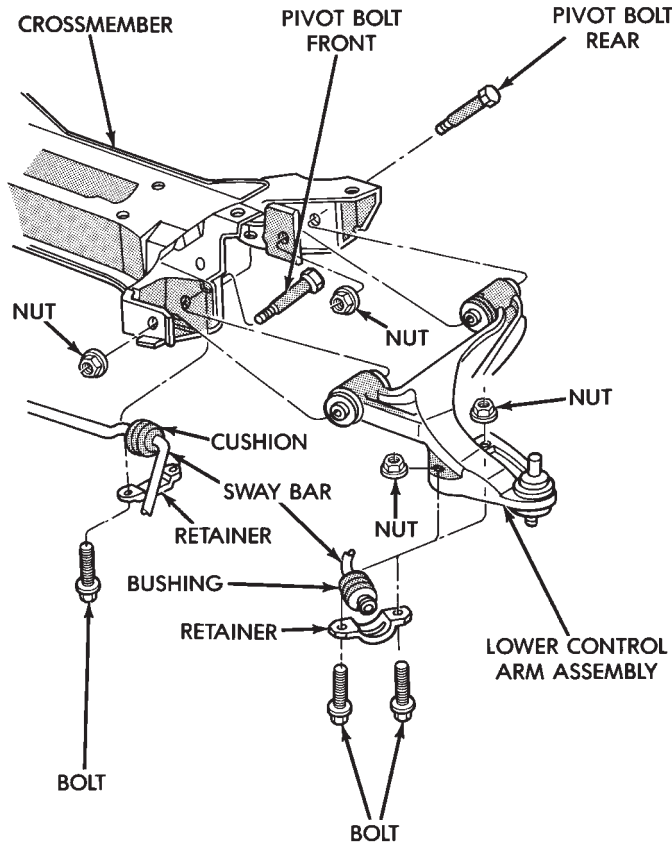

9102-55

Fig. 2 Lower Control Arm Typical

N•m (100 ft. lbs.).

(3) Position sway bar and bushings against the lower control arms. Install sway bar to control arm retainers. Install retainer bolts and tighten nuts to 70 N•m (50 ft. lbs.).

(4) Lower vehicle so the suspension is supporting vehicles weight (control arm at design height). Tighten the lower control arm to crossmember attaching bolts to 169 N•m (125 ft. lbs.) torque.

LOWER CONTROL ARM PIVOT BUSHINGS

When performing the replacement procedure on the lower control arm pivot bushings, the following sequence must be followed. When removing the pivot

bushings from the lower control arm, the large bushing must be removed first then the small bushing. When installing the pivot bushings into the lower control arm, the small bushing must be installed first then the large bushing. This sequence must be used when removal and replacement of bushings is done using Bushing Remover/Installer, Special Tool 6602.

LARGE BUSHING

REMOVE

(1) Position and clamp lower control arm in a vise.
 (2) Assemble the washer, thrust bearing and large bushing disk, Special tool 6602-5 onto the threaded rod from Bushing Remover/Installer, Special Tool 6602 (Fig. 3).

(3) Install the tools assembled in step 2 above into the large bushing of the lower control arm (Fig. 4). Then assemble the remaining Special Tools, Cup 6602-2, thrust bearing, washer and nut onto the threaded rod (Fig. 4) from Bushing Remover/Installer, Special Tool 6602.

(4) Hold the long nut stationary. Using a deep socket turn the long threaded rod until the large pivot bushing is pushed out of the lower control arm.

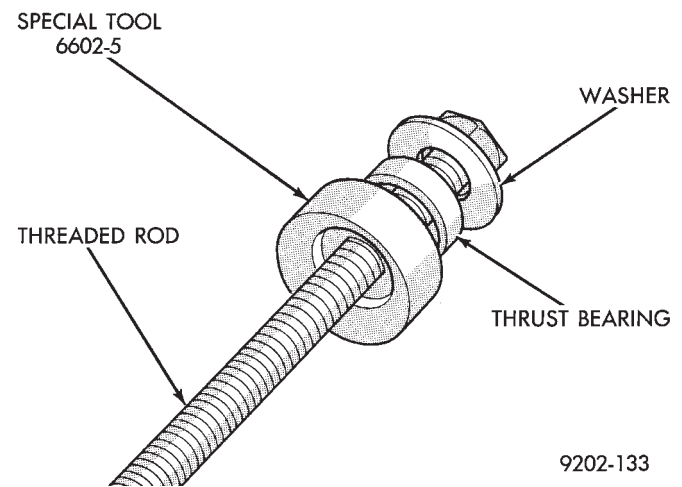

Fig. 3 Bushing Removal Tools

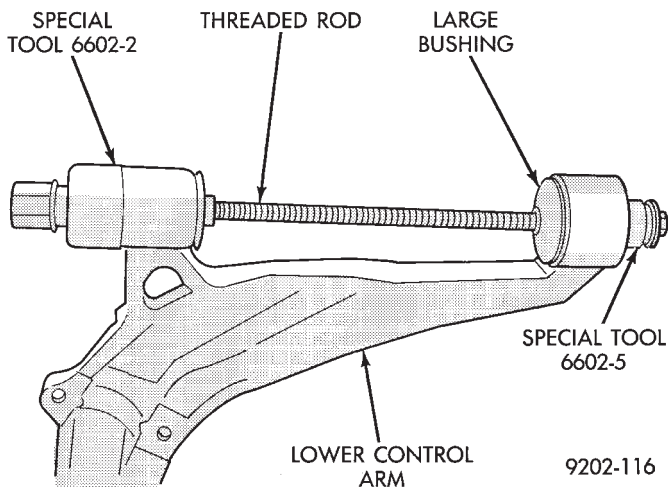

Fig. 4 Tool Assembled For Bushing Removal

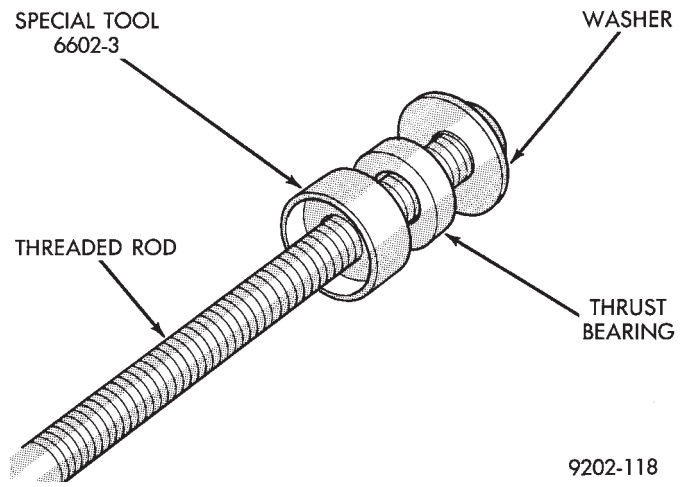

Fig. 5 Bushing Removal Tools

SMALL BUSHING

REMOVE

(1) Remove the special tools from the lower control arm that were used for the removal of the large pivot bushing.

(2) Remove the large Bushing Disc, Special Tool 6602-2 from the threaded rod. Leave the thrust bearing and washer on the threaded rod. Install the small Bushing Disc, Special Tool 6602-3 on the threaded rod and against thrust bearing (Fig. 5).

(3) Install the tools assembled in step 2 above through small lower control arm bushing and hole in lower control arm where large bushing was removed from (Fig. 6). Assemble the Cup, Special Tool 6602-2 thrust bearing, washer and long nut onto the threaded rod of Special Tool 6602. (Fig. 6). Cup, Special Tool 6602-2 is to be installed on threaded rod with cup facing out and undercut in large bushing hole of lower control arm (Fig. 6).

(4) Hold the threaded rod stationary and turn the long nut until the small pivot bushing is pulled out of the lower control arm.

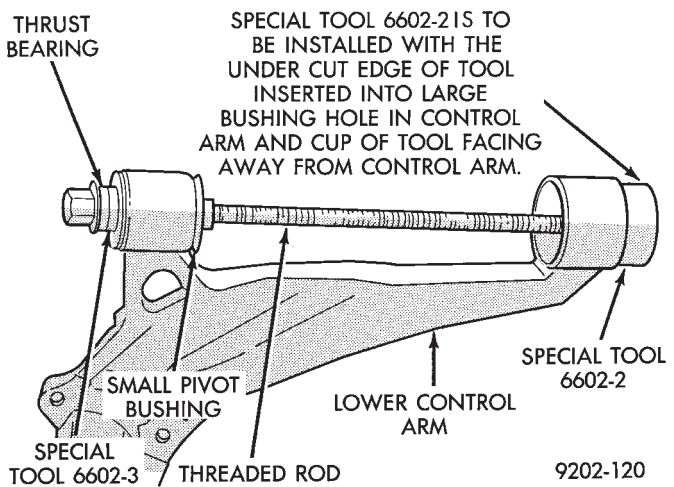

Fig. 6 Tool Assembled For Bushing Removal

SMALL BUSHING

INSTALL

(1) Remove the special tools from the lower control arm that were used for the removal of the small pivot bushing.

(2) On the threaded rod from Remover/Installer, Special Tool 6602 assemble the following pieces. Washer, thrust bearing, small bushing disc Special Tool 6602-3, small lower control arm pivot bushing and small bushing sizer, Special Tool 6602 (Fig. 7).

(3) Install the pieces assembled in step 2 through the small and large pivot bushing holes in the lower control arm. At the large pivot bushing hole in the lower control arm, assemble Cup, Special Tool 6602-2, thrust bearing, washer and nut (Fig. 8). Lubricate the installer cone and new bushing using Mopar®, Silicone Sray Lube or equivalent.

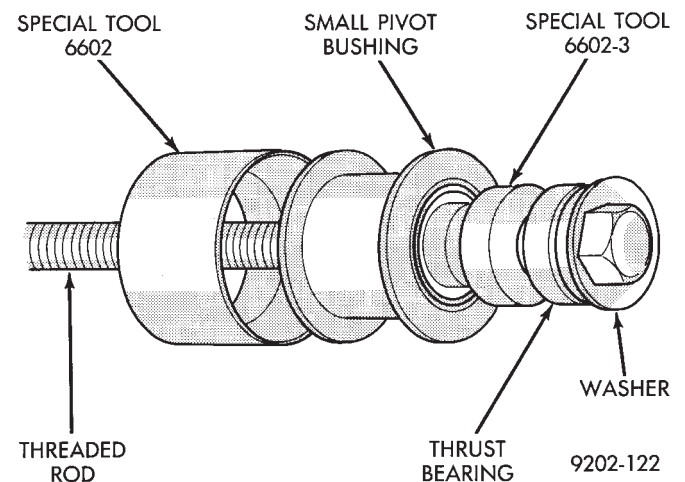

Fig. 7 Bushing Installing Tools Assembled

(4) Hold the threaded rod stationary and turn the long nut until the small pivot bushing is fully installed into the lower control arm. Be sure that the flanges of the bushing are fully expanded around the control arm bushing holes (Fig. 13).

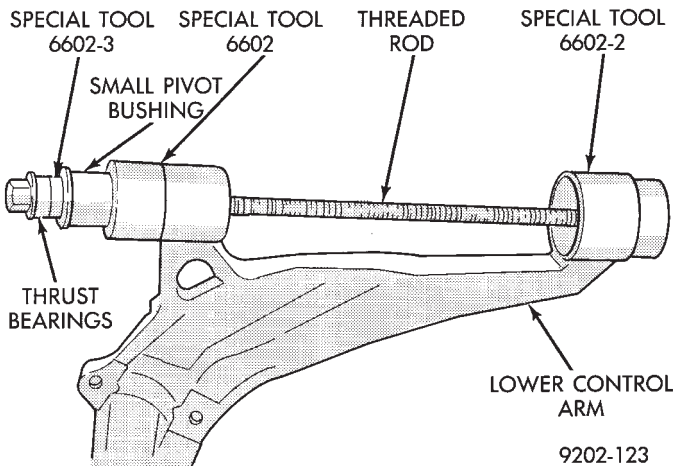

Fig. 8 Bushing And Tool Position For Installation In Control Arm

LARGE BUSHING

INSTALL

(1) Remove the special tools from the lower control arm that were used for installing the small pivot bushing.

(2) On the threaded rod from Remover/Installer, Special Tool 6602 assemble the following pieces. Washer, thrust

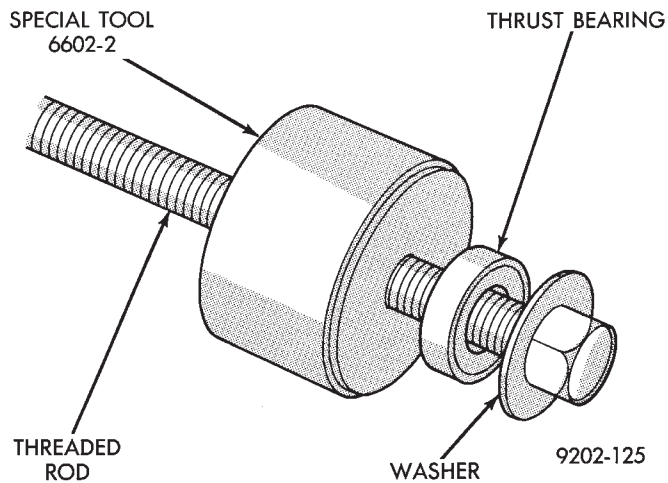

Fig. 9 Bushing Installer Tools

bearing, Cup Special Tool 6602-2 (Fig. 9).

(3) Install the pieces assembled in step 2 through the hole in the small pivot bushing and the large pivot bushing hole in the lower control arm. At the large pivot bushing hole in the lower control arm assemble the following special tool pieces. Large Bushing Sizer, Special Tool 6602-4, large lower control arm pivot bushing, large bushing disc Special Tool 6602-5, thrust bearing, washer and nut (Fig. 10). Lubricate the installer cone and new bushing using Mopar® Silicone Spray Lube or equivalent.

(4) Hold the threaded rod stationary and turn the long nut until the bushing is fully installed into the control arm. Be sure that the flanges of the bushing are fully expanded around the control arm bushing holes.

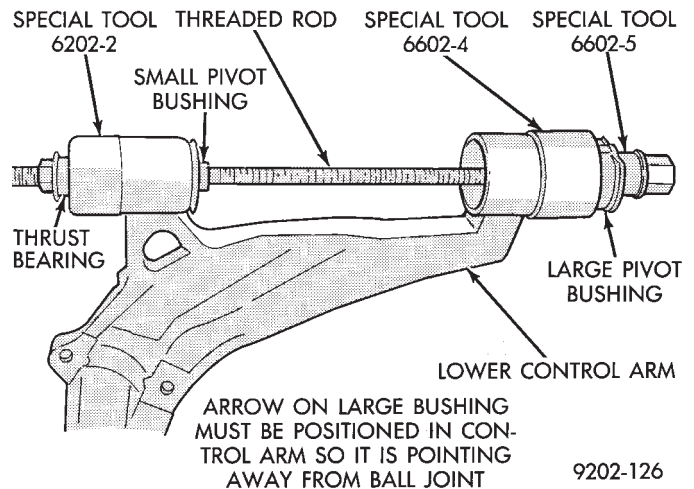

Fig. 10 Bushing And Tool Position For Installation In Control Arm

(5) If the position of the large lower control arm pivot bushing (Fig. 11) moved during bushing installation. Install a nut and bolt through the bushing sleeve and tighten it down (Fig. 11). Using a wrench rotate the bolt until the bushing is in the correct position (Fig. 10)

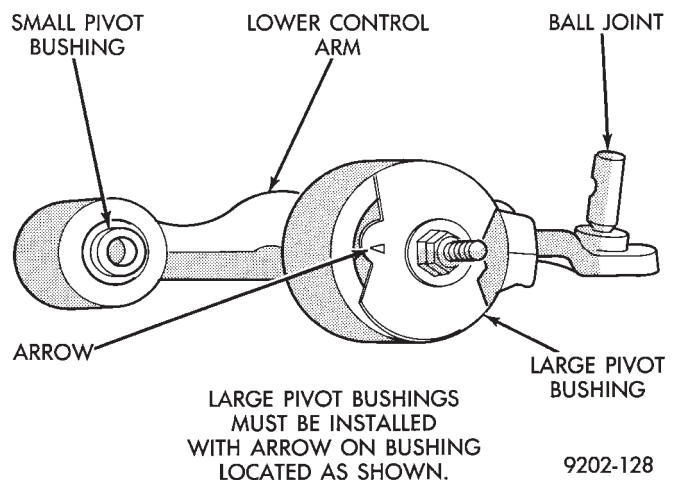

Fig. 11 Positioning Control Arm Bushing

BALL JOINTS

The lower front suspension ball joints operate with no free play. See Inspection Ball Joint Wear to determine if the ball joint is worn and requires replacement.

The ball joints are replaceable as an assembly, do not attempt any type of repair on the ball joint assembly. The replacement procedure for the ball joint assembly is detailed in this section.

The ball joint housing is a pressed fit into the lower control arm with the joint stud retained in the steering knuckle by a (clamp) bolt.

INSPECTION BALL JOINT WEAR

With the weight of the vehicle resting on the road wheels. Grasp the grease fitting as shown in (Fig. 1) and with no mechanical assistance or added force attempt to move the grease fitting.



If the ball joint is worn the grease fitting will move easily. If movement is noted, replacement of the ball joint is recommended.

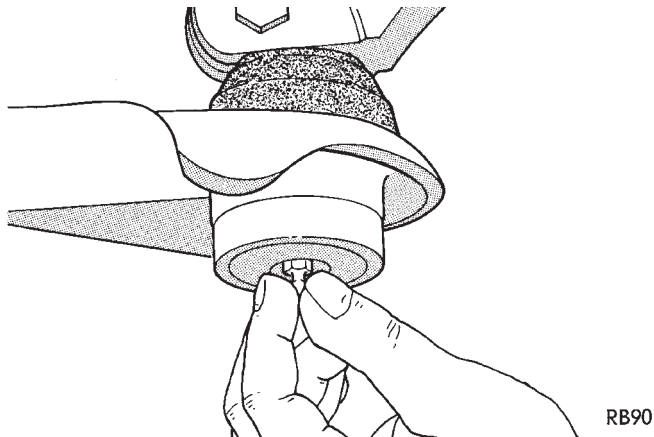

Fig. 1 Checking Ball Joint Wear

RB90

BALL JOINT REMOVAL

- (1) Pry off seal.
- (2) Position Receiving Cup Tool C-4699-2 to support lower control arm while receiving ball joint assembly (Fig. 2).
- (3) Install Remover/Installer Special Tool C-4699-1 (Fig. 2) over ball joint stud and against the ball joint upper housing.
- (4) Press down against the ball joint upper housing, to remove ball joint assembly from lower control arm.

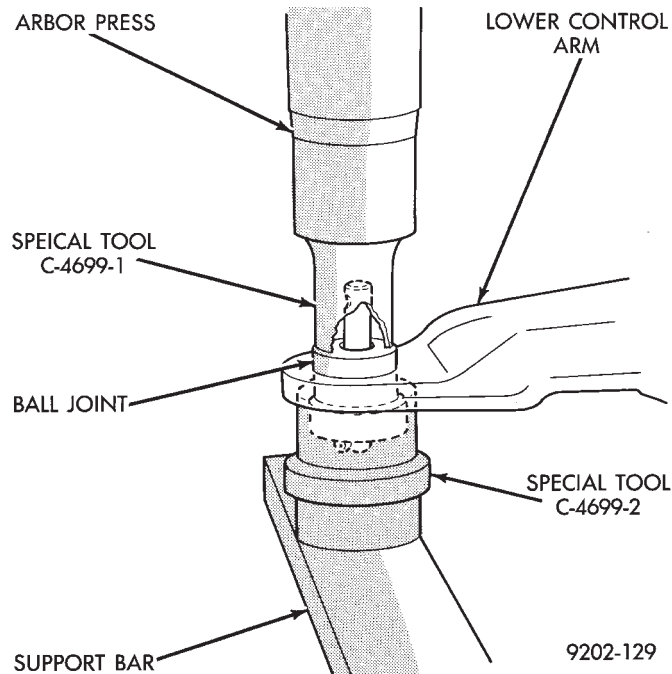

Fig. 2 Removing Ball Joint

9202-129

BALL JOINT INSTALLATION

- (1) By hand, position ball joint assembly into the ball joint bore of the lower control arm. Be sure the ball joint assembly is not cocked in the bore of the control arm, this will cause binding of the ball assembly.
- (2) Position assembly in press with Installer Tool C-4699-2 supporting control arm (Fig. 3).

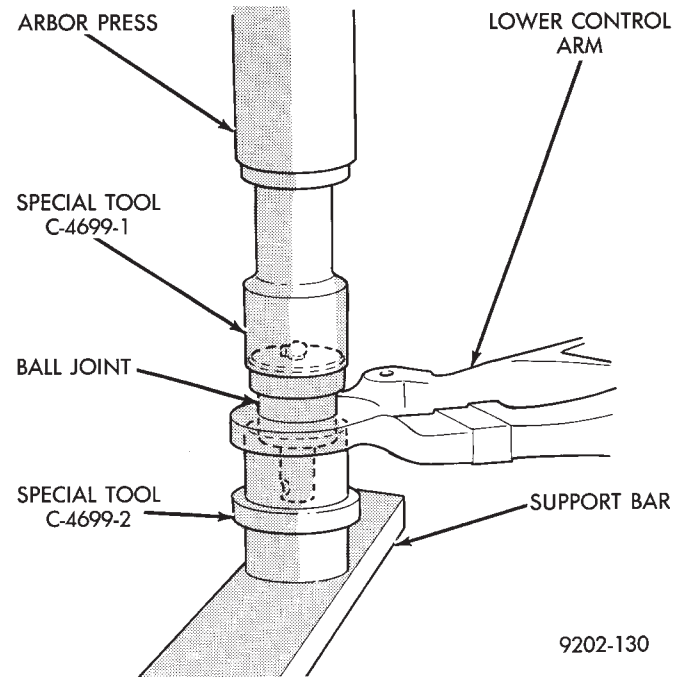

Fig. 3 Installing Ball Joint

9202-130

- (3) Install the Remover/Installer, Special Tool C-4699-1 over the ball joint stud and down on the lower control arm assembly (Fig. 3).
- (4) Carefully align all pieces. Using an arbor press apply pressure against the ball joint assembly, until ball joint is fully seated against bottom surface of control arm. Do not apply excessive pressure against the control arm.

BALL JOINT SEAL INSTALLATION

- (1) Support ball joint housing with Installer, Special Tool C-4699-1 (Fig. 4). Position new seal over ball joint stud and against ball joint housing.
- (2) With 1-1/2 inch socket, press seal onto ball joint housing until it is squarely seated against top surface of control arm as shown in (Fig. 4).

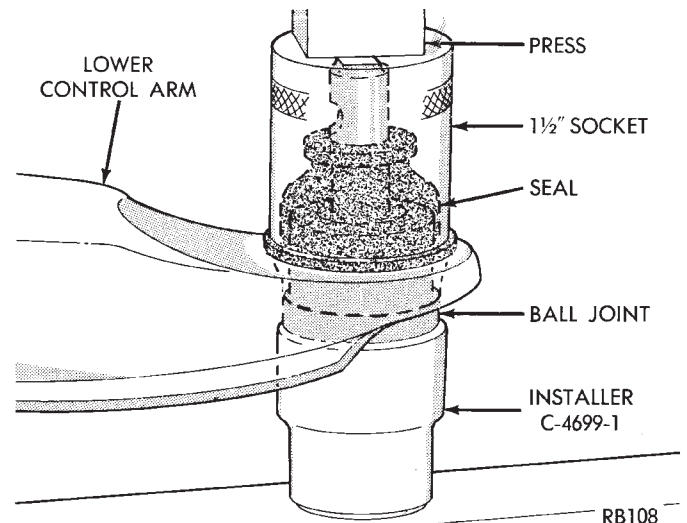

Fig. 4 Installing Ball Joint Seal

RB108

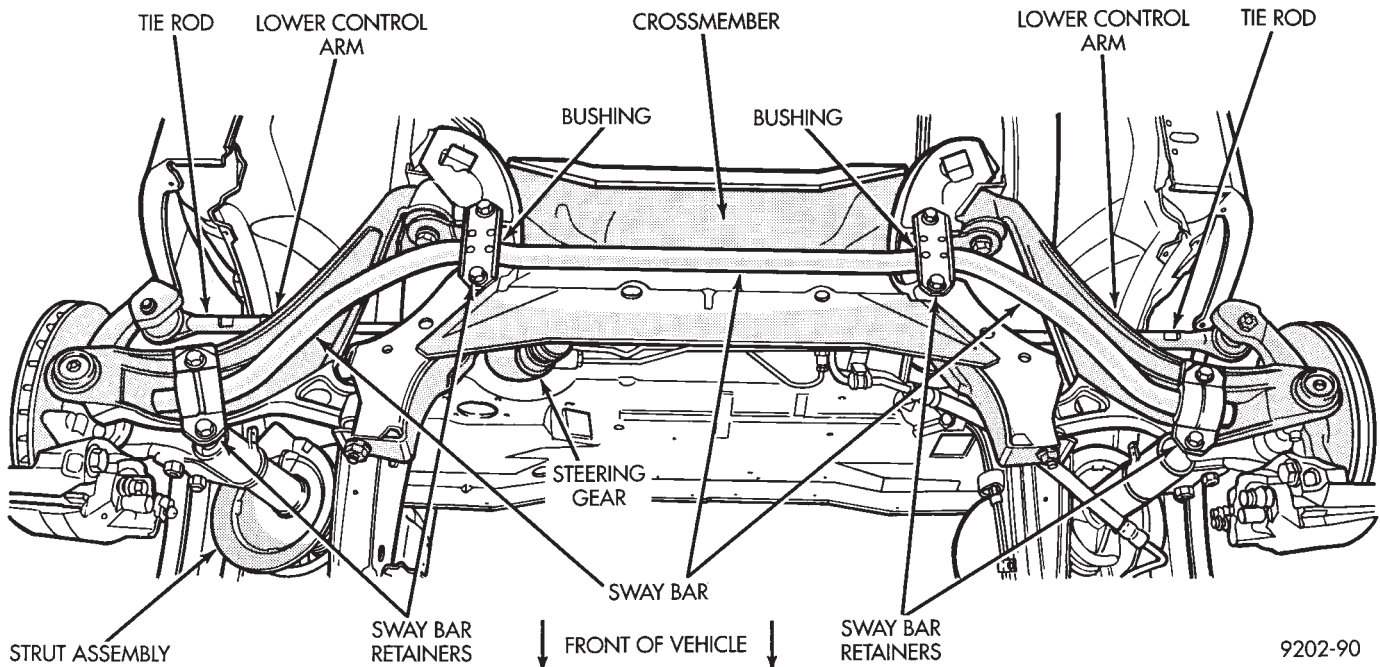

Fig. 1 Front Sway Bar

SWAY BAR

The sway bar interconnects the front lower control arms of the vehicle and attaches to the crossmember (Fig. 1).

Jounce and rebound movements affecting one wheel are partially transmitted to the opposite wheel to stabilize body roll.

Attachment to the crossmember, and front lower control arms is through rubber-isolated bushings. All parts are serviceable, and the sway bar to crossmember bushings are split for easy removal and installation. The split in the sway bar to crossmember bushing should be positioned toward the front of the vehicle.

REMOVAL

- (1) Raise and support the vehicle. See Hoisting in Lubrication and Maintenance, Group 0.
- (2) Remove the nuts, bolts, and sway bar retainers at the front lower control arms (Fig. 1).
- (3) Remove the bolts at sway bar crossmember clamps, and remove clamps and sway bar from vehicle (Fig. 1).

INSPECTION

Inspect for broken or distorted clamps, retainers, and bushings. If bushing replacement is required, the inner bushing can be removed by opening the split. The outer bushing must be cut or hammered off the bar. If replaced, the outer bushings should be forced on so that approximately 1/2 inch of the bar protrudes. The sway bar to crossmember bushings, should be positioned when installed, so the void on the bushing is positioned toward the rear of the vehicle (Fig. 2). Note that the control arm retainers are symmetric and bend slightly upon installation.

INSTALLATION

- (1) If inspection of the sway bar assembly, determined that sway bar to lower control arm bushings require replacement. Install the new bushings, by forcing them onto sway bar using a rotating motion. Bushings should be installed on sway bar so that sway bar extends 1/2 inch out past the end of the bushing.
- (2) If required position sway bar to crossmember bushings on sway bar with external rib up and void in the bushing facing the rear of vehicle (Fig. 2). Lift the bar assembly into the crossmember, and install the lower clamps and bolts. The center offset in the sway bar should be oriented toward the front of the vehicle (Fig. 1)

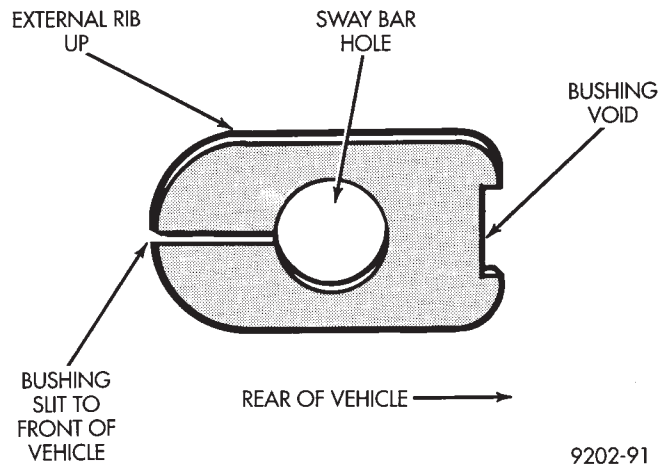

Fig. 2 Sway Bar To Crossmember Bushing Position

9202-90

9202-91

(3) Position bushing retainers on lower control arms, insert bolts, and install nuts. The bolts should be installed so that the threaded portion of the bolt is up, with the nut is against the lower control arm not the bushing retainer (Fig. 1).

(4) With lower control arms raised to design height, tighten all retainer attaching bolts to 70 N•m (50 ft. lbs.) torque.

(5) Lower vehicle.

KNUCKLE (FRONT SUSPENSION)

The front suspension knuckle (Fig. 1) provides for steering control of the vehicle. Supports the brake caliper and absorbs the loads exerted during vehicle braking. It also supports the front (driving) hub and bearing and stub axle assembly.

The front suspension knuckle also provides the ability to align the front wheels of the vehicle. This is done by allowing for front wheel camber adjustment and the ability for front tire Toe adjustments

The front suspension knuckle is not a serviceable component. Do not attempt to straighten or repair the front suspension knuckle in any way.

Service repair or replacement of the front (drive) hub and bearing, can be done with the front suspension knuckle remaining on the vehicle.

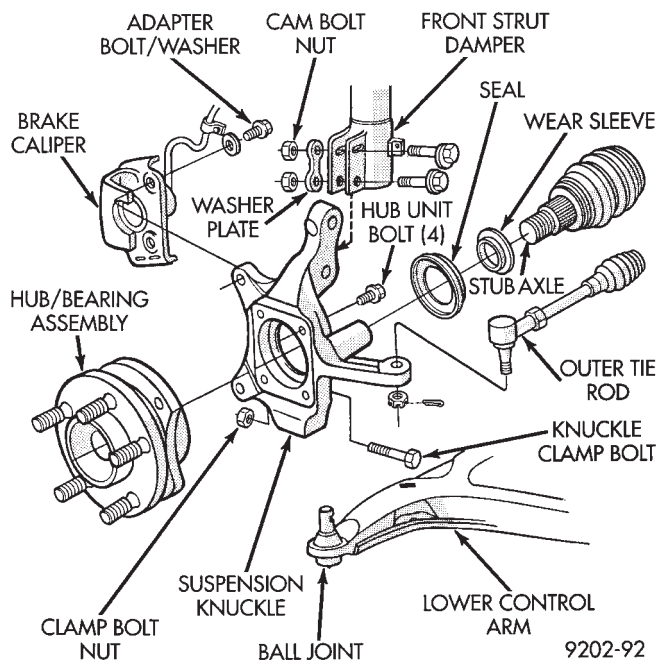

Fig. 1 Front Knuckle Assembly (Typical)

REMOVAL

(1) Remove the cotter pin, hub nut lock and spring washer from the front axle (Fig. 2).

(2) Loosen hub nut while the vehicle is on the floor with the brakes applied (Fig. 3). **The hub and drive-shaft are splined together through the knuckle (bearing) and retained by the hub nut.**

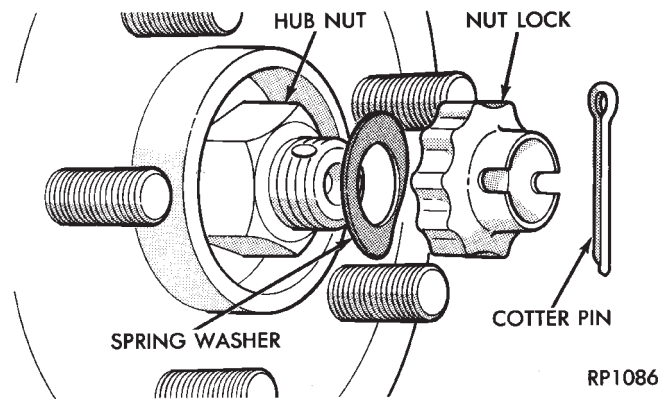

Fig. 2 Remove Cotter Pin, Hub Nut Lock, & Spring Washer

(3) Raise and support the vehicle. See Hoisting in Lubrication and Maintenance, Group 0.

(4) Remove the wheel lug nuts, front tire and wheel assembly and hub nut and washer.

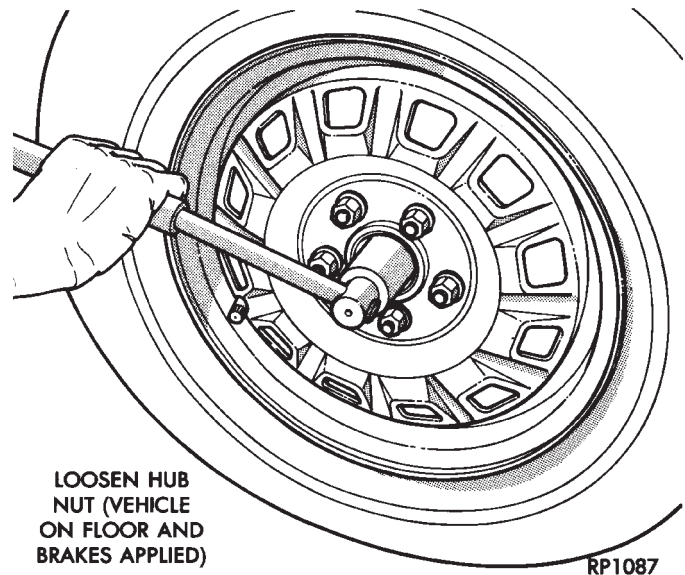

Fig. 3 Loosen Hub Nut

(5) Remove the brake caliper adapter to steering knuckle attaching bolts and washers (Fig. 1). Remove the brake caliper and adapter from the steering knuckle and braking disc. Support brake caliper/adapter assembly using a wire hook and not by hydraulic hose (Fig. 4).

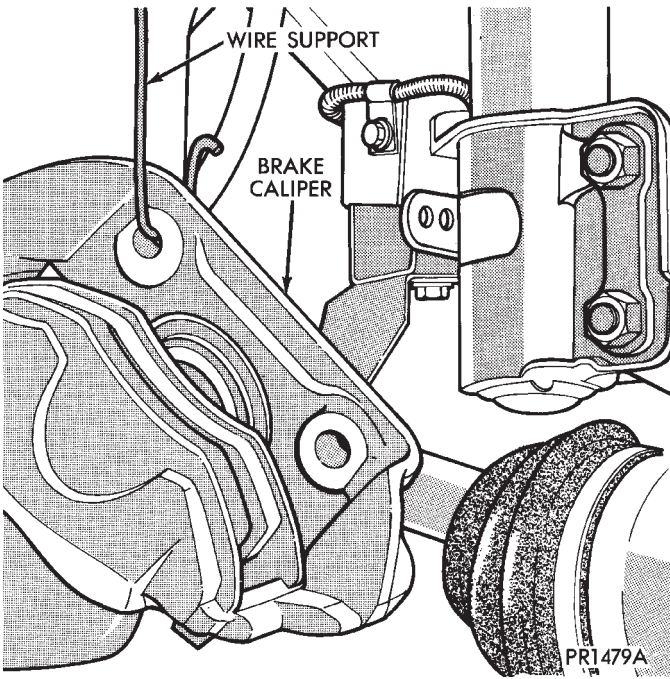

Fig. 4 Supporting Brake Caliper

(6) Remove the braking disc from the front hub/bearing assembly (Fig. 5).

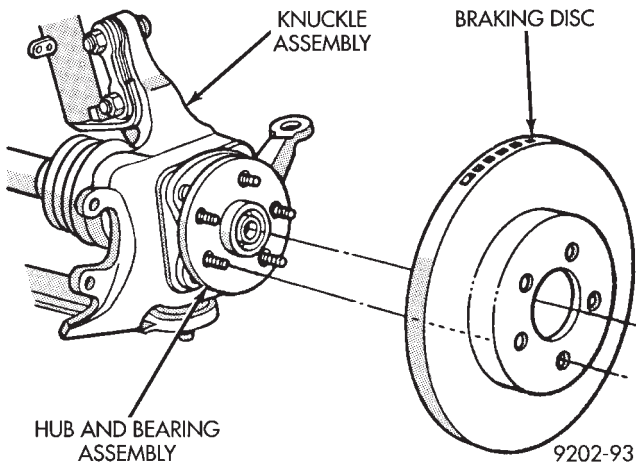

Fig. 5 Remove or Install Braking Disc

(7) Remove the cotter pin and nut from the tie rod end. Remove the tie rod end from the steering knuckle arm using Puller, Special Tool C-3894-A (Fig. 6).

(8) Remove the clamp nut and bolt (Fig. 7) securing the ball joint stud into the steering knuckle.

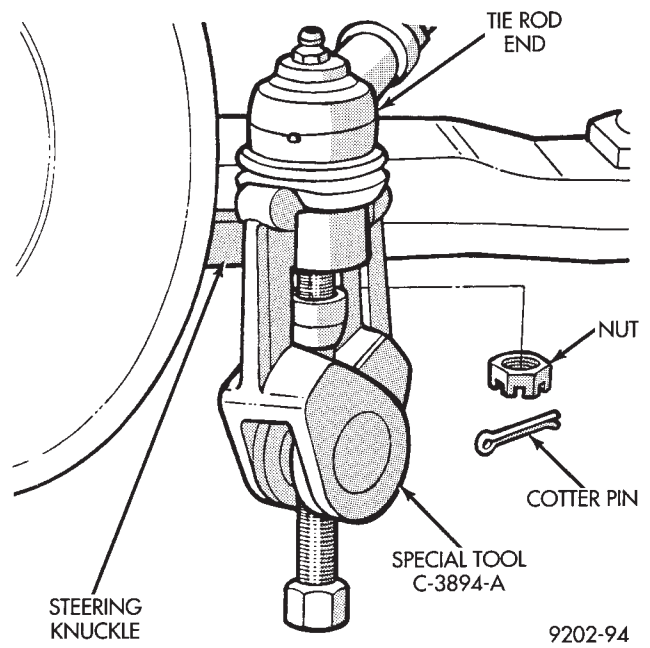

Fig. 6 Disconnect Tie Rod End

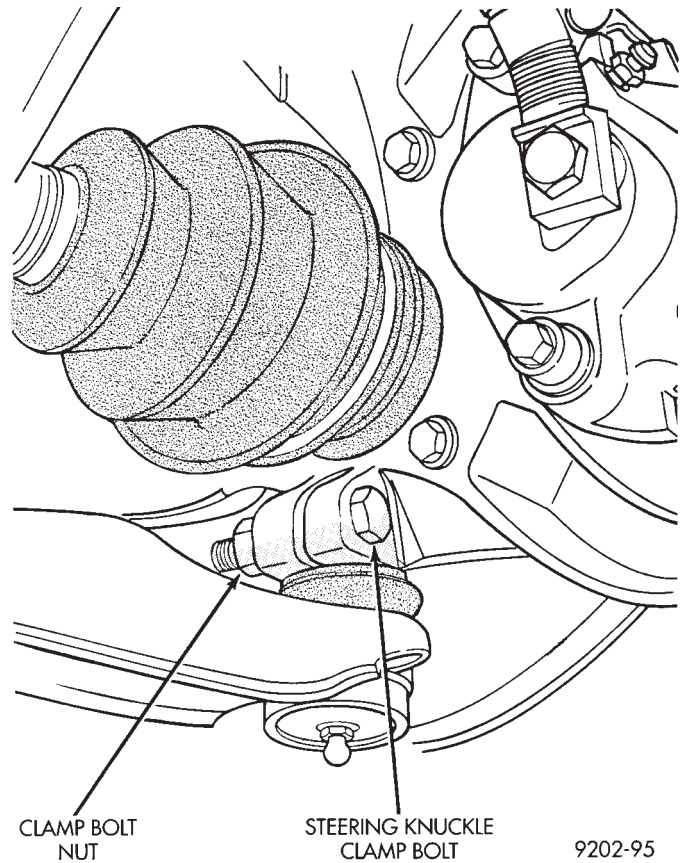

Fig. 7 Remove or Install Steering Knuckle Clamp Bolt

(9) Separate ball joint stud from knuckle assembly by prying down on lower control arm. Pull knuckle assembly out and away from driveshaft (Fig. 8).

Care must be taken not to separate the inner C/V joint during this operation. Do not allow driveshaft to hang by inner C/V joint, driveshaft must be supported.

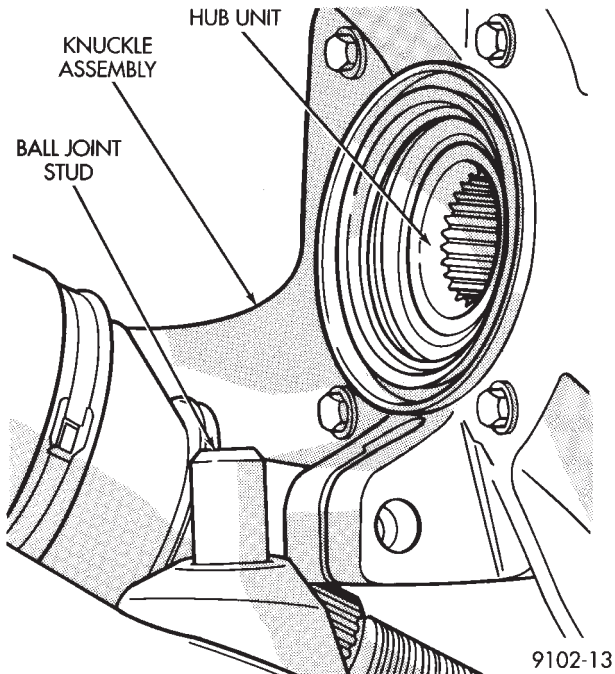

Fig. 8 Separate Ball Joint Stud from Knuckle Assembly

(10) Remove the steering knuckle to strut damper attaching bolt and cam bolt (Fig. 9). **Note the location of the cam bolt, it must be installed in the same location when steering knuckle is installed back on strut damper.**

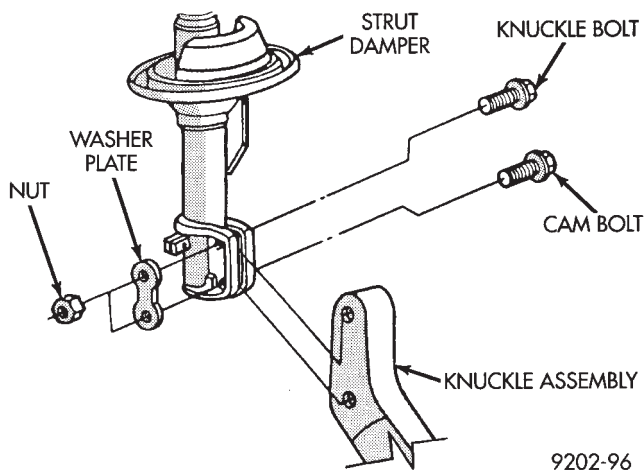

Fig. 9 Remove Or Install Steering Knuckle

(11) Mount the steering knuckle in a vise and remove the 4 bolts on back of steering knuckle, attaching the hub and bearing assembly. Remove the hub and bearing assembly from the steering knuckle (Fig. 10).

Remove outer C/V joint seal from the steering knuckle.

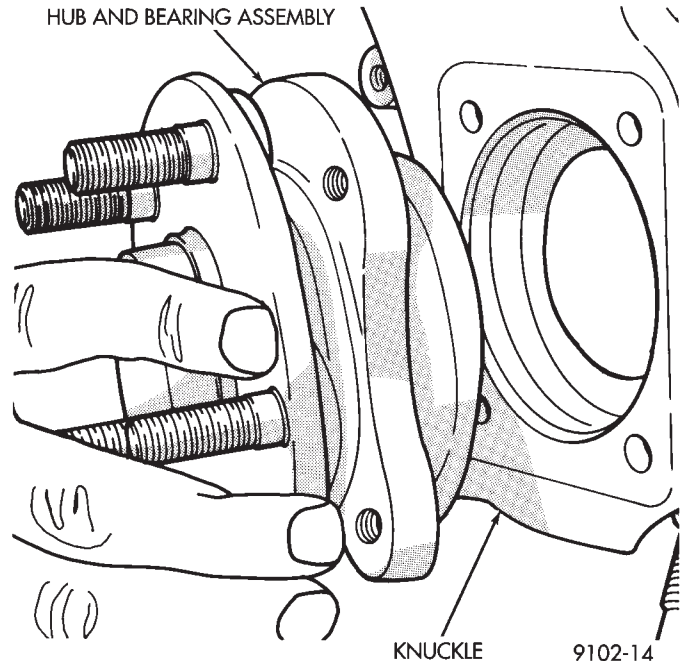

Fig. 10 Remove Or Install Hub and Bearing Assembly

INSTALL

CAUTION: Knuckle and bearing mounting surfaces must be smooth and completely free of foreign material or nicks.

(1) Install the hub and bearing assembly into the steering knuckle (Fig. 10). Install the 4 hub and bearing assembly to steering knuckle attaching bolts and torque in a criss-cross pattern to 65 N•m (45 ft. lbs.)

(2) Position new seal in recess on back of the steering knuckle. Assemble Installer, Special Tool C-4698 and install seal into steering knuckle until it is fully seated into recess (Fig. 11). Inspect the wear sleeve on the C/V joint housing and replace if required.

(3) Install the steering knuckle back on the strut damper (Fig. 9). Install the strut damper to steering knuckle attaching bolt, cam bolt, washer plate and nuts. Torque bolts to 100 N•m (75 ft.lbs.) plus 1/4 turn. **Be sure the cam bolt is installed in same location it was removed from.**

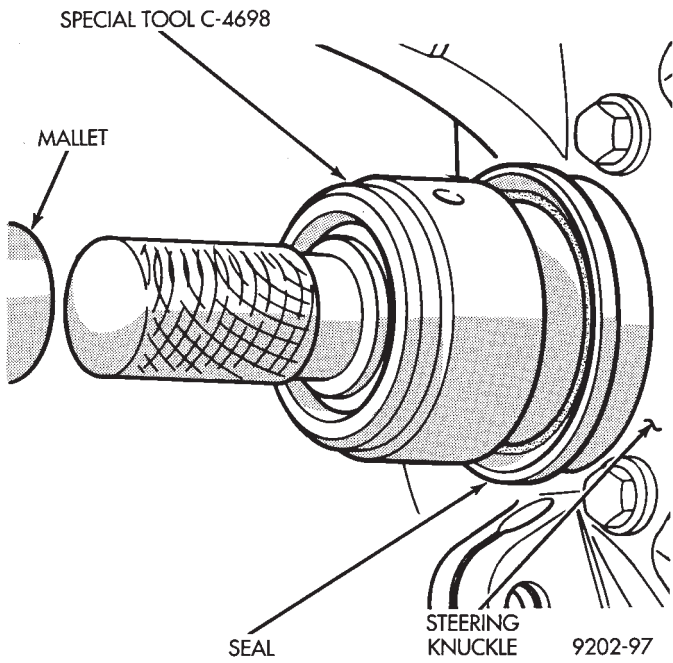

Fig. 11 Seal Installation In Steering Knuckle

(4) Lubricate the FULL circumference of the seal (and wear sleeve) with Mopar® Multi-Purpose Lubricant, or equivalent (Fig. 12).

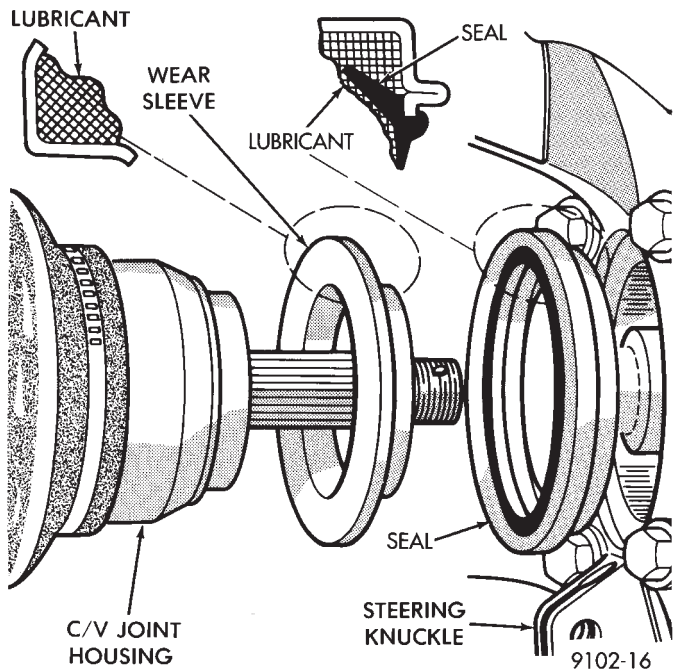

Fig. 12 Seal and Wear Sleeve Lubrication

(5) Slide the drive shaft back into the hub and bearing assembly and install the steering knuckle onto the ball joint stud (Fig. 13).

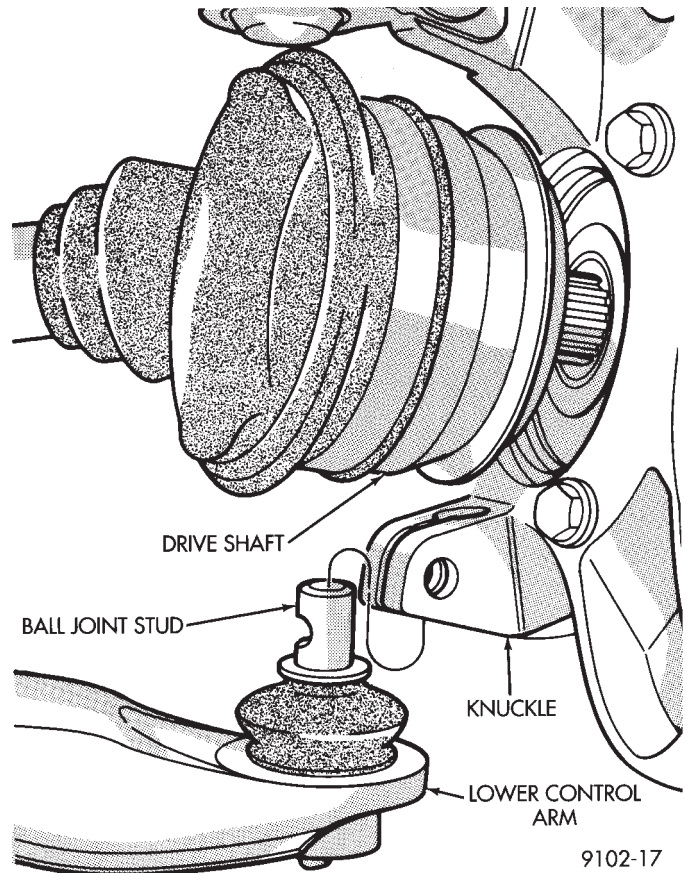

Fig. 13 Installing Knuckle Assembly

(6) Install the original (or equivalent) steering knuckle to ball joint stud, clamp bolt and nut (Fig. 14). Torque the clamp bolt to 136 N•m (100 ft. lbs.).

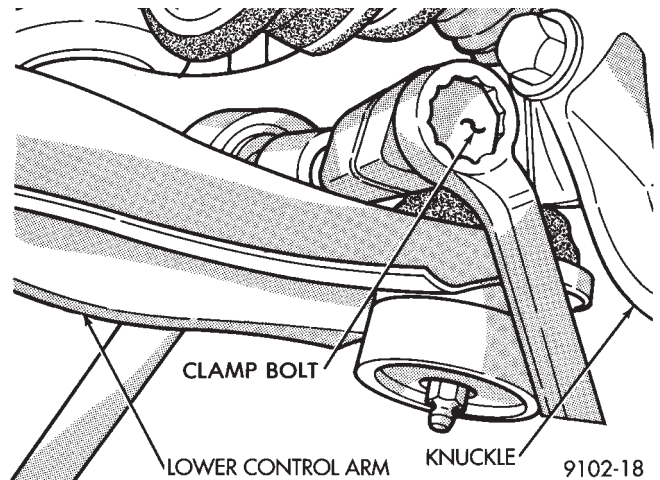

Fig. 14 Tighten Steering Knuckle Clamp Bolt

(7) Install the tie rod end into the arm of the steering knuckle. Install the tie rod end to steering knuckle attaching nut, and torque to 47 N•m (35 ft. lbs.). Install a new cotter pin into the tie rod end (Fig. 15).

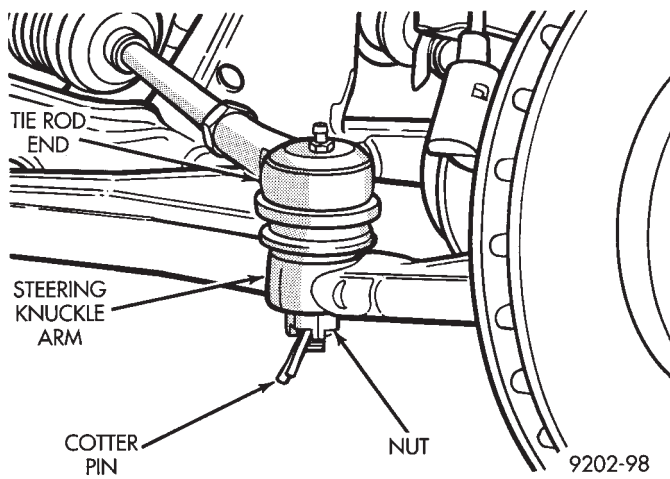

Fig. 15 Install Tie Rod End

(8) Install the braking disk back on the hub and bearing assembly (Fig. 5).

(9) Install the front brake caliper and adapter back over the braking disc and align with the adapter mounting holes on steering knuckle (Fig. 1). Install the caliper adapter to steering knuckle attaching bolts and torque to 217 N•m (160 ft. lbs.).

(10) Clean all foreign matter from the threads of the stub axle (Fig. 16). Install the washer and hub nut onto the threads of the stub axle and tighten nut.

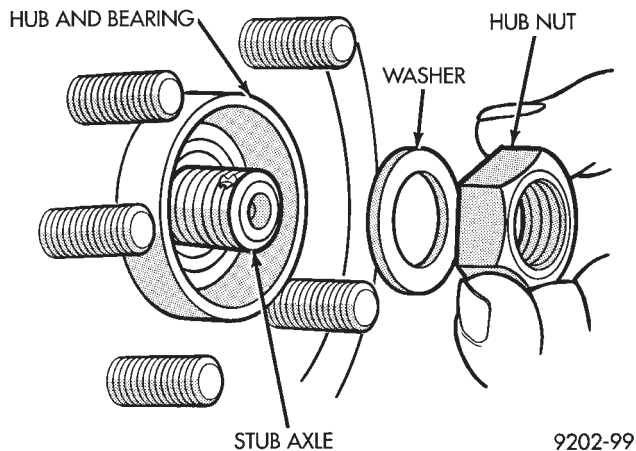

Fig. 16 Install Washer and Hub Nut

(11) With the vehicles brakes applied to keep front braking disc and hub from turning. Tighten the hub nut to a torque of 244 N•m (180 ft. lbs.) (Fig. 17).

(12) Install the spring washer, hub nut lock, and new cotter pin. Wrap the cotter pin prongs tightly around the hub nut lock (Fig. 18).

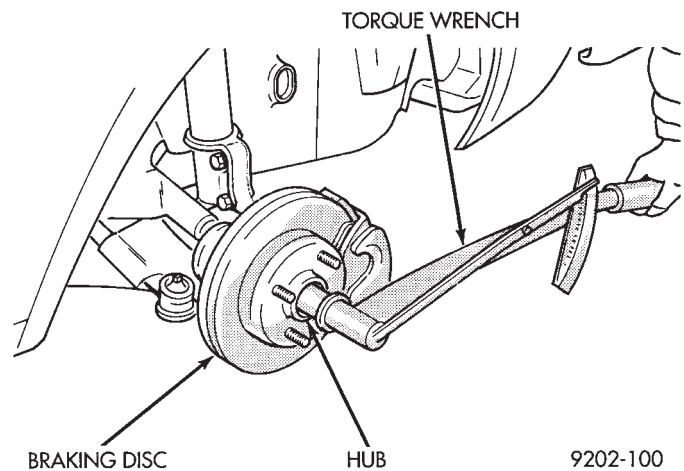

Fig. 17 Tighten Hub Nut

(13) Install the front wheel and tire assembly. Install the front wheel lug nuts and torque to 129 N•m (95 ft.lbs.).

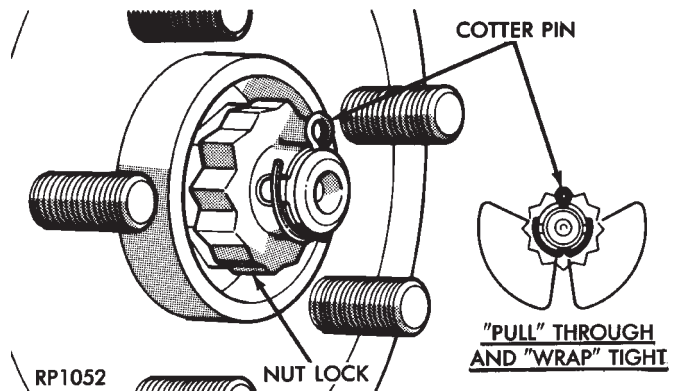

Fig. 18 Install Spring Washer, Nut Lock, & Cotter Pin

(14) Lower vehicle.

(15) Align the front wheels of the vehicle. Use the procedure listed under Wheel Alignment, in the Front Suspension Service Procedures section of this service manual.

HUB AND BEARING ASSEMBLY

The Unit III Front Hub and Bearing (Fig. 1) is used on all Caravan, Voyager and Mini Ram Vans.

All hub and bearing assemblies mount to the steering knuckle the same way, but vary by the wheel size on the vehicle. Vehicles equipped with 14 inch wheels have a 4 inch wheel mounting stud pattern. Vehicles equipped with 15 inch wheels have a 4 1/2 inch wheel mounting stud pattern. If a hub and bearing assembly needs to be replaced, be sure that the replacement assembly has the same size wheel mounting stud pattern as the original part.

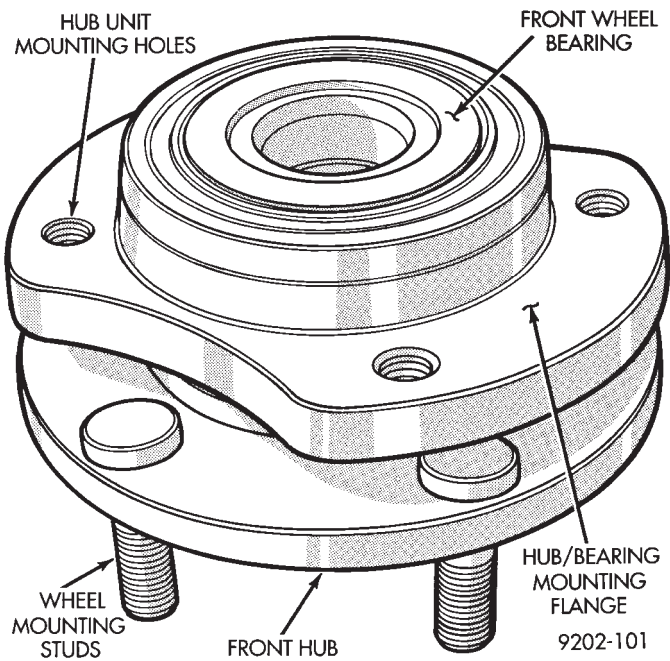

Fig. 1 Unit III Front Hub And Bearing Assembly

This unit is serviced only as a complete assembly (Fig. 1). It is mounted to the steering knuckle by four mounting bolts that are removed from the rear of the steering knuckle (Fig. 2).

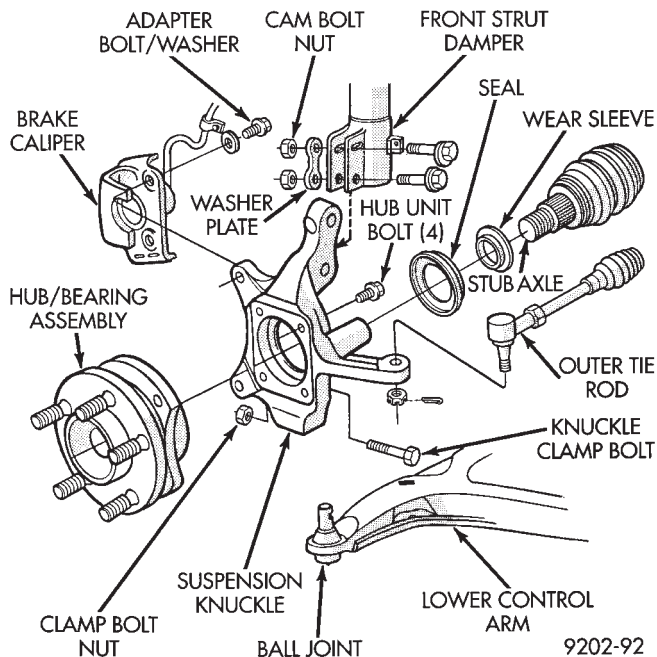

Fig. 2 Front Hub And Bearing Assembly Mounting

REMOVAL

Replacement of the front (drive) hub and bearing assembly can be done without having to remove the steering knuckle from the vehicle.

(1) Remove cotter pin, hub nut lock, and spring washer (Fig. 3).

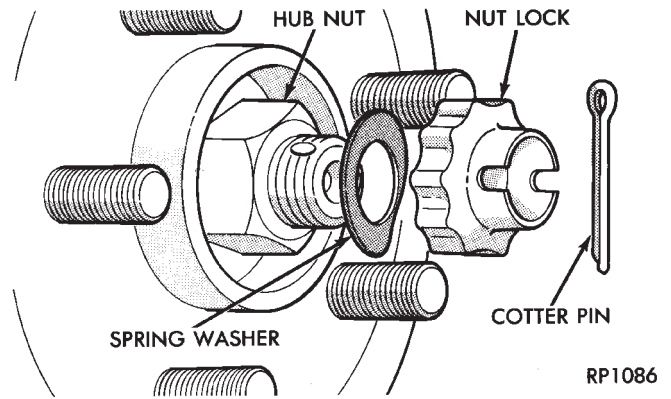

Fig. 3 Remove Cotter Pin, Nut Lock, & Spring Washer

(2) Loosen hub nut while the vehicle is on the floor with the brakes applied (Fig. 4). **The hub and drive-shaft are splined together through the knuckle (bearing assembly) and retained by the hub nut.**
 (3) Raise vehicle, see Hoisting Recommendations in

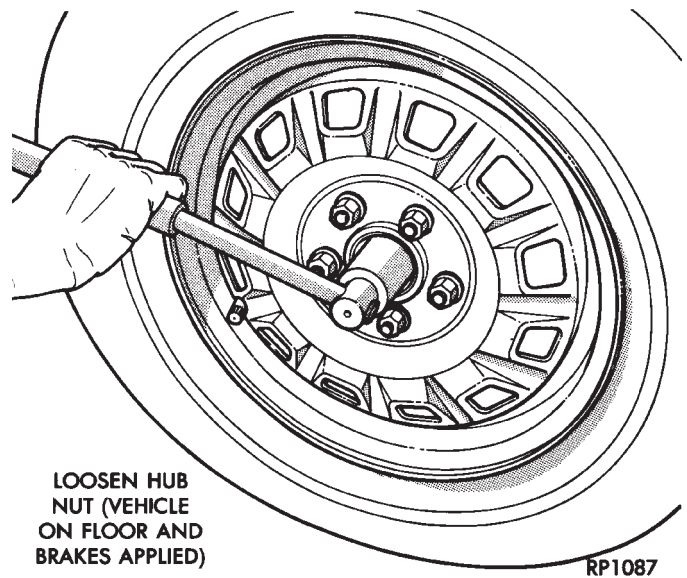

Fig. 4 Loosen Hub Nut

Group 0 of this service manual.

(4) Remove the hub nut and the washer from the stub axle (Fig. 3).

(5) Remove the wheel lug nuts, and tire and wheel assembly from the vehicle.



(6) Disconnect tie rod end from steering arm with Puller Special, Tool C-3894-A (Fig. 5).

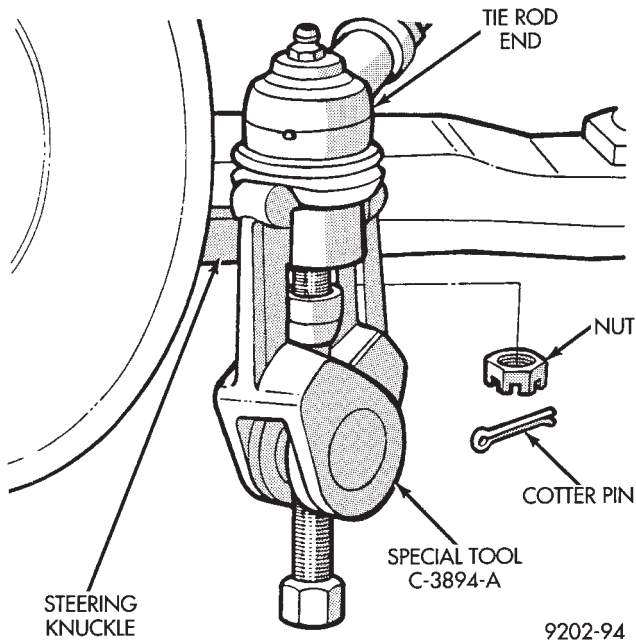

Fig. 5 Disconnect Tie Rod End

(7) Remove clamp bolt securing the ball joint stud into the steering knuckle (Fig. 6).

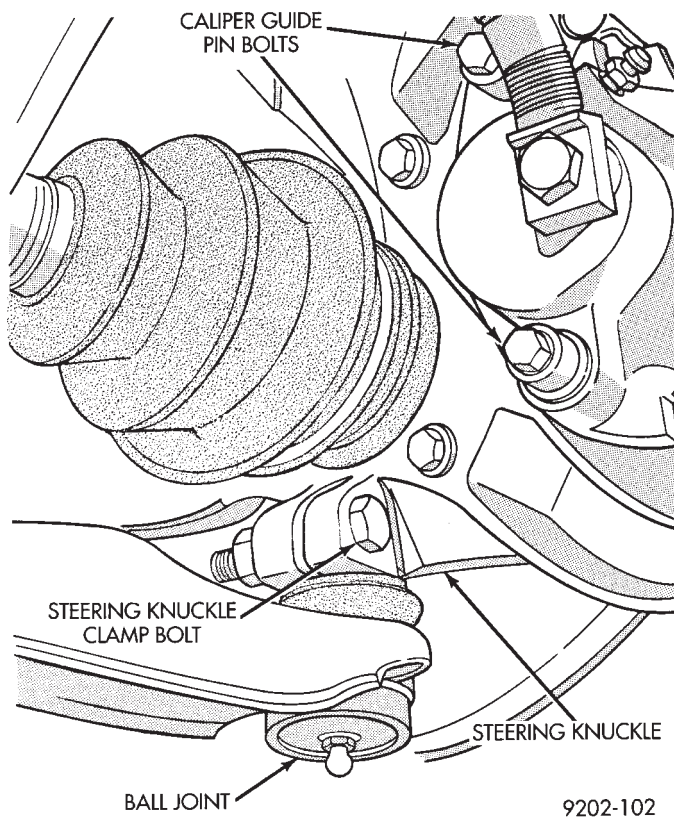

Fig. 6 Remove Clamp Bolt and Caliper Guide Pins

(8) Remove caliper guide pin bolts (Fig. 6) and separate caliper assembly from braking disc. **Support**

caliper with wire hook and not by hydraulic hose. (Fig. 7) Remove braking disc from hub and bearing assembly (Fig. 8).

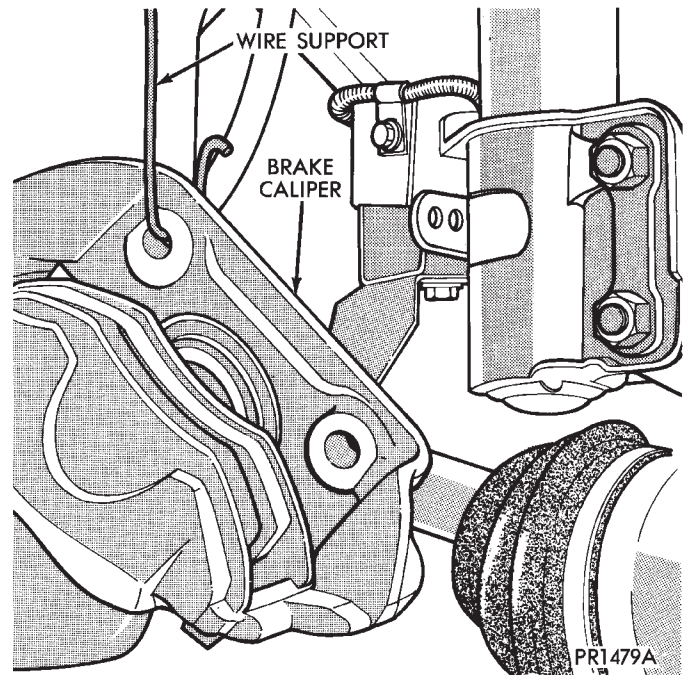

Fig. 7 Supporting Brake Caliper

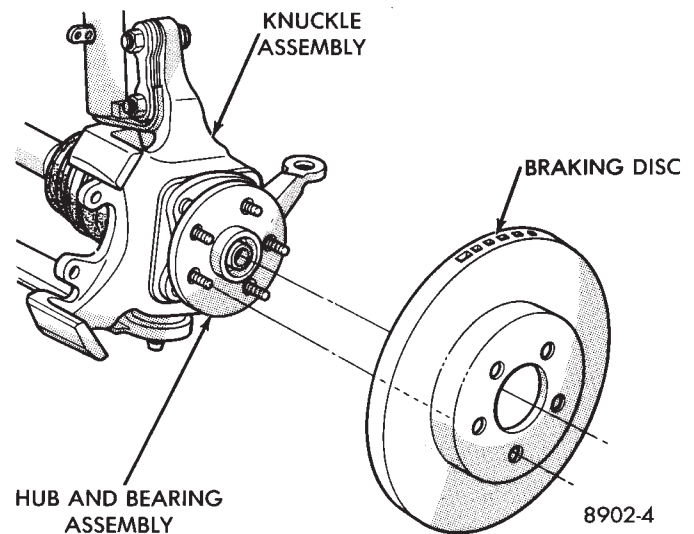

Fig. 8 Remove or Install Braking Disc

(9) Separate the steering knuckle assembly from the ball joint stud. Pull knuckle assembly out and away from driveshaft (Fig. 9).

Care must be taken not to separate the inner C/V joint during this operation. Do not allow driveshaft to hang by inner C/V joint, driveshaft must be supported.

(10) Remove the four hub and bearing assembly mounting bolts from rear of steering knuckle (Fig. 9).

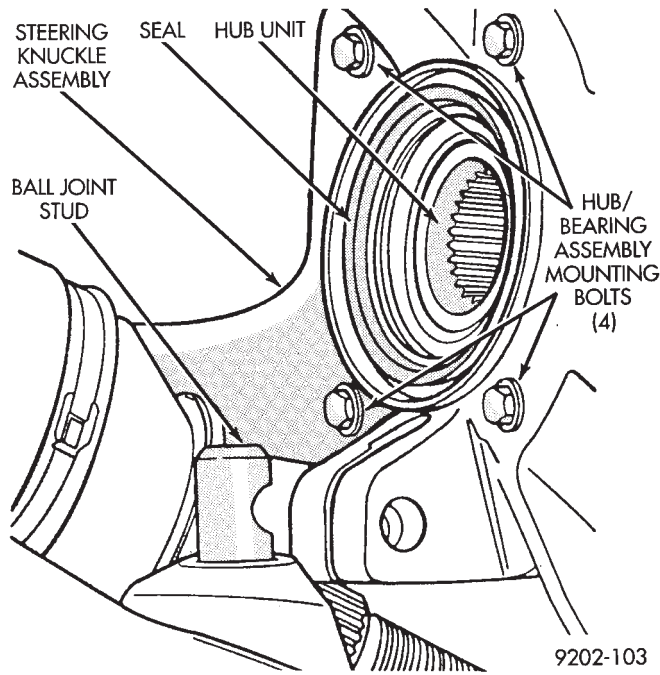

Fig. 9 Separate Ball Joint Stud from Steering Knuckle

(11) Remove the hub and bearing assembly from the steering knuckle (Fig. 10). **Replacement of the grease seal is recommended whenever this service is performed.**

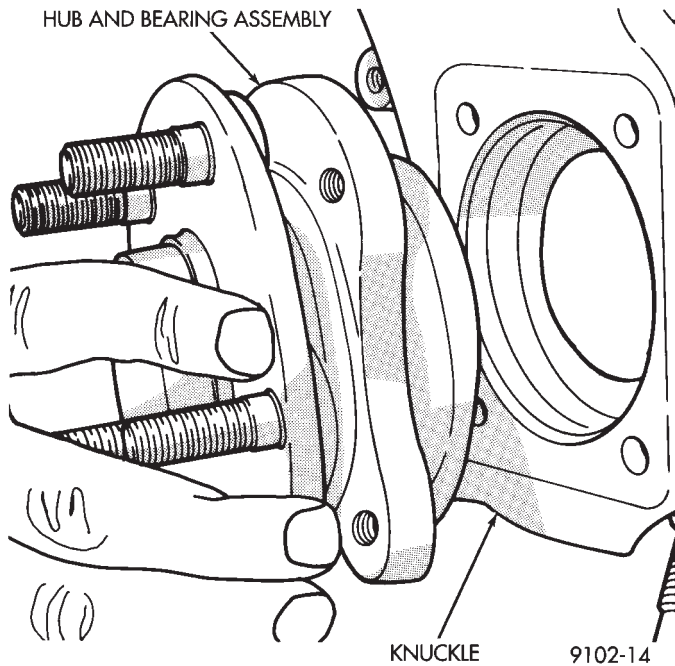

Fig. 10 Separate Hub and Bearing Assembly from Knuckle

INSTALLATION

CAUTION: All steering knuckle and bearing mounting surfaces must be smooth and completely free of foreign material or nicks.

(1) Install new front hub and bearing assembly into the steering knuckle. Tighten the hub and bearing assembly to steering knuckle attaching bolts (Fig. 9), in a criss-cross pattern to 65 N•m (45 ft. lbs.) torque.

(2) Position new hub and bearing assembly seal in recess of the steering knuckle (Fig. 11). Assemble Installer, Special Tool C-4698. Tool is provided with a handle and dual purpose drive head for installing seal into knuckle and (head reversed) for installing wear sleeve onto C/V joint housing.

(3) Using Special Tool C-4698 (Fig. 11) install the hub and bearing seal, until fully seated into the steering knuckle recess.

CAUTION: During any service procedures where

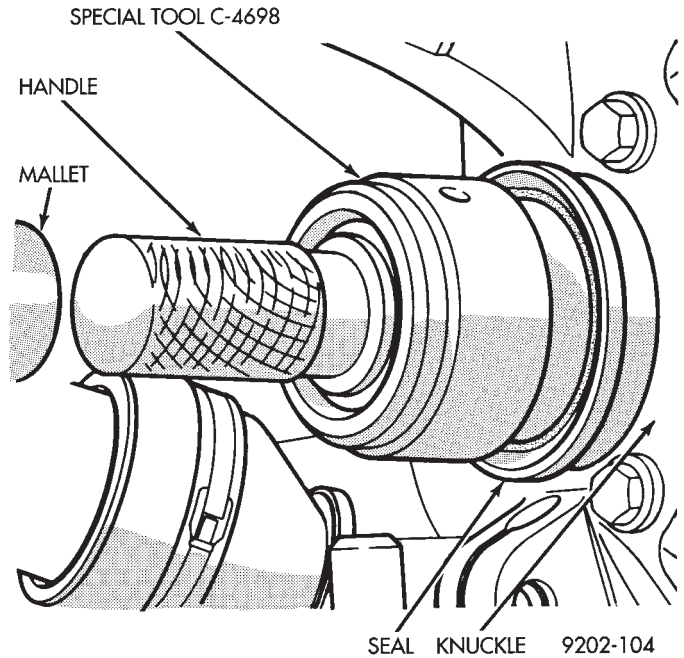

Fig. 11 Bearing Seal Installation

knuckle and driveshaft are separated, thoroughly clean seal and wear sleeve and lubricate BOTH components.

(4) Lubricate the FULL circumference of the bearing seal (and wear sleeve) as shown in (Fig. 12). With Mopar® Multi-Purpose Lubricant, or equivalent.

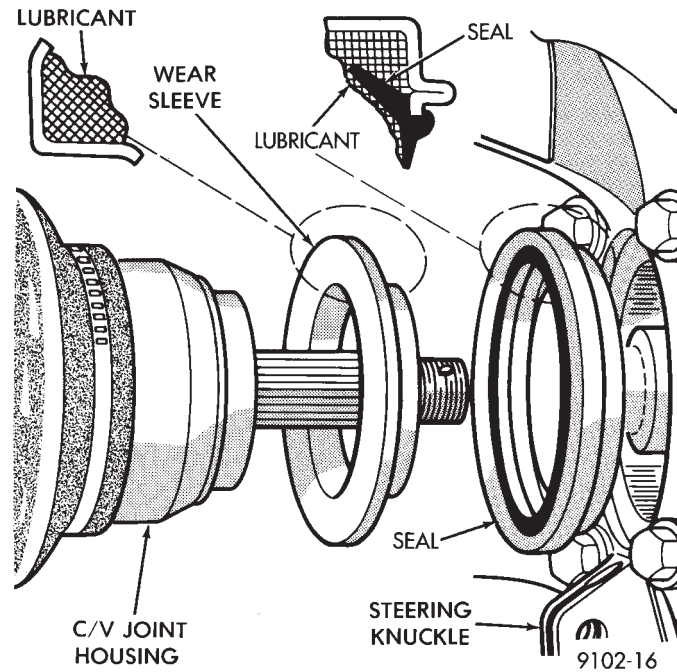

Fig. 12 Seal and Wear Sleeve Lubrication

(5) Insert driveshaft through hub and bearing assembly, while installing steering knuckle assembly on lower control arm ball joint stud (Fig. 13).

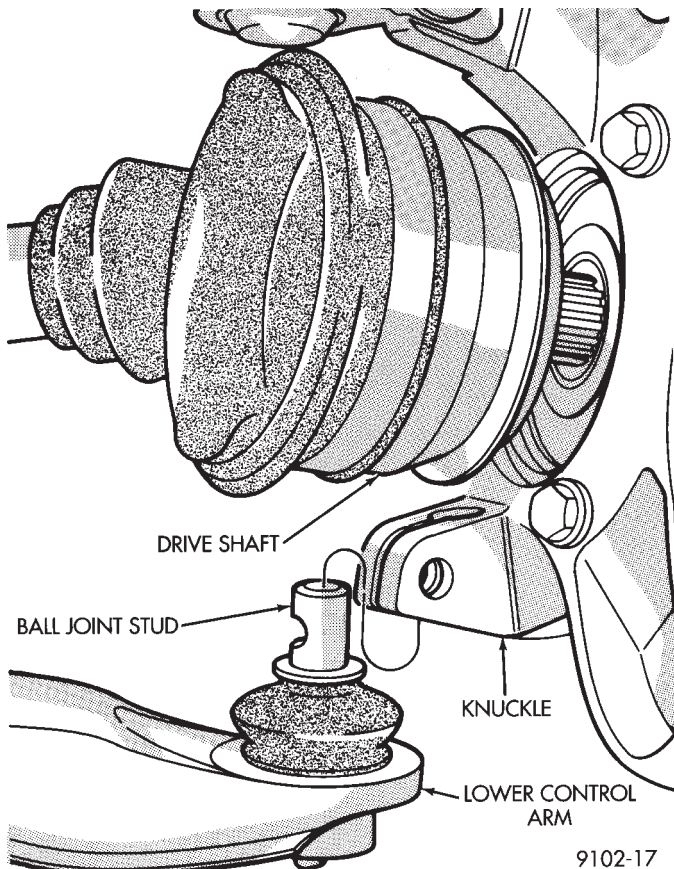

Fig. 13 Installing Knuckle Assembly

(6) Install original (or equivalent) ball joint to knuckle clamp bolt (Fig. 14) into steering knuckle. Tighten clamp bolt to 136 N•m (100 ft. lbs.) torque.

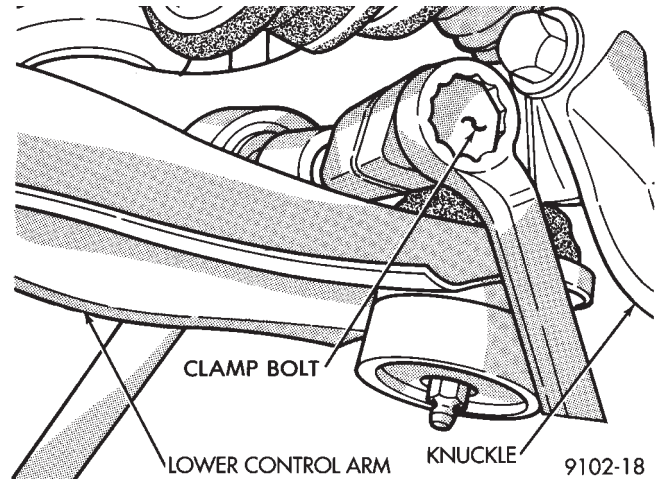

Fig. 14 Tighten Clamp Bolt

(7) Install tie rod end into steering knuckle arm (Fig. 15). Tighten tie rod to steering knuckle arm attaching nut to 47 N•m (35 ft. lbs.) torque and install cotter pin.

(8) Install braking disc (Fig. 8).

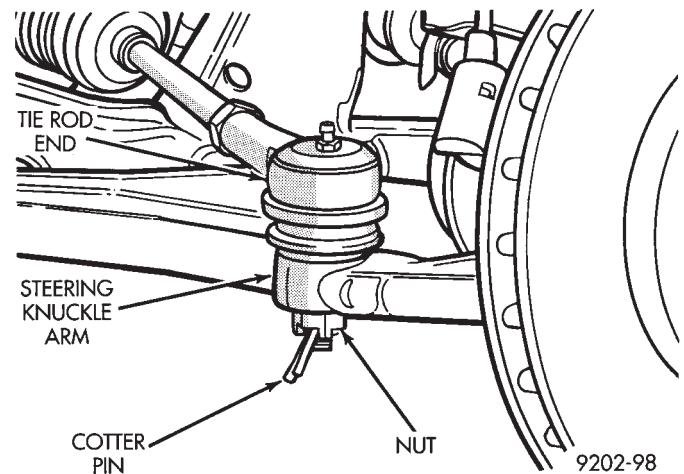

Fig. 15 Install Tie Rod End

(9) Carefully lower brake caliper assembly over braking disc (Fig. 16).

(10) Install brake caliper assembly guide pin bolts. Tighten guide pin bolts to 25-35 N•m (18-26 ft. lbs.) torque. **When installing guide pins, use extreme caution not to cross the threads.**

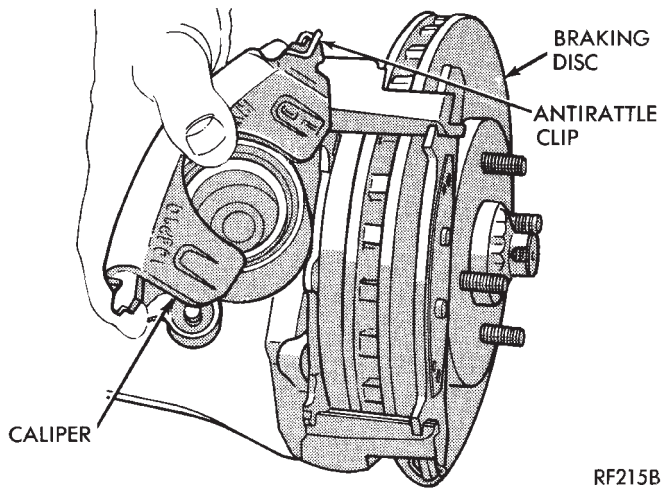

Fig. 16 Installing Family Caliper

(11) Clean all foreign matter from the threads of the stub axle (Fig. 17). Install the washer and hub nut (Fig. 17) onto the threads of the stub axle and tighten nut.

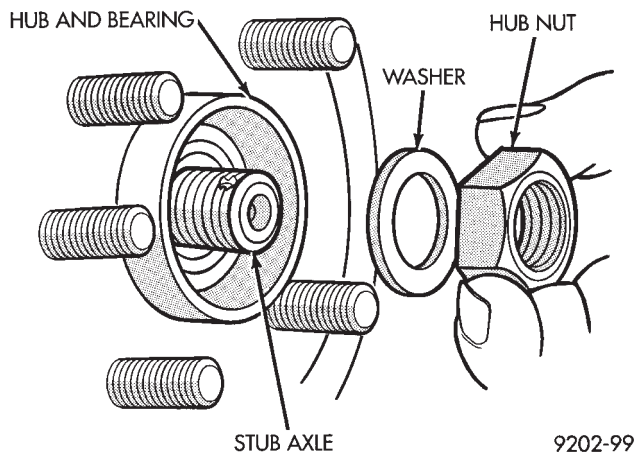

Fig. 17 Install Washer and Hub Nut

(12) With brakes applied, tighten front hub nut to (244 N•m) 180 ft. lbs. torque (Fig. 18).

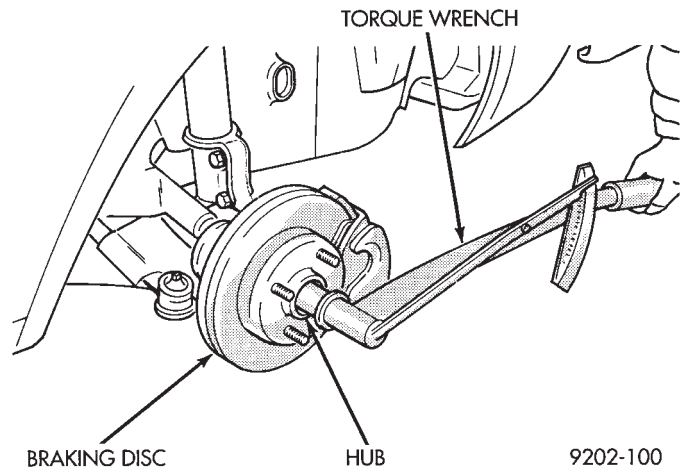

Fig. 18 Tighten Hub Nut

(13) Install spring washer, nut lock, and new cotter pin. Wrap cotter pin prongs tightly around nut lock (Fig. 19).

Install wheel and tire assembly. Tighten wheel nuts to 129 N•m (95 ft. lbs.) torque.

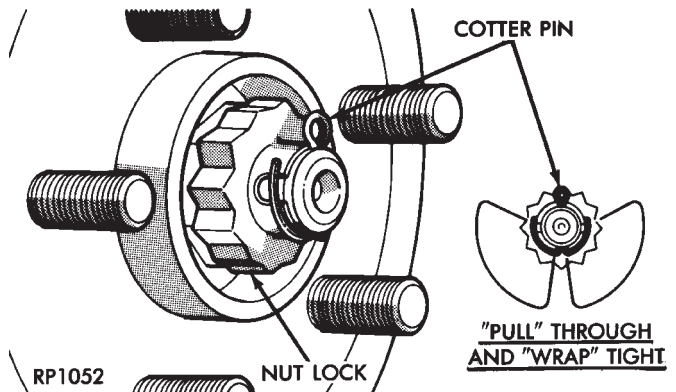

Fig. 19 Install Spring Washer, Nut Lock, & Cotter Pin



DRIVESHAFTS

INDEX

	page		page
C/V Joint Boots	40	Driveshaft Service Procedures	26
Damper Weights	45	General Information	26
Driveshaft Identification	26	Inner C/V Joint	31
Driveshaft Positioning Specifications	45	Outer C/V Joint	35
Driveshaft Reconditioning	31		

GENERAL INFORMATION

All Chrysler front wheel drive vans and wagons use only the unequal length driveshaft system.

The unequal length system has a short solid interconnecting shaft on the left side of the vehicle for all engine transmission applications. On the right side of the vehicle the interconnecting shafts vary depending on the transmission used in the vehicle. The manual transmission equipped vehicles use a tubular shaft and the automatic applications use a solid shaft (Fig. 1).

The driveshaft assemblies are three piece units. Each driveshaft has a tripod joint, an interconnecting shaft and a Rzeppa joint. The Tripod joint is splined into the transaxle side gear and the Rzeppa joint has a stub shaft that is splined into the wheel hub.

DRIVESHAFT IDENTIFICATION

Driveshafts used in front wheel van/wagon applications are identified by the driveshaft manufacturer. Vehicles can be equipped with any of these driveshaft assemblies. Each assembly can be identified as shown in (Fig. 2).

DRIVESHAFT SERVICE PROCEDURES

Procedures for the removal and installation of the driveshafts are essentially the same for all front wheel drive vehicles. Each driveshaft has a spring within the inboard tripod C/V joint that maintains constant engagement with the transaxle. This allows transaxle to be removed without dismantling part of the transaxle.

CAUTION: Boot sealing is vital to retain special lubricants and to prevent foreign contaminants from entering the C/V joint. Mishandling, such as allowing the assemblies to dangle unsupported, pulling or pushing the ends can cut boots or damage C/V joints. During removal and installation procedures always support both ends of the driveshaft to prevent damage.

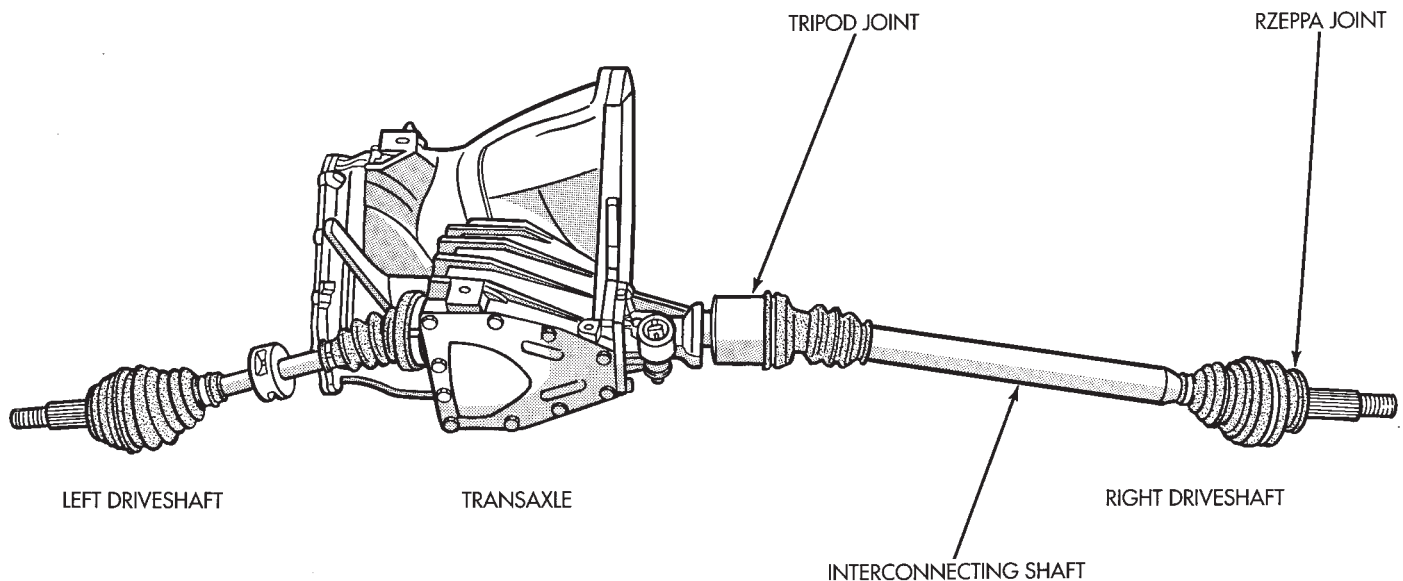

UNEQUAL LENGTH SYSTEM

9202-105

Fig. 1 Front-Wheel-Drive - Driveshaft System

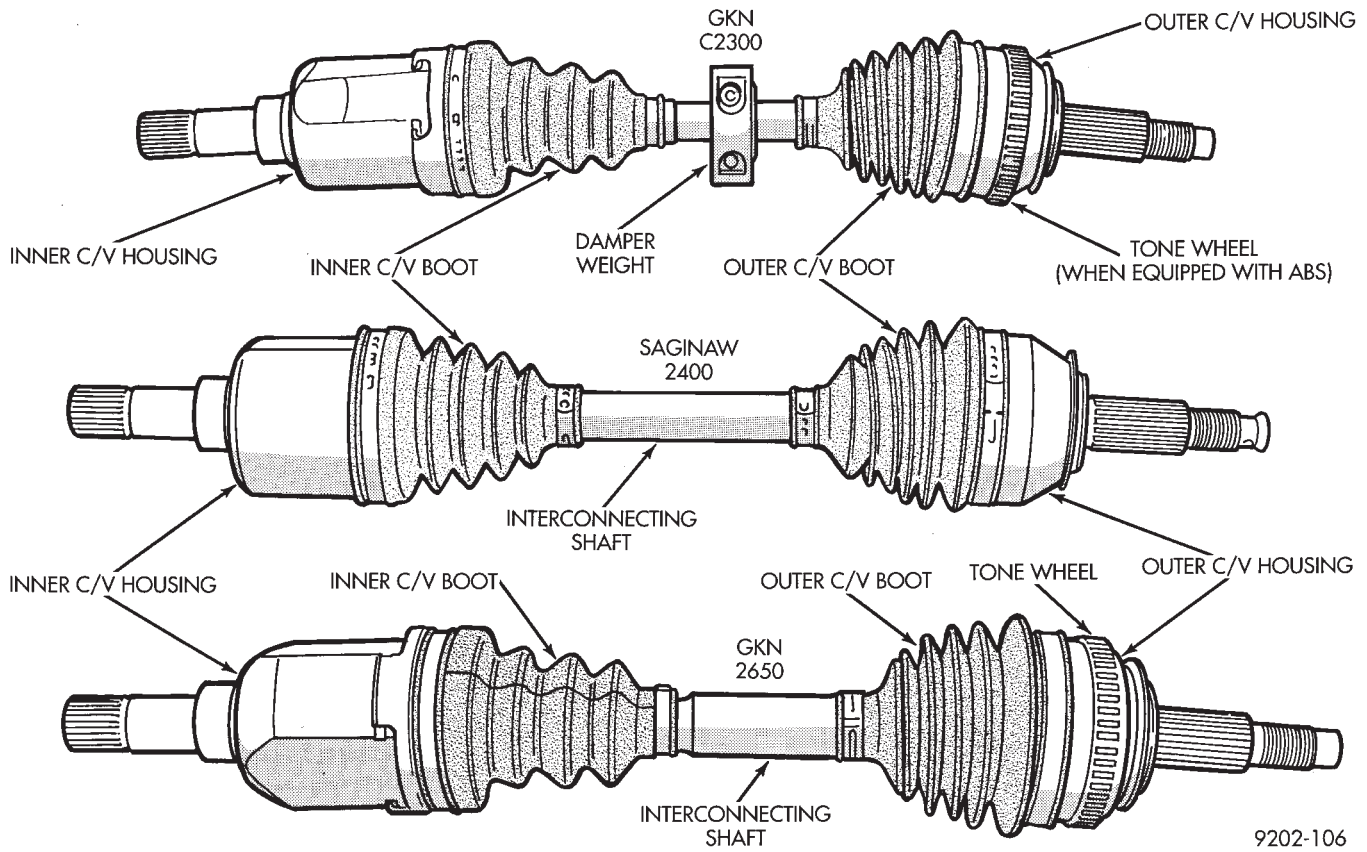

Fig. 2 Driveshaft Identification

HUB NUT AND HUB ASSEMBLY REMOVAL

Hub nut removal and installation is the same for all front wheel drive vehicles. For removal and installation procedures see **HUB NUT ASSEMBLIES INSTALL.**

(1) Remove front stub axle cotter pin, nut lock and spring washer (Fig. 1).

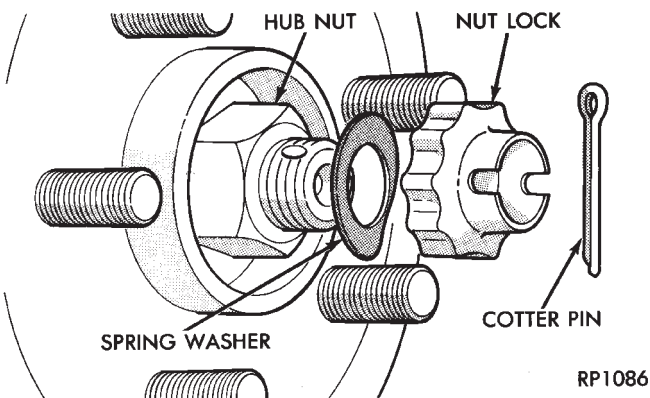

Fig. 1 Remove Cotter Pin, Nut Lock, & Spring Washer

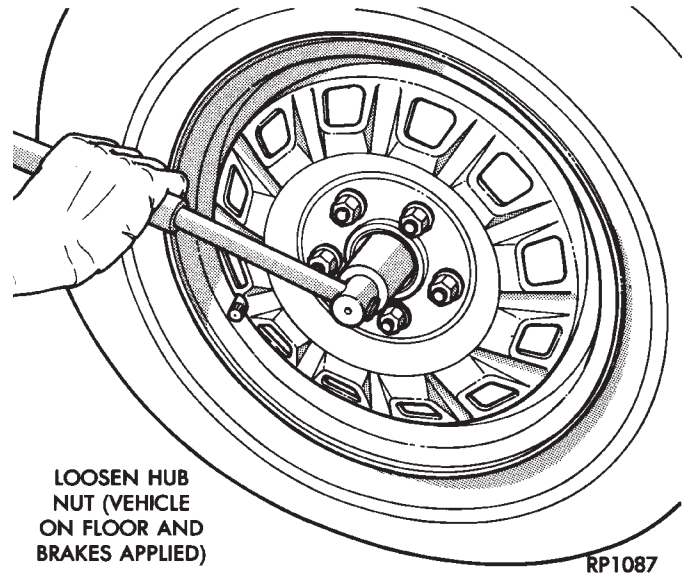

Fig. 2 Loosen Hub Retaining Nut & Wheel Nuts

(2) Loosen front hub nut and wheel nuts while vehicles is on floor and brakes applied (Fig. 2).

(3) Raise vehicle, see Hoisting in Lubrication and Maintenance, Group 0.

(4) Remove front hub nut and washer (Fig. 3).

(5) Remove the front wheel and tire assembly from the vehicle.

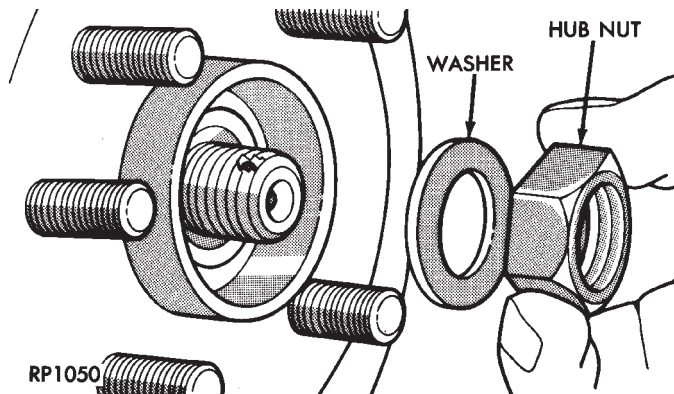

Fig. 3 Remove Hub Nut & Washer

DRIVESHAFT ASSEMBLIES

REMOVE

Inboard C/V joints have stub shafts splined into the differential side gears. Driveshafts are retained in the side gears by a constant force provided by a spring contained within the inboard C/V joints.

(1) Before performing removal of the vehicles right side driveshaft assembly. The speedometer pinion must be removed from the transaxle assembly (Fig. 4).

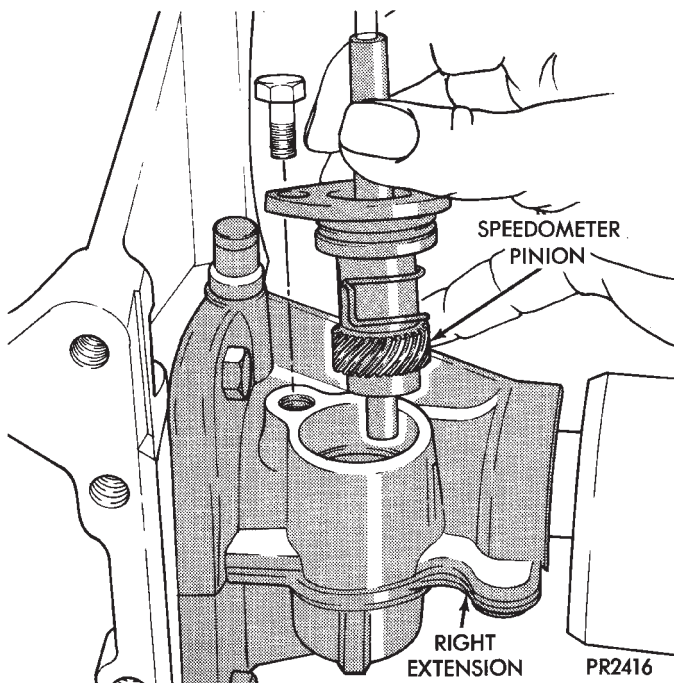

Fig. 4 Remove Speedometer Pinion (for Right Driveshaft)

(2) Remove clamp bolt securing ball joint stud into steering knuckle (Fig. 5).

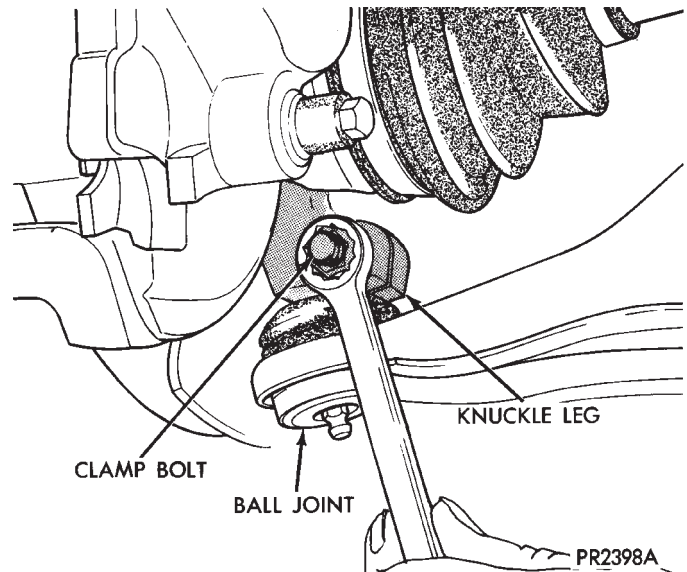

Fig. 5 Remove Ball Joint to Steering Knuckle Clamp Bolt

(3) Separate ball joint stud from steering knuckle by prying against knuckle leg and control arm (Fig. 6).

CAUTION: Do not damage ball joint or C/V joint boots (Fig. 6).

(4) Separate outer C/V joint splined shaft from hub

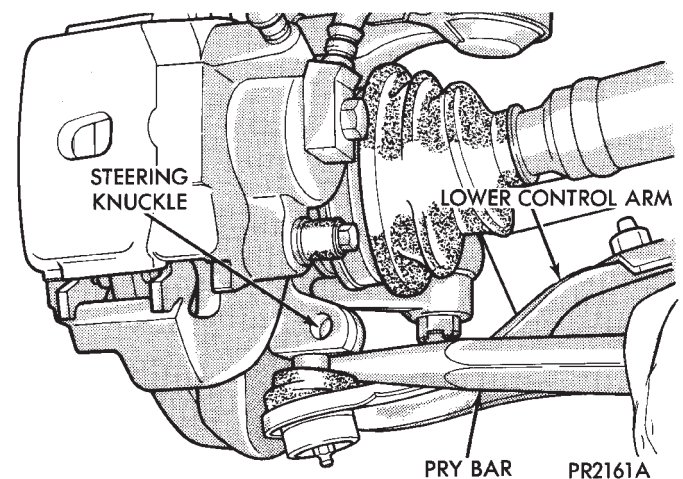

Fig. 6 Separate Ball Joint from Knuckle

by holding C/V housing while moving knuckle (hub) assembly away (Fig. 7).

CAUTION: Do not pry on or otherwise damage wear sleeve on outer C/V joint.

(5) Support assembly at C/V joint housings. Remove by pulling outward on the inner joint housing. **DO NOT PULL ON SHAFT** (Fig. 8).

The driveshaft, when installed, acts as a bolt and secures the hub/bearing assembly. If the vehicle is to be supported or moved on its wheels.

Install a bolt through the hub to ensure that the hub bearing assembly cannot loosen.

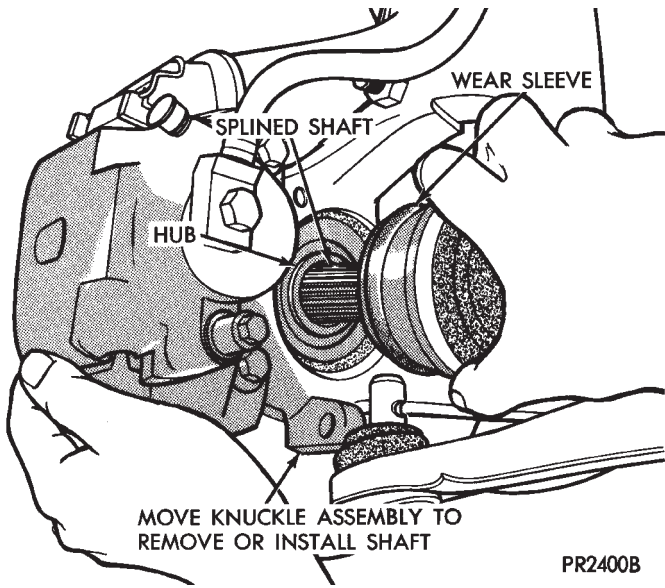

Fig. 7 Separate Outer C/V Joint Shaft from Hub

INSTALL

(1) Hold inner joint assembly at housing (Figs. 8 and 9) while aligning and guiding the inner joint spline into the transaxle or intermediate shaft assembly.

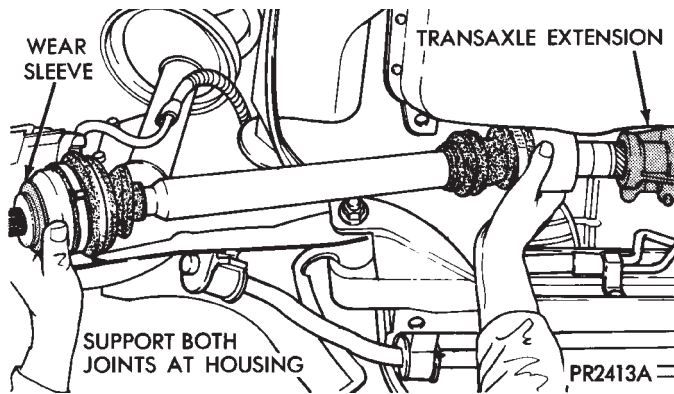

Fig. 8 Removing Driveshaft Assembly Unequal Length

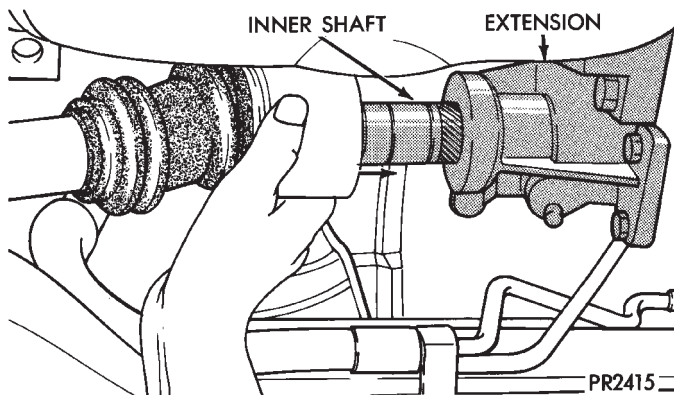

Fig. 9 Installing Inner Shaft into Transaxle

CAUTION: Follow this Seal/Wear sleeve lubrication during any service procedures where knuckle and driveshaft are separated. Thoroughly clean seal and wear sleeve with suitable solvent (solvent must not touch boot) and lubricate both components prior to installing driveshaft. Lubricate wear sleeve and seal with Mopar® Multi-Purpose Lubricant, or equivalent.

Apply on the full circumference of the Wear Sleeve a bead of lubricant that is 6 mm (1/4 in.) wide to seal contact area (Fig. 10). Fill lip to housing cavity on Seal, complete circumference, and wet seal lip with lubricant (Fig. 10).

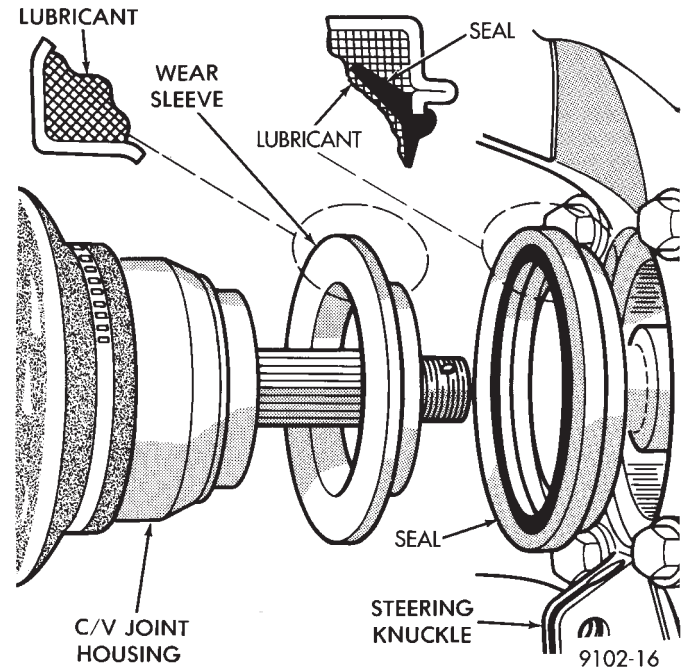

Fig. 10 Seal & Wear Sleeve Lubrication

(2) Push knuckle (hub) assembly out and install splined outer C/V joint shaft in hub (Fig. 11).

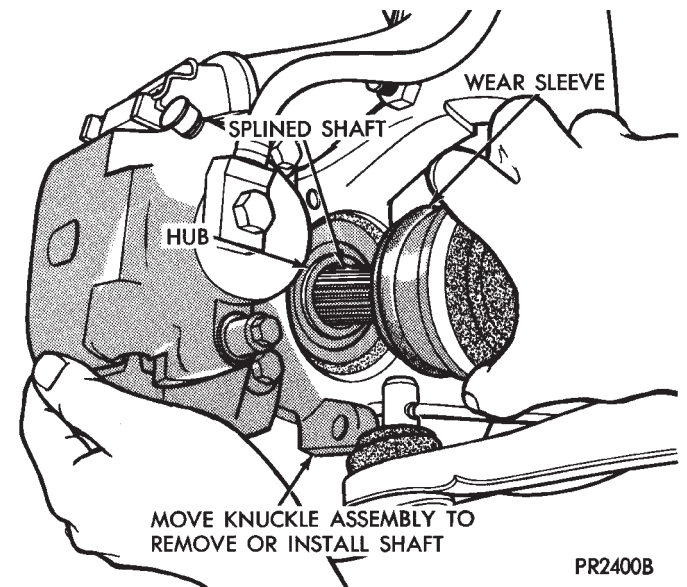

Fig. 11 Install Outer Shaft into Hub

(3) Install steering knuckle assembly on ball joint stud (Fig. 12).

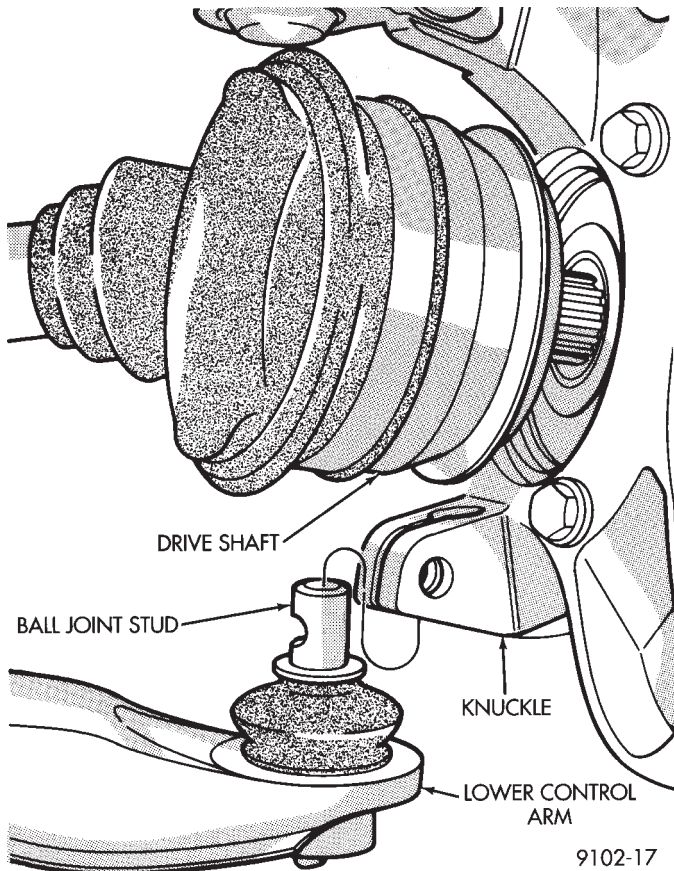

Fig. 12 Install Knuckle Assembly on Ball Joint Stud

CAUTION: Steering knuckle clamp bolt shown in Figs. 12 and 13 is prevailing torque type, original or equivalent bolt must be installed during assembly.

(4) Install and tighten clamp bolt to 136 N•m (100 ft. lbs.) torque (Fig. 13).

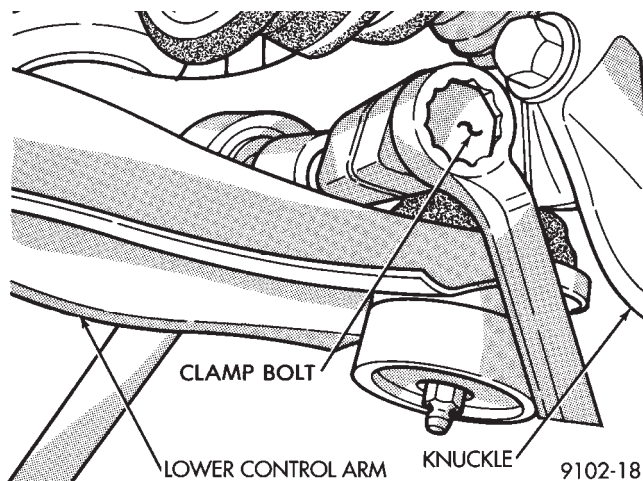

Fig. 13 Tighten Clamp Bolt

(5) Install speedometer pinion (Fig. 14).

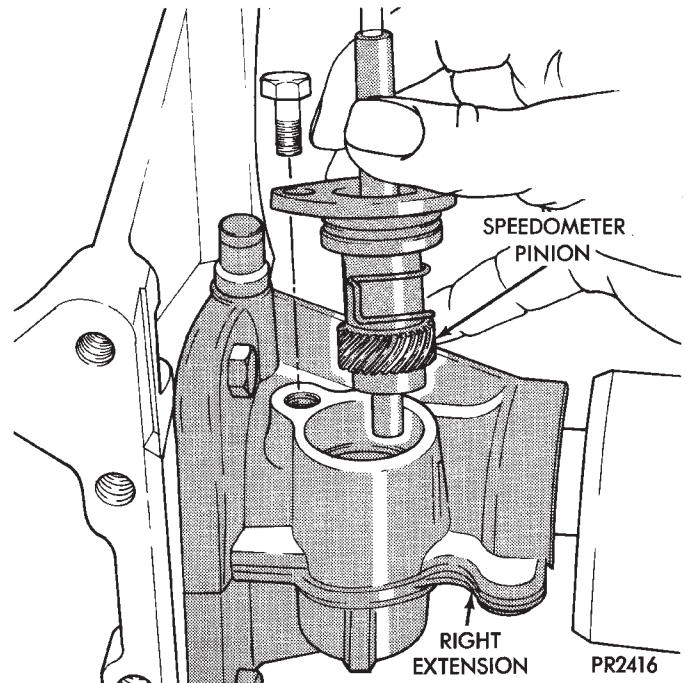

Fig. 14 Install Speedometer Pinion

(6) Fill differential with proper lubricant (see Lubrication and Maintenance Group 0).

(7) Install front hub nut assembly.

(8) If after installing the driveshaft assembly, the **inboard** boot appears collapsed or deformed. Vent the inner boot by inserting a round tipped small diameter rod between the boot and shaft. If necessary, massage the boot to remove all puckers being careful not to allow dirt to enter or grease to leave the boot cavity. If the boot is clamped to the shaft with a rubber garter clamp, it need not be removed to perform this venting operation. If the boot is clamped to the shaft using a metal clamp, the clamp must be removed and discarded before the rod can be inserted. After venting, install a **new** Service Clamp, or equivalent using special Tool C-4653 (see Boots Install section at the end of this group for details).

HUB NUT ASSEMBLIES INSTALL

The front wheel hub nuts use a lock nut and cotter pin to maintain proper wheel bearing preload and prevent the nut from backing off. Install the assembly as follows.

(1) Install washer and hub nut after cleaning any foreign matter from stub axle threads (Fig. 15).

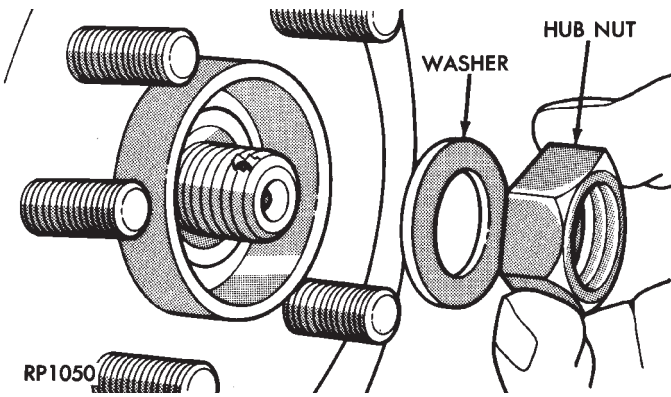

Fig. 15 Install Washer and Hub Nut

(2) With brakes applied, tighten hub nut to 245 N•m (180 ft. lbs.) torque (Fig. 16).

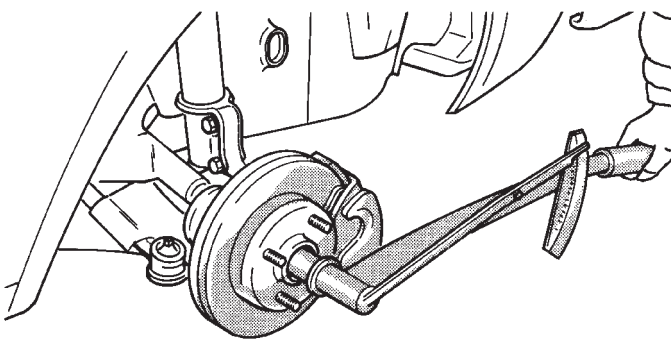

Fig. 16 Tighten Hub Nut

(3) Install nut lock, spring washer and **NEW** cotter pin. Wrap cotter pin prongs tightly around nut lock (Fig. 17).

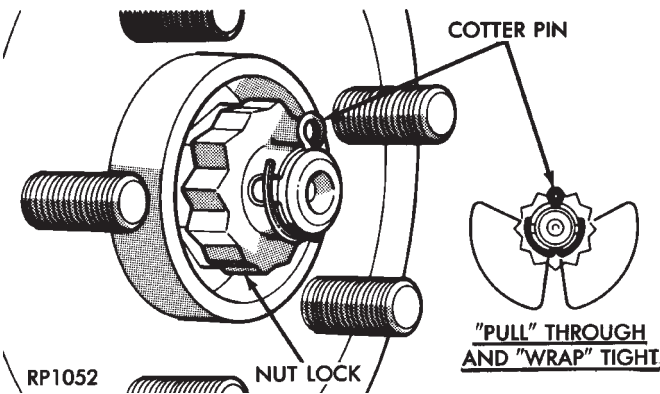

Fig. 17 Install Spring Washer, Nut Lock, and New Cotter Pin

(4) Install wheel and tire assembly. Tighten wheel nuts to 129 N•m (95 ft. lbs.) torque (Fig. 18).

DRIVESHAFT RECONDITIONING

Driveshaft reconditioning and/or boot replacement for all front wheel drive vehicles is essentially the same per C/V joint.

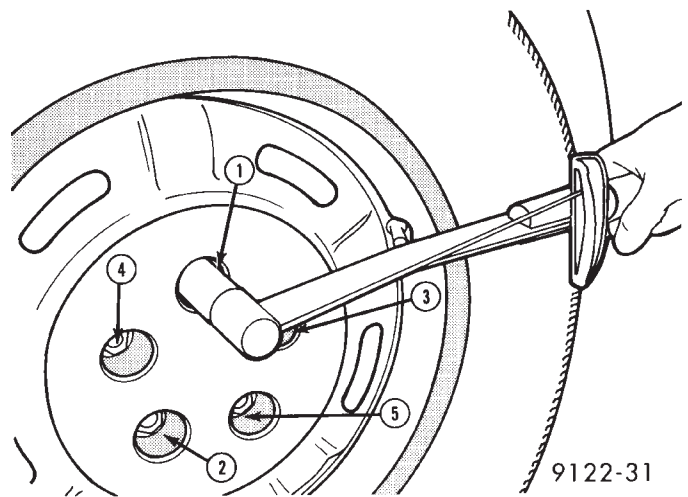

Fig. 18 Install Wheel & Tire Assembly

Note that lubricant requirements and quantities are different for inner joints than for outer joints, and type being serviced. Use only the recommended lubricants.

Complete driveshaft components are shown in (Fig. 1).

Driveshaft requirements are different for various vehicle models, engines, and transaxles, and often change from one model year to the next.

Driveshaft parts will be different to accommodate this. Therefore, when replacing parts, be sure to use only those specified in the service parts catalog for the exact model year, model, engine, transaxle, and type being serviced.

INNER C/V JOINT

DISASSEMBLE

With the driveshaft removed from the vehicle, identify the unit type (See Fig. 2 under Driveshafts Identification).

(1) Remove the boot clamps and pull back the boot to gain access to the tripod retention system, which prevents accidental separation from the C/V joint housing.

CAUTION: When removing the housing from the tripod, hold the rollers in place on the trunnion studs to prevent the rollers and needle bearings from falling away. After the tripod is out of the housing secure the rollers in place with tape (Fig. 4).

(2) Depending on the type of C/V joint assembly, separate the C/V joint housing from the tripod as follows:

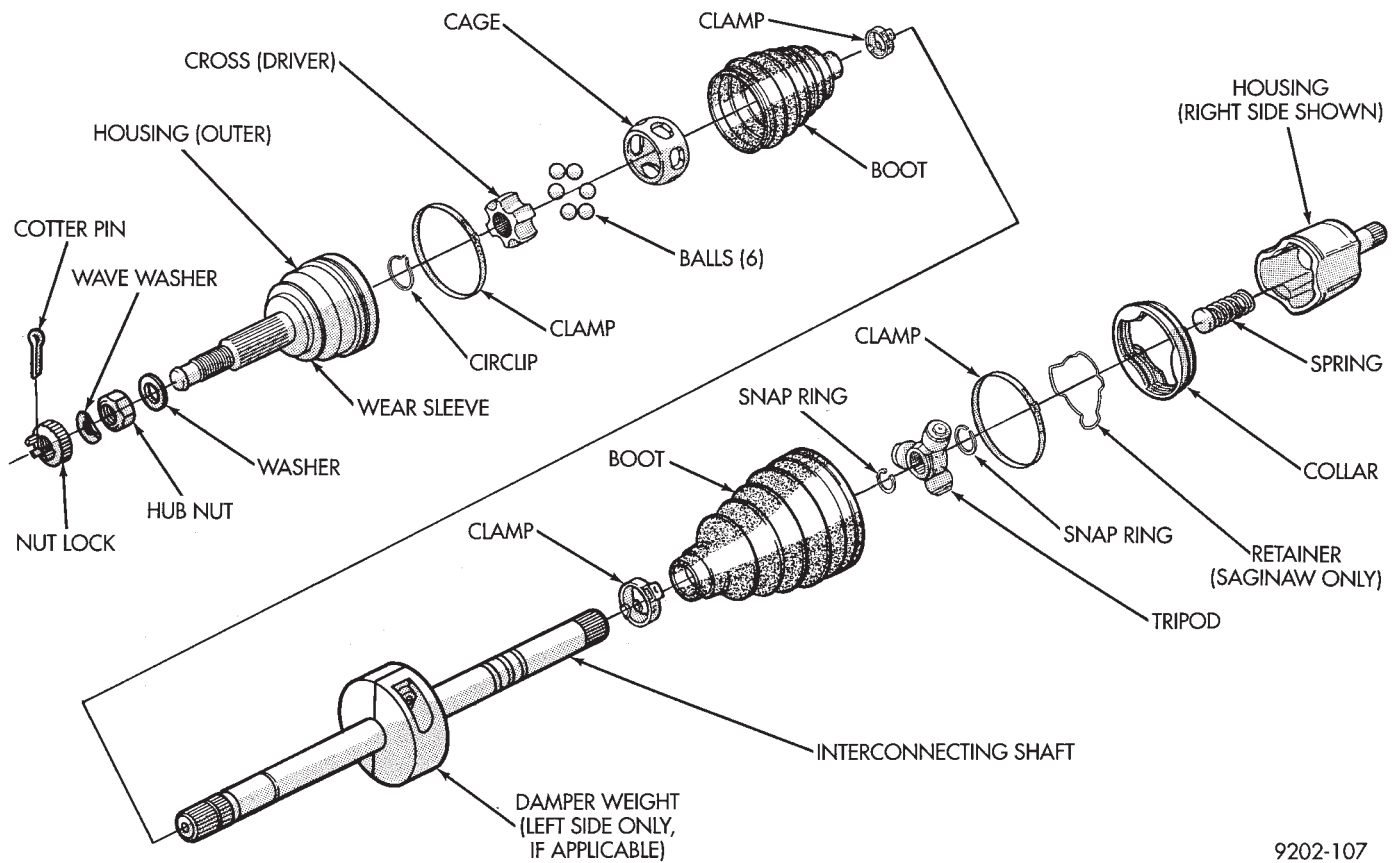

9202-107

Fig. 1 Driveshaft Components

S.S.G. Utilizes a wire ring tripod which expands into a groove around the top of the housing. Use a flathead screwdriver to pry the wire ring out of the groove and slide the tripod from the housing (Fig. 2). **Do not mangle or destroy retainer during disassembly.**

caps on jaws of vise to prevent damage to stub shaft. Hold the interconnecting shaft on an angle, while gently pulling on the shaft until one of the tripod bearings is free of the retaining collar. Continue holding the interconnecting shaft on an angle and gently pull on the shaft until all rollers are free of the retaining collar. See (Fig. 3).

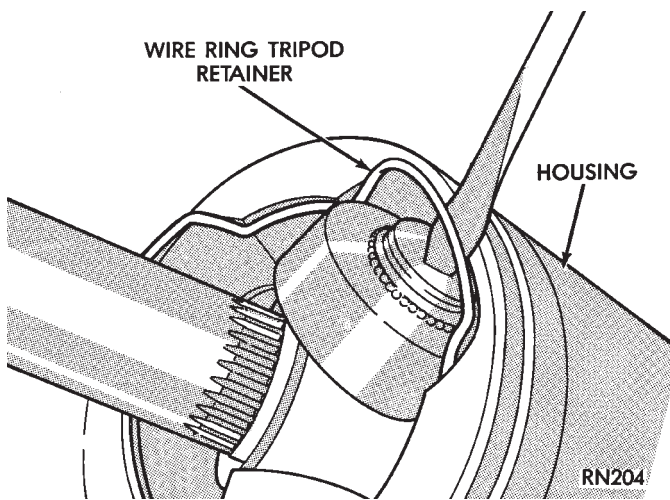

Fig. 2 Separate Tripod From Housing S.S.G.

G.K.N. The retention system on this assembly is an integral part of the plastic collar on the inside of the C/V joint housing. Clamp the stub shaft of the C/V joint housing in a vise, use protective

TRIPOD ASSEMBLY REMOVAL FROM INTERCONNECTING SHAFT

S.S.G. AND G.K.N. WITH SINGLE RING TRIPOD RETENTION.

Remove the tripod assembly to interconnecting shaft retaining snap ring from the interconnecting shaft end groove (Fig. 4). Remove the tripod assembly from the interconnecting shaft by hand or by tapping the body of the tripod assembly with a brass punch (Fig. 5).

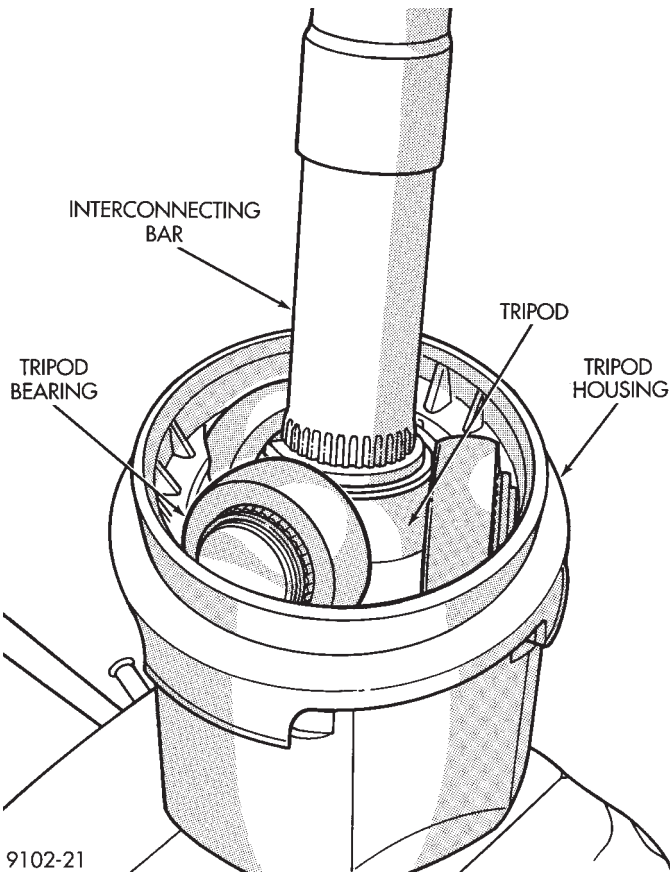

9102-21
Fig. 3 Separate Tripod From Housing G.K.N.

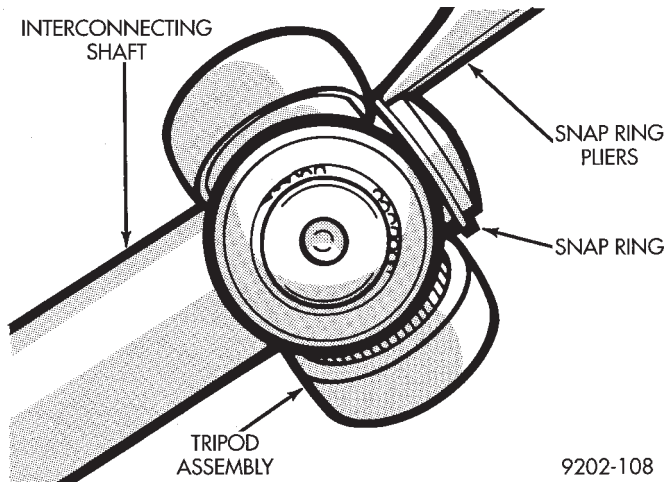

9202-108
Fig. 4 Outer Tripod Retaining Snap Ring Removal G.K.N. WITH DOUBLE RING TRIPOD RETENTION.

(1) Expand and remove the outer tripod assembly to interconnecting shaft, retaining snap ring (Fig. 6).

(2) Remove the tripod assembly from the interconnecting shaft. Tripod can be removed either by hand or by tapping the tripod body with a brass drift (Fig. 5). Do not hit the outer tripod bearings in an attempt to remove tripod assembly from interconnecting shaft.

(3) Remove the inner tripod assembly to interconnecting shaft, retaining snap ring from the of interconnecting shaft (Fig. 7).

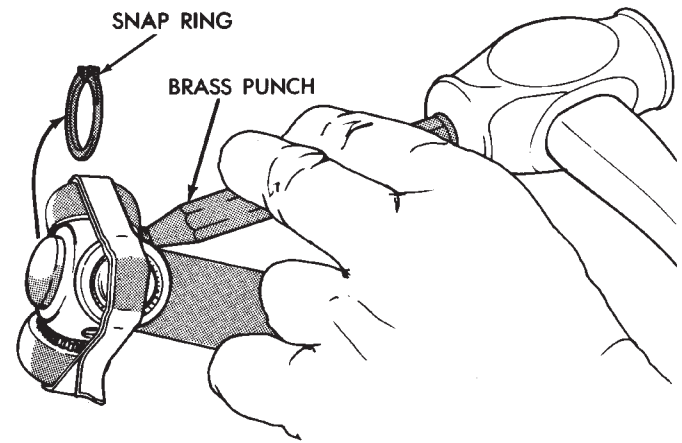

PR2423C
Fig. 5 Tripod Assembly Removal From Interconnecting Shaft

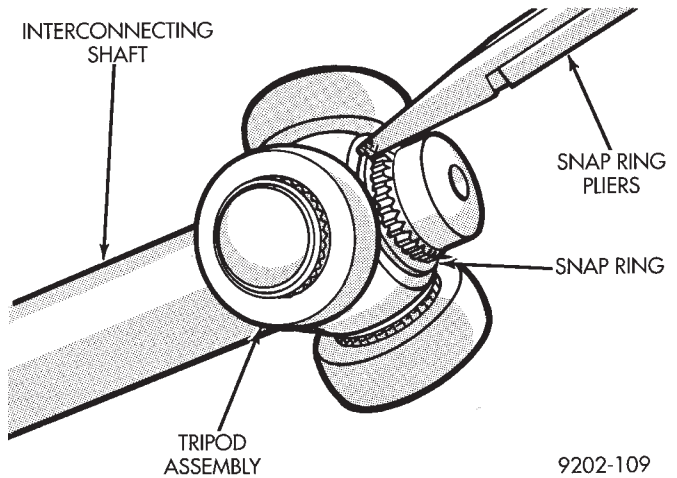

9202-109
Fig. 6 Removing Outer Tripod Retaining Snap Ring (G.K.N.)

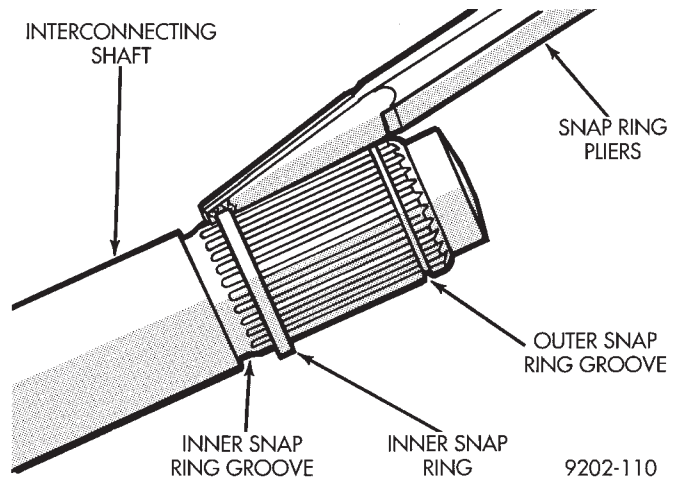

9202-110
Fig. 7 Removing Inner Tripod Retaining Snap Ring (G.K.N.)

INSPECT TRIPOD AND HOUSING

Remove as much grease as possible from assembly and inspect joint housing ball raceway and tripod components for **EXCESSIVE** wear and replace if necessary.

Inspect the spring, spring cup, and the spherical end of the connecting shaft for **EXCESSIVE** wear or damage and replace, if necessary.

ASSEMBLE CV JOINT**TRIPOD ASSEMBLY INSTALLATION S.S.G. & G.K.N. WITH SINGLE RING RETENTION**

(1) Fasten the (new) boot to the interconnecting shaft. See Boots Install.

(2) Install the tripod assembly onto the interconnecting shaft until it is past the snap ring groove on the shaft (Fig. 8). If required the tripod assembly can be tapped onto the interconnecting shaft using a brass drift, on the body of the tripod assembly (Fig. 5). Do not hit the outer tripod assembly bearings in an attempt to install tripod on interconnecting shaft.

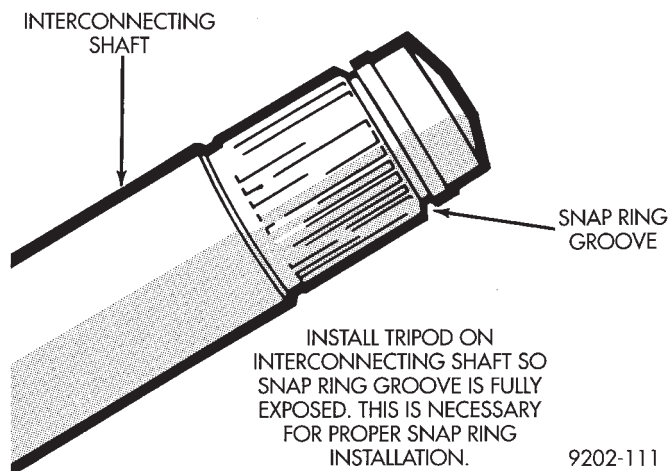
**Fig. 8 Interconnecting Shaft Snap Ring Groove**

(3) Install a **NEW** outer tripod assembly to interconnecting shaft retaining snap ring, into the interconnecting shaft snap ring groove (Fig. 9). Be sure that the snap ring is fully seated into the snap ring groove around the entire interconnecting shaft.

TRIPOD ASSEMBLY INSTALLATION G.K.N. WITH DOUBLE RING RETENTION

(1) Fasten the (new) boot to the interconnecting shaft. See Boots Install.

(2) Install the inner tripod assembly retaining snap ring into the retaining groove on the interconnecting shaft (Fig. 10).

(3) Install the tripod assembly onto the interconnecting shaft until it is past the outer snap ring groove on the shaft (Fig. 10). If required the tripod assembly can be tapped onto the interconnecting shaft using a brass drift, on the body of the tripod assembly (Fig. 5).

Do not hit the outer tripod assembly bearings in an attempt to install tripod on interconnecting shaft.

(4) Install the outer tripod assembly to intermediate shaft retaining snap ring into the snap ring groove on the intermediate shaft (Fig. 11).

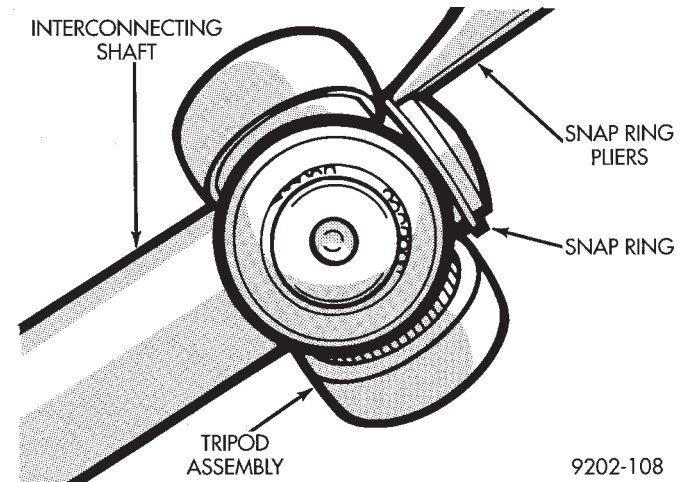
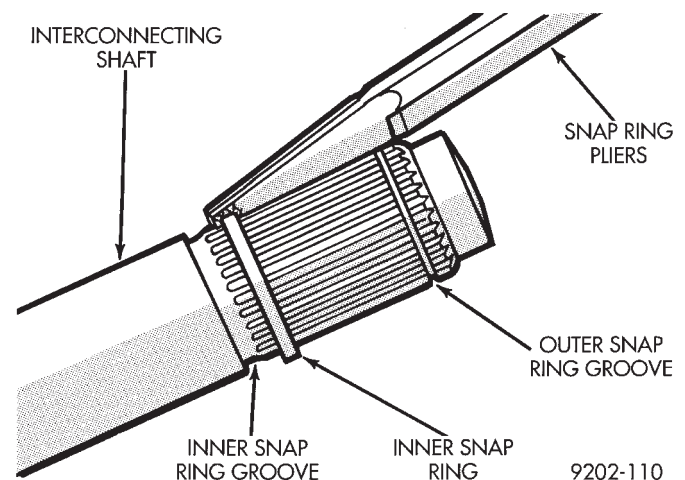
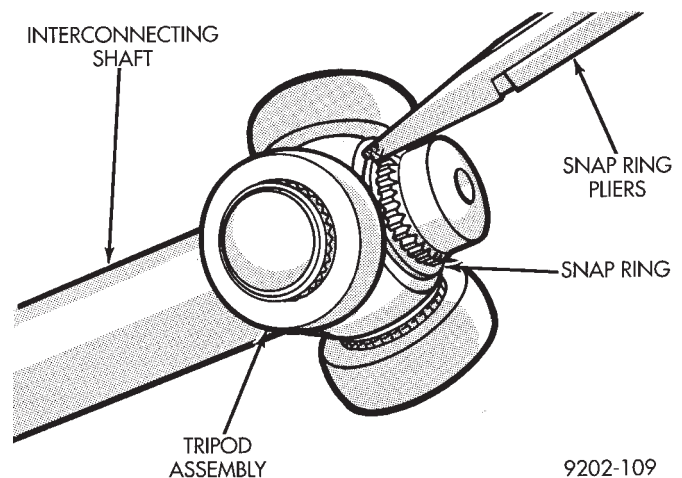
**Fig. 9 Outer Tripod Retaining Snap Ring Installation****Fig. 10 Inner Snap Ring Installation****Fig. 11 Outer Snap Ring Installation**

INNER C/V JOINT HOUSING INSTALLATION

G.K.N. Assembly

(1) Distribute 1/2 the amount of the grease provided into the housing and the remaining amount into the boot.

(2) Position the spring in the housing spring pocket with the spring cup attached to the exposed end of the spring (Fig. 12). Place a small amount of grease on the concave surface of the spring cup.

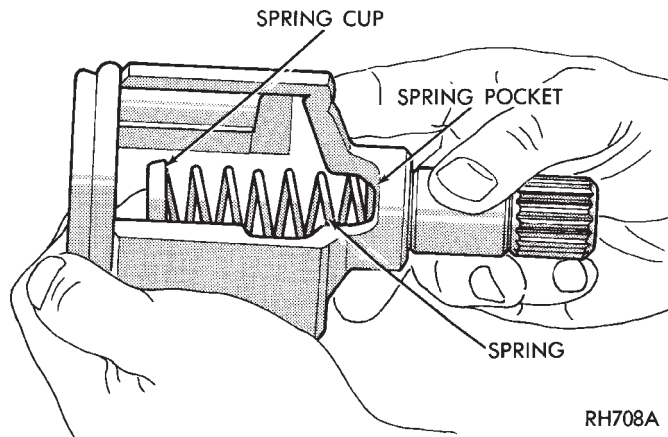

Fig. 12 Spring and Cup Installation

CAUTION: Care must be taken to ensure proper spring positioning. The spring must remain centered in the housing spring pocket when the tripod is installed and seated in the spring cup (Fig. 12).

(3) Clamp the stub shaft of the housing in a vise. Use protective caps on jaws of vise so stub shaft does not get damaged by the vise. Position the interconnecting shaft and tripod assembly on top of the plastic retaining collar. Carefully insert each of the tripod rollers into the retaining collar, one at a time. Hold the interconnecting shaft on an angle and carefully push down on the shaft until the rollers are locked into the retaining collar on the housing.

(4) Position the boot over the boot retaining groove in the housing and clamp in place. See Boots Install.

S.S.G. Assembly

(1) Distribute 1/2 the amount of the grease provided into the housing and the remaining amount into the boot.

(2) Position the spring in the housing spring pocket with the spring cup attached to the exposed end of the spring (Fig. 12). Place a small amount of grease on the concave surface of the spring cup.

CAUTION: Care must be taken to ensure proper spring positioning. The spring must remain centered in the housing spring pocket when the tripod is installed and seated in the spring cup (Fig. 12).

(3) Slip tripod into housing and install the tripod wire retaining ring into position. Check for the ability of the retaining ring to hold the tripod in the housing.

(4) Position the boot over the boot retaining groove in the housing and clamp in place. See Boots Install.

OUTER C/V JOINT

DISASSEMBLE

(1) Remove boot clamps on boot and discard (Fig. 1).

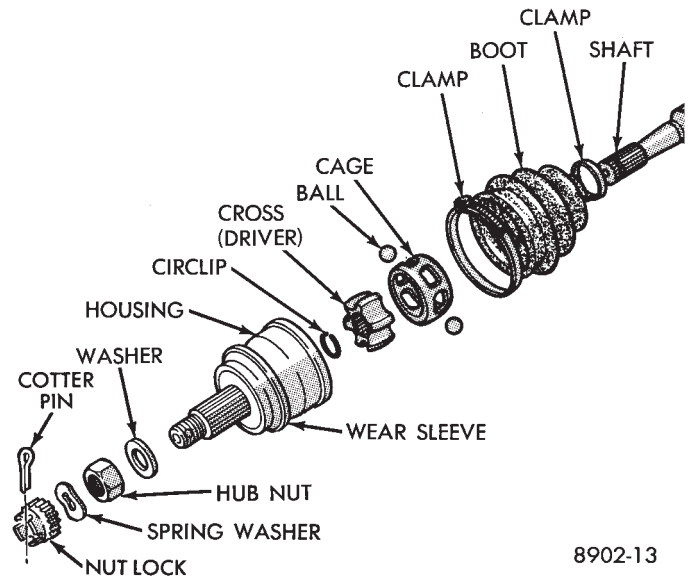

Fig. 1 Outer C/V Joint Components

(2) Wipe away grease to expose joint.
 (3) G.K.N. Remove outer C/V Joint from shaft by supporting the interconnecting shaft in a vise. Use protective caps on the jaws of the vise to prevent damage to the interconnecting shaft. Give a sharp tap to the top of housing to dislodge joint from

internal circlip installed in a groove at the outer end of the shaft (Fig. 2).

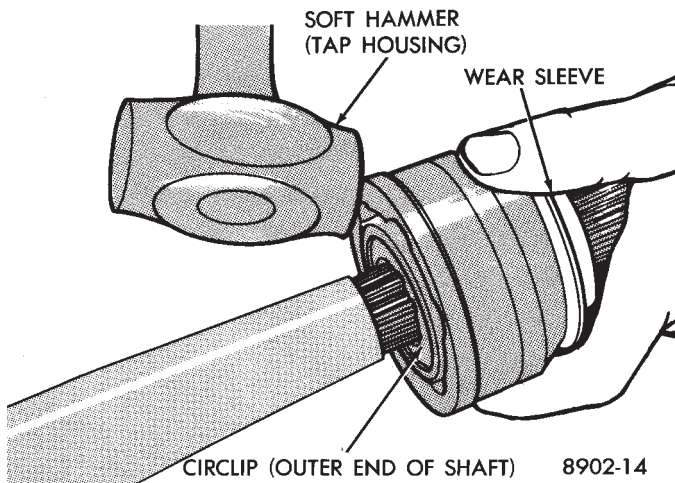

Fig. 2 Remove Joint from Shaft .

S.S.G. A single circlip located in a groove on the cross, is used to retain the cross to the shaft (Fig. 3). Loosen the damper weight bolts and slide it and the boot towards the inner joint. Expand the circlip with snap ring pliers and slide joint from shaft. Install damper weight, see Damper Weights.

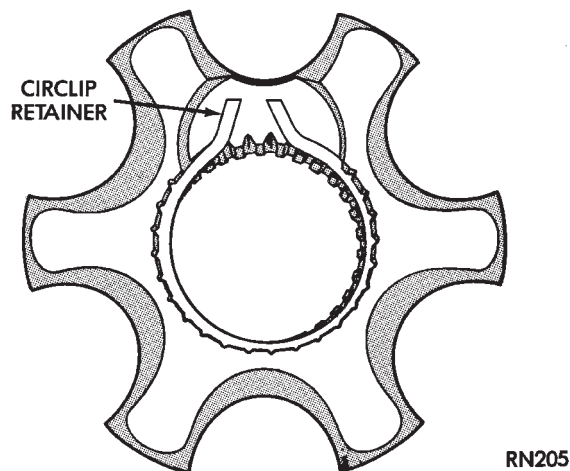

Fig. 3 Circlip Retainer in Cross S.S.G.

WEAR SLEEVE

A wear sleeve installed on the outer C/V joint housing (Fig. 1) provides a wipe surface for the hub bearing seal (installed in the steering knuckle).

(4) If bent or damaged, carefully pry wear sleeve from C/V joint machined ledge.

(5) Remove circlip from shaft groove and discard (Fig. 4). A replacement boot package will include this circlip.

(6) Unless the shaft is damaged and needs replacing, **do not remove** the heavy spacer ring from the shaft, G.K.N. only (Fig. 4).

(7) With joint separated from the interconnecting shaft proceed as follows:

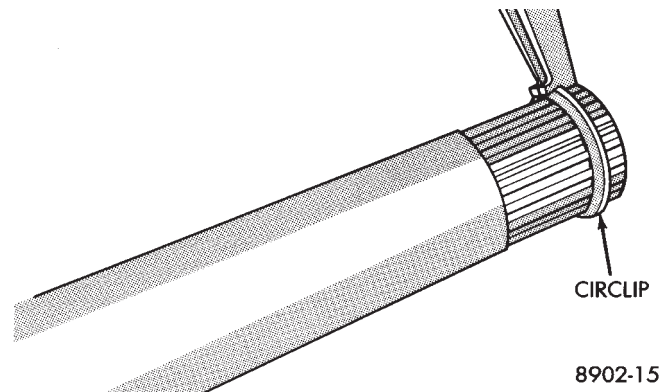

Fig. 4 Remove Circlip

- If outer C/V joint was operating satisfactorily and grease does not appear to be contaminated, just replace boot. Bypass the following disassembly procedure for the C/V joint assembly, See Boots Install.

- If outer joint is noisy or **badly** worn. Bypass the following disassembly and replace entire unit. It is also recommended that the boot be replaced. The Boot Package includes the boot, clamps, retaining ring (circlip), and lubricant. See boots install.

(8) Hold joint vertically in vise by clamping on splined shaft, using soft jaws to prevent damage.

(9) Wipe off surplus grease and mark relative position of inner cross, cage and housing with a dab of paint (Fig. 5).

(10) Press down on one side of inner race to tilt cage and remove ball from opposite side (Figs. 5 and 6). If joint is tight, use a hammer and brass drift to tap inner race. **Do not hit the cage.** Repeat this step until **all 6** balls are removed. A screwdriver may be used to pry balls loose.

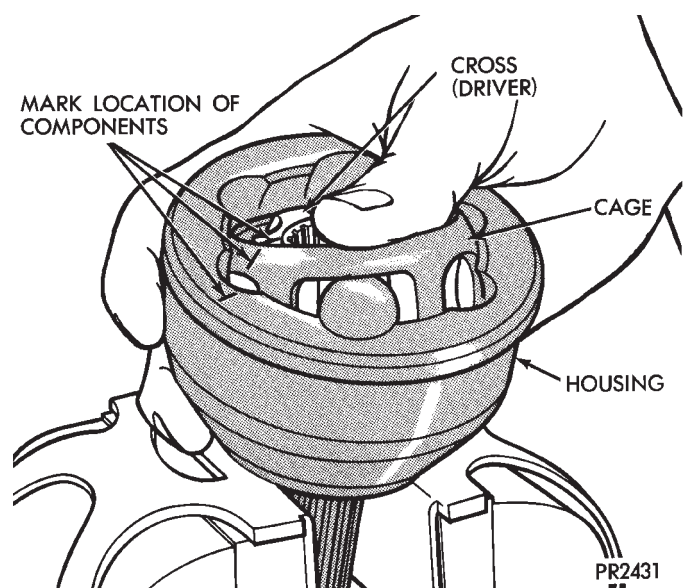

Fig. 5 Rotate Cage & Cross to Remove Balls

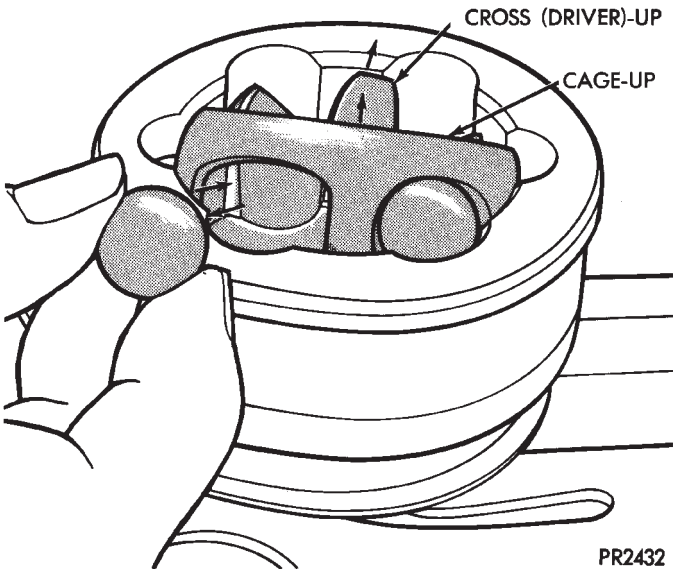

Fig. 6 Ball Released

(11) Tilt the cage and inner race assembly vertically and position two opposing cage windows in area between the ball grooves. Remove the cage and inner race assembly by pulling upward away from the housing (Fig. 7).

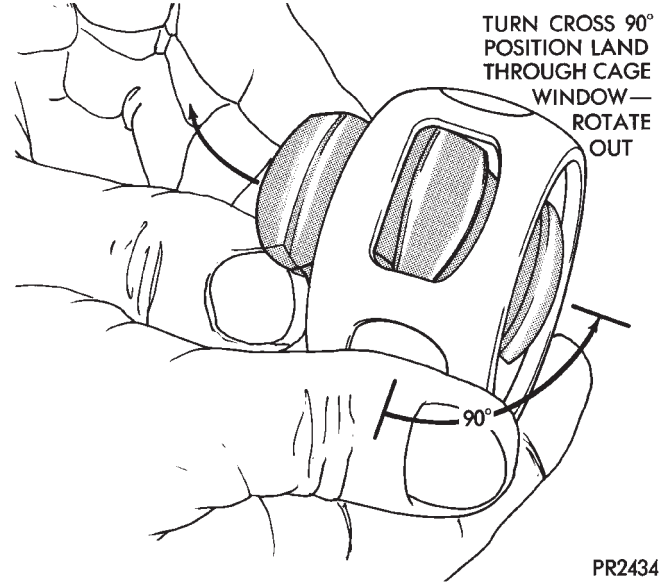

Fig. 8 Removing Cross from Cage

INSPECT

Check grease for contamination and all parts for defects as follows:

- (1) Wash all parts in suitable solvent and dry, preferably with compressed air.
- (2) Inspect housing ball races for excessive wear and scouring.
- (3) Check splined shaft and nut threads for damage.
- (4) Inspect all 6 balls for pitting, cracks, scouring and wear. Dulling of surface is normal.
- (5) Inspect cage for excessive wear on inside and outside spherical surfaces, surface ripples on cage window, cracks, and chipping.
- (6) Inspect inner race (cross) for **excessive** wear or scouring of ball races.

Any of the above defects will warrant replacing the C/V assembly as a unit.

Polished areas in races (cross and housing) and on cage spheres are normal and do not indicate need for joint replacement, unless they are suspected of causing noise and vibration.

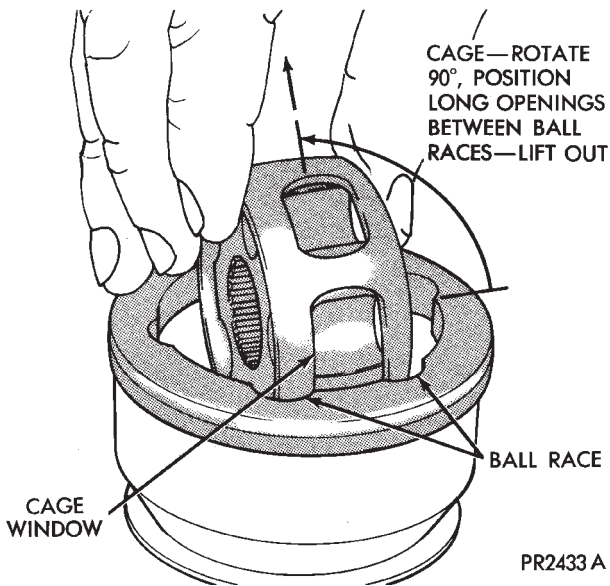

Fig. 7 Removing Cage & Cross Assembly from Housing

(12) Turn inner cross (driver) 90° to cage and align one of the race spherical lands with cage window. Raise land into cage window and remove inner race by swinging out (Fig. 8).



ASSEMBLE

If outer joint was not disassembled nor the wear sleeve damaged go to step 11.

(1) Position new wear sleeve on joint housing machined ledge (Fig. 1). Assemble Installer, Special Tool C-4698 (Tool is provided with handle and dual purpose drive head for installing wear sleeve onto C/V joint housing and (head reversed) seal into knuckle). See KNUCKLE BEARING SEAL.

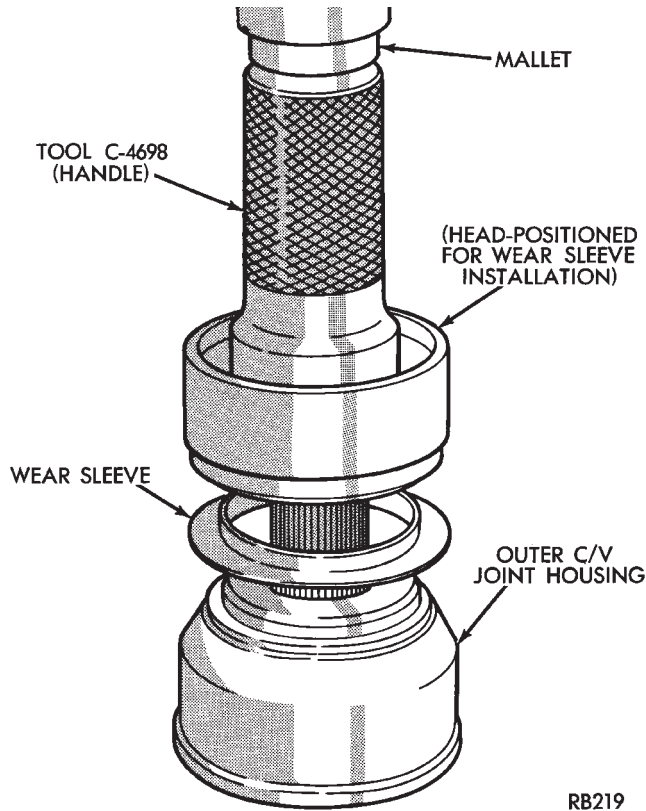

RB219

Fig. 1 Tool Set-Up for Wear Sleeve Installation

- (2) See (Fig. 1). Assemble tool and install wear sleeve.
- (3) Lightly oil all components before assembling outer joint.
- (4) Align parts according to paint markings.
- (5) Insert one of the inner race (cross) lands into cage window (Fig. 2) and feed race into cage. Pivot cross 90° to complete cage assembly (Fig. 3).
- (6) Align opposing cage windows with housing land and feed cage assembly into housing (Fig. 4). Pivot cage 90° to complete installation.

When properly assembled the large counterbore in the cross should be facing outward from the joint on G.K.N. units (Figs. 3 and 6). On the S.S.G. joint the internal circlip in the cross will be facing outward from the housing (Fig. 5).

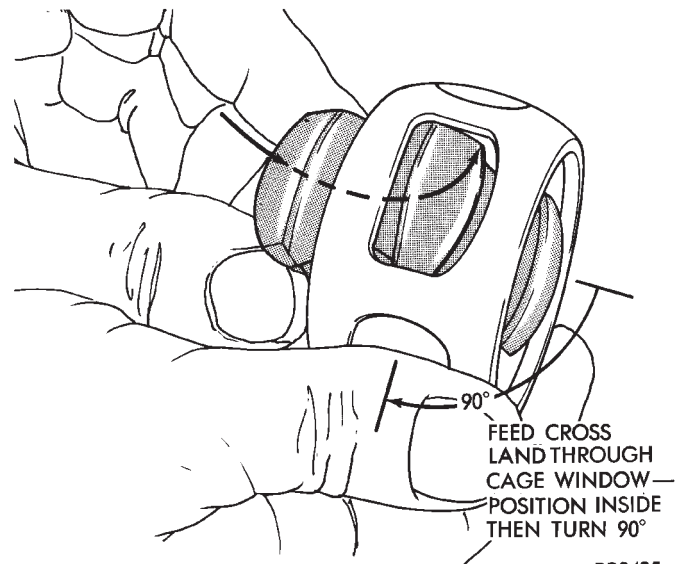

PR2435

Fig. 2 Installing Cross into Cage

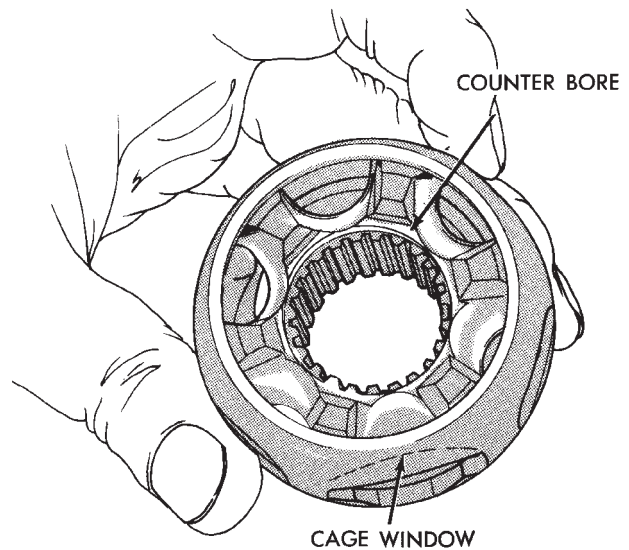

PR2436 A

Fig. 3 Cage & Cross Assembled G.K.N.

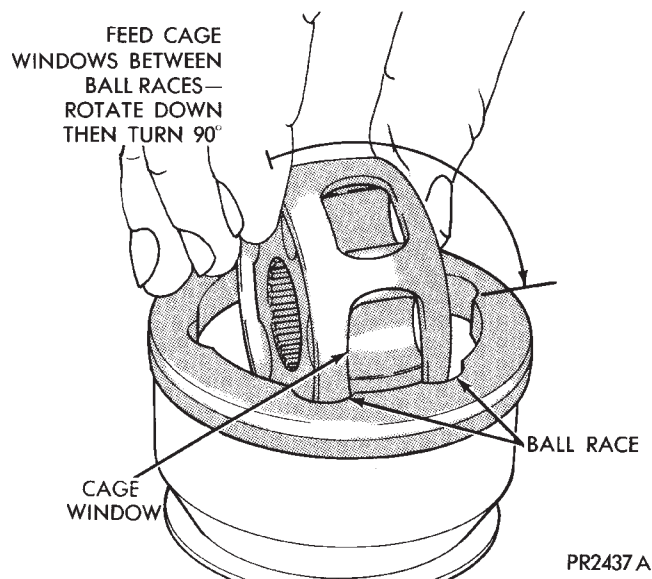

PR2437 A

Fig. 4 Installing Cage & Cross into Housing

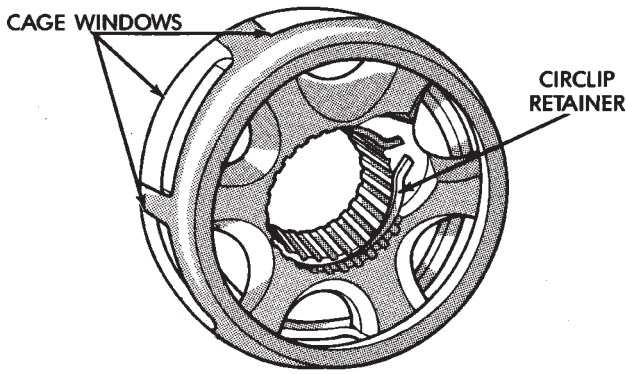

Fig. 5 Cage & Cross Assembled S.S.G.

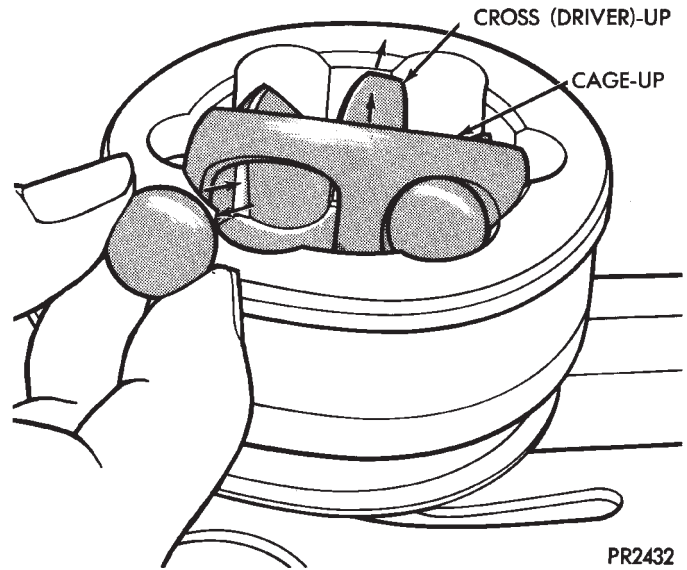

Fig. 7 Inserting Balls into Raceway

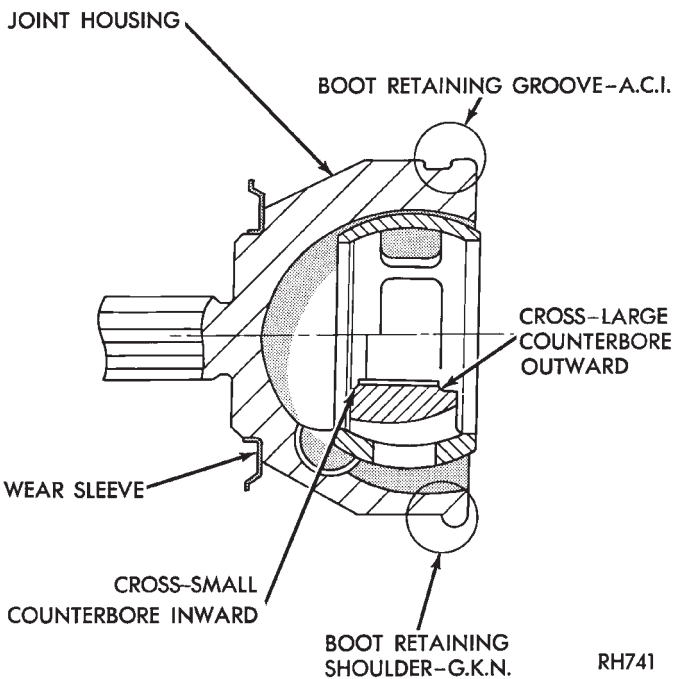

Fig. 6 Cage & Cross Installed in Housing G.K.N.

(7) Apply lubricant to ball races from packet provided in boot kit and distribute equally between all sides of ball grooves. One packet is sufficient to lubricate the joint.

(8) Insert balls into raceway by tilting cage and inner race assembly (Fig. 7).

(9) Fasten boot to shaft. See **Boots Install**.

(10) On G.K.N. units insert the new circlip, provided with kit in shaft groove. **Do not over expand or twist** circlip during assembly (Fig. 8). The S.S.G. unit has a reusable circlip retainer that is an integral part of driver assembly.

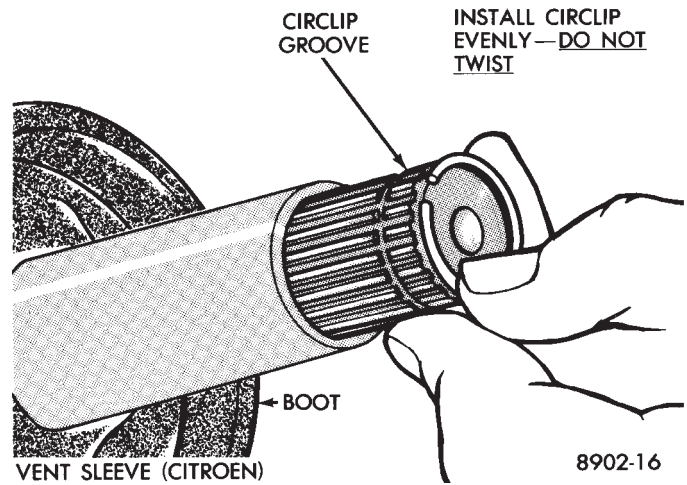

Fig. 8 Installing New Circlip

(11) Position outer joint on splined end with hub nut on stub shaft. Engage splines, and tap sharply with mallet (Fig. 9).

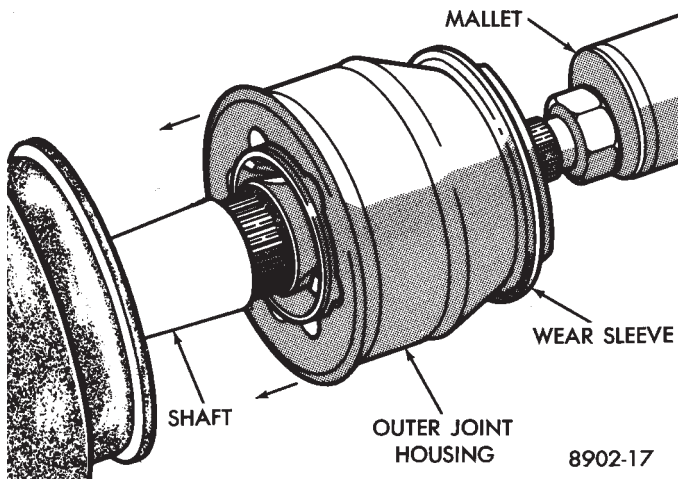

Fig. 9 Position Joint onto Shaft Splines

(12) Check that circlip is properly seated by attempting to pull joint from the shaft.

(13) Locate large end of boot over joint housing checking that boot is not twisted.

(14) Fasten boot to housing. See **Boots Install**.

C/V JOINT BOOTS

HANDLING AND CLEANING

It is vitally important during **any** service procedures requiring boot handling. That care be taken not to puncture or tear the boot by over tightening clamps, misuse of tool(s) or pinching the boot. Pinching can occur by rotating the C/V joints (especially the tripod) beyond normal working angles.

The driveshaft boots are not compatible with oil, gasoline, or cleaning solvents. Care must be taken that boots never come in contact with any of these liquids. **The only acceptable cleaning agent for drive-shaft boots is soap and water. After washing, boot must be thoroughly rinsed and dried before re-using.**

BOOTS INSPECT

Noticeable amounts of grease on areas adjacent to and on the exterior of the C/V joint boot. Is the first indication that a boot is punctured, torn or that a clamp has loosened. When a C/V joint is removed for service. The boot should be properly cleaned and inspected for cracks, tears and scuffed areas on interior surfaces. If any of these conditions exist, boot replacement is recommended.

BOOTS INSTALL

THE HARD PLASTIC BOOTS REQUIRE APPROXIMATELY **100** TIMES THE CLAMPING FORCE OF THE RUBBER BOOT. THE CLAMPS USED ON THE RUBBER BOOTS DO NOT HAVE THE TYPE OF

LOAD CAPACITY REQUIRED. TO SEAL THE HARD PLASTIC BOOTS AND SHOULD NOT BE USED FOR THIS PURPOSE.

Rubber boots appear only on the inner joints of certain driveshafts.

Rubber boots must be serviced with the strap and buckle clamp. Use the Clamp Installer, Special Tool C-4653. Proceed with the boot installation as follows:

(1) Slide the small end of the boot over the shaft. Position the boot to the edge of the locating mark or groove, whichever is appropriate (Fig. 1).

(2) Install the C/V joint. See Inner or Outer C/V

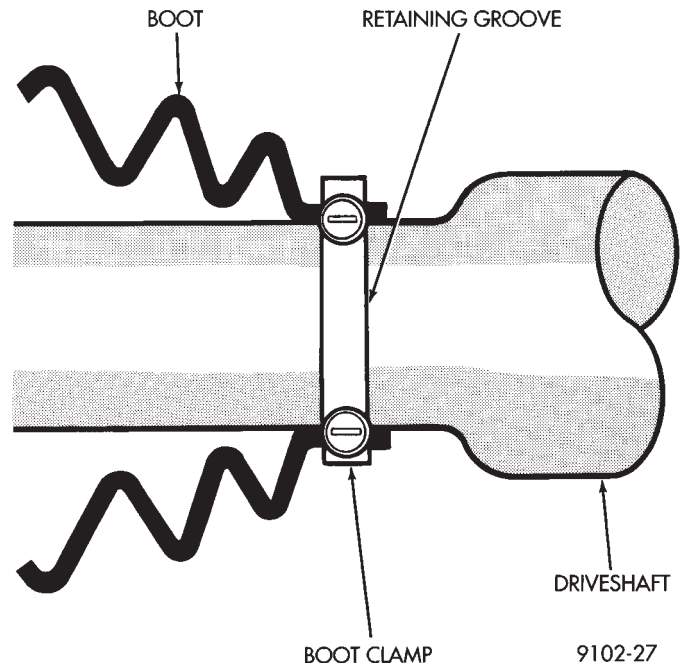

Fig. 1 C/V Joint Boot Positioning G.K.N.

Joint Assemble.

(3) Slide the large diameter of the boot into the locating groove on the C/V Joint Housing.

(4) Wrap binding strap around boot **twice**, PLUS 63 mm (2-1/2 inches) (Fig. 2).

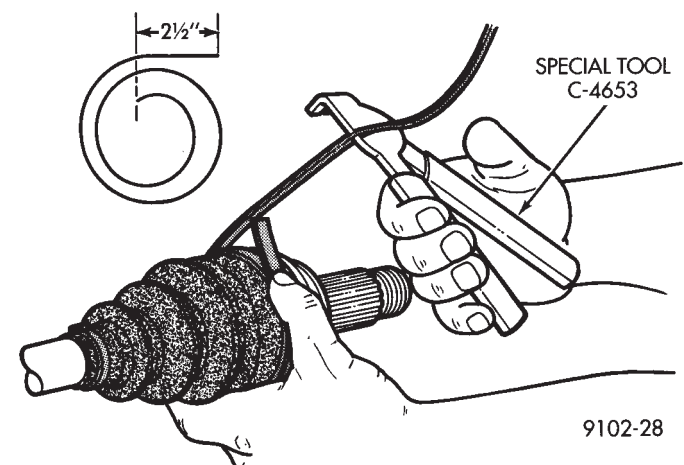

Fig. 2 Measure & Cut Binding Strap

(5) Pass the strap through the buckle and fold it back about 29 mm (1-1/8 inches) on the inside of the buckle (Fig. 3).

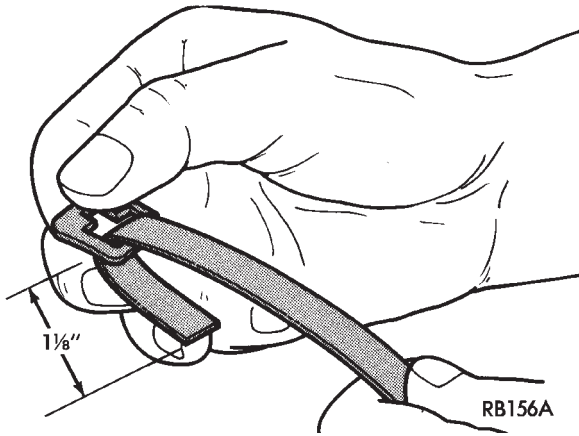

Fig. 3 Install Buckle on Strap

(6) Put the strap around the boot with the eye of the buckle toward you (Fig. 4). Wrap the strip around the boot once and pass it through the buckle, then wrap it around a second time also passing it through the buckle.

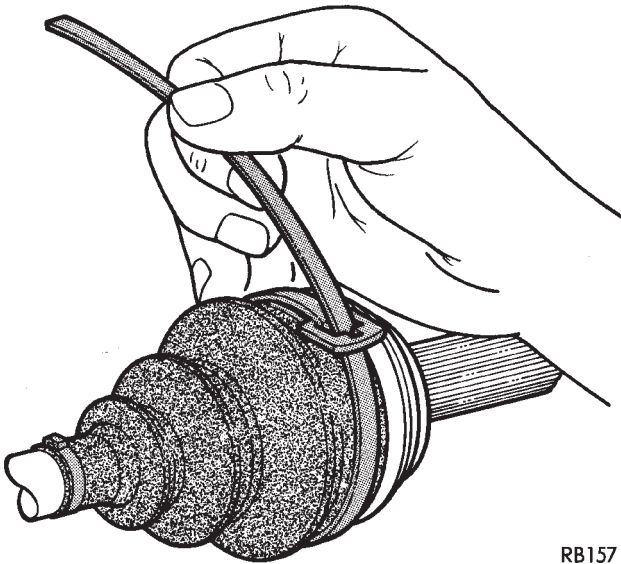

Fig. 4 Wrap Strap (through Buckle Eye) Twice

(7) Fold the strip back slightly to prevent it from slipping backwards (Fig. 5).

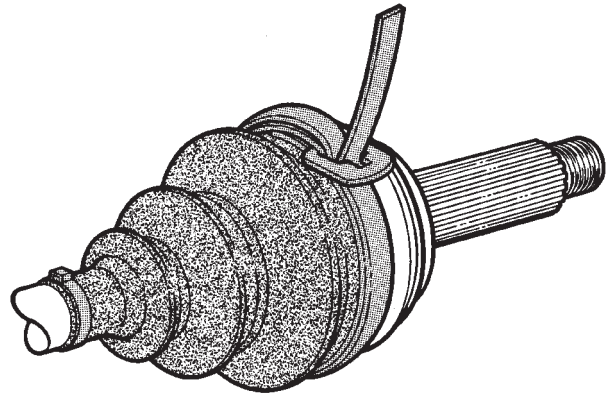

Fig. 5 Fold Strap Lightly to Keep Position

(8) Open the tool all the way and place strip in narrow slot approximately 13 mm (1/2 inch) from buckle (Fig. 6).

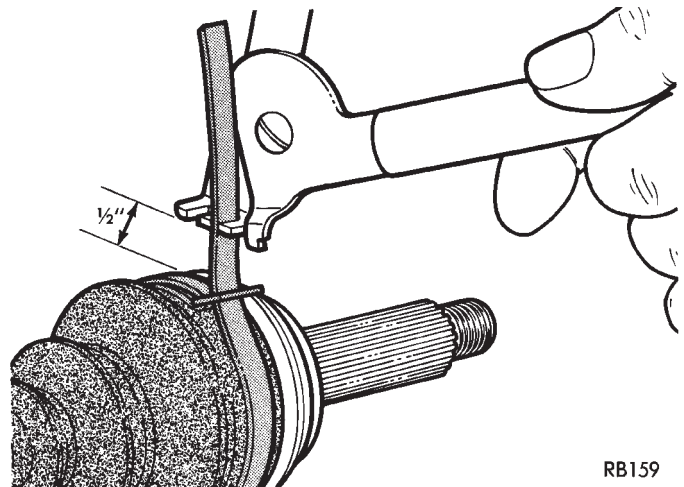

Fig. 6 Open Tool, Position Strap in Narrow Slot 1/2 Inch from Buckle

(9) Hold the binding strip with the left hand and push the Tool forward and slightly upward. Then fit the hook of the Tool into the eye of the buckle (Fig. 7).

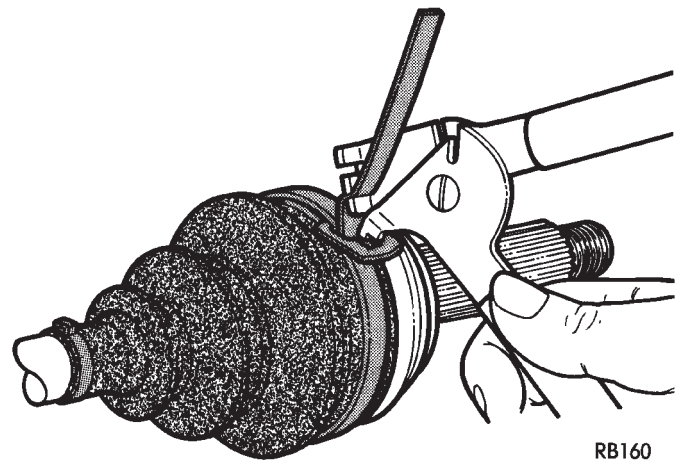
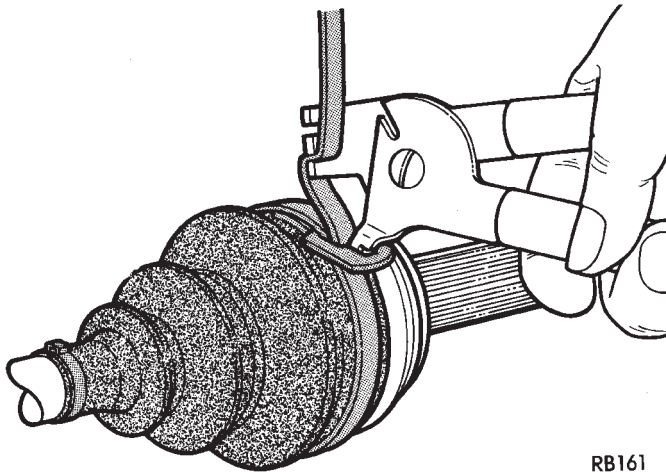

Fig. 7 Push Tool Forward & Fit into Buckle Eye

(10) Tighten the strip by closing the tool handles (Fig. 8). Then rotate the tool (handles) downward while slowly releasing the pressure on the tool handles. Allow the tool (handles) to open progressively. Then open the tool entirely and remove them sideways.

(11) If the strap is not tight enough, engage the tool



RB161

Fig. 8 Tighten Strap

a second or even a third time, always about 13 mm (1/2 inch) from the buckle (Fig. 9). When tightening always be careful to see that the strap slides in a straight line and without resistance in the buckle, that is without making a fold. An effective grip will be obtained only by following the above instructions.

(12) Fig. 10 shows WHAT NOT TO DO, NEVER fold the strap back or bring the tool down while tightening, this action will break the strap.

(13) Fig. 11 shows how to pull the tool down while releasing the pressure on the tool handle.

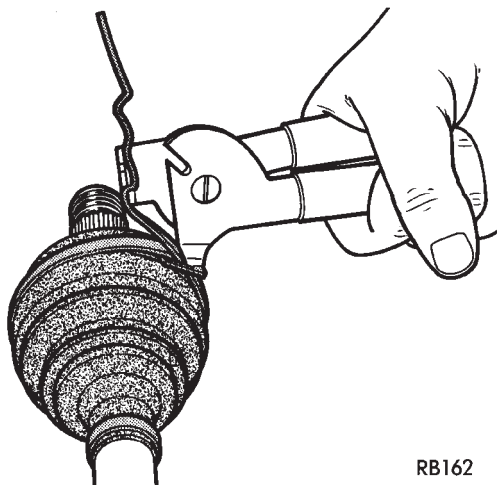

RB162

Fig. 9 Tighten Strap (if Required)

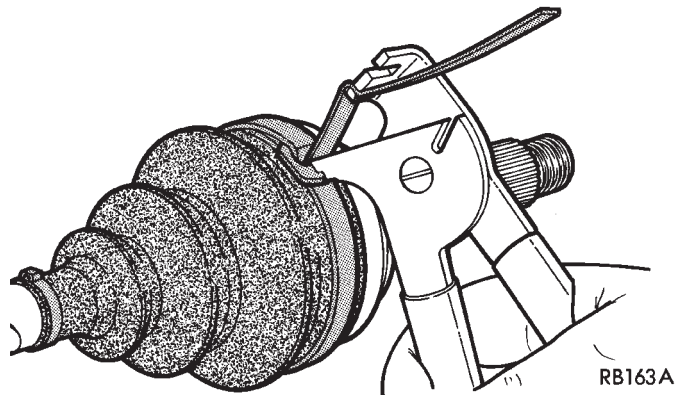

RB163A

Fig. 10 What Not to Do

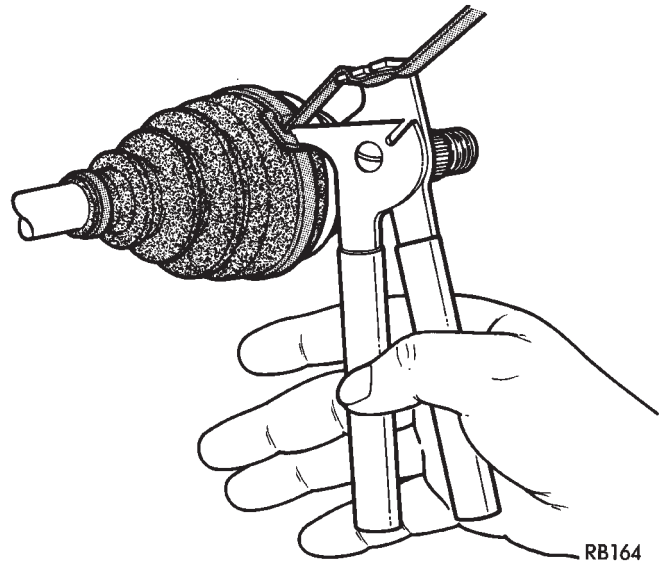

RB164

Fig. 11 Correct Tightening Procedure

(14) If the strip is tight enough. Remove the tool sideways and cut off the strap 3 mm (1/8 inch), so that it does not overlap the edge of the buckle. Complete job by folding the strip back neatly (Fig. 12).

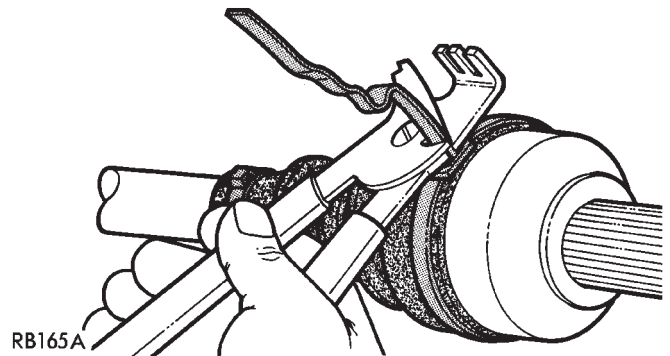

RB165A

Fig. 12 Cut Strap 1/8 Inch from Buckle

(15) Fig. 13 shows the finished binding strap type clamp in position, correctly fitted and unable to come loose.

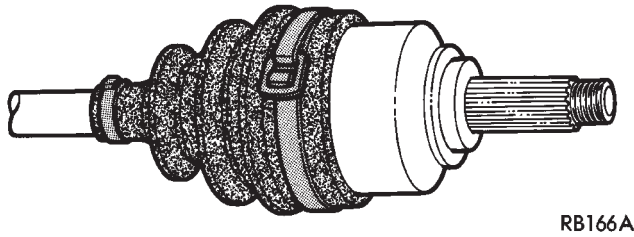

Fig. 13 Correctly Installed Clamp

(16) After attaching the boot to the shaft. Install the inner or outer C/V joint following procedures under Inner C/V Joint Assemble or Outer C/V Joint Assemble.

(17) Slip the large end of the boot on the housing and align it in the boot groove.

(18) Repeat steps 2 - 13 for boot clamping.

S.S.G. C/V joints use two different type boots, one is made of plastic and the other of rubber. The plastic boot requires a heavy duty clamp and Installer, Special Tool C-4975. The soft boot requires a clamp with round edges that prevents the clamp from cutting the boot. Proceed with boot installation as follows.

The hard plastic boots used on the G.K.N. C/V Joints. Also use this procedure for installation of the boot clamp to C/V Joint.

LEFT INNER, LEFT AND RIGHT OUTER C/V JOINT WITH PLASTIC BOOTS

- (1) Slide small clamp onto shaft.
- (2) Position small end of boot over interconnecting shaft with lip of boot in third groove, towards center of interconnecting shaft (Fig. 14).
- (3) Position boot clamp evenly over boot. Place clamp installer Tool C-4975 over bridge of clamp and tighten the nut until the jaws of the tool are closed completely, face to face (Fig. 15).

(4) After attaching the boot to the shaft. Install the C/V joint following the procedure outlined under **Inner C/V Joint Assemble** or **Outer C/V Joint Assemble**.

(5) Position the large end of boot on housing and install clamp, crimp bridge of clamp with Crimper, Special Tool C-4975.

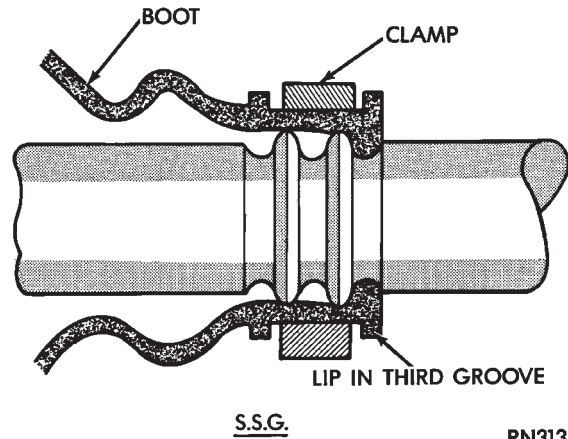

Fig. 14 Boot and Clamp Positioning S.S.G.

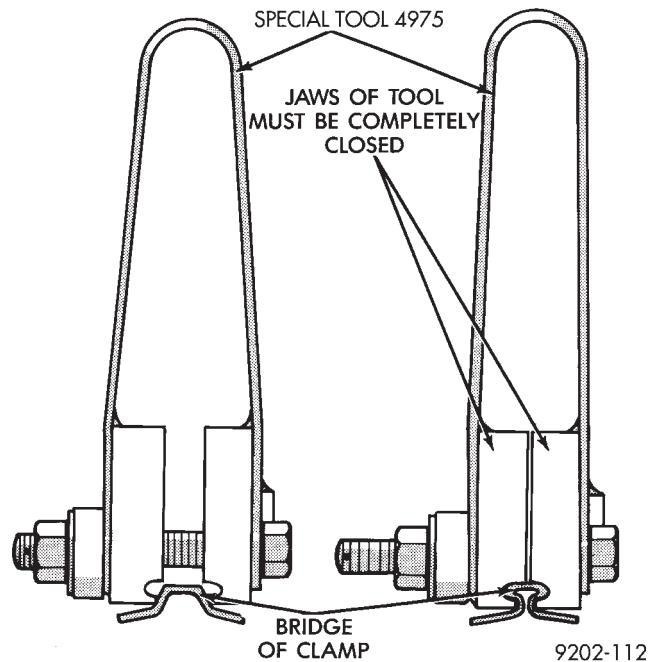

Fig. 15 Closing Clamp Bridge

CAUTION: Use only the clamps provided in the boot package for this application, otherwise damage to the boot or C/V joint may occur.

RIGHT INNER C/V JOINT WITH RUBBER BOOT

- (1) Slide small end boot clamp onto interconnecting shaft.



(2) Install boot onto interconnecting shaft, position boot on the flat between the locating shoulders (Fig. 16).

(3) Position clamp on boot and crimp bridge of clamp with Crimper Special Tool C-4124.

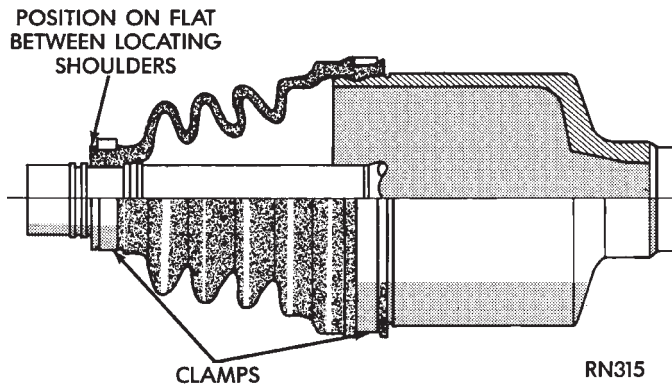

Fig. 16 Right Inner C/V Joint S.S.G.

(4) Install the C/V Joint following the procedure outlined under **Inner C/V Joint Assemble**.

(5) Position the large end of boot on housing and install clamp, crimp bridge of clamp with Crimper, Special Tool C-4124.

CAUTION: During any service procedures where knuckle and driveshaft are separated, thoroughly clean seal and wear sleeve with suitable solvent and lubricate **BOTH** components at assembly. Do not allow solvent to contact boot.

Lubricate wear sleeve (and seal) with Mopar® Multi-Purpose Lubricant, or equivalent, as follows:

Wear Sleeve: Apply a full circumference 6 mm (1/4 inch) bead of lubricant to seal contact area. See (Fig. 11), Driveshaft Assemblies Install.

Seal: Fill lip to housing cavity (full circumference) and wet seal lip with lubricant.

S.S.G INNER C/V JOINT LARGE CLAMP (MANUAL TRANS ONLY)

(1) Install small clamp and inner C/V joint housing according to the procedures outlined in this manual.

(2) Position the boot over the outer C/V joint.

(3) Slide the large band clamp over the boot and position it evenly in the groove on the inner C/V joint boot. (Fig. 1).

(4) Use Clamp Locking Tool Snap-On YA3050 or equivalent shown in (Fig. 2) to install the clamp on the boot.

(5) Place the prongs of the clamp locking tool in the holes on the clamp and squeeze together until the two ends meet (Fig. 2).

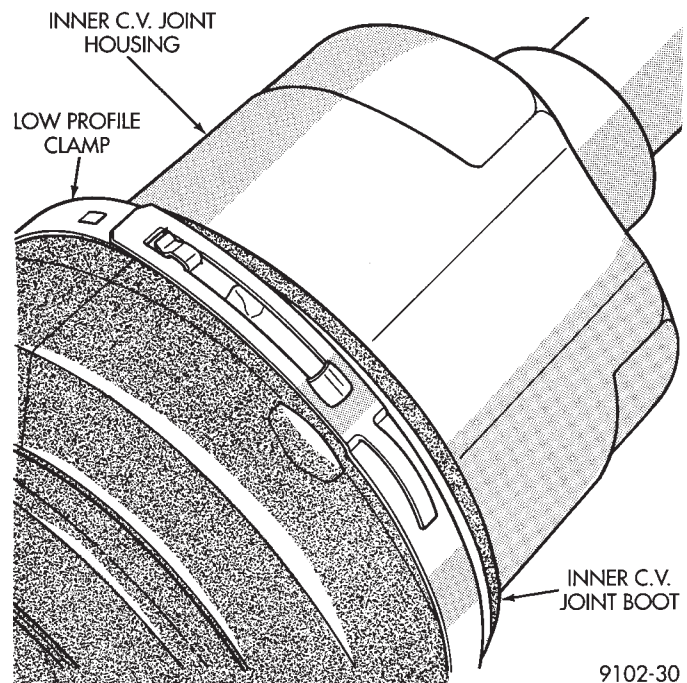

Fig. 1 Boot Clamp Installed

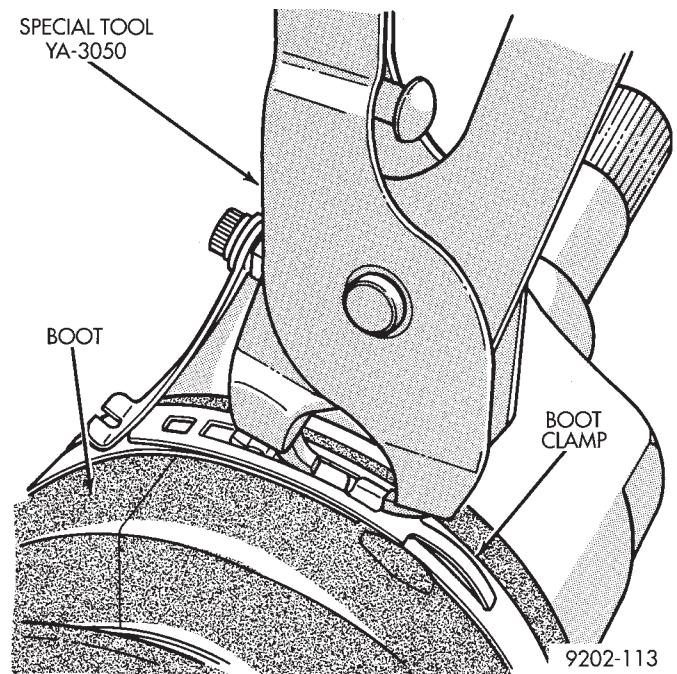

Fig. 2 Locking Boot Clamp

DAMPER WEIGHTS

Damper weights are used on the left driveshaft assemblies of all front wheel drive vehicles (Fig. 1). These weights are attached to the interconnecting shaft and are available as a separate service part. They should be removed from the driveshaft assembly during driveshaft positioning specification procedures. When the weights are attached between the locating shoulders, tighten the fasteners to 28 N•m (21 ft. lbs.) torque.

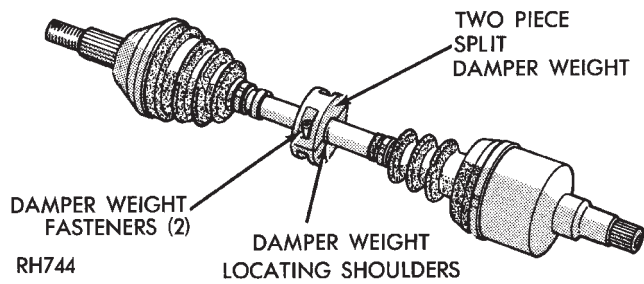

Fig. 1 Left Driveshaft with Damper Weight

DRIVESHAFT POSITIONING SPECIFICATIONS

Front wheel drive vehicles have engine mounts with slotted holes allowing for side to side positioning of the engine. If the vertical bolts on the right or left upper engine mount have been loosened (e.g., engine removal and installation) for any reason, or if the vehicle has experienced front structural damage, driveshaft lengths must be checked and corrected, if required. A shorter than required driveshaft length can result in objectionable noise. A longer than required driveshaft length may result in potential damage.

Use of the following procedure will ensure satisfactory driveshaft engagement under all normal vehicle operating conditions.

(1) The vehicle must be completely assembled. Front wheels must be properly aligned and in the straight ahead position. The vehicle must be in a position so that the full weight of the body is distributed to all four tires. A platform hoist, or front end alignment rack, is recommended.

(2) Using a tape measure or other suitable measuring device. Measure the direct distance from the inner edge of the outboard boot to the inner edge of the inboard boot on both driveshafts. This measurement must be taken at the bottom (six o'clock position) of the driveshafts (Fig. 1).

Note that the required dimensions vary with driveshaft manufacturer.

(3) If the lengths of both shafts are within the range specified, on the chart below, no further action is required.

If either the left or right drive shaft length is not within the specified range. Refer to Engine, Group 09, Engine Removal and Installation to properly position the engine according to the driveshaft lengths specified.

(4) If proper driveshaft lengths cannot be achieved within the travel limits available in the slotted engine mounts. Check for any condition that could effect the side to side position of the measurement locations (e.g., engine support brackets, siderail alignment, etc.).

(5) After ensuring proper driveshaft lengths the transmission shift linkage must be adjusted to ensure proper operation. Refer to Transaxle, Group 21.

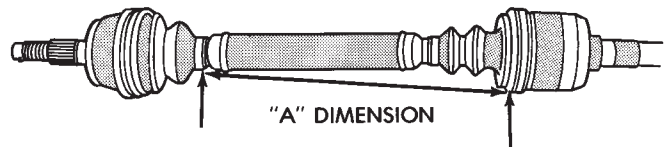

9102-61

Fig. 1 Driveshaft Positioning

DRIVESHAFT DIMENSIONS INSTALLED

ENGINE	DRIVESHAFT IDENTIFICATION Type	Side	"A" DIMENSION	
			mm	inch
3.0L/3.3L 4x2-AUTO	GKN	Right Left	476-486 184-194	18.7-19.1 7.2-7.6
3.3L 4x4-AUTO	GKN	Right Left	292-302 184-194	11.5-11.9 7.2-7.6
2.5L MANUAL	GKN Saginaw	Right Left	476-486 213-223	18.7-19.1 8.4-8.8
2.5L AUTOMATIC	GKN	Right Left	480-490 185-195	18.9-19.3 7.3-7.7

9202-114

SPECIFICATIONS

TORQUE SPECIFICATIONS

DESCRIPTION	TORQUE
Wheel Stud Lug Nut	110-135 N·m (85-115 ft. lbs.)
Strut Damper To Steering Knuckle Bolts	*100 N·m (75 ft. lbs.)
Lower Control Arm Pivot Nut And Bolt	129 N·m (95 ft. lbs.)
Sway Bar Cushion Attachment Bolts	70 N·m (50 ft. lbs.)
Sway Bar End Bushing Bracket Bolts	70 N·m (50 ft. lbs.)
Ball Joint Stud To Steering Knuckle Bolt And Nut	136 N·m (100 ft. lbs.)
Strut Rod To Strut Mount Nut	75 N·m (55 ft. lbs.)
Strut Mount To Shock Tower Attaching Nut	28 N·m (250 in. lbs.)
Crossmember To Frame Rail Forward Bolt	122 N·m (90 ft. lbs.)
Crossmember To Frame Rail Mounting Stud	54 N·m (40 ft. lbs.)
Crossmember Nut To Stud	122 N·m (90 ft. lbs.)
Crossmember To Steering Gear Mounting Bridge Fasteners	70 N·m (50 ft. lbs.)

*Plus ¼ (90°) Turn

9202-131

ALIGNMENT SPECIFICATIONS AT CURB HEIGHT

FRONT WHEEL ALIGNMENT	ACCEPTABLE ALIGNMENT RANGE AT CURB HEIGHT	PREFERRED SETTING
CAMBER . . . All Models	-0.2° TO +.80°	+0.3°
TOE . . . All Models Specified in Degrees	7/32" In to 1/8" Out .4° In to 2° Out	1/16" In ± 1/16" 0.1° In ± 1°
CASTER *	REFERENCE ANGLE	
All Models Van/Wagon *Side To Side Caster Should Not Exceed 1.5 Degrees	1.3°	
REAR WHEEL ALIGNMENT	ACCEPTABLE ALIGNMENT RANGE AT CURB HEIGHT	PREFERRED SETTING
CAMBER . . . All Models	-.8° To + .4°	-0.2°
TOE* . . All Models Specified in Inches Specified in Degrees3" Out to .3" In .6° Out to .6° In	0.0" 0.0°
Thrust Angle	-.40° to +.40°	-.40° to +.40°
**TOE OUT When Backed On Alignment Rack is TOE IN When Driving.		

