

TRANSAXLE

CONTENTS

	page		page
A-523 MANUAL TRANSAXLE	1	4-SPEED ELECTRONIC AUTOMATIC TRANSAXLE	82
ALL WHEEL DRIVE POWER TRANSFER UNIT (P.T.U.)	141	SPECIFICATIONS	197
4-SPEED ELECTRONIC TRANSAXLE HYDRAULIC SCHEMATICS	184	THREE SPEED TORQUEFLITE AUTOMATIC TRANSAXLE	32
4-SPEED ELECTRONIC TRANSAXLE ON-BOARD DIAGNOSTICS	157	THREE SPEED TRANSAXLE HYDRAULIC SCHEMATICS	176

A-523 MANUAL TRANSAXLE INDEX

	page		page
Bearing Adjustment Procedure	29	In-Car Transaxle Disassemble/Assemble	4
Differential Bearing Preload Adjustment	30	Out of Car Transaxle—Disassemble and Assemble ..	5
Gearshift Linkage Adjustment (Cable Operated) ...	2	Subassembly-Recondition	15
General Information	1	Transaxle Removal and Installation	4
Identification	1		

GENERAL INFORMATION

Safety goggles should be worn at all times when working on these transaxles. All manual transaxles use SAE 5W-30 engine oil, meeting SG and/or SG-CC qualifications, as the lubricant to reduce wear.

The Chrysler 5-speed manual transaxles combine gear reduction, ratio selection, and differential functions in one unit. It is housed in a die-cast aluminum case (Fig. 1).

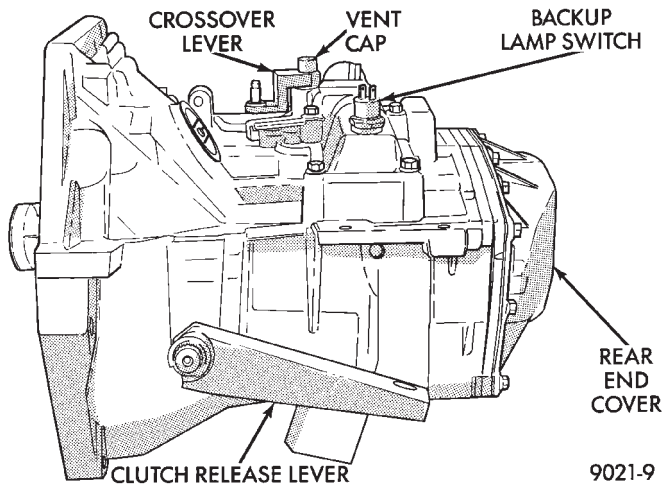

Fig. 1 External Transaxle Components

All shift forks are cast iron. **Do not interchange 1-2 or 5th shift fork pads with the 3-4 shift fork pads.** All synchronizers use a **winged strut** design that prevents the struts from popping out of position.

If any synchronizer is to be disassembled, mark all parts so that they will be reassembled in the same position.

CAUTION: 1-2 synchronizer assembly components must NOT be interchanged with any other synchronizer assembly, or with previous model years transaxles; they will NOT function correctly.

To reduce wear, the manual transaxle uses SAE 5W-30 engine oil as the lubricant.

Gear ratios for the A-523 are as follows: 1st-3.31, 2nd-2.06, 3rd-1.36, 4th-0.97, 5th-0.71, Reverse-3.14. Final drive ratio is 3.77.

IDENTIFICATION

The transaxle model, assembly number, build date, and final-drive ratio are stamped on a tag that is attached to the top of the transaxle (Fig. 2).

Certain transaxle assemblies use high-strength Steel in various gears to provide adequate life in heavy-duty applications. Therefore, it is imperative that the correct transaxle assembly number is used when ordering service parts. Also, be sure

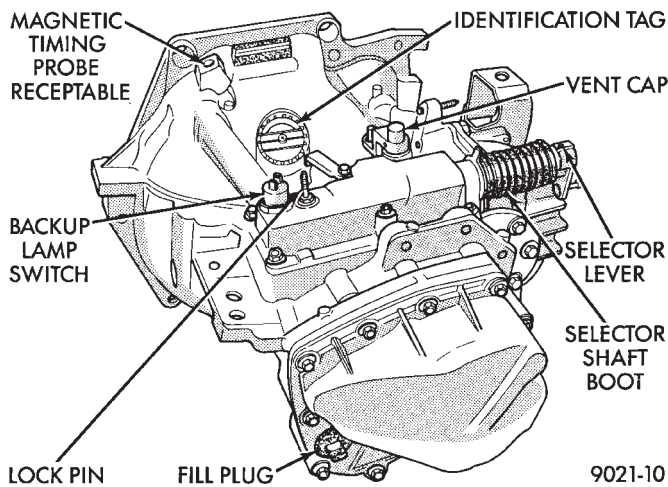

Fig. 2 A-523 Transaxle Identification

to reinstall this tag whenever it is removed, so the information is available for future service.

CAUTION:All gears and shafts must not be interchanged with previous model years; they will not function correctly.

The last eight digits of the Vehicle Identification Number (V.I.N.) are stamped on a raised boss on top of the clutch housing area.

GEARSHIFT LINKAGE ADJUSTMENT (CABLE OPERATED)

Before replacing the gearshift selector cable or crossover cable for a **hard-shifting** complaint, disconnect both cables at the transaxle (Fig. 3). Then, from the driver's seat, manually operate the gearshift lever through all gear ranges. If the gearshift lever moves smoothly, the cable(s) should NOT be replaced.

(1) Working over the left front fender, remove the lock pin from the transaxle gearshift (selector shaft) housing (Fig. 4).

(2) Reverse the lock pin (so long end is down) and insert lock pin into same threaded hole. A hole in the selector shaft will align with the lock pin, allowing the lock pin to be screwed into the housing. This operation locks the selector shaft in the 3-4 neutral position.

(3) Remove or install gearshift knob (Fig. 5 or 6).

(4) Remove or install boot (Fig. 7).

(5) Remove or install selector and crossover cables (Fig. 8 or 9).

Cable attachment clips must be installed from the side. Install cable fittings to shifter pins by pushing with thumb.

CAUTION: Be sure crossover bellcrank does NOT move when tightening adjusting screw (Fig. 10).

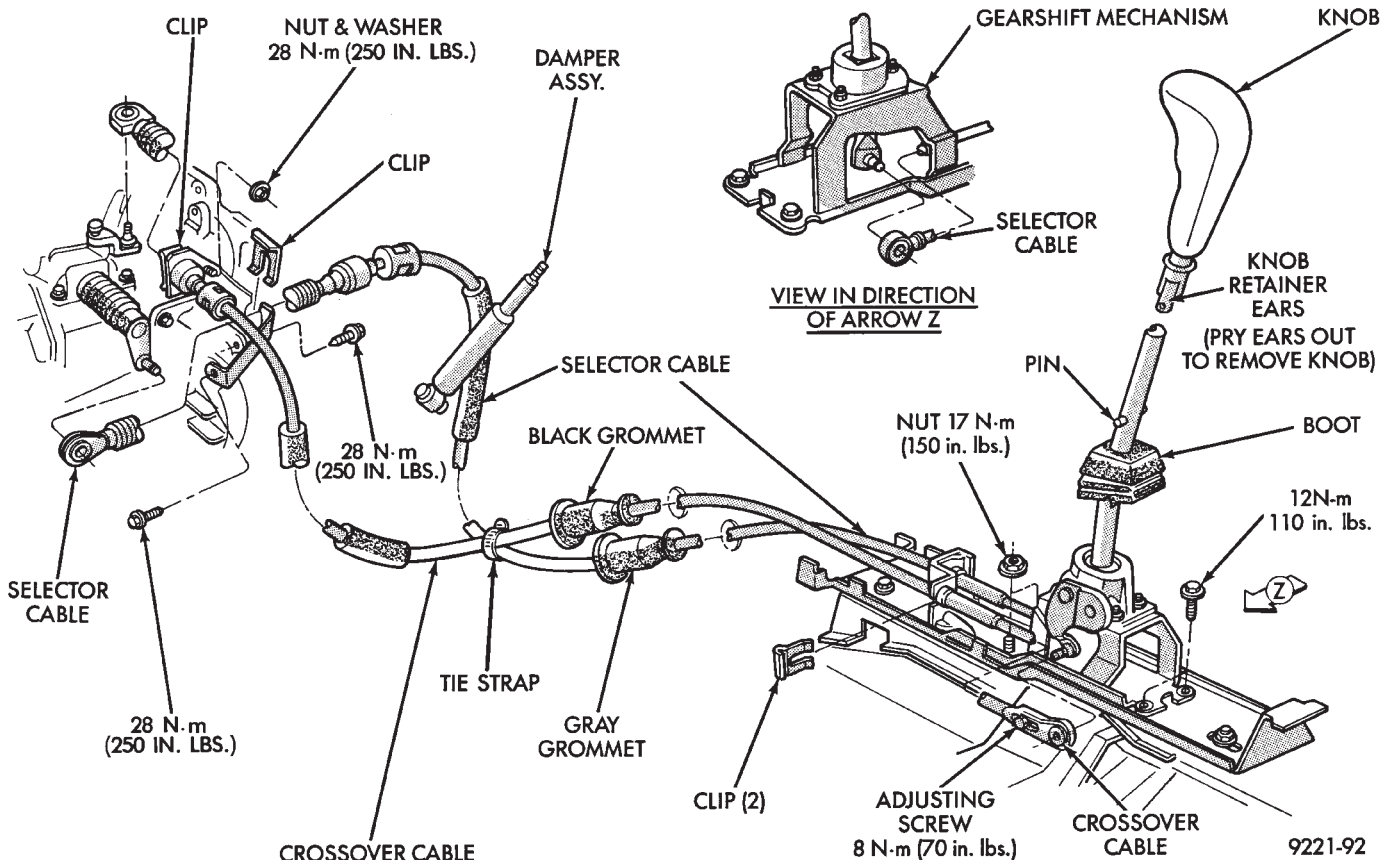

Fig. 3 Gearshift Mechanism

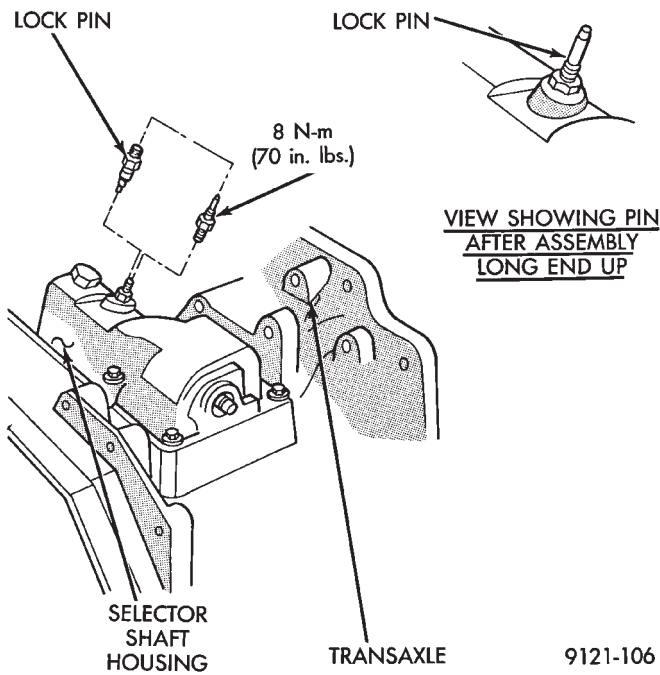

Fig. 4 Manual Transaxle Pinned in the Neutral Position to Adjust Gearshift

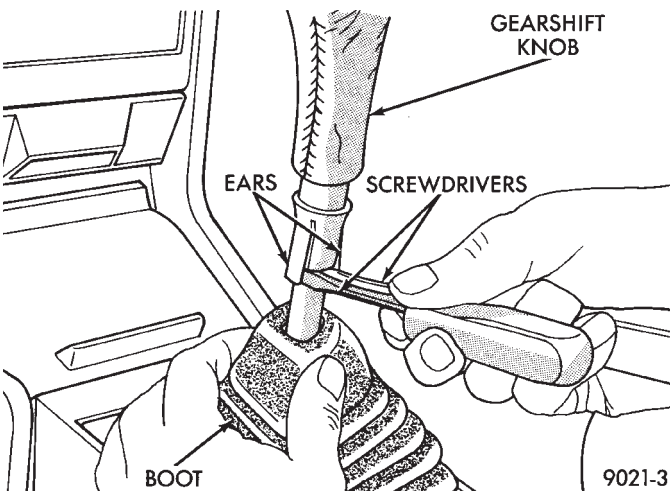

Fig. 5 Remove Gearshift Knob

CAUTION: Proper torque to the crossover cable adjusting screw is very important (Fig. 10).

(6) Remove lock pin from gearshift housing and reinstall lock pin (so long end is up) in gear shift housing (Fig. 4). Tighten lock pin to 8 N•m (70 in. lbs.).

(7) Check for shift into first and reverse. Check for blockout into reverse.

(8) Gearshift mechanism and cables are now functioning properly.

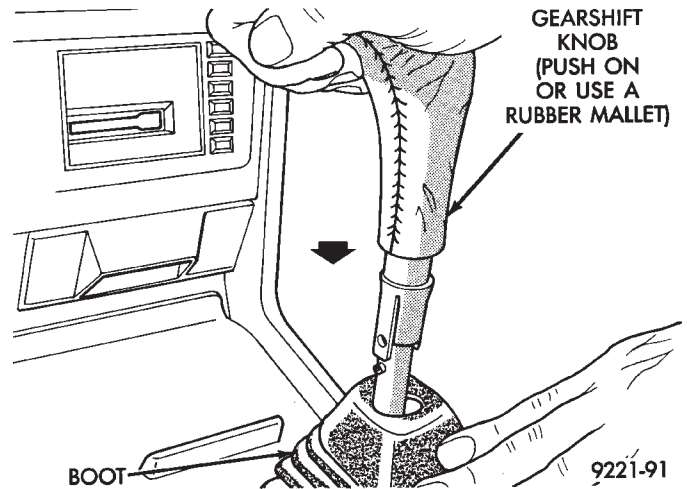

Fig. 6 Install Gearshift Knob

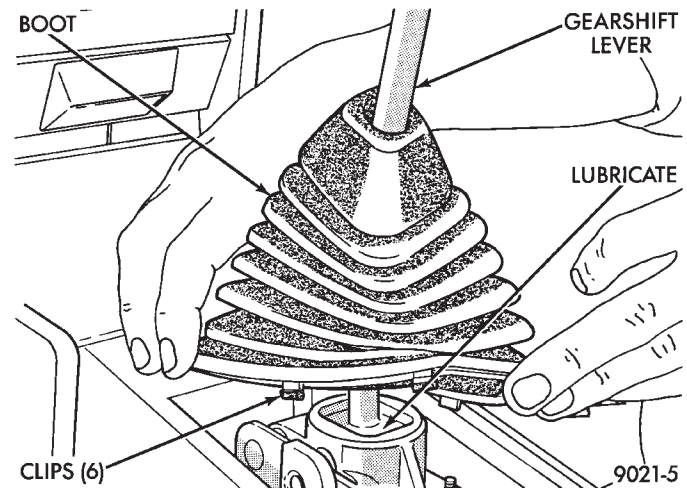

Fig. 7 Remove or Install Boot

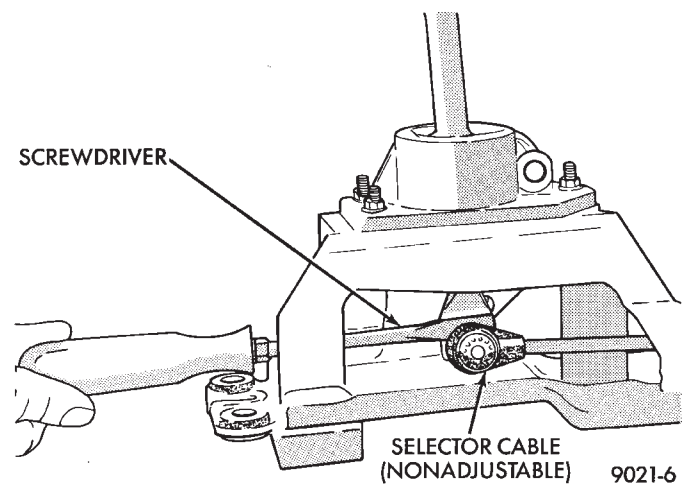

Fig. 8 Remove Cables

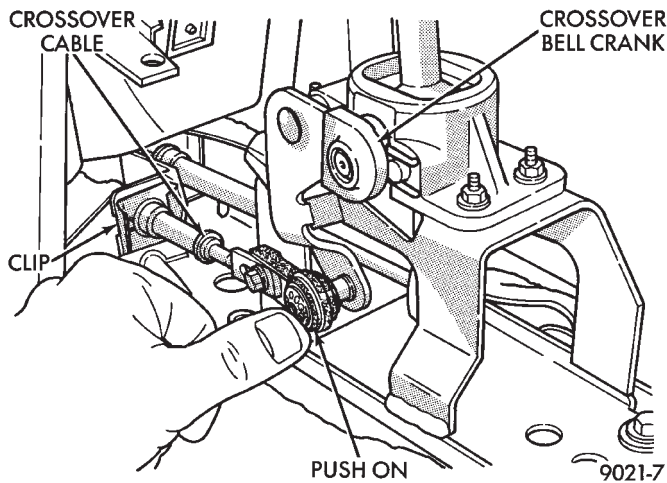

Fig. 9 Install Cables

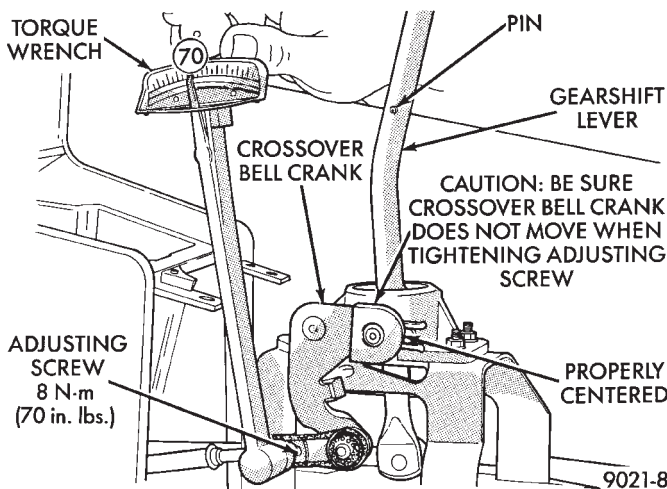

Fig. 10 Adjusting Crossover Cable

IN-CAR TRANSAXLE DISASSEMBLE/ASSEMBLE

The following items can be serviced without removing the transaxle:

- Gear shift housing
- Synchronizers
- Intermediate shaft speed gears
- Input shaft
- Reverse idler gear and shaft
- Shift forks and pads
- Shift rails
- Roller detents
- Speedometer pinion
- All external covers

Observe following procedure:

- (1) Disconnect negative cable from battery.
- (2) Remove both shift cables from shift cover levers.
- (3) Remove left front wheel and tire assembly and left splash shield.
- (4) Place drain pan under transaxle and remove transaxle rear end cover.
- (5) Push out the fifth fork roll pin and slide the fifth fork and synchronizer sleeve off the rail/hub.
- (6) Remove the fifth hub snap ring, hub assembly and speed gear.

- (7) Remove fifth gear nut and fifth input gear.
- (8) Remove the bearing retainer plate, interlock plate and shuttles.

CAUTION: Before removing the gearshift housing assembly, reverse the lock pin (so the long end is down) and insert lock pin into the same threaded hole. This procedure will save time when the gear shift housing assembly is reinstalled.

- (9) Remove selector shaft housing bolts (note the two pilot bolts) and remove housing.

- (10) Remove roller detents and springs, noting that the rollers align with the shift rails.

- (11) Push out the 1-2 and 3-4 lug roll pins, remove the reverse pivot lever and fifth rail C-Clip. **If a roll pin or C-Clip falls, be sure to remove it from the bottom of the case.**

- (12) Pull out the fifth shift rail and remove the fifth shift lug and interlock pin. **If the pin falls, be sure to remove it from the bottom of the case.**

- (13) Remove the intermediate shaft ball bearing snap ring and the bearing support plate.

- (14) Remove reverse shift rail and lug assembly.

- (15) Remove the reverse idler shaft and gear assembly.

- (16) Rotate the 1-2 shift lug and rail, and 3-4 shift lug toward the front of the vehicle.

- (17) Firmly grasp both the input and intermediate shaft assemblies and pull them out of the transmission with the 1-2 and 3-4 shift rails, lugs and forks.

The differential assembly can only be serviced by removing the complete transaxle from the vehicle because bearing preload must be reset.

The components listed in the first paragraph can now be serviced. Refer to the appropriate **subassembly recondition** section.

To reassemble the transaxle in the vehicle, reverse the above procedure using the proper sealants. Fill the transaxle with SAE 5W-30 engine oil to the bottom of the fill hole in the end cover.

TRANSAXLE REMOVAL AND INSTALLATION

Transaxle removal does not require engine removal.

After installing transaxle, fill transaxle to bottom of fill plug hole with SAE 5W-30 engine oil before lowering vehicle to floor.

- (1) Disconnect or connect **negative** battery cable.
- (2) Install a **lifting eye** on battery ground strap bolt on left side of engine and install the engine support fixture as shown in Figure 11.
- (3) Disconnect or connect gearshift cables at transaxle. Disconnect speedometer. Disconnect or connect gearshift cables bracket at transaxle.
- (4) Remove or install both front wheel and tire assemblies.
- (5) Remove or install left front splash shield.
- (6) Remove or install engine left mount from transaxle.

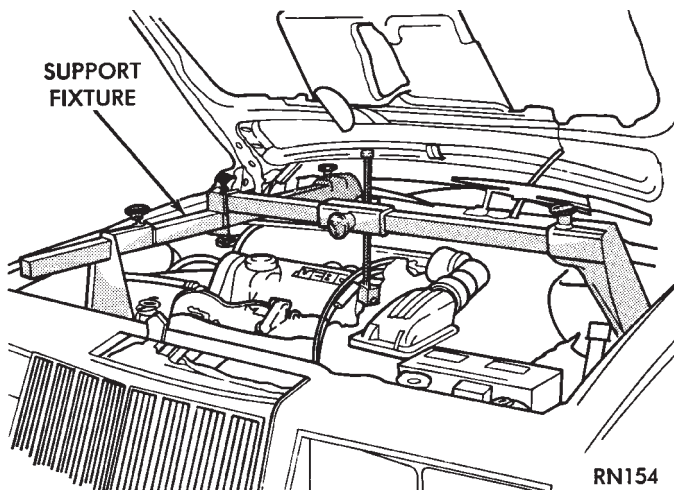

Fig. 11 Engine Support Fixture

CAUTION: Bolts used for position number 1 and number 3 are the same length. The bolt in the number 2 position is longer. If bolt number 2 is used in position number 3 it can damage the selector shaft housing when the bolt is seated (Fig. 12).

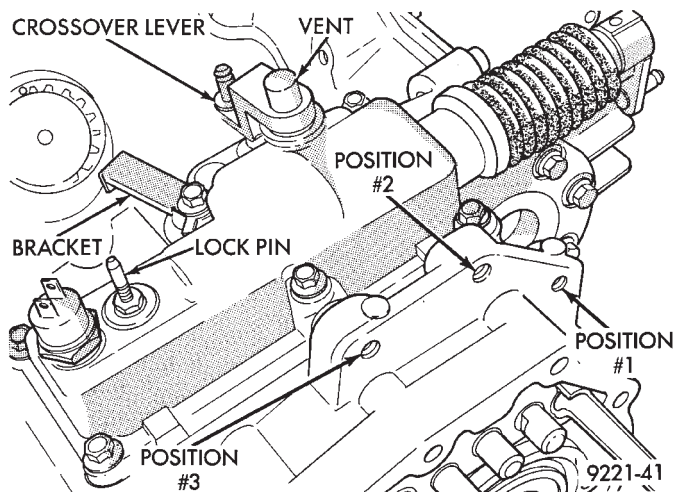

Fig. 12 Left Engine Mount Bolt Location

(7) Remove or install anti-rotational link (or anti-hop damper) from crossmember bracket. **Do not remove bracket from transaxle.**

(8) Refer to Group 2 **Suspension**, to remove or install both drive shafts.

When removing or installing the transaxle, it may be helpful to use two locating pins in place of the top two transaxle to engine block bolts (Fig. 13).

Make the locating pins from two stock (transaxle case to engine block) bolts as follows: Using a hacksaw, remove bolt heads, cut slot in end of bolts for a screw driver, and remove burrs with a grinding wheel. Install the locating pins into the engine block and proceed with transaxle installation. After transaxle is in place, install bolts and remove locating pins before removing transmission jack.

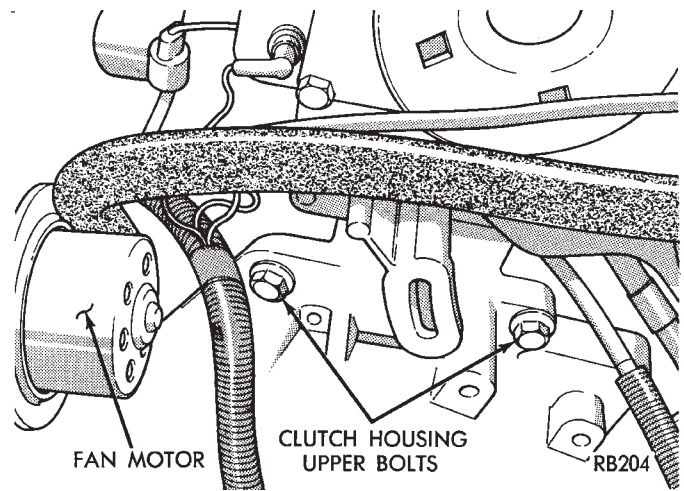

Fig. 13 Remove or Install Bolts

OUT OF CAR TRANSAXLE—DISASSEMBLE AND ASSEMBLE

DIFFERENTIAL

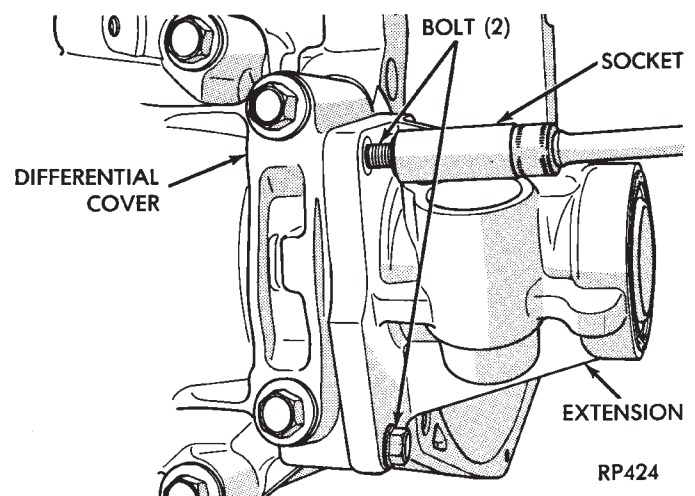

Fig. 1 Remove or Install 2 Extension Outer Bolts

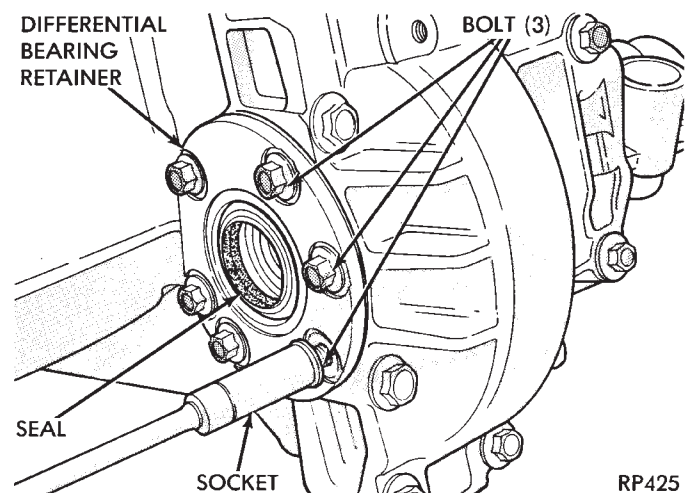

Fig. 2 Remove or Install 3 Differential Bearing Retainer Outer Bolts

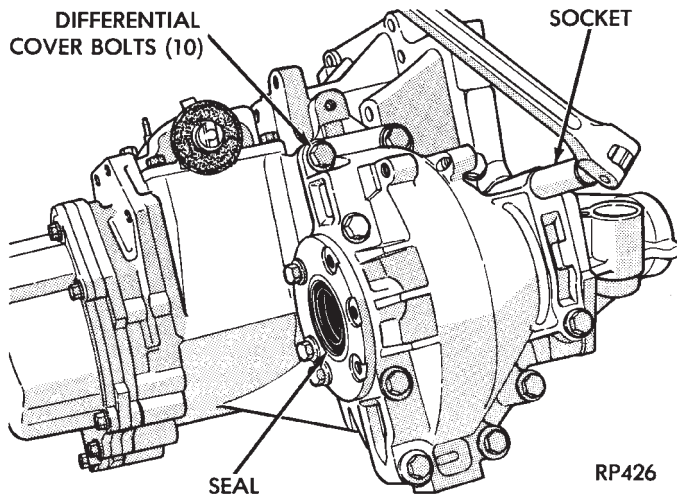

Fig. 3 Remove or Install Differential Cover Bolts

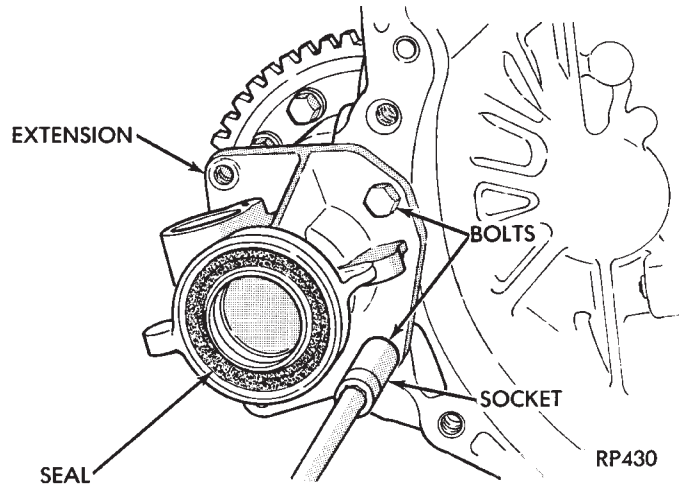

Fig. 6 Remove or Install 2 Extension Bolts

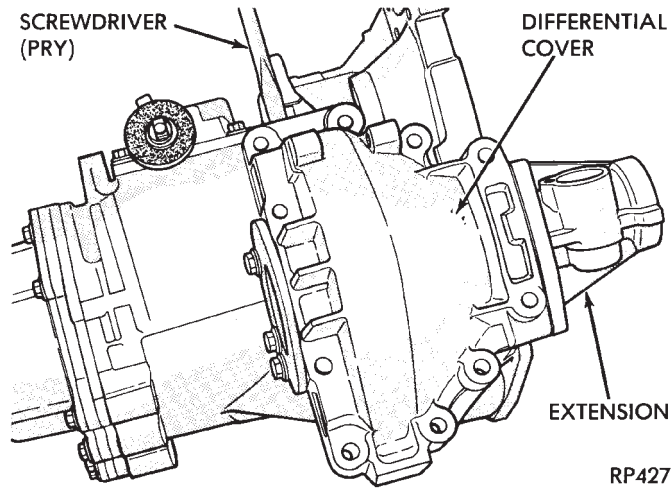

Fig. 4 Remove Differential Cover

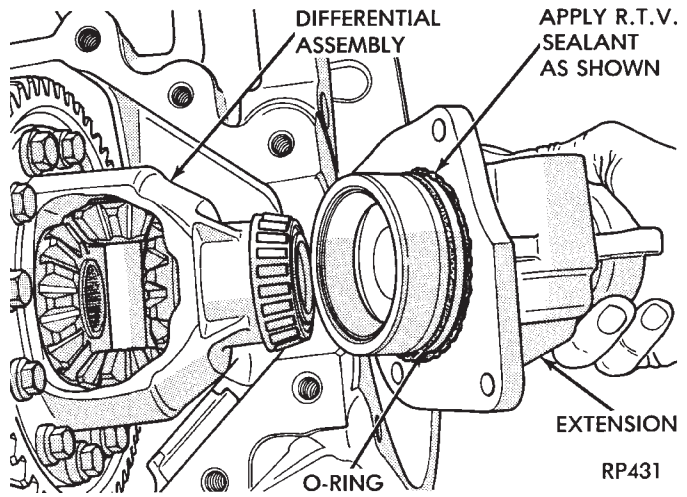

Fig. 7 Remove or Install Extension

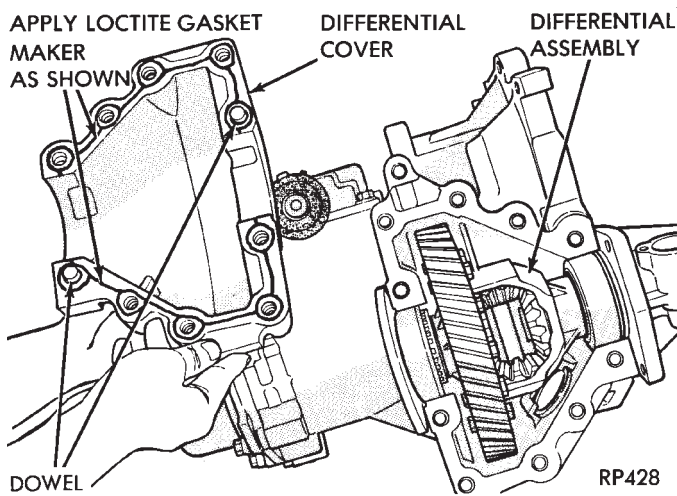

Fig. 5 Differential Cover Removed

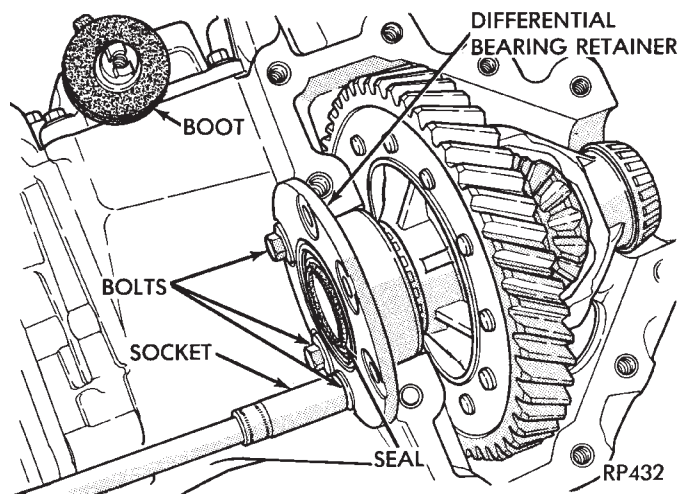

Fig. 8 Remove or Install 3 Differential Bearing Retainer Bolts

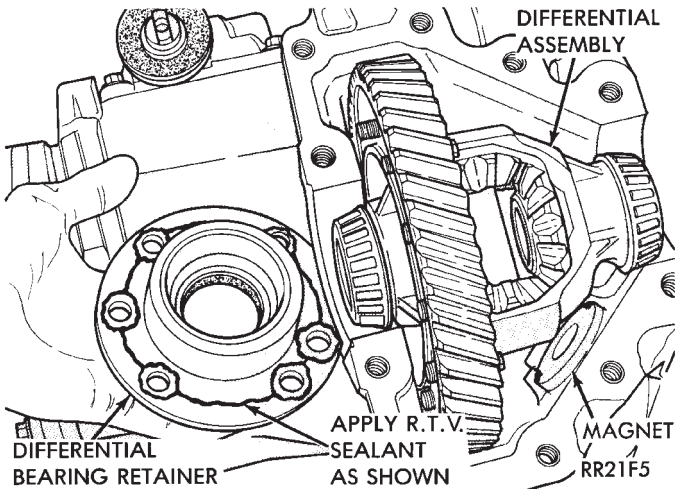

Fig. 9 Remove or Install Differential Bearing Retainer

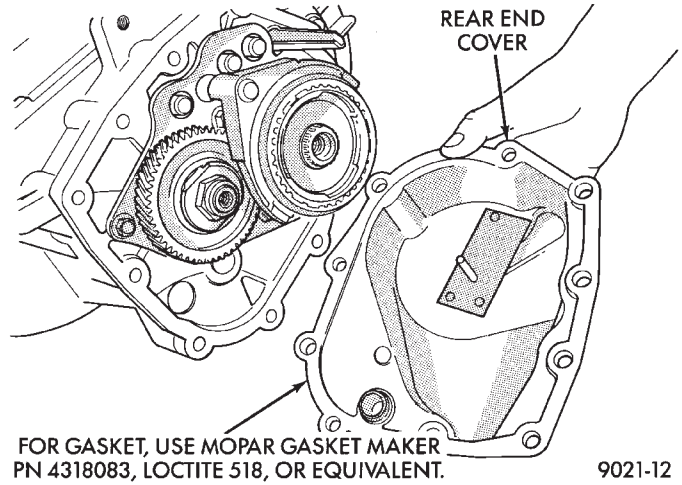

Fig. 2 Rear End Cover Removed

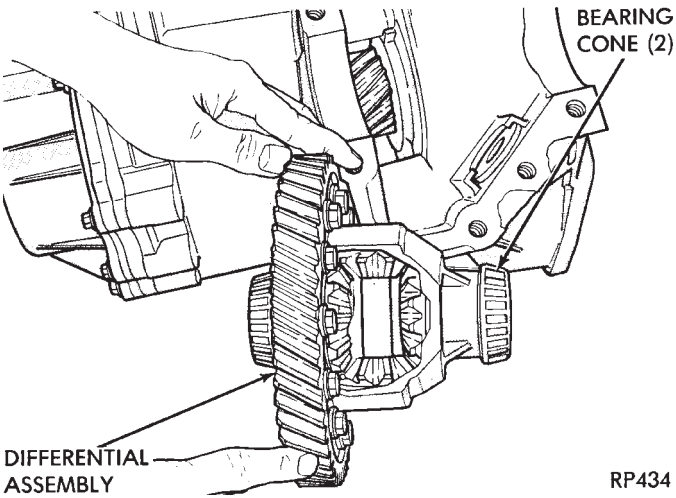

Fig. 10 Differential Assembly Removed GEAR SET

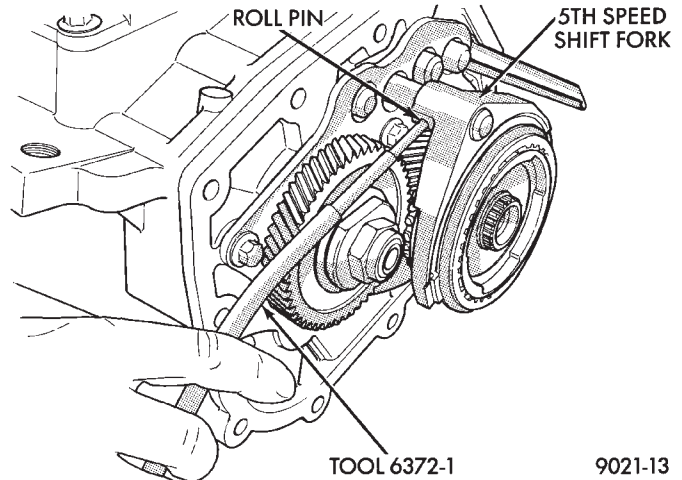

Fig. 3 Remove 5th Fork Roll Pin

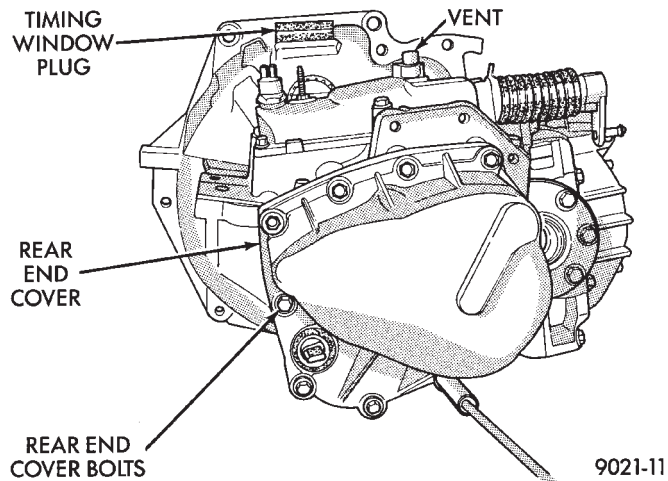

Fig. 1 Rear End Cover Bolts

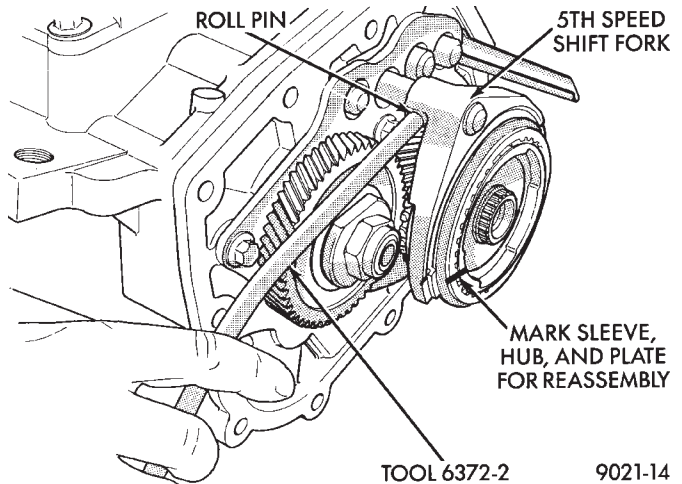
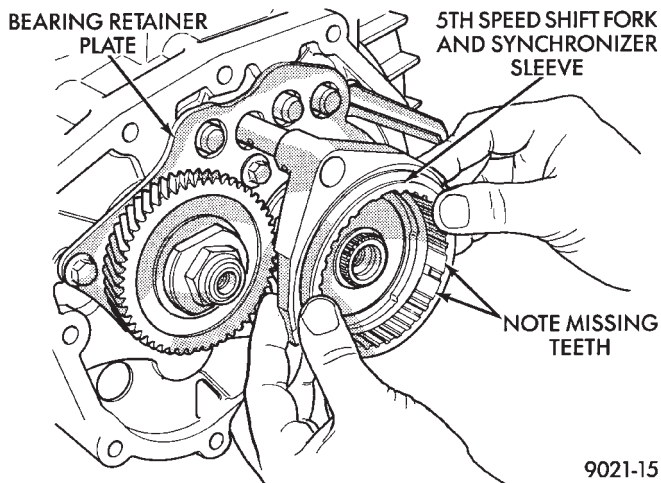
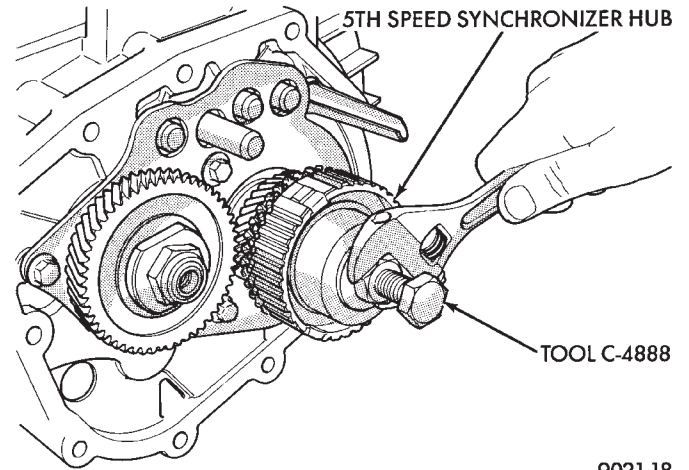

Fig. 4 Install 5th Fork Roll Pin



9021-15

Fig. 5 5th Fork and Sleeve



9021-18

Fig. 8 Install 5th Synchronizer Hub

CAUTION: Tool 6252 must be used to remove or install this nut. Always install a NEW nut and tighten to 258 N•m (190 ft. lbs.).

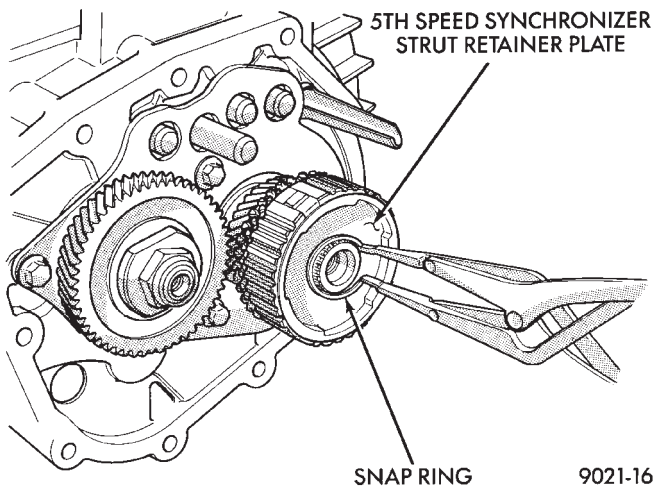

9021-16

Fig. 6 Snap Ring

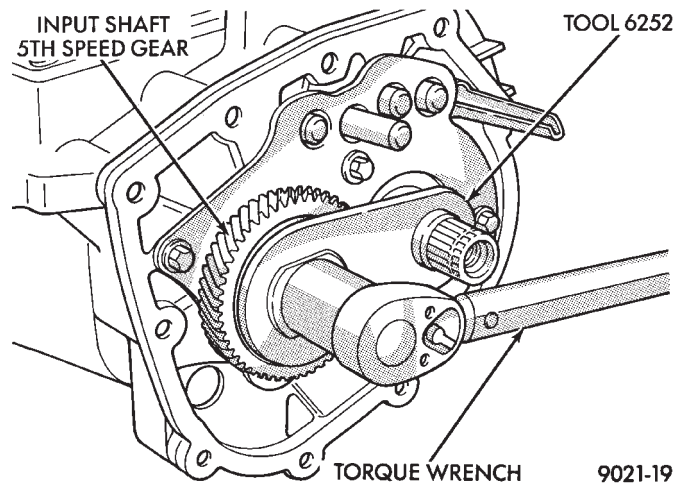

9021-19

Fig. 9 Remove or Install 5th Gear Nut

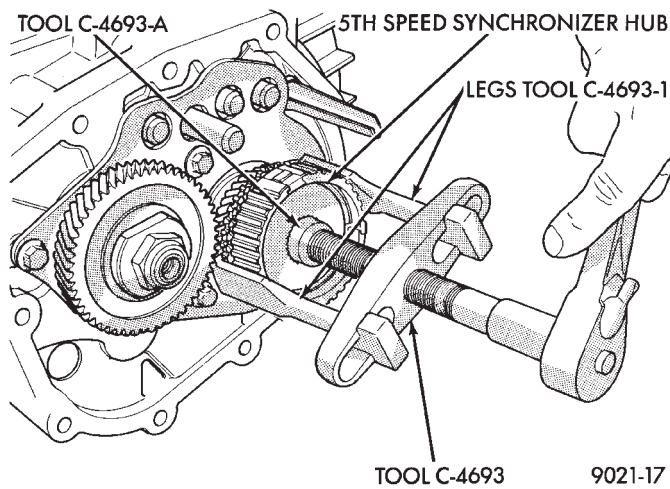

9021-17

Fig. 7 Remove 5th Synchronizer Hub

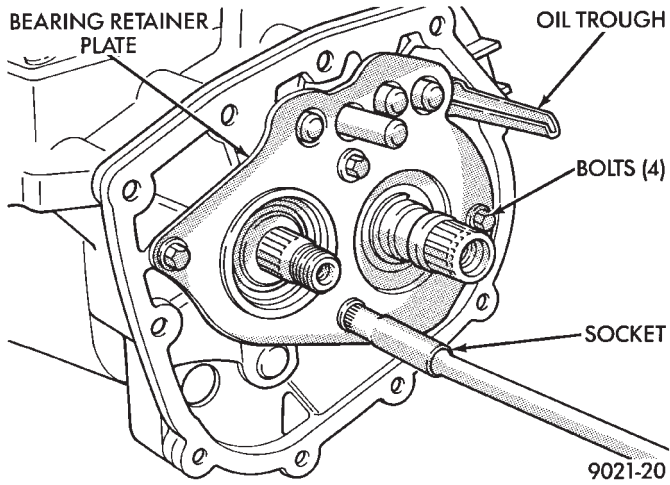

Fig. 10 Bearing Retainer Plate Bolts

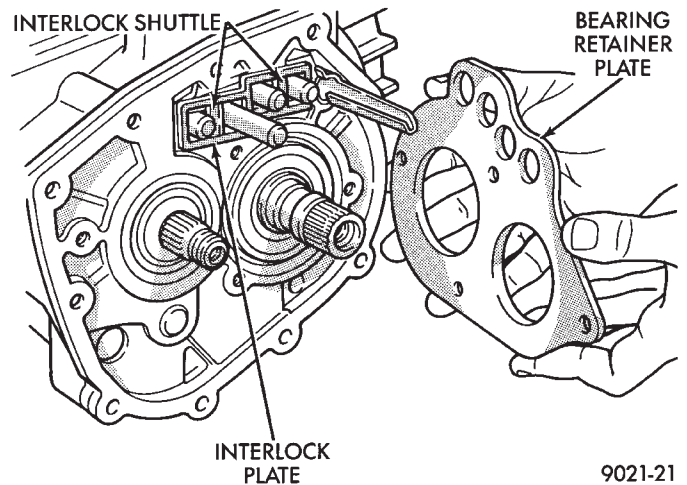

Fig. 11 Bearing Retainer Plate

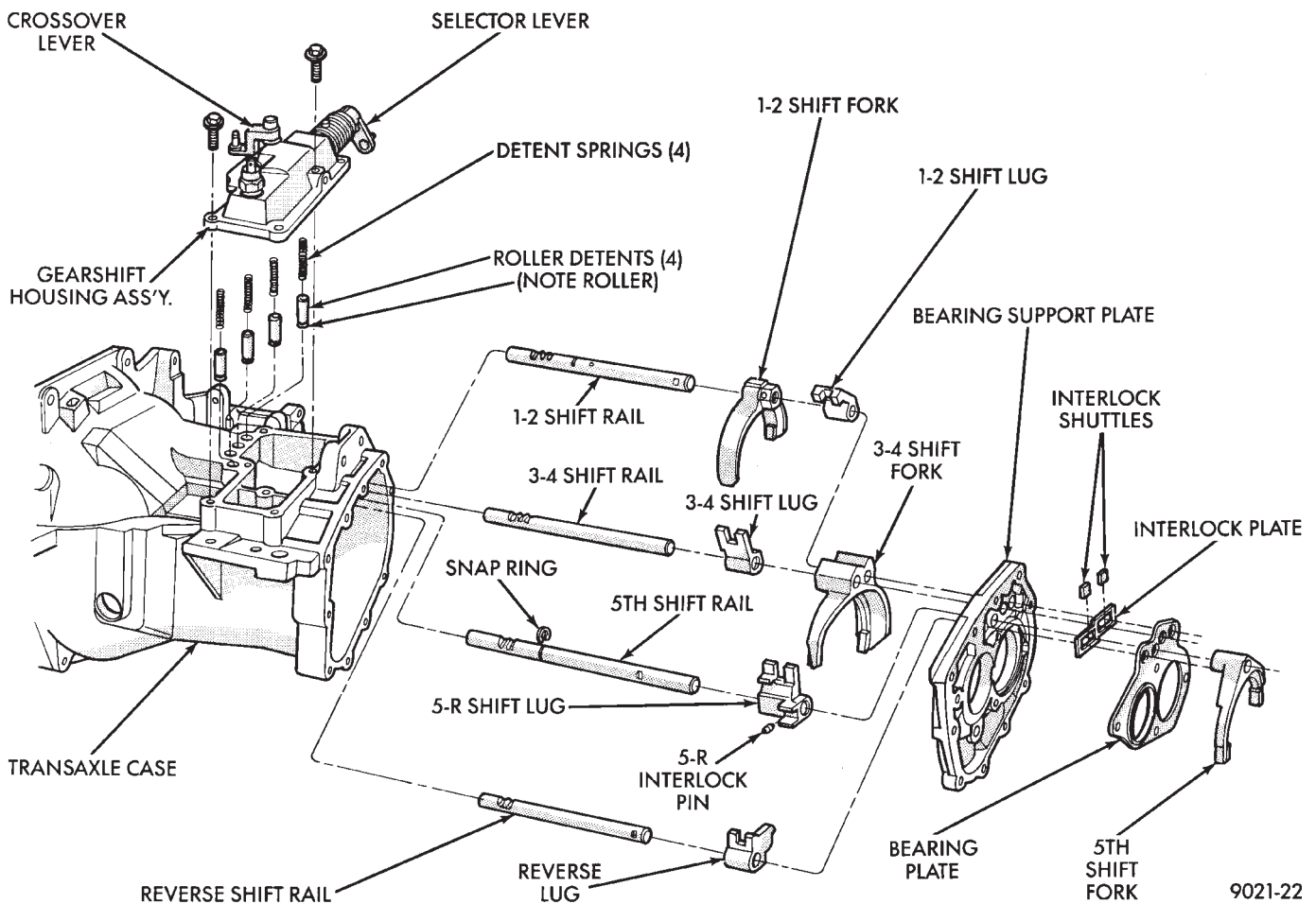

Fig. 12 A-523 Shift Forks and Shift Rail Components

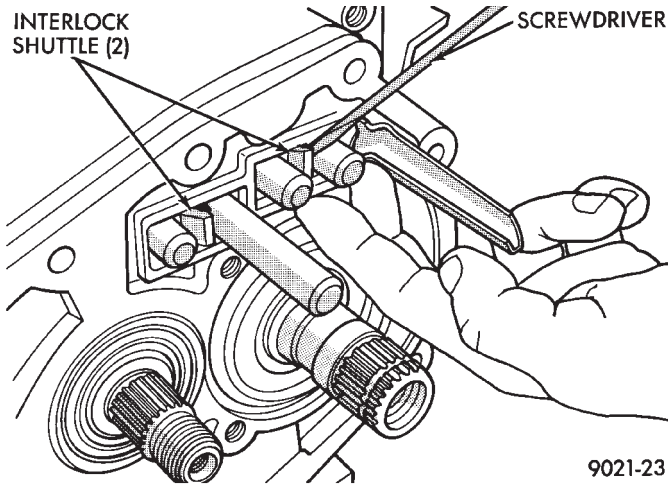

Fig. 13 Interlock Shuttles

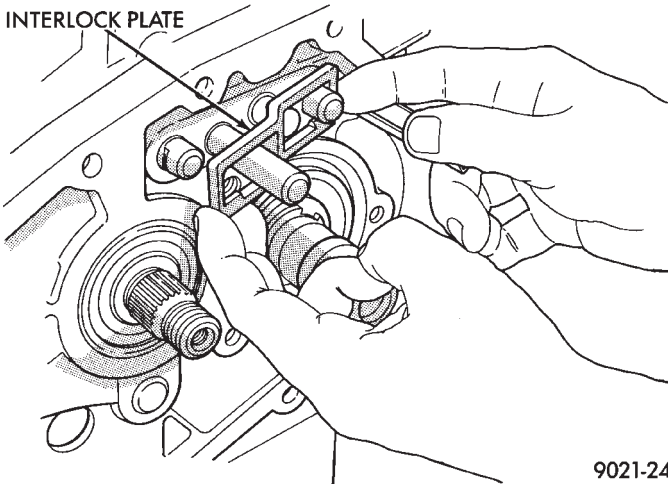

Fig. 14 Interlock Plate

CAUTION: Before removing the gearshift housing, reverse the lock pin (so the long end is down) and insert lock pin into the same threaded hole. This procedure will save time when the gearshift housing assembly is reinstalled.

To install gearshift housing, be sure to reverse the lock pin in the housing to lock the selector shaft in the 3-4 neutral position.

CAUTION: Install roller detents so roller and slots are parallel with shift rails.

Remove or install 3-4 lug roll pin, 3-4 fork roll pin, and reverse lug roll pin using the above procedure.

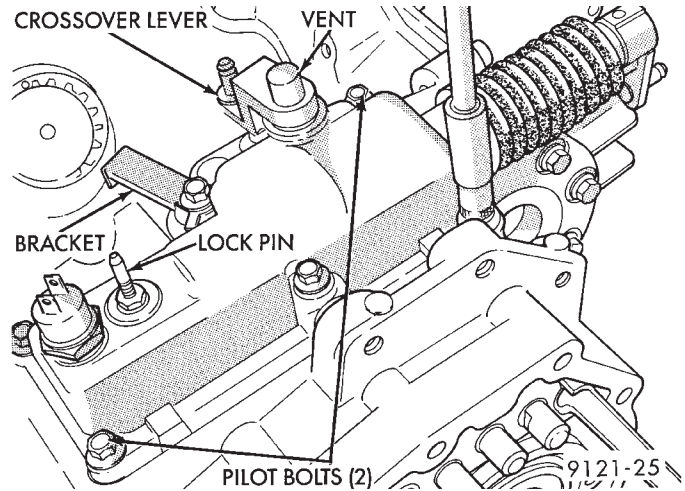

Fig. 15 Gearshift Housing Bolts

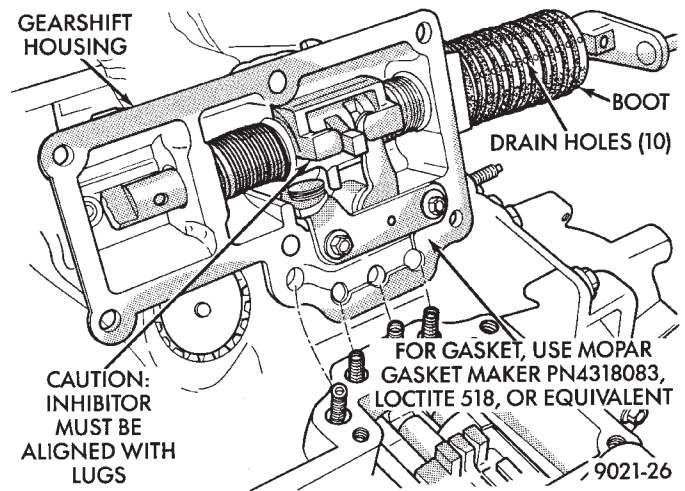

Fig. 16 Gearshift Housing Removed

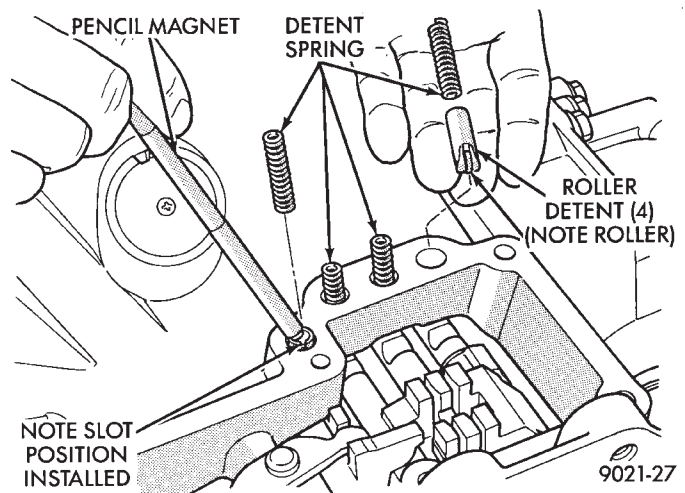

Fig. 17 Remove Roller Detents

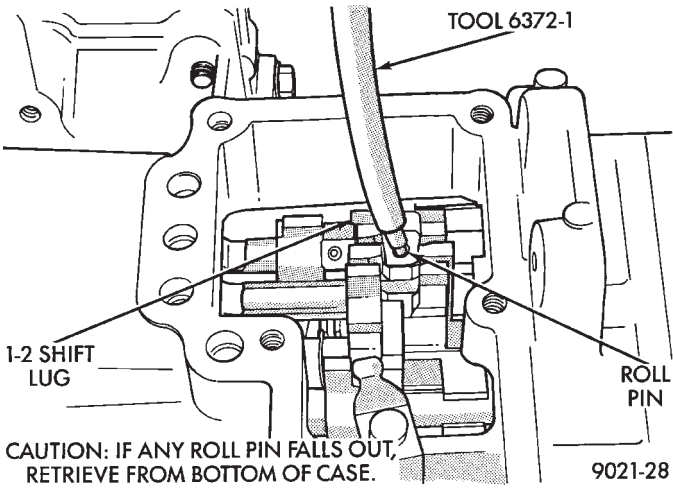

Fig. 18 Remove 1-2 shift Lug Roll Pin

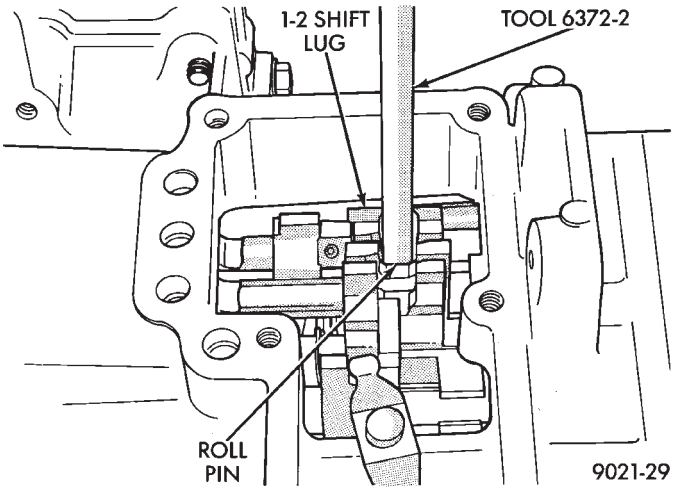

Fig. 19 Install 1-2 Shift Lug Roll Pin

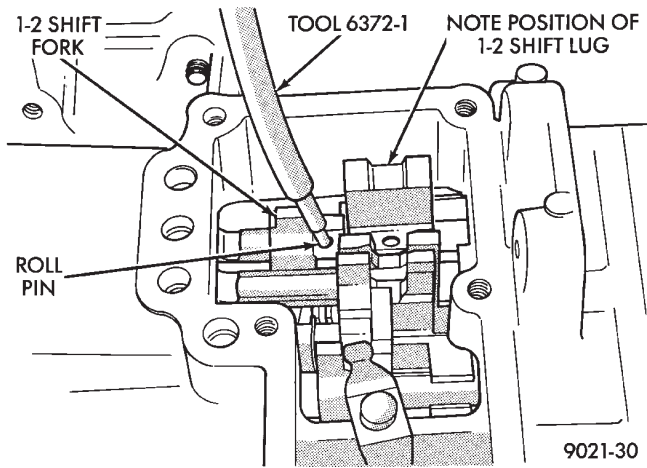

Fig. 20 Remove 1-2 Shift Fork Roll Pin

CAUTION: If any roll pin falls out, retrieve roll pin from bottom of case.

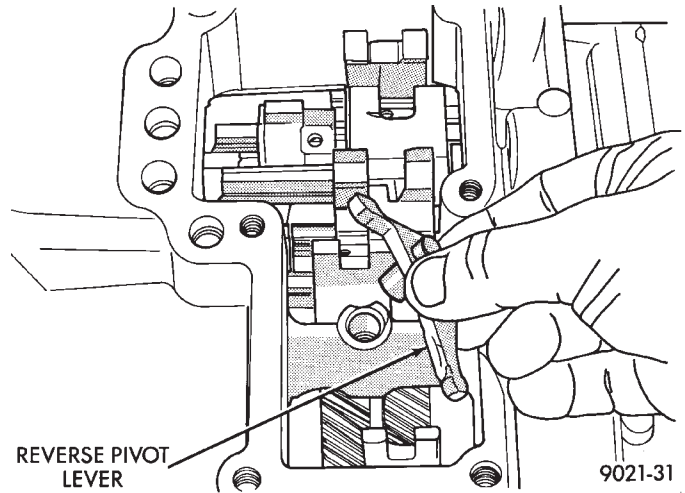

Fig. 21 Reverse Pivot Lever

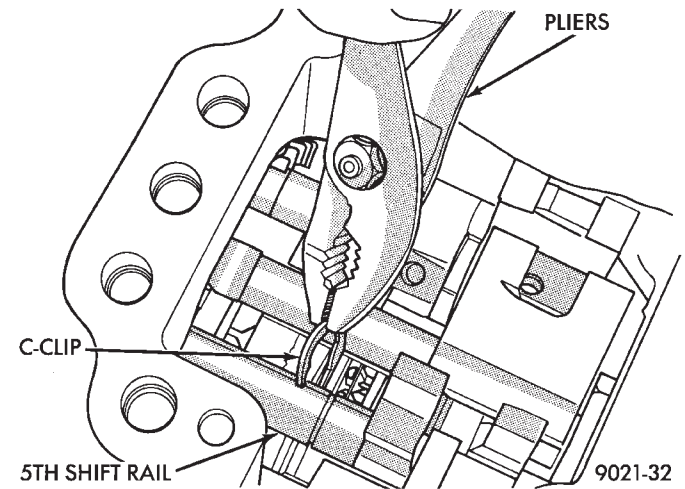

Fig. 22 5th Shift Rail C-Clip

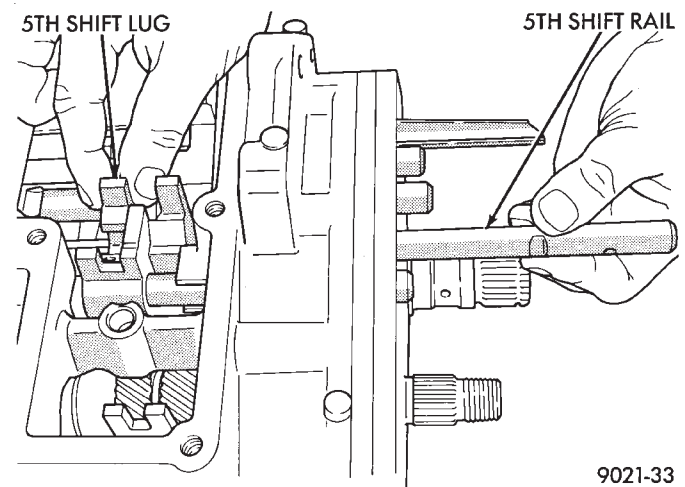

Fig. 23 5th Shift Rail and Shift Lug

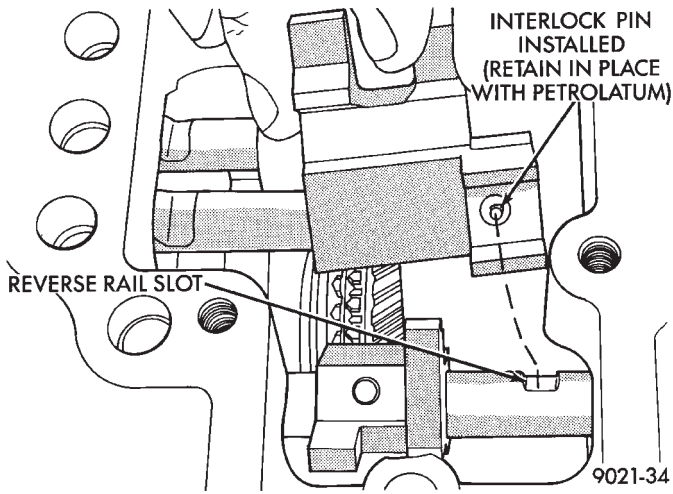

Fig. 24 5th Shift Lug with Interlock Pin

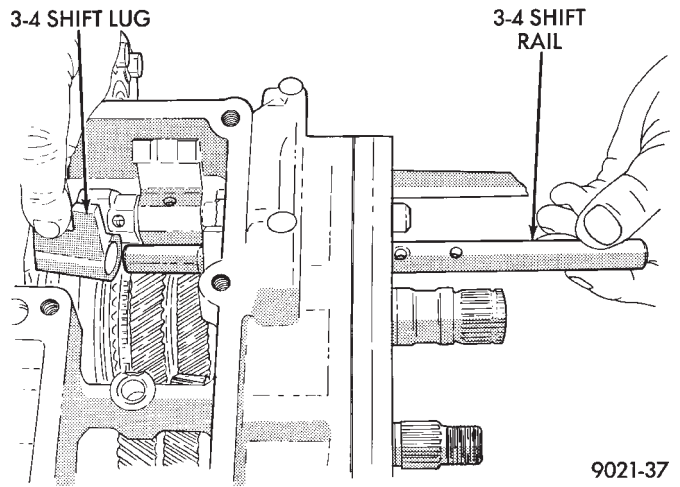

Fig. 27 3-4 Shift Rail and Shift Lug

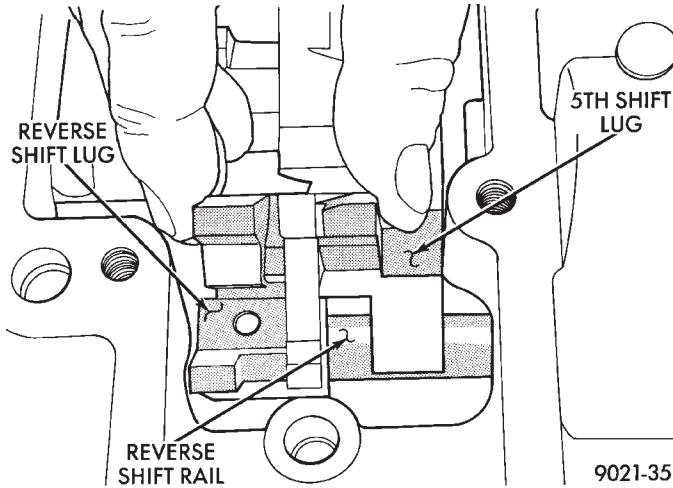

Fig. 25 5th Shift Lug Properly Installed

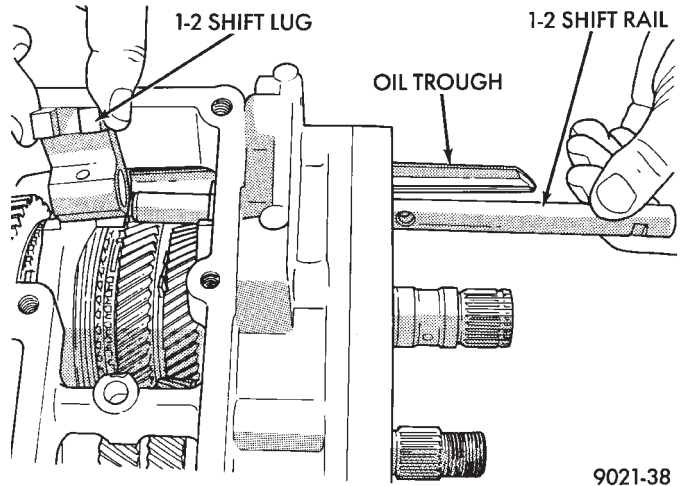

Fig. 28 1-2 Shift Rail and Shift Lug

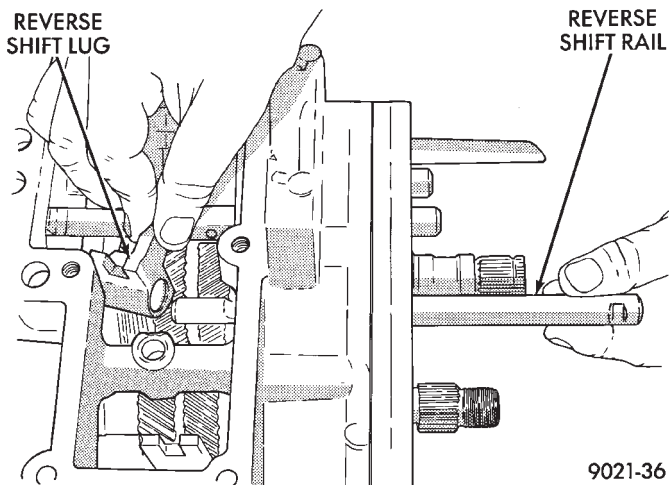

Fig. 26 Reverse Shift Rail and Shift Lug

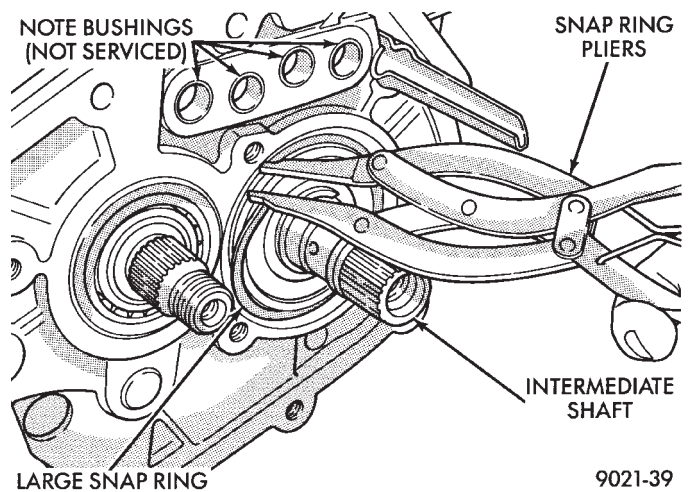

Fig. 29 Remove or Install Large Snap Ring



CAUTION: Pry only at slot as shown (Fig. 30).

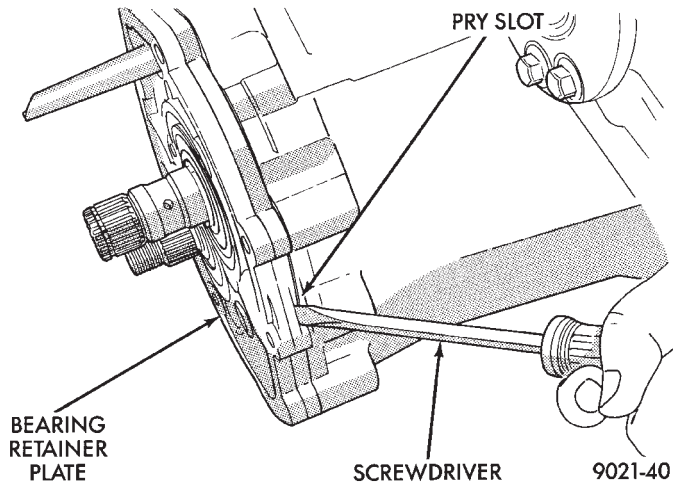

Fig. 30 Pry Bearing Retainer Plate to Remove

FOR GASKET, USE MOPAR GASKET MAKER PN 4318083 OR LOCTITE 518, OR EQUIVALENT.

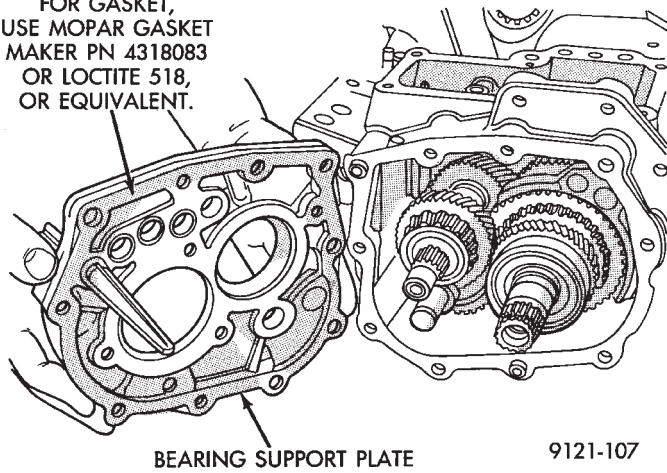

Fig. 31 Bearing Support Plate

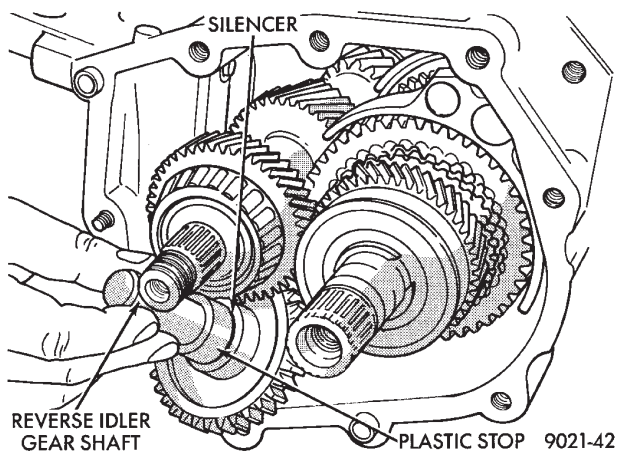

Fig. 32 Remove or Install Reverse Idler Gear

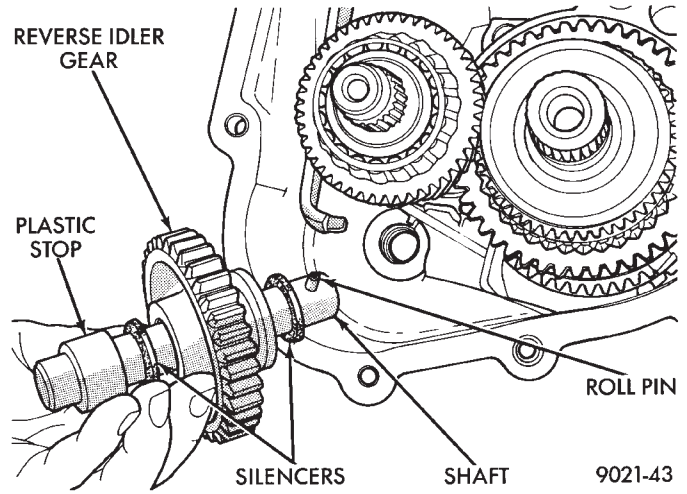

Fig. 33 Reverse Idler Gear Assembly

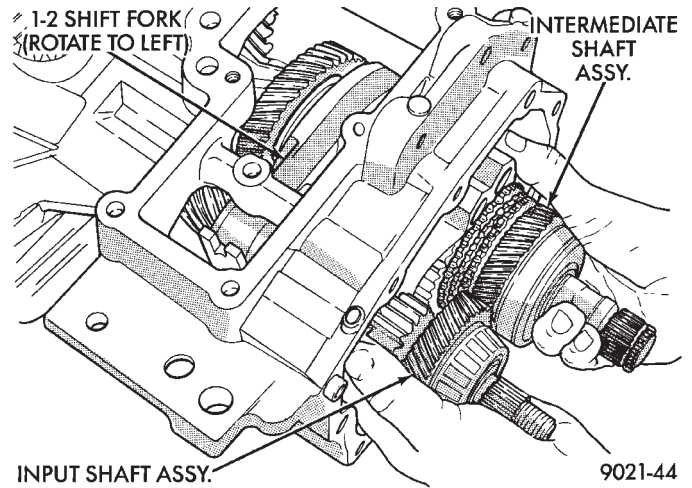

Fig. 34 Remove or Install Gear Set

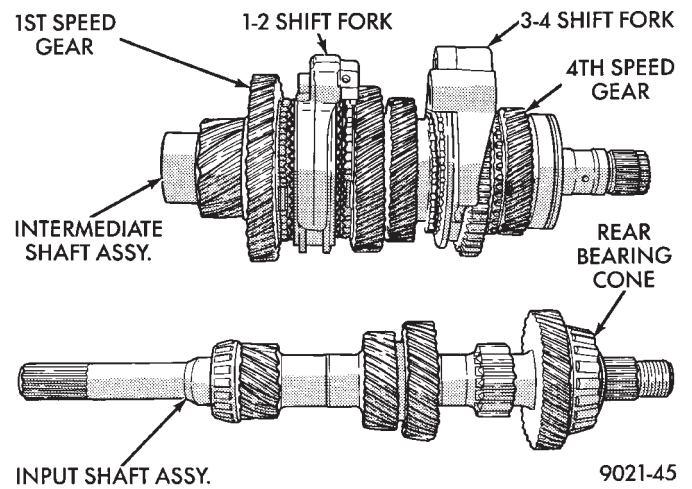

Fig. 35 Gear Set



CLUTCH RELEASE BEARING

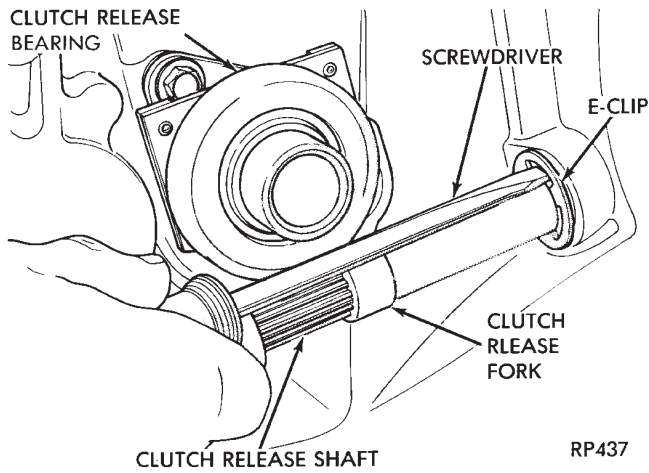

Fig. 1 Remove Retaining E-Clip

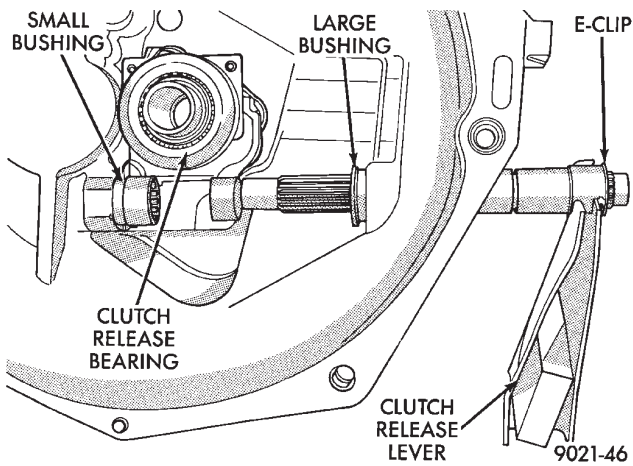

Fig. 2 Remove or Install Clutch Release Shaft

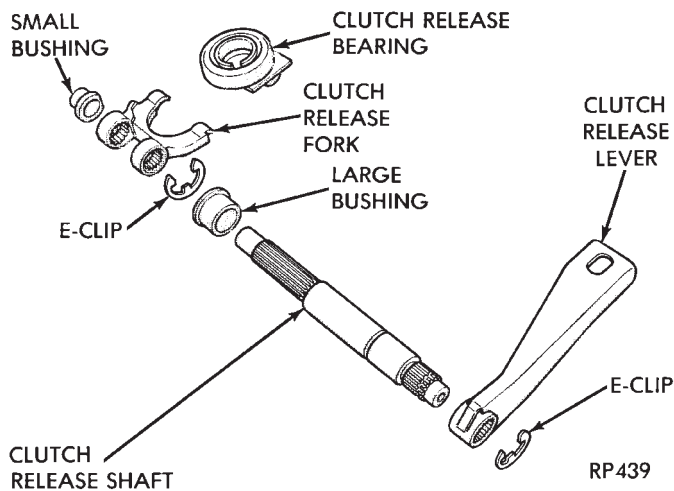

Fig. 3 Clutch Release Shaft Components

INPUT SHAFT OIL SEAL

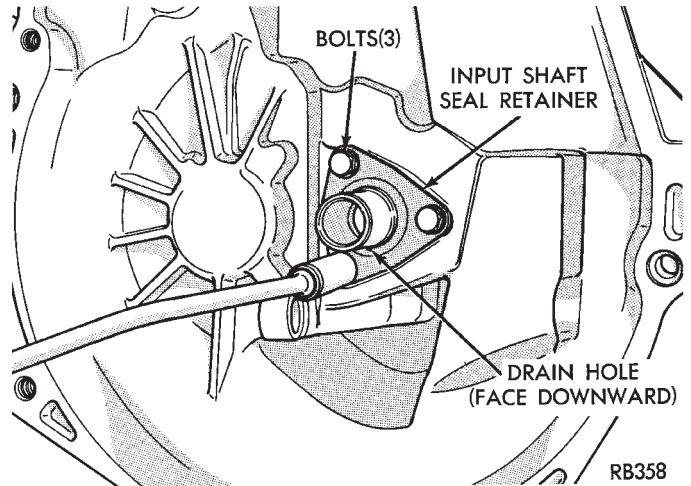

Fig. 4 Remove or Install Input Shaft Seal Retainer

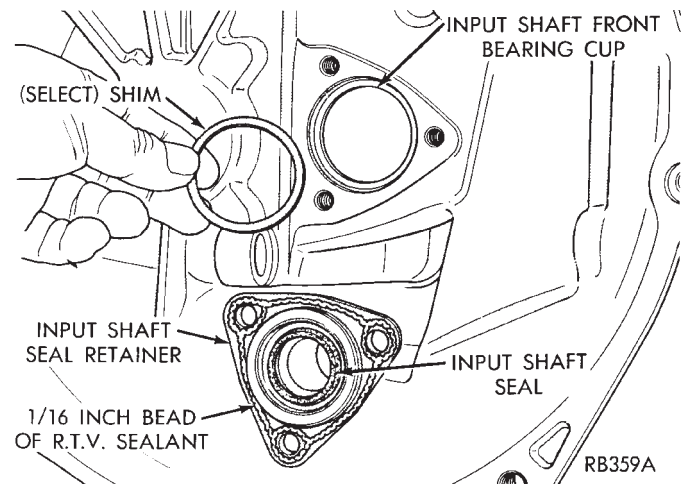

Fig. 5 Input Shaft Seal Retainer

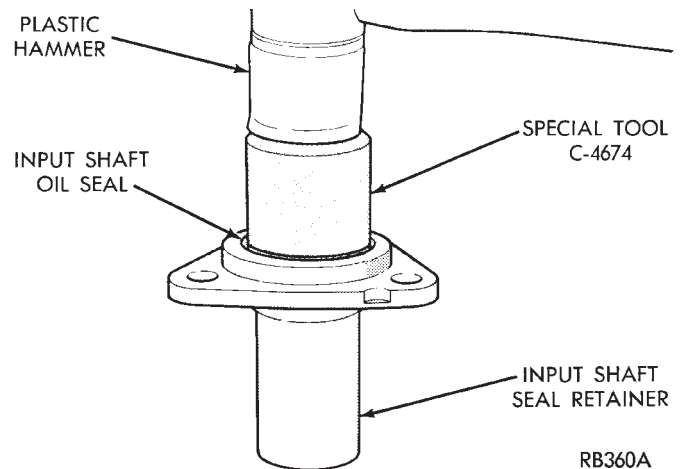

Fig. 6 Install New Input Shaft Seal



REVERSE SHIFT LEVER

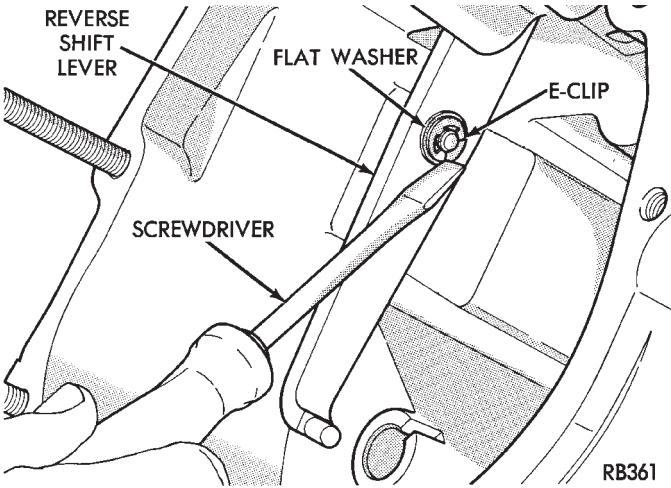

Fig. 7 Remove or Install Reverse Shift Lever E-Clip

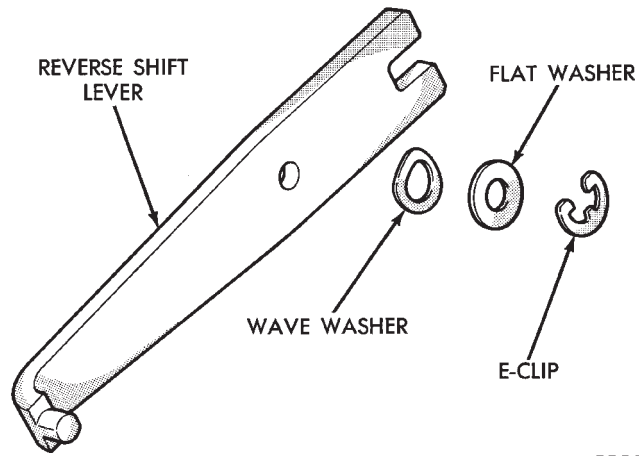

Fig. 8 Reverse Shift Lever Components

SUBASSEMBLY-RECONDITION

TRANSAXLE CASE

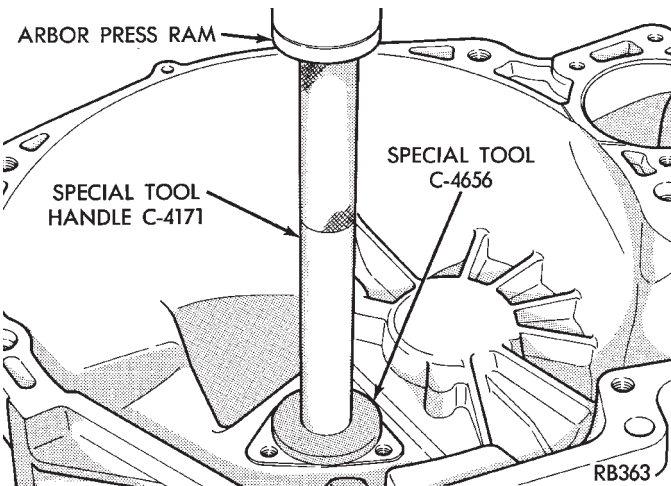

Fig. 1 Remove Input Shaft Front Bearing Cup

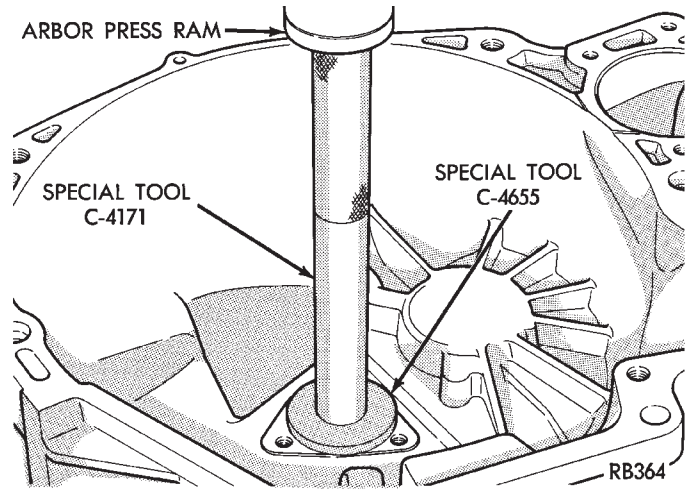

Fig. 2 Install Input Shaft Front Bearing Cup

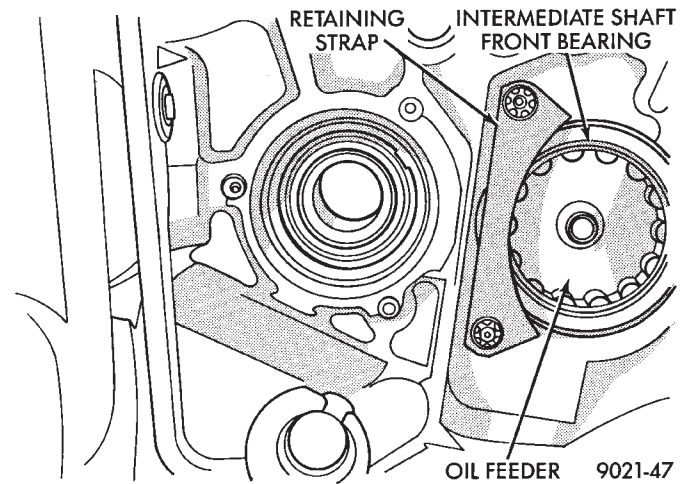

Fig. 3 Remove or Install Bearing Retaining Strap

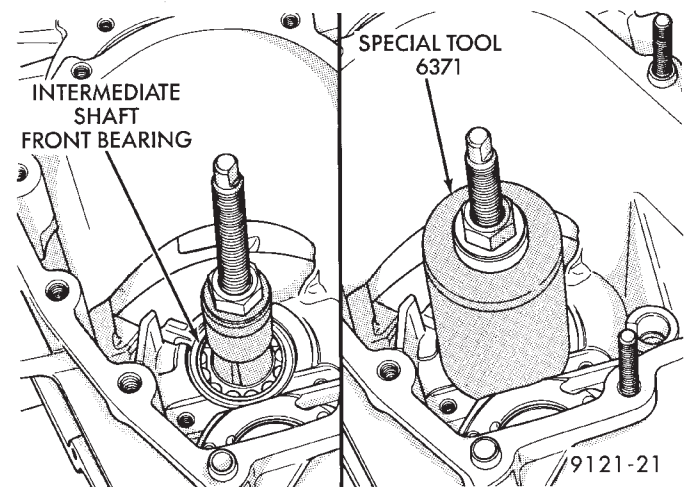

Fig. 4 Remove Intermediate Shaft Front Bearing

Use Tool C-4660-2A Screw. The screw has a larger hole in the lower end to fit over the larger oil feeder nipple (Fig. 5).

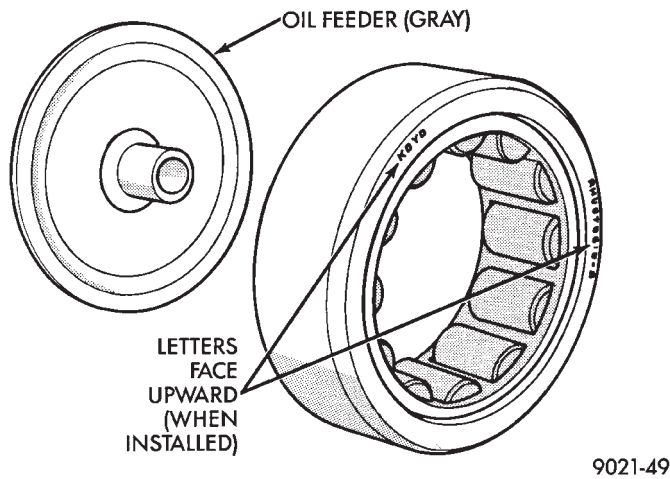

Fig. 5 Oil Feeder

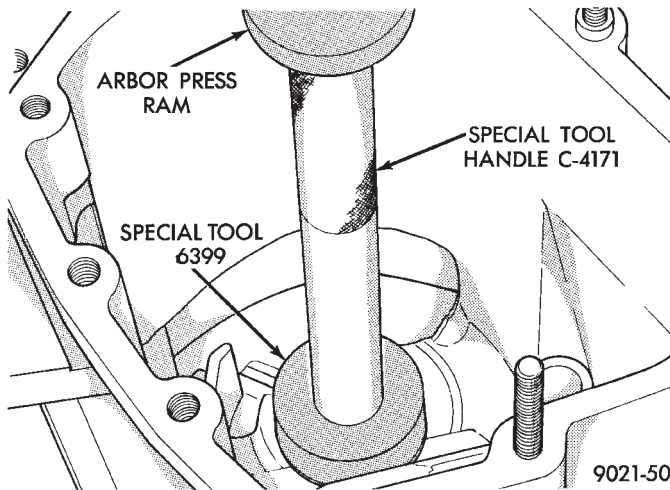

Fig. 6 Install Intermediate Shaft Front Bearing

INTERMEDIATE SHAFT ASSEMBLY

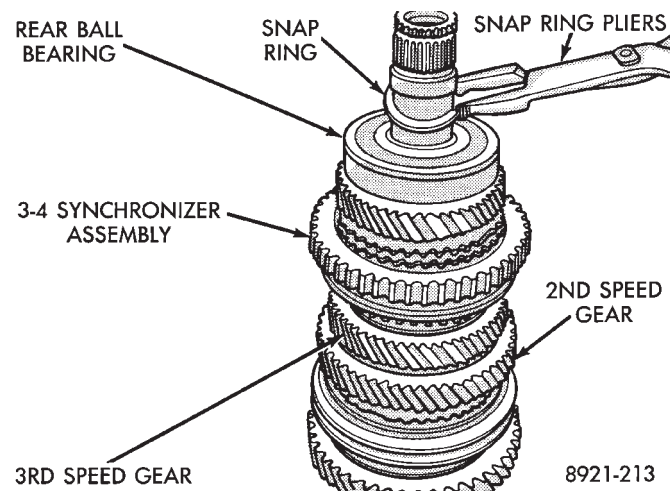

Fig. 1 Intermediate Shaft Bearing Snap Ring

When assembling intermediate shaft, make sure all speed gears turn freely.

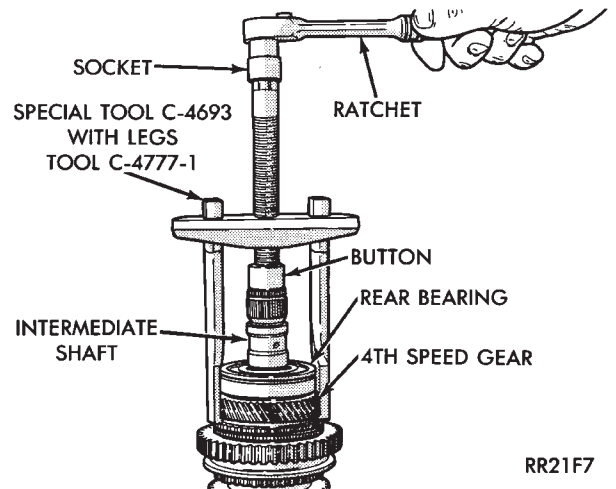

Fig. 2 Remove Intermediate Shaft Rear Bearing

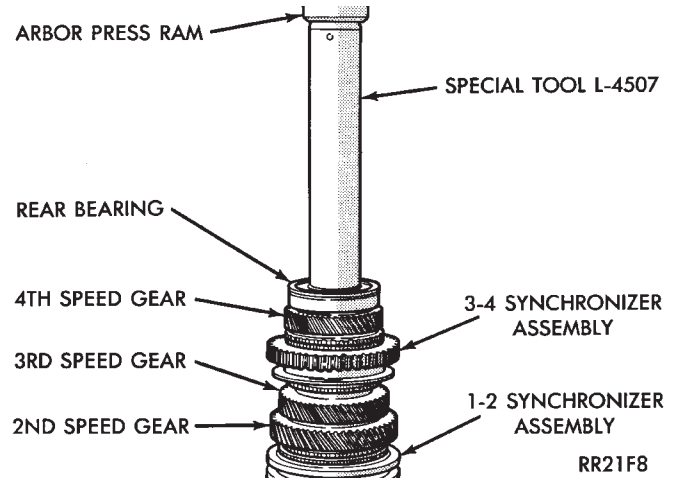

Fig. 3 Install Intermediate Shaft Rear Bearing

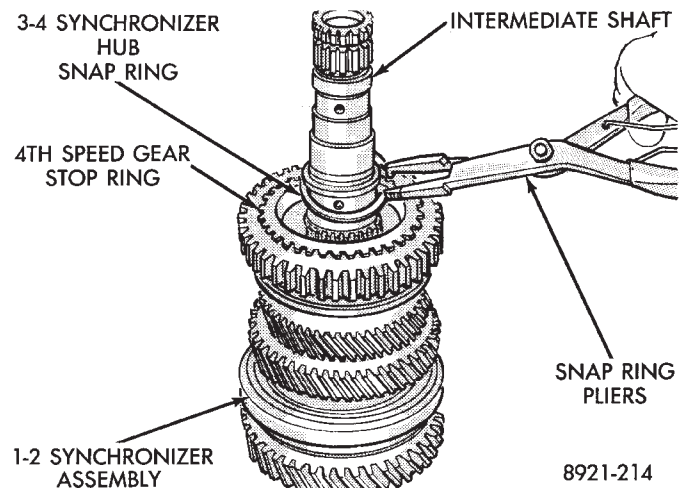

Fig. 4 3-4 Synchronizer Hub Snap Ring

CAUTION: Index snap ring 90 degrees to the split in the thrust washer, as shown above.

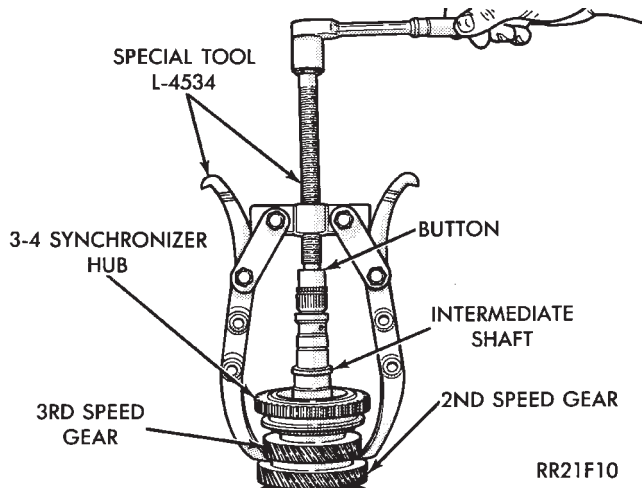

Fig. 5 Remove 3-4 Synchronizer Hub and 3rd Speed Gear

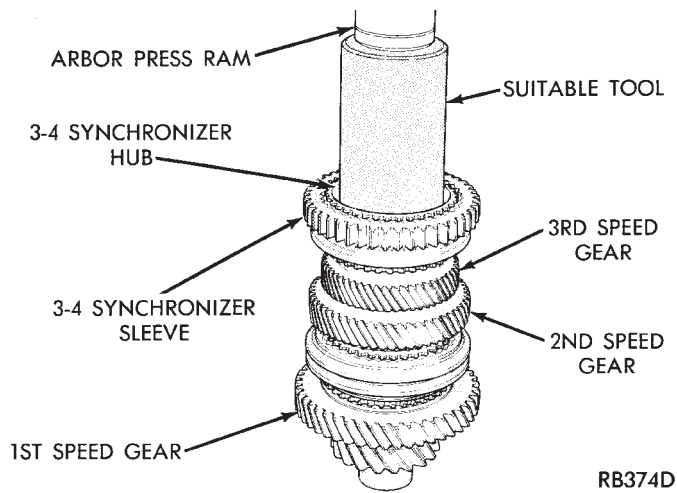

Fig. 6 Install 3-4 Synchronizer Hub and 3rd Speed Gear

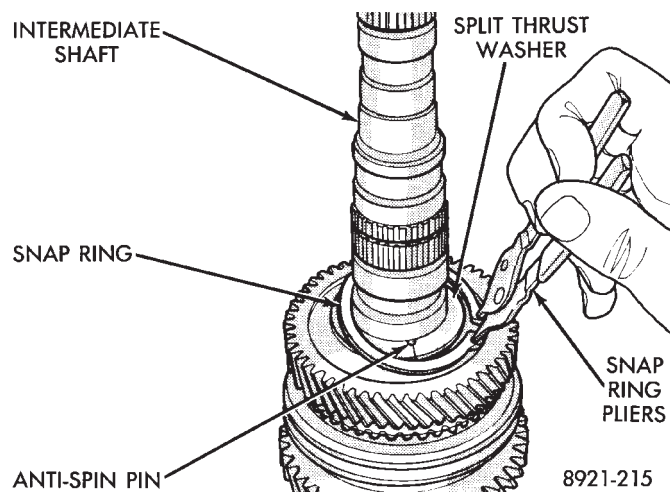

Fig. 7 Snap Ring and Split Thr'ust Washer

1-2 SYNCHRONIZER (DUAL-CONE)

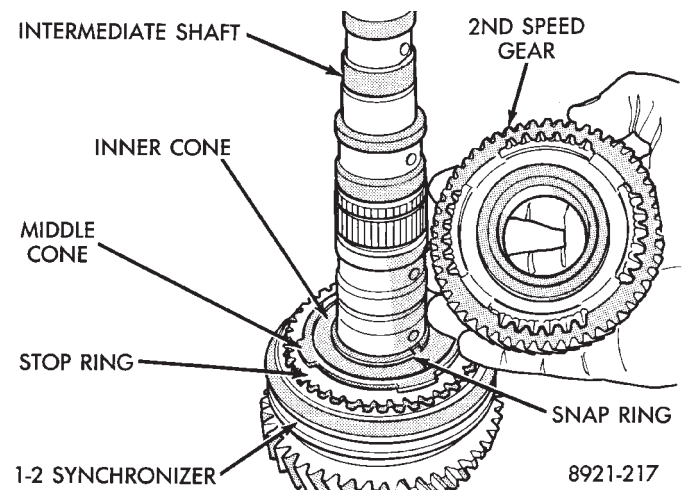

Fig. 1 2nd Speed Gear

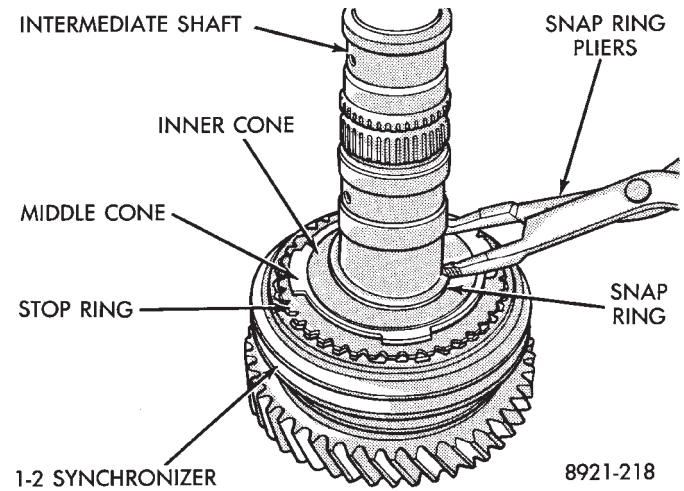

Fig. 2 1-2 Synchronizer Hub Snap Ring

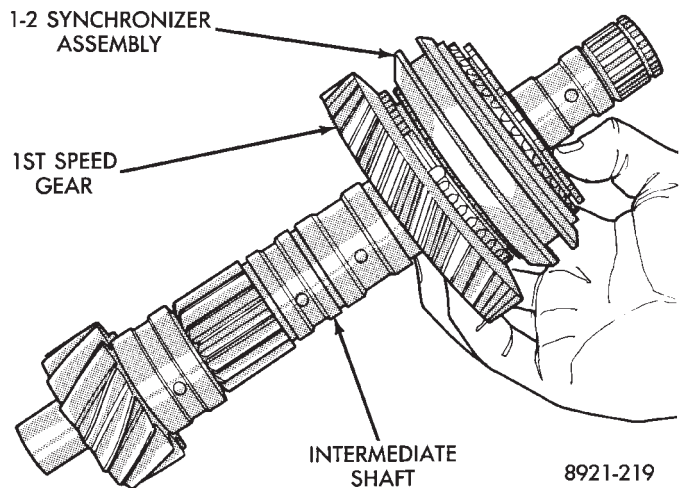

Fig. 3 1st Speed Gear and 1-2 Synchronizer Assembly

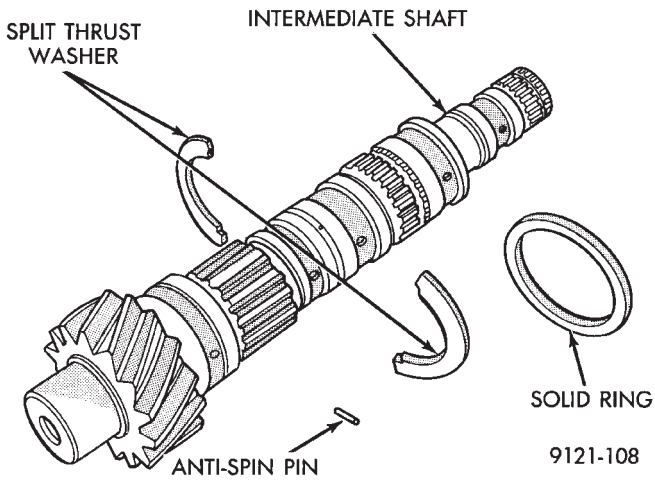

Fig. 4 Split Thrust Washer

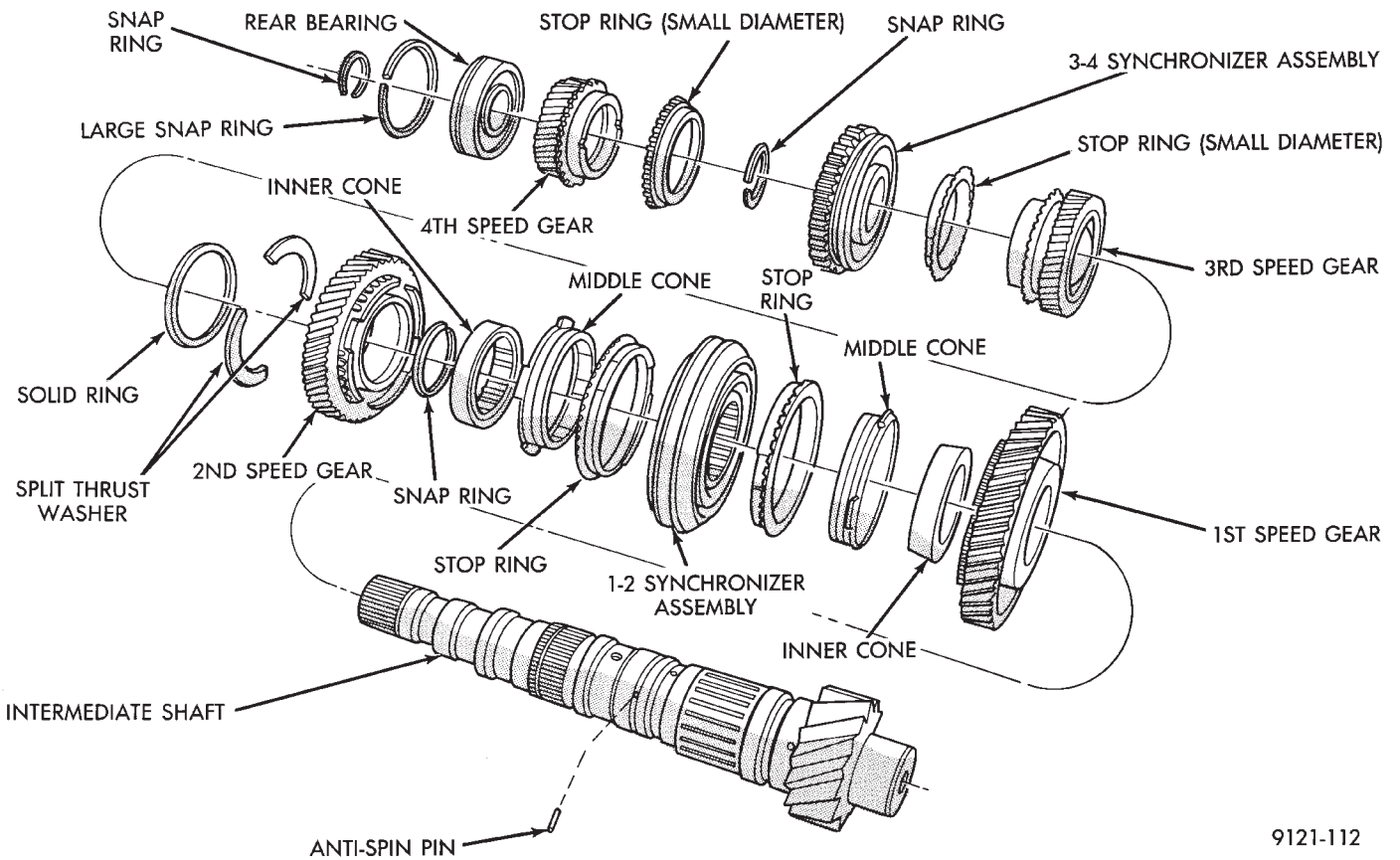
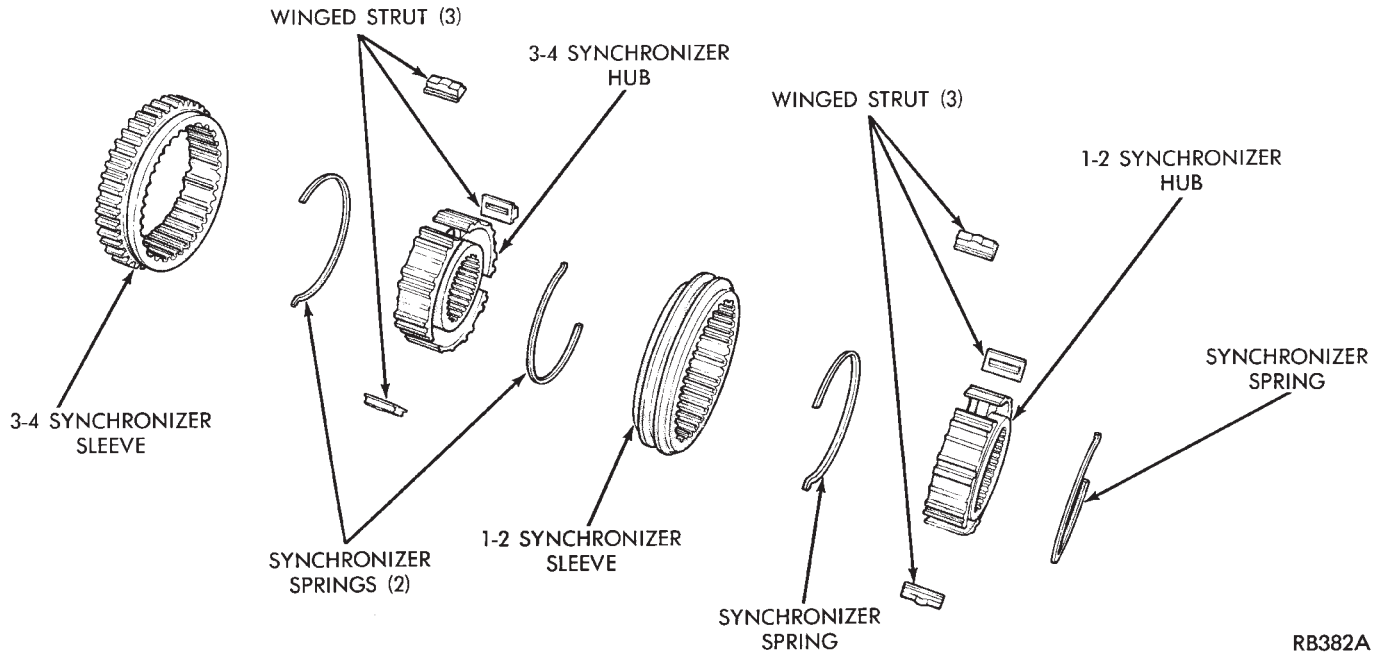

Fig. 5 Intermediate Shaft Assembly

SYNCHRONIZERS



RB382A

Fig. 6 1-2 and 3-4 Synchronizer Sleeves and Hubs

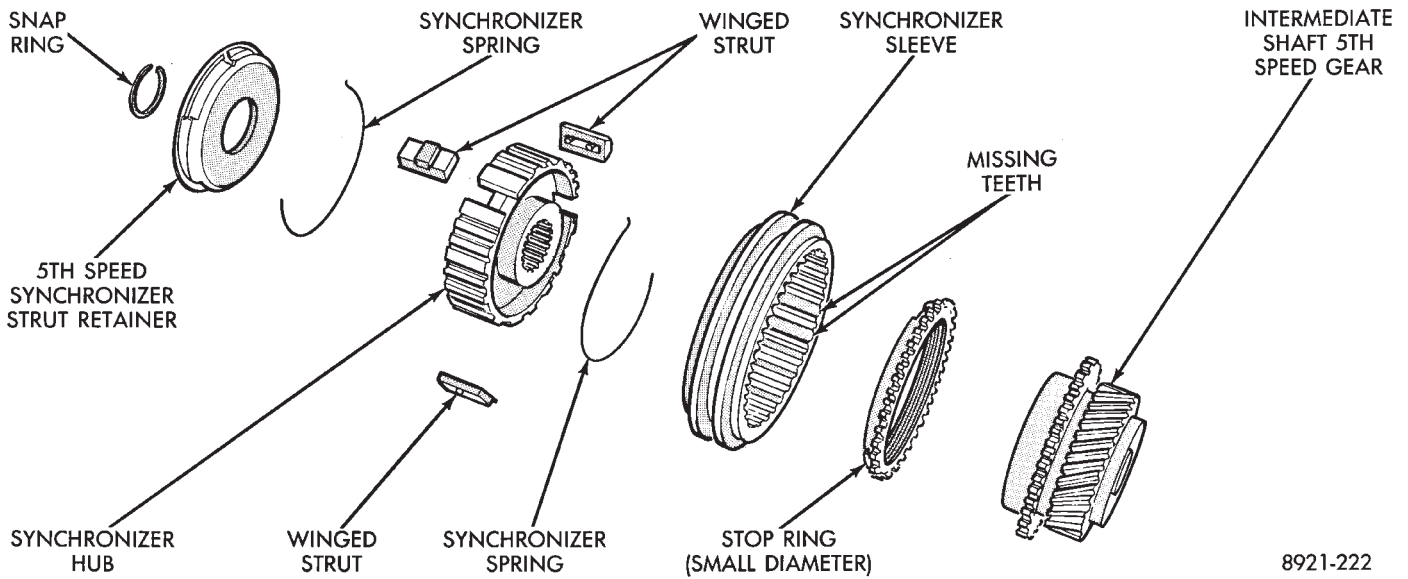

8921-222

Fig. 7 5th Speed Synchronizer

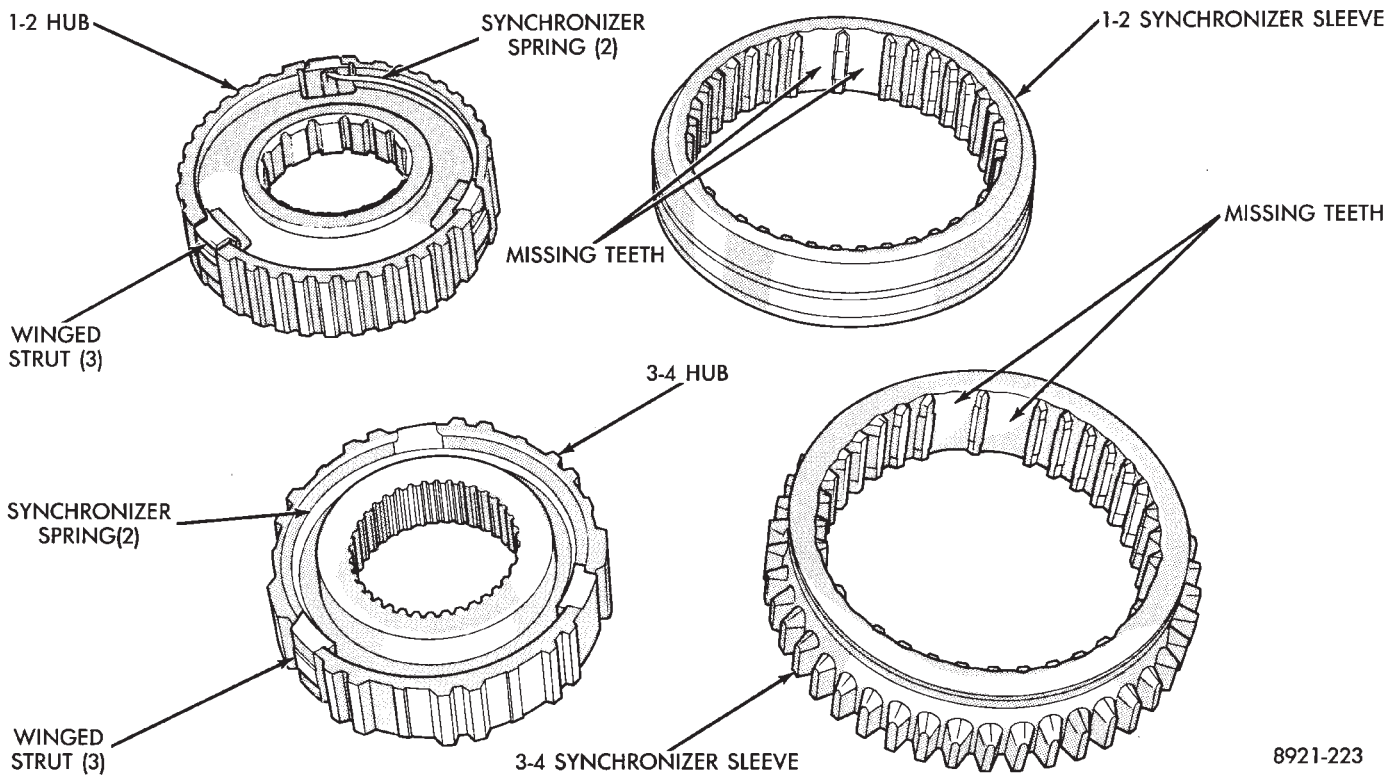
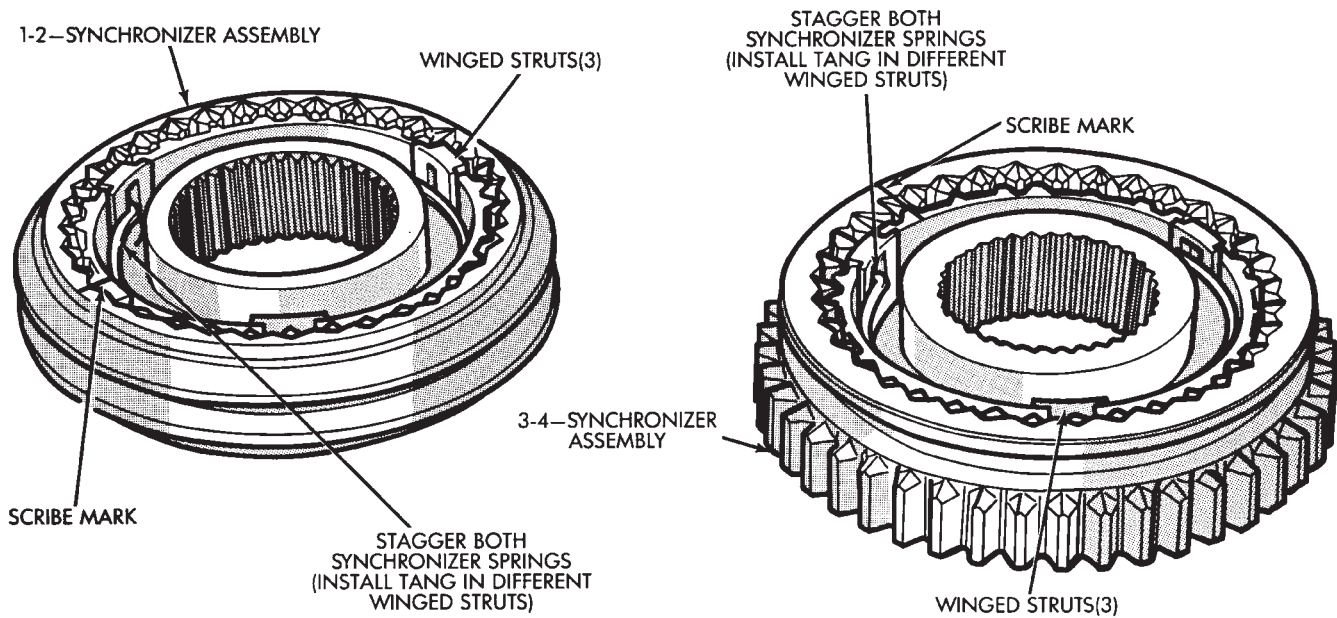

Fig. 8 Synchronizer Identification

CAUTION: 1-2 synchronizer assembly components must NOT be interchanged with any other synchronizer assembly, or with previous model years transaxles; they will NOT function correctly.



RB384

Fig. 9 Synchronizers

GEARSHIFT HOUSING

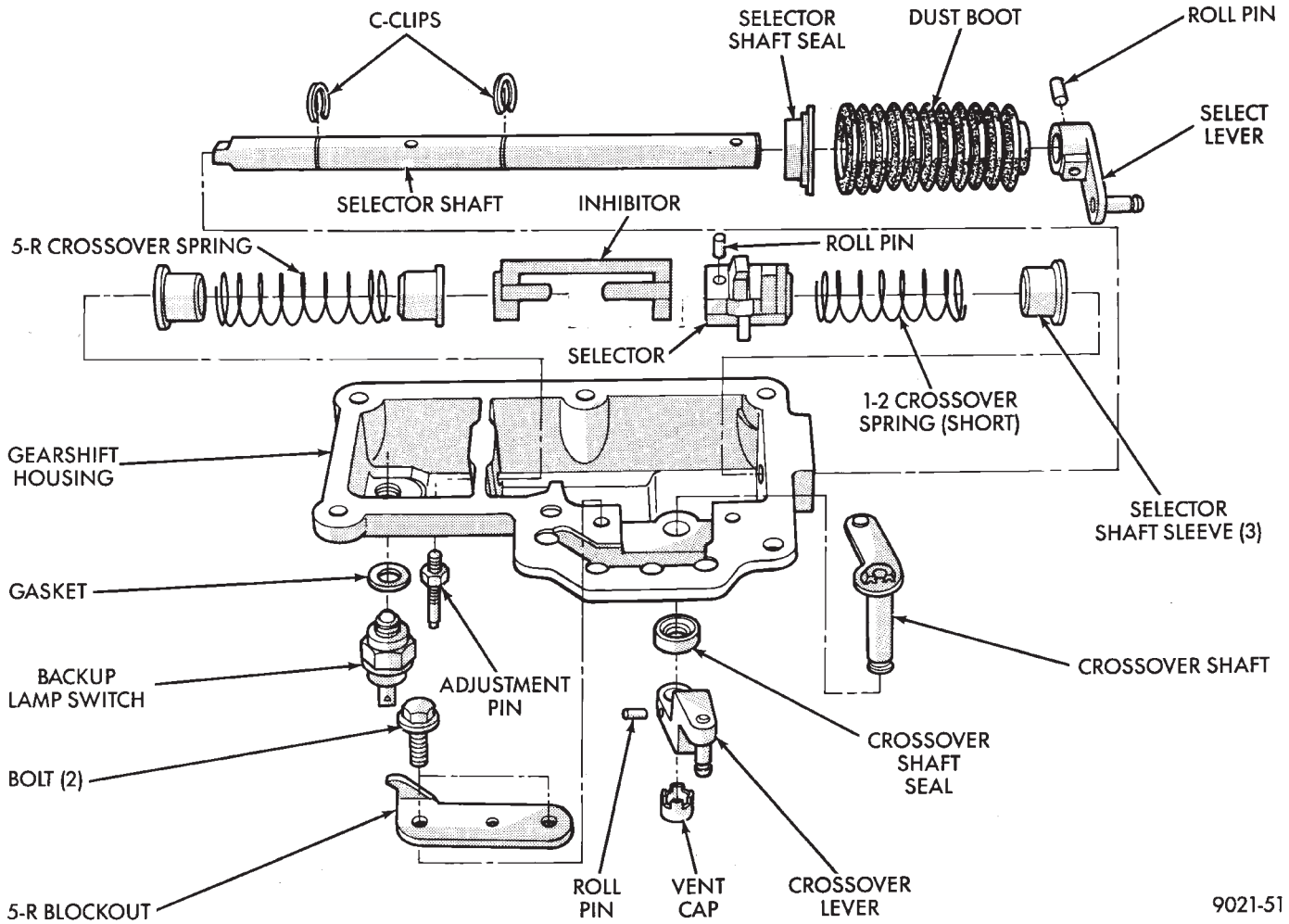

Fig. 1 Gearshift Housing Disassembled

Roll pin must be flush with top of lever.

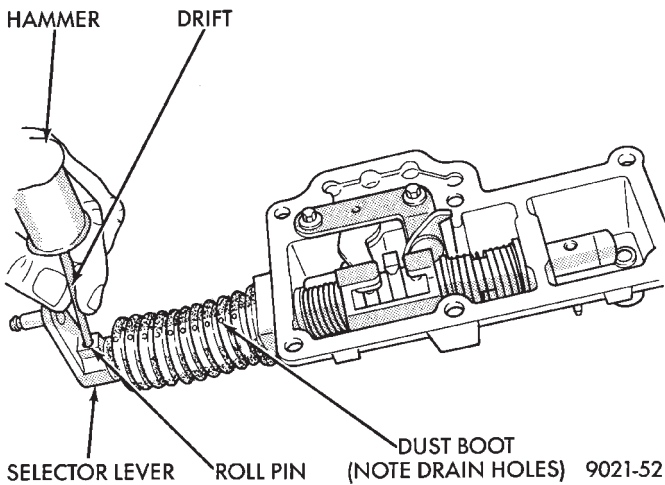

Fig. 2 Remove or Install Roll Pin and Lever

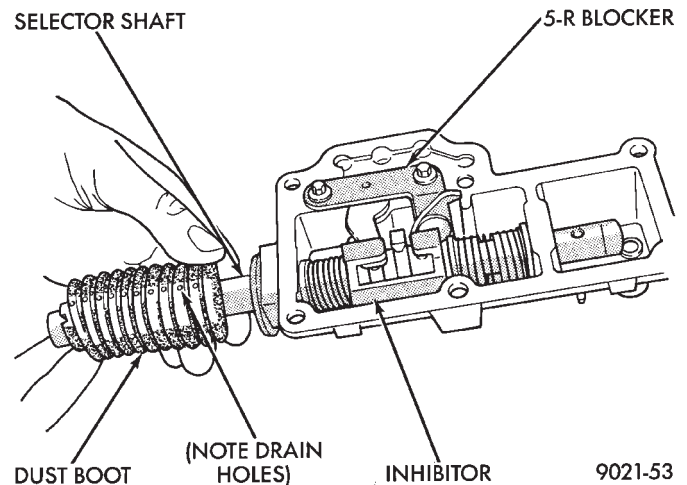
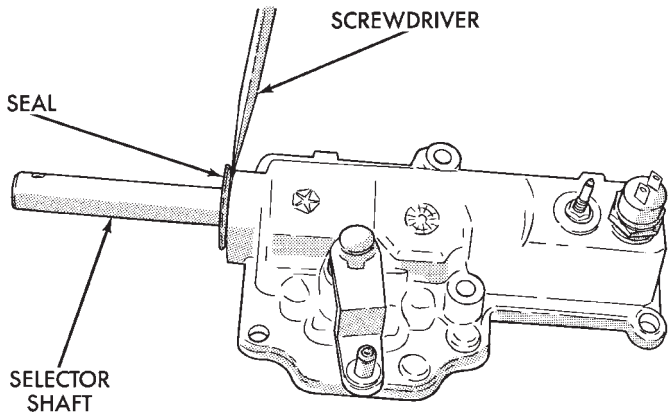
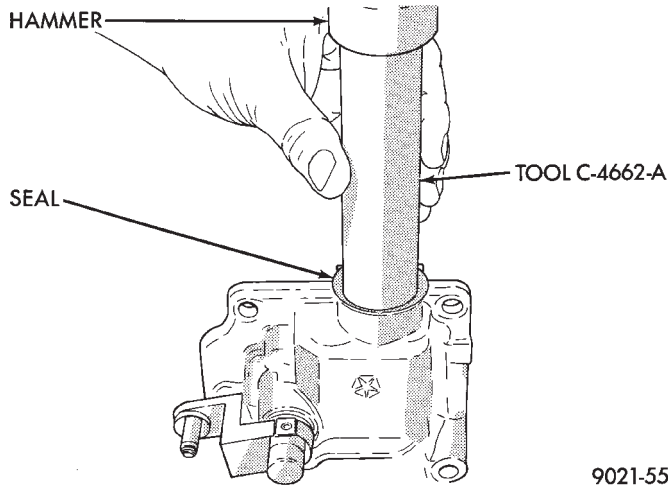

Fig. 3 Dust Boot



9021-54

Fig. 4 Remove Oil Seal



9021-55

Fig. 5 Install Oil Seal

The C-Clip grooves in the selector shaft will damage the oil seal. Install oil seal after selector shaft is installed. Always use a new oil seal when selector shaft is removed.

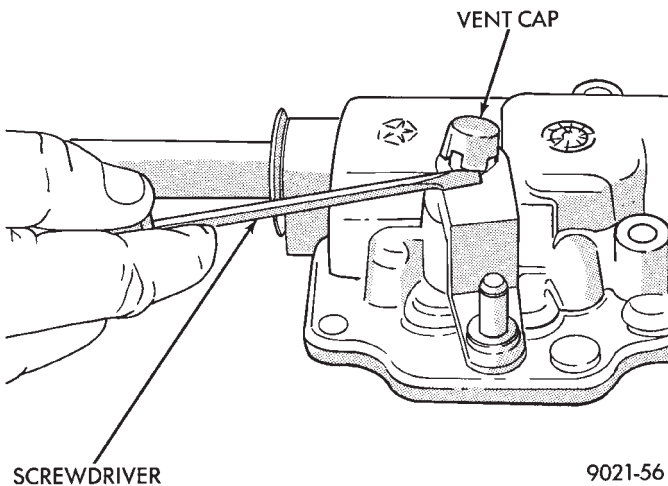

9021-56

Fig. 6 Remove Vent Cap

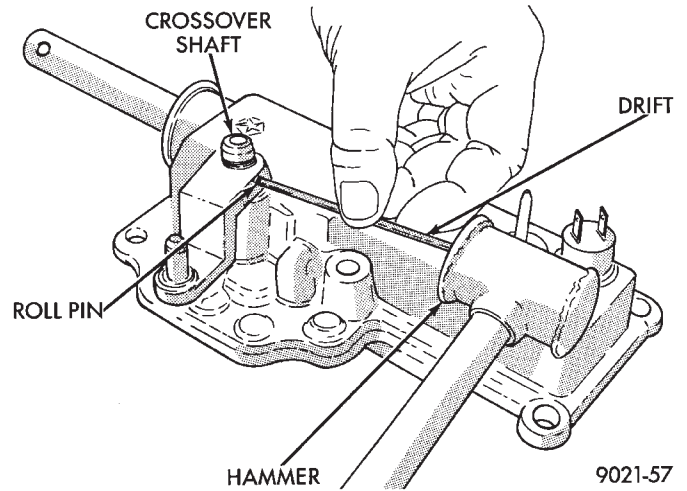

9021-57

Fig. 7 Crossover Shaft Roll Pin

Proper torque to the 5-R blocker attaching bolts is very important (Fig. 8).

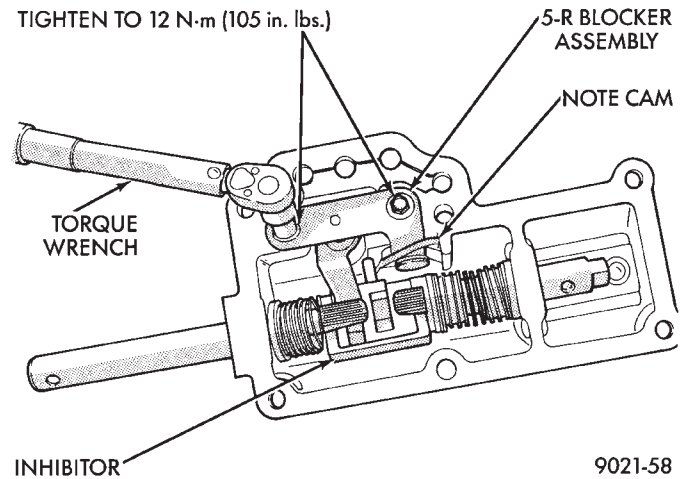

9021-58

Fig. 8 5-R Blocker Attaching Bolts

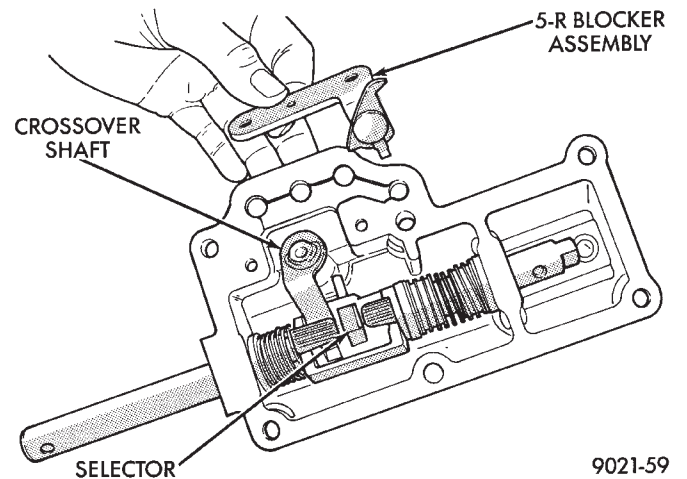

9021-59

Fig. 9 5-R Blocker Assembly

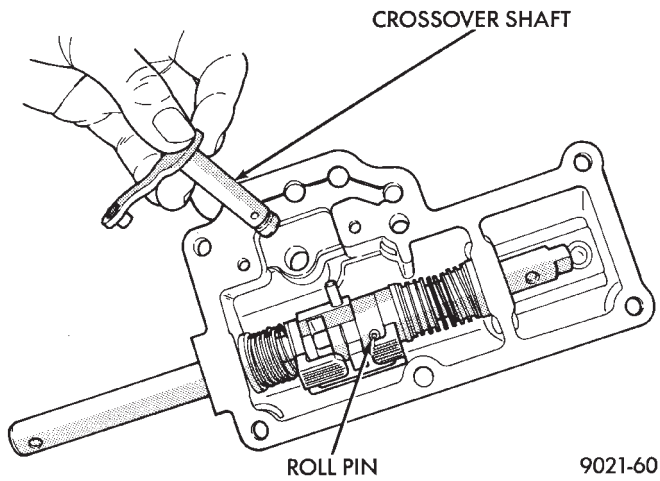

Fig. 10 Crossover Shaft

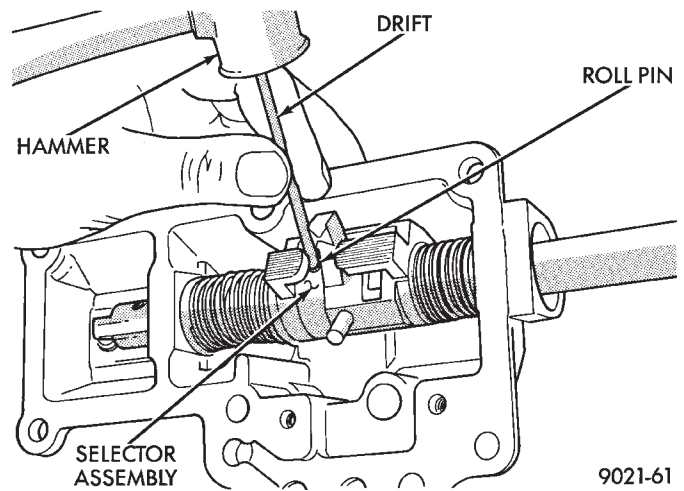

Fig. 13 Selector Assembly Roll Pin

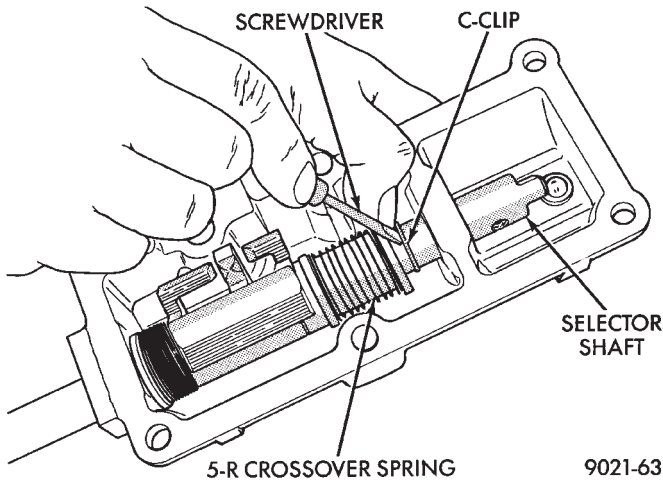

Fig. 11 Selector Shaft C-Clip

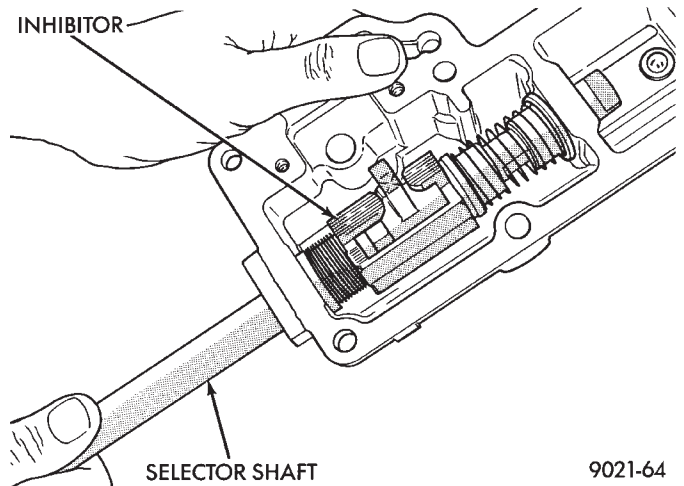

Fig. 14 Remove or Install Selector Shaft

For Disassembly: Drive roll pin out far enough to clear the selector shaft, but pin must remain in the selector so not to break the housing.

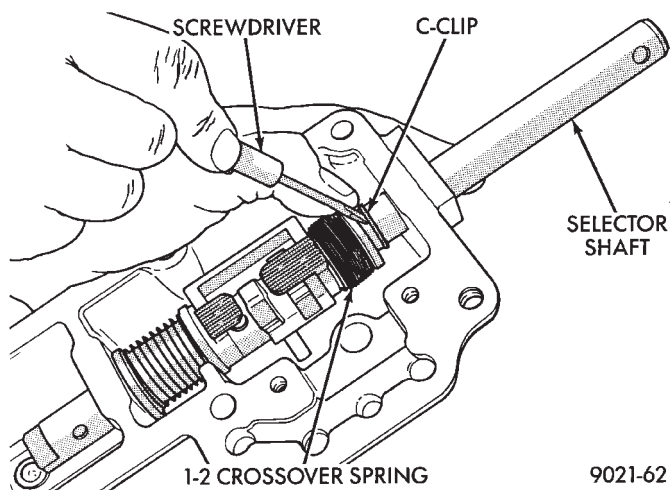

Fig. 12 Selector Shaft C-Clip

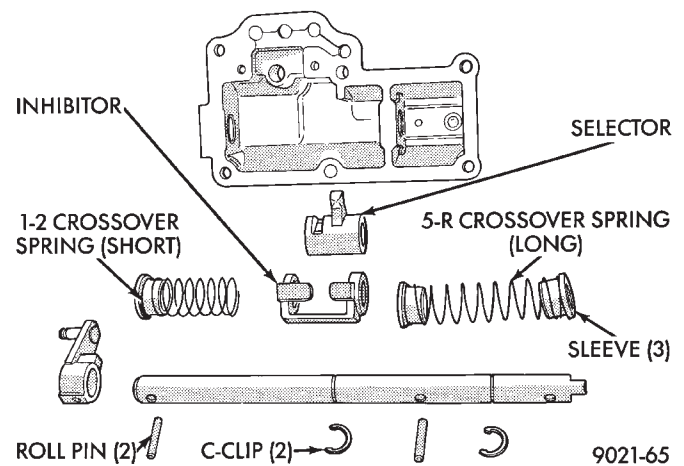

Fig. 15 Disassembled View

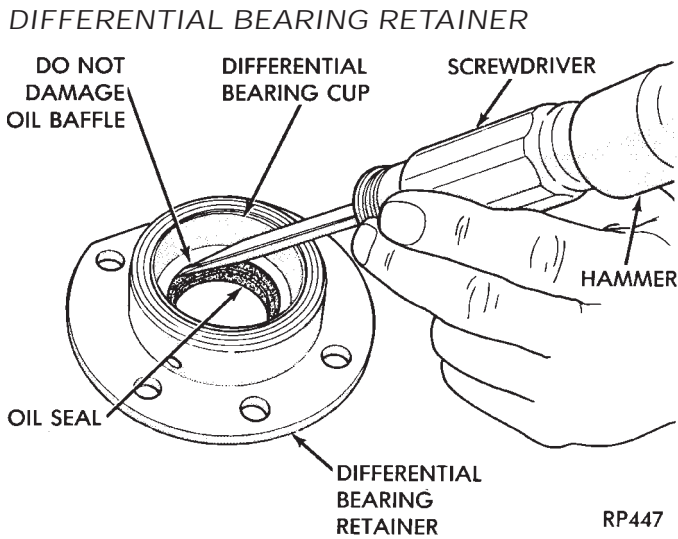

Fig. 1 Remove Differential Bearing Retainer Seal

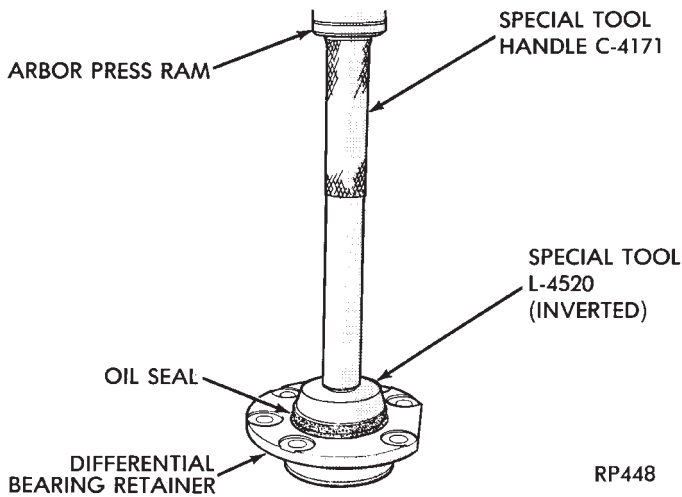

Fig. 2 Install Differential Bearing Retainer Seal

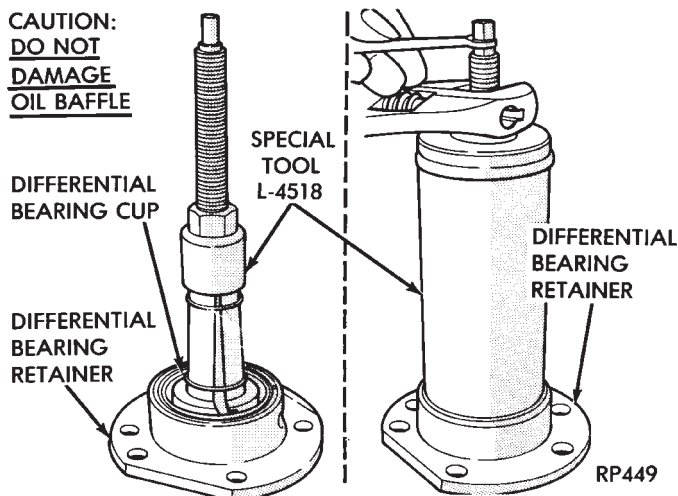

Fig. 3 Remove Differential Bearing Retainer Cup

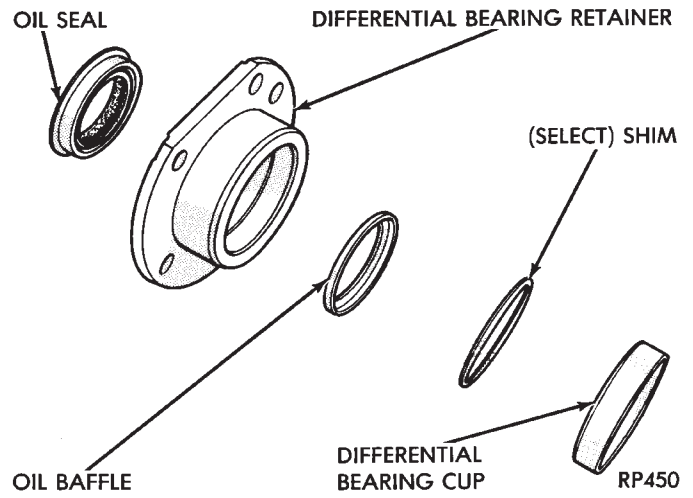

Fig. 4 Differential Bearing Retainer

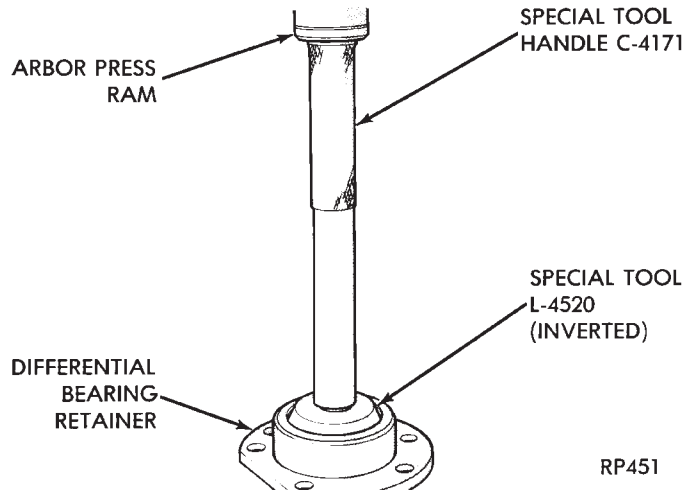

Fig. 5 Install Oil Baffle

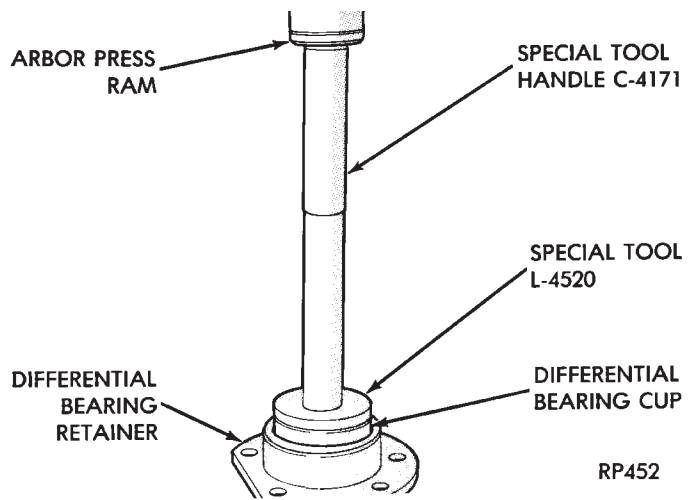

Fig. 6 Insert (Select) Shim and Differential Bearing Retainer Cup

EXTENSION HOUSING

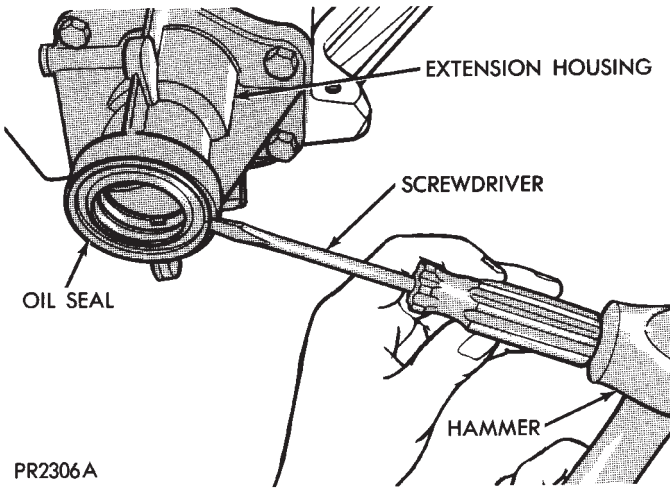

Fig. 1 Remove Extension Seal

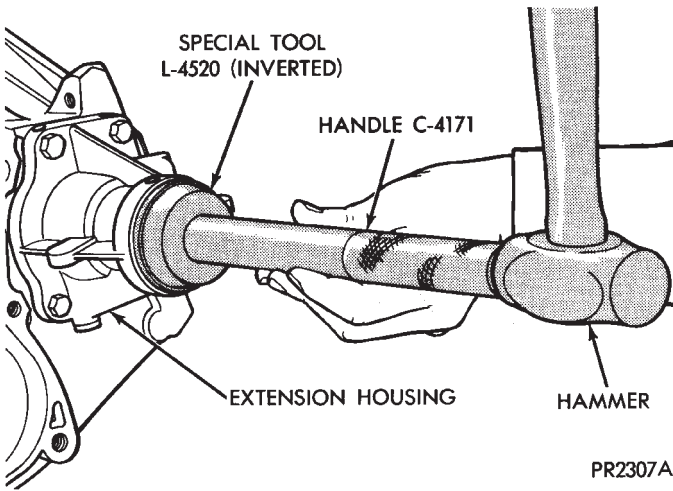

Fig. 2 Install New Seal into Extension

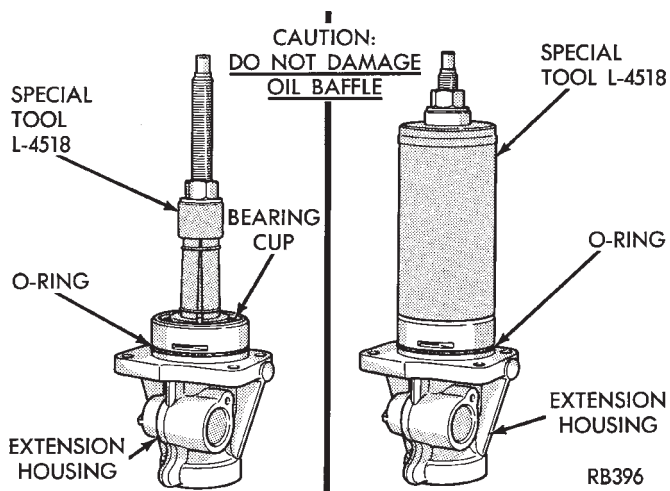

Fig. 3 Remove Extension Bearing Cup

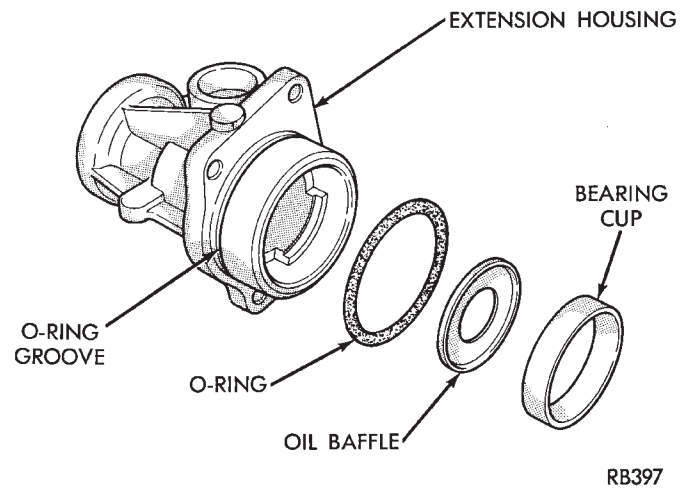

Fig. 4 Extension

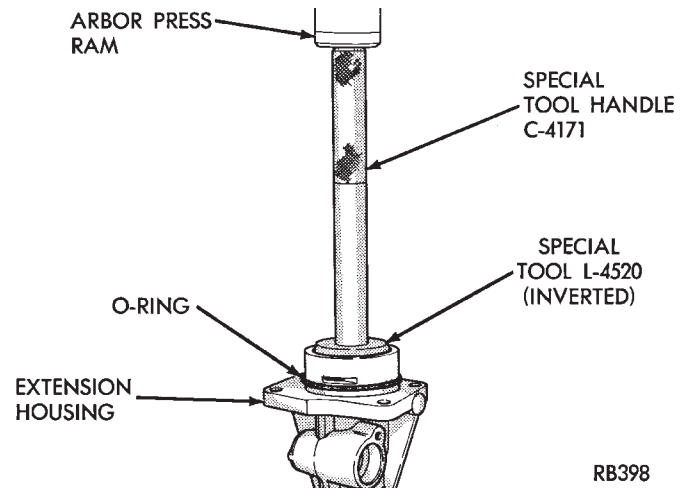

Fig. 5 Install Extension Oil Baffle

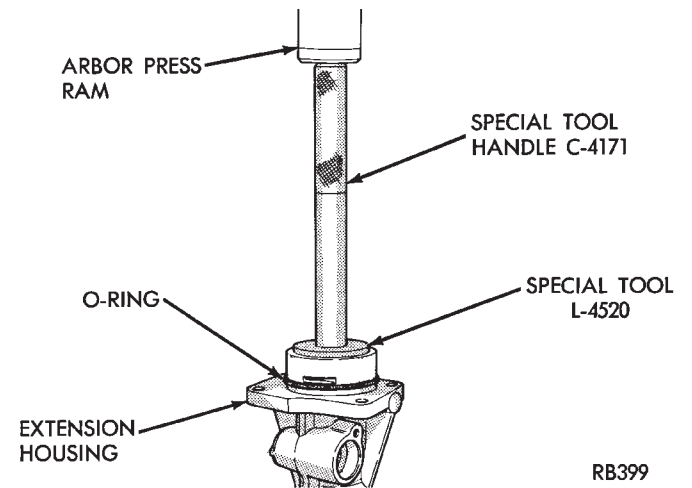

Fig. 6 Install Extension Bearing Cup



INPUT SHAFT

Shim thickness need only be determined if any of the following parts are replaced:

- Transaxle case
- Input shaft seal retainer
- Bearing retainer plate
- Rear end cover
- Input shaft
- Input shaft bearings

Refer to **Bearing Adjustment Procedure** in rear of this section to determine proper shim thickness for correct bearing end play and proper turning torque.

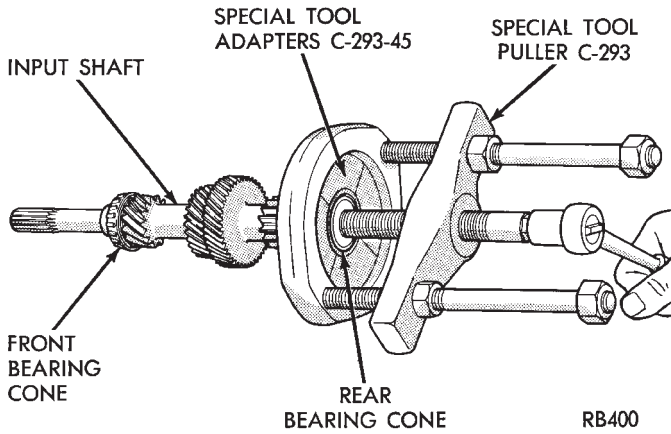

Fig. 1 Remove Input Shaft Rear Bearing Cone

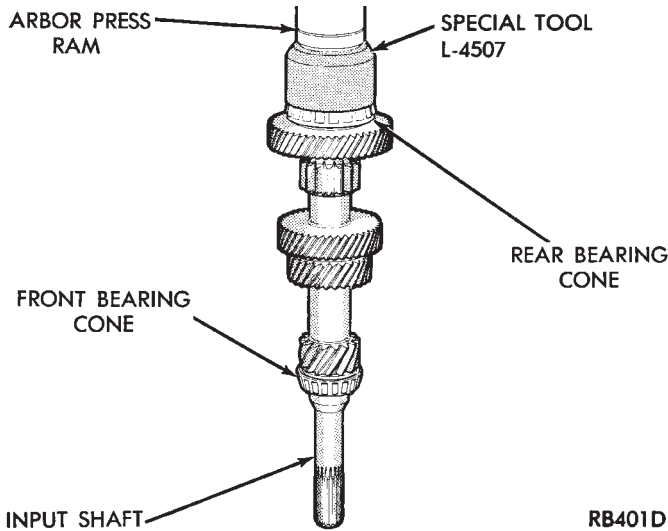

Fig. 2 Install Input Shaft Rear Bearing Cone

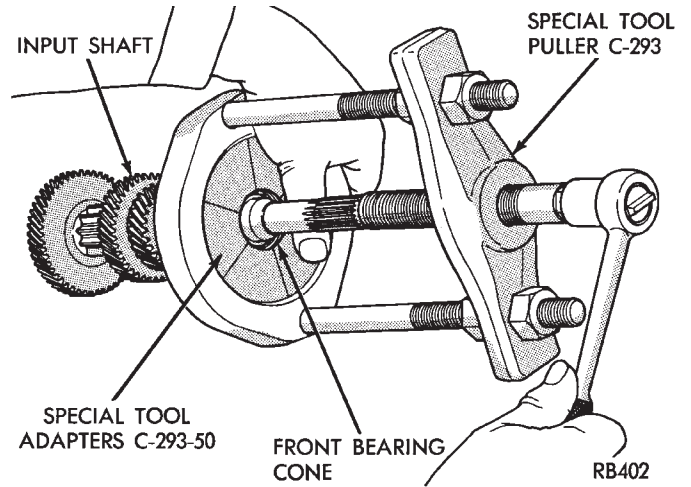

Fig. 3 Remove Input Shaft Front Bearing Cone

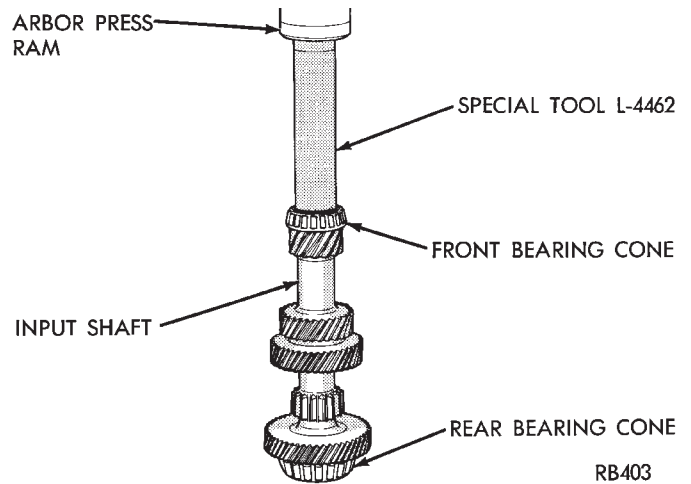

Fig. 4 Install Input Shaft Front Bearing Cone

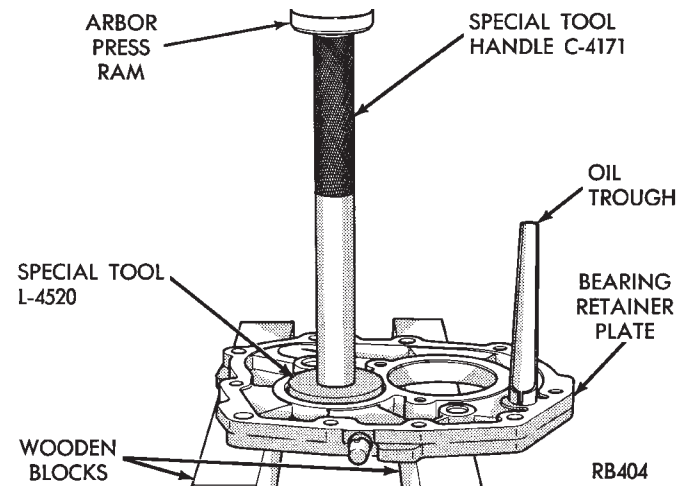

Fig. 5 Remove Input Shaft Rear Bearing Cup

CAUTION: Bolt on bearing support plate before installing input shaft rear bearing cup.

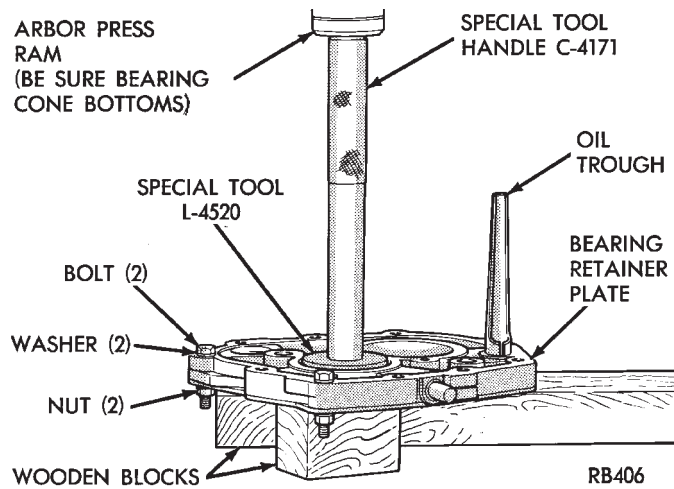

Fig. 6 Install Input Shaft Rear Bearing Cup

A-523 DIFFERENTIAL

Shim thickness need only be determined if any of the following parts are replaced:

- Transaxle case
- Differential bearing retainer
- Extension housing
- Differential case
- Differential bearings

Refer to **Bearing Adjustment Procedure** in rear of this section to determine proper shim thickness for correct bearing preload and proper bearing turning torque.

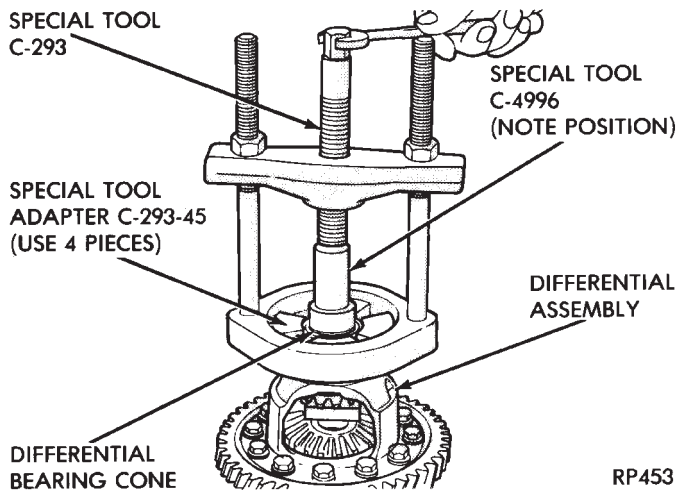

Fig. 1 Remove Differential Bearing Cone

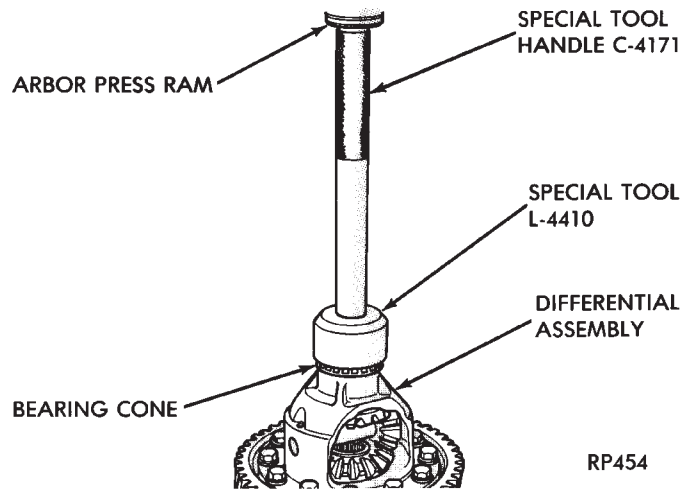

Fig. 2 Install Differential Bearing Cone

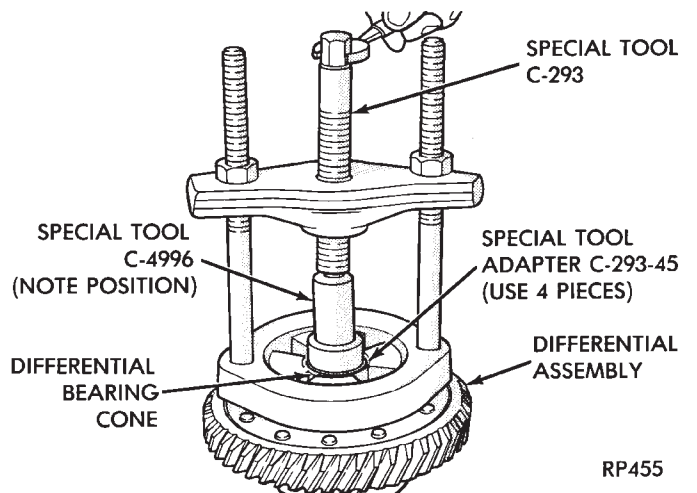

Fig. 3 Remove Differential Bearing Cone

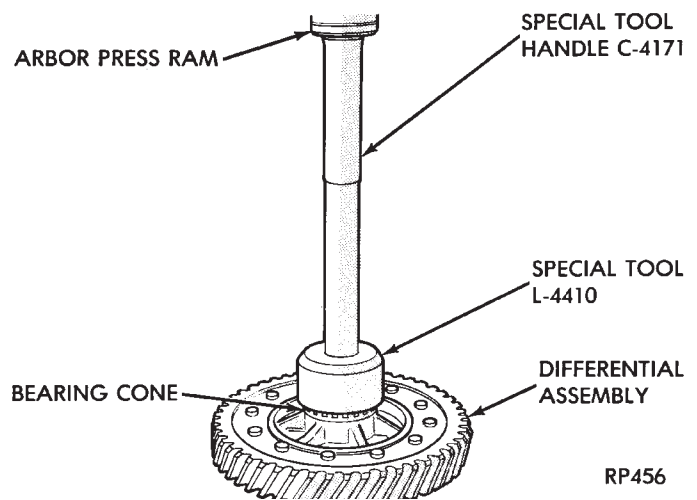

Fig. 4 Install Differential Bearing Cone

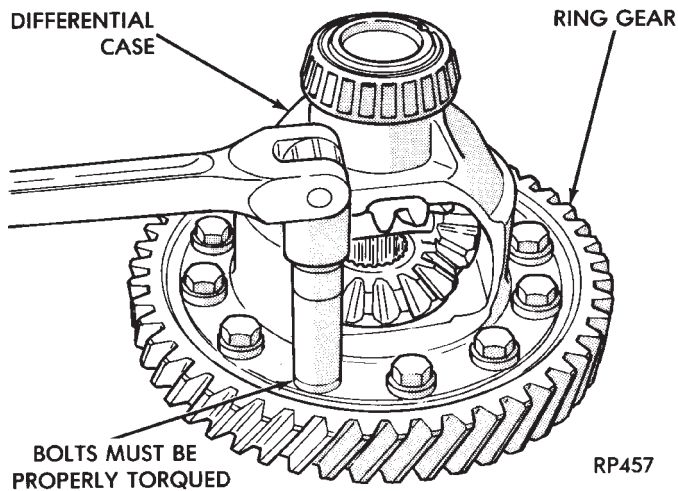

Fig. 5 Remove or Install Ring Gear Bolts and Ring Gear

CAUTION: Always install new ring gear bolts. Bolts must be properly torqued (See Tightening Reference).

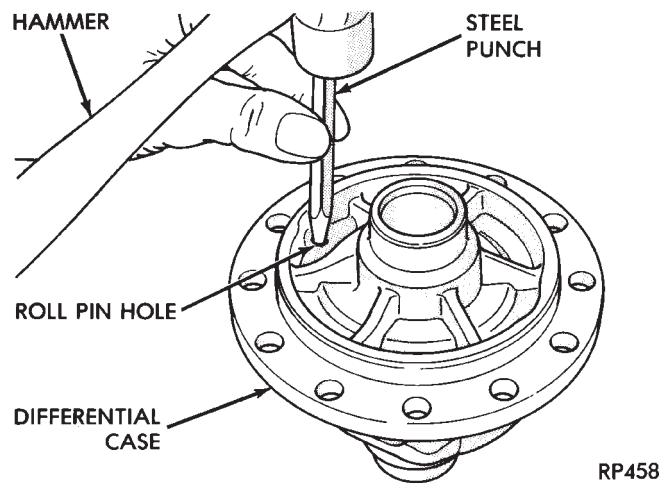

Fig. 6 Remove Pinion Shaft Roll Pin

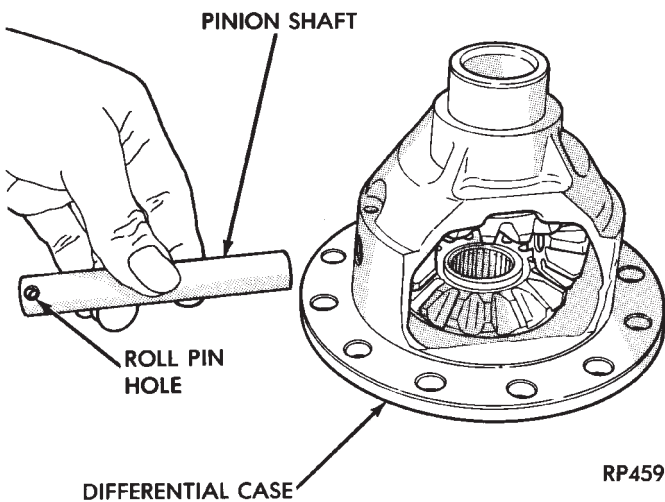

Fig. 7 Remove or Install Pinion Shaft

CAUTION: Side gear end play must be within .001 to .013 inch. Four select thrust washers are available: .032, .037, .042, and .047 inch.

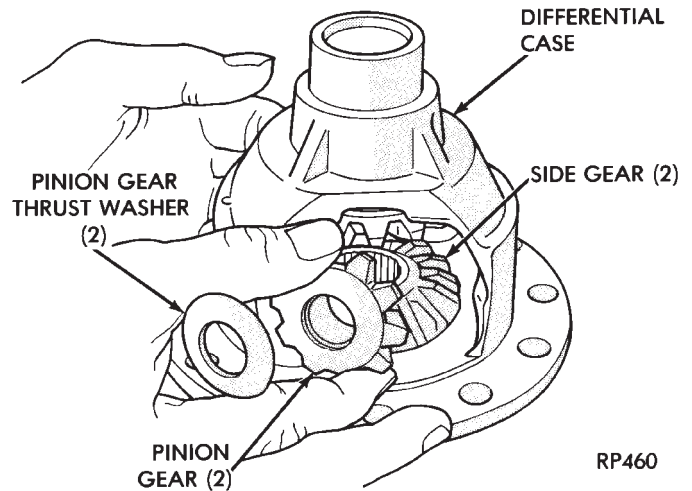

Fig. 8 Remove or Install Pinion Gears, Side Gears, and Thrust Washers by Rotating Side Gears to Opening in Case

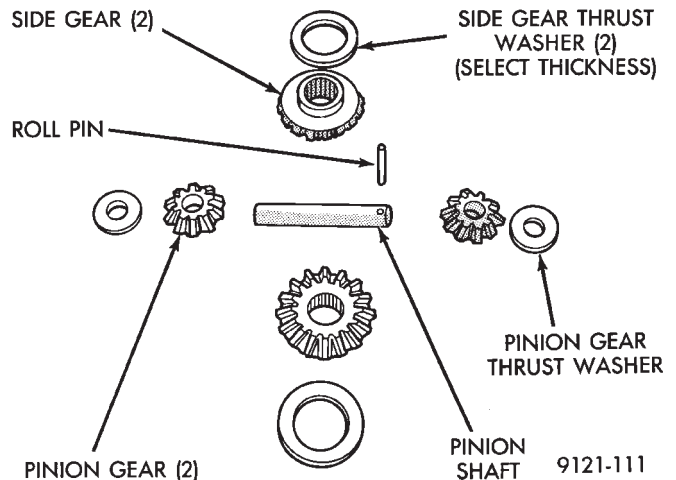

Fig. 9 Differential Gears

After assembling the differential side gears, pinion gears and pinion gears **with** the pinion gear washers but **without** the side gear thrust washers. Rotate the assembly two full revolutions both clockwise and counterclockwise.

Set up dial indicator as shown and record end play. Rotate side gear 90 degrees and record another end play. Again, rotate side gear 90 degrees and record a final end play.

Using the smallest end play recorded, shim that side gear to within .001 to .013 inch. The other side gear should be checked using the same procedure.

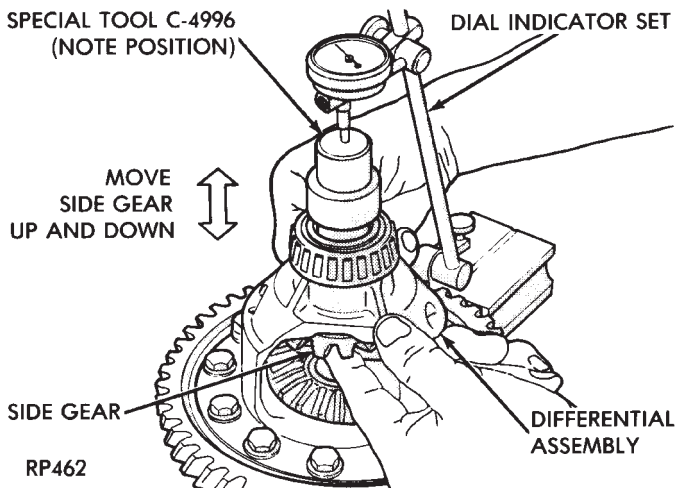

Fig. 10 Checking Side Gear End Play

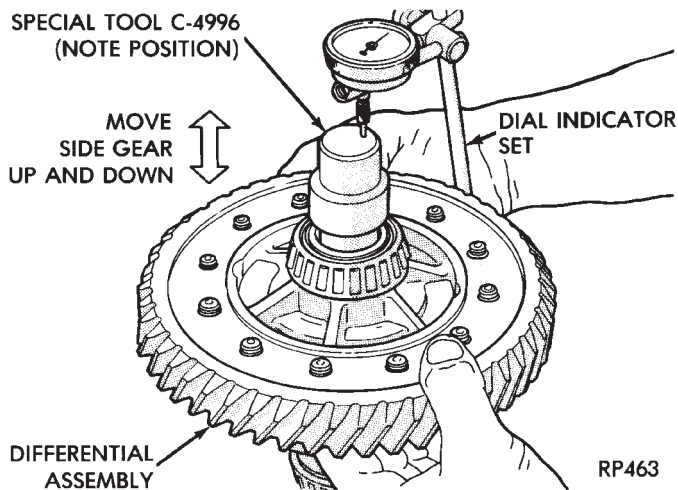

Fig. 11 Checking Side Gear End Play

BEARING ADJUSTMENT PROCEDURE

GENERAL RULES ON SERVICING BEARINGS

(1) Take extreme care when removing and installing bearing cups and cones. Use only an arbor press for installation, as a hammer may not properly align the bearing cup or cone. Burrs or nicks on the bearing seat will give a false end play reading while gauging for proper shims. Improperly seated bearing cups and cones are subject to low mileage failure.

(2) Bearing cups and cones should be replaced if they show signs of pitting or heat distress. If distress is seen on either the cup or bearing rollers, both cup and cone must be replaced.

(3) Bearing preload and drag torque specifications **must be maintained** to avoid premature bearing failures. Used (original) bearing may lose up to 50% of the original drag torque after break-in. **All bearing adjustments must be made with no other component interference or gear intermesh.**

(4) Replace bearings as a pair. For example, if one differential bearing is defective, replace both differen-

tial bearings. If one input shaft bearing is defective, replace both input shaft bearings.

(5) Bearing cones **must not** be reused if removed.

(6) Turning torque readings should be obtained while smoothly rotating in either direction (break-away reading is not indicative of the true turning torque).

(7) Replace oil baffle, if damaged.

INPUT SHAFT BEARING END PLAY ADJUSTMENT

(1) Using Tool C-4656 with Handle C-4171, press input shaft front bearing cup slightly forward in case. Then, using Tool C-4655 with Handle C-4171, press bearing cup back into case from the front. Properly position bearing cup, before checking input shaft end play (see input shaft front bearing cup replace in **Subassembly Recondition** section). **This step is not necessary if Tool C-4655 was previously used to install input shaft front bearing cup in the case. Also no input shaft shim has been installed since pressing cup into case.**

(2) Select a gauging shim which will give 0.025 to 0.254mm (.001 to .010 inch) end play. **SUGGESTION: Measure original shim from input shaft seal retainer and select a shim 0.254mm (.010 inch) thinner than original for the gauging shim.**

(3) Install gauging shim on bearing cup and install input shaft seal retainer.

CAUTION: The input shaft seal retainer is used to draw the input shaft front bearing cup the proper distance into the case bore during this step. Alternately tighten input shaft seal retainer bolts until input shaft seal retainer is bottomed against case. Tighten bolts to 28 N•m (21 ft. lbs.).

(4) Oil input shaft bearings with SAE 5W-30 engine oil and install input shaft in case. Install bearing retainer plate with input shaft rear bearing cup pressed in and bearing support plate installed. Tighten all bolts and nuts to 28 N•m (21 ft. lbs.).

(5) Position dial indicator to check input shaft end play. Apply moderate load, by hand, to input shaft splines (Fig. 1). Push toward rear while rotating input shaft back and forth a number of times to settle out bearings. Zero dial indicator. Pull input shaft toward the front while rotating input shaft back and forth a number of times to settle out bearings. Record end play.

(6) The **shim** required for proper bearing end play is the total of the **gauging shim thickness, plus end play, minus (constant) end play of 0.051mm (.002 inch)**. Combine shims, if necessary, to obtain a shim within .04mm (.0016 inch) of the required shim (see Shim Chart for proper shim).

(7) Remove input shaft seal retainer and gauging shim. Install shim(s) selected in step (6) and reinstall

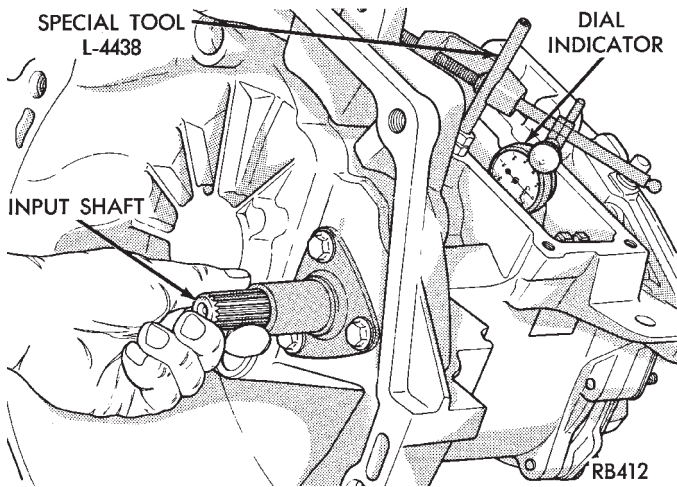

INPUT SHAFT SHIM CHART

mm	inch
.62	.024
.66	.026
.70	.028
.74	.029
.78	.031
.82	.032
.86	.034
.90	.035
.94	.037
.98	.039
1.02	.040
1.06	.042
1.10	.043
1.14	.045
1.18	.046
1.22	.048
1.26	.050
1.30	.051
1.34	.053
1.36 (.66 + .70)	.054
1.40 (.66 + .74)	.055
1.44 (.70 + .74)	.057
1.48 (.70 + .78)	.059
1.52 (.74 + .78)	.060
1.56 (.74 + .82)	.061
1.60 (.78 + .82)	.063
1.64 (.78 + .86)	.065
1.68 (.82 + .86)	.066
1.72 (.82 + .90)	.068
1.76 (.86 + .90)	.069

Fig. 1 Checking Input Shaft Bearing End Play to Determine Shim Thickness

input shaft seal retainer with a 1/16 inch bead of MOPAR® Gasket Maker, Loctite 518, or equivalent for a gasket. Record end play. Observe the **CAUTION** in step (3). Tighten input shaft seal retainer bolts to 28 N•m (21 ft. lbs.).

(8) To verify that a preload condition does not exist, use Special Tool L-4508 and an inch-pound torque wrench to check input shaft turning torque (Fig. 2). **The turning torque should be less than 5 in. lbs.**

CAUTION: Step (1) **MUST** be repeated every time a thinner shim is installed. This will assure that the input shaft bearing cup is pressed the proper distance into the case. If the turning torque is too high, install a .04mm (.0016 inch) thinner shim.

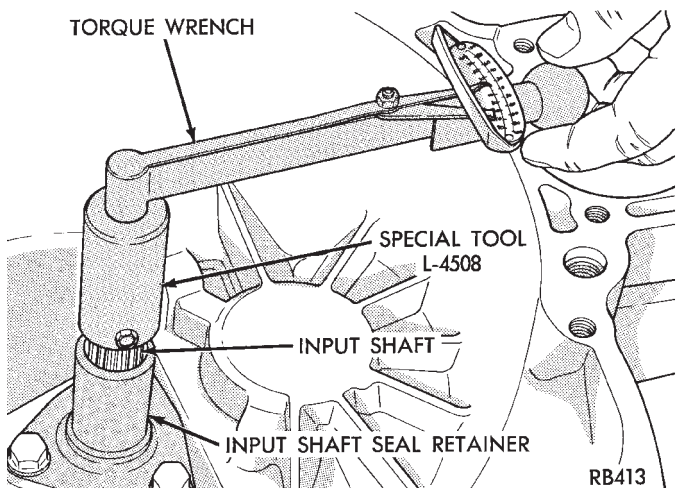

Fig. 2 Checking Input Shaft Bearing Turning Torque

(9) Recheck input shaft turning torque. Repeat step (8) until the proper bearing turning torque is obtained. Observe **CAUTION** in step (8).

9121-19

DIFFERENTIAL BEARING PRELOAD ADJUSTMENT

(1) Remove bearing cup and existing shim from differential bearing retainer. (See Differential Bearing Retainer in **Subassembly Recondition** section).

(2) Select a gauging shim which will give 0.025 to 0.254mm (.001 to .010 inch) end play. **SUGGESTION: Measure original shim from differential bearing retainer and select a shim 0.381mm (.015 inch) thinner than original for the gauging shim.** Install gauging shim in differential bearing retainer and press in bearing cup. **Installation of oil baffle is not necessary when checking differential assembly end play.**

(3) Oil differential bearings with SAE 5W-30 engine oil and install differential assembly in transaxle case. Check extension housing O-ring for damage (replace if necessary). Add a 1/16 inch bead of MOPAR® Gasket Maker, Loctite 518, or equivalent to extension flange. Install extension housing and differential bearing retainer. Torque bolts (see Tightening Reference).

(4) Position transaxle with bell housing facing down on workbench with C-clamps. Position dial indicator.

(5) Apply a medium load to differential with Tool C-4995 and a T-Handle, in the downward direction. Roll differential assembly back and forth a number

of times. This will settle the bearings. Zero dial indicator. To obtain end play readings, apply a medium load in the upward direction while rolling differential assembly back and forth a number of times to settle out the bearings (Fig. 3). Record end play.

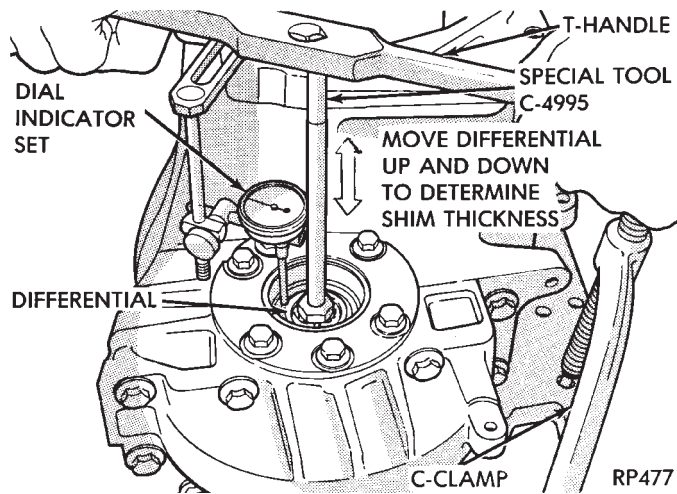

Fig. 3 Checking Differential Bearing End Play to Determine Shim Thickness

(6) The **Shim** required for proper bearing preload is the **total of the gauging shim thickness, plus end play, plus (constant) preload of 0.254mm (.010 inch)**. Combine shims, if necessary, to obtain a shim within .05mm (.002 inch) of the required shim (see Shim Chart for proper shims).

(7) Remove differential bearing retainer. Remove bearing cup and gauging shim. Properly install oil baffle. **Be sure oil baffle is not damaged.** Install shim(s) selected in step (6) and press in the bearing cup into differential bearing retainer.

(8) Using a 1/16 inch bead of MOPAR® Gasket Maker, Loctite 518, or equivalent for gasket, install differential bearing retainer. Torque all bolts (See Tightening Reference).

(9) Using Special Tool C-4995 and an inch-pound torque wrench, check turning torque of the differential assembly in clockwise and counterclockwise directions (Fig. 4). **The turning torque should be 9 to 14 in. lbs. for new bearings or a minimum of 6 in. lbs. for used bearings. If the turning torque is too high, install a .05mm (.002 inch) thinner shim. If the turning torque is too low, install a .05mm (.002 inch) thicker shim.**

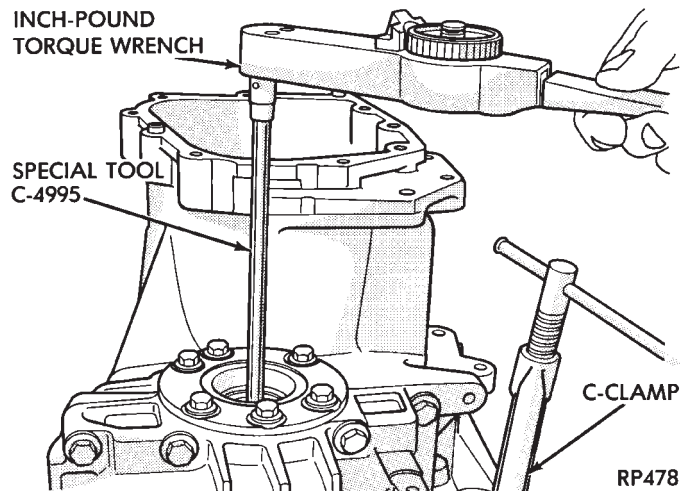

Fig. 4 Checking Differential Bearing Turning Torque

(10) Recheck turning torque. Repeat Step (9) until the proper turning torque is obtained.

DIFFERENTIAL BEARING SHIM CHART

Required Shim Combination		Total Thickness
mm		inch
.50020
.75030
.80032
.85034
.90035
.95037
1.00039
1.05041
1.10	(.50 + .60)043
1.15	(.50 + .65)045
1.20	(.50 + .70)047
1.25	(.50 + .75)049
1.30	(.50 + .80)051
1.35	(.50 + .85)053
1.40	(.50 + .90)055
1.45	(.50 + .95)057
1.50	(.50 + 1.00)059
1.55	(.50 + 1.05)061
1.60	(1.00 + .60)063
1.65	(1.00 + .65)065
1.70	(1.00 + .70)067
1.75	(1.00 + .75)069
1.80	(1.00 + .80)071
1.85	(1.00 + .85)073
1.90	(1.00 + .90)075
1.95	(1.00 + .95)077
2.00	(1.00 + 1.00)079
2.05	(1.00 + 1.05)081
2.10	(1.05 + 1.05)083

THREE SPEED TORQUEFLITE AUTOMATIC TRANSAXLE

INDEX

	page		page
Accumulator-Recondition	64	Lockup Solenoid Wiring Connector	37
Aluminum Thread Repair	45	Low/Reverse (Rear) Servo-Recondition	63
Band Adjustment	44	Neutral Starting and Back-Up Lamp Switch	44
Bearing Adjustment Procedures	79	Oil Cooler Flow Check	45
Clutch and Servo Air Pressure Tests	40	Oil Coolers and Tubes Reverse Flushing	45
Differential Repair	73	Oil Pump-Recondition	59
Distance Sensor Pinion Gear	44	Output Shaft Repair	70
Fluid and Filter Change	37	Parking Pawl	69
Fluid Drain and Refill	37	Pump Oil Seal-Replacement	58
Fluid Leakage-Transaxle Torque Converter Housing Area	40	Rear Clutch-Recondition	61
Fluid Level and Condition	36	Road Test	37
Front Clutch-Recondition	59	Selection of Lubricant	37
Front Planetary & Annulus Gear-Recondition	62	Special Additives	37
Gearshift Linkage Adjustment	43	Throttle Pressure Linkage Adjustment	43
General Information	32	Torqueflite Diagnosis and Tests	33
Governor	45	Transaxle and Torque Converter Removal	46
Hydraulic Control Pressure Adjustments	44	Transaxle Assembly (Subassembly Installation)	54
Hydraulic Pressure Tests	38	Transaxle Disassembly (Subassembly Removal)	48
Kickdown Servo (Controlled Load)-Recondition	64	Transfer Shaft Repair	65
		Valve Body Recondition	54

GENERAL INFORMATION

Safety goggles should be worn at all times when working on these transaxles.

This transaxle combines a torque converter, fully automatic three speed transmission, final drive gearing, and differential into a compact front-wheel-drive system. The unit is basically a "Metric" design. The identification markings and usage of the transaxle are charted in Diagnosis and Tests.

Transaxle operation requirements are different for each vehicle and engine combination and some internal parts will be different to provide for this. Therefore, when replacing parts, refer to the seven digit part number stamped on rear of the transaxle oil pan flange.

Within this transaxle, there are three primary areas:

- (1) Main center line plus valve body.
- (2) Transfer shaft center line (includes governor and parking sprag).
- (3) Differential center line. Center distances between the main rotating parts in these 3 areas are held precisely to maintain a low noise level through smooth accurate mesh of the gears connecting the center lines.

The torque converter, transaxle area, and differential are housed in an integral aluminum die casting. **The "differential oil sump" is common with the "transaxle sump." Separate filling of the differential is NOT necessary.**

The torque converter is attached to the crankshaft through a flexible driving plate. Cooling of the converter is accomplished by circulating the transaxle

fluid through an oil-to-water type cooler located in the radiator side tank and/or an oil-to air heat exchanger. The torque converter assembly is a sealed unit that cannot be disassembled.

The transaxle fluid is filtered by an internal filter attached to the lower side of the valve body assembly.

Engine torque is transmitted to the torque converter then, through the input shaft to multiple-disc clutches in the transaxle. The power flow depends on the application of the clutches and bands. Refer to "Elements in Use Chart" in Diagnosis and Tests section. The transaxle consists of two multiple-disc clutches, an overrunning clutch, two servos, a hydraulic accumulator, two bands, and two planetary gear sets. This provides three forward ratios and a reverse ratio. The common sun gear of the planetary gear sets is connected to the front clutch by a driving shell. The drive shell is splined to the sun gear and to the front clutch retainer. The hydraulic system consists of an oil pump, and a single valve body which contains all of the valves except the governor valves. The transaxle sump and differential sump are both vented through the "dipstick". Output torque from the main center line is delivered through helical gears to the "transfer shaft." This gear set is a factor of the final drive (axle) ratio. The shaft also carries the governor and parking sprag. An integral helical gear on the transfer shaft drives the differential ring gear. The final drive gearing is completed with one of three gear sets producing overall top gear ratios of 2.78, 3.02, or 3.22 depending on model and application.

LOCKUP TORQUE CONVERTER

The lockup torque converter is standard on all vehicles. The lockup mode is activated only in direct drive and is controlled by the engine electronics. A lockup solenoid on the valve body, is powered by the engine controller to activate torque converter lockup.

HYDRAULIC CONTROL SYSTEM

The hydraulic control circuits show the position of the various valves with color coded passages to indicate those under hydraulic pressure for all operations of the transaxle.

The hydraulic control system makes the transaxle fully automatic, and has four important functions to perform. In a general way, the components of any automatic control system may be grouped into the following basic groups:

The pressure supply system, the pressure regulating valves, the flow control valves, the clutches, and band servos.

Taking each of these basic groups or systems in turn, the control system may be described as follows:

PRESSURE SUPPLY SYSTEM

The pressure supply system consists of an oil pump driven by the engine through the torque converter. The single pump furnishes pressure for all the hydraulic and lubrication requirements. **Oil pump housing assemblies are available with preselected pump gears.**

PRESSURE REGULATING VALVES

The pressure regulating valve controls line pressure dependent on throttle opening. The governor valve transmits regulated pressure to the valve body (in conjunction with vehicle speed) to control upshift and downshift.

The throttle valve transmits regulated pressure to the transaxle (dependent on throttle position) to control upshift and downshift.

FLOW CONTROL VALVES

The manual valve provides the different transaxle drive ranges as selected by the vehicle operator.

The 1-2 shift valve automatically shifts the transaxle from first to second or from second to first, depending on the vehicle operation.

The 2-3 shift valve automatically shifts the transaxle from second to third or from third to second depending on the vehicle operation.

The kickdown valve makes possible a forced downshift from third to second, second to first, or third to first (depending on vehicle speed). This can be done by depressing the accelerator pedal past the detent "feel" near wide open throttle.

The shuttle valve has two separate functions and performs each independently of the other. The first is that of providing fast release of the kickdown band,

and smooth front clutch engagement when the driver makes a "lift-foot" upshift from second to third. The second function of the shuttle valve is to regulate the application of the kickdown servo and band when making third to second kickdown.

The by-pass valve provides for smooth application of the kickdown band on 1-2 upshifts.

The lockup solenoid allows for the electronic control of the lockup clutch inside the torque converter. It also unlocks the torque converter at closed throttle, during engine warm-up, and during part-throttle acceleration.

The switch valve directs oil to apply the lockup clutch in one position and releases the lockup clutch in the other position.

CLUTCHES, BAND SERVOS, AND ACCUMULATOR

The front and rear clutch pistons, and both servo pistons are moved hydraulically to engage the clutches and apply the bands. The pistons are released by spring tension when hydraulic pressure is released. On the 2-3 upshift, the kickdown servo piston is released by spring tension and hydraulic pressure.

The accumulator controls the hydraulic pressure on the apply side of the kickdown servo during the 1-2 upshift; thereby, cushioning the kickdown band application at any throttle position.

GEARSHIFT AND PARKING LOCK CONTROLS

The transaxle is controlled by a "lever type" gearshift incorporated within the steering column. The control has six selector lever positions: P (park), R (reverse), N (neutral), and D (drive), 2 (second), and 1 (first). The parking lock is applied by moving the selector lever past a gate to the "P" position. **Do not apply the parking lock until the vehicle has stopped; otherwise, a severe ratchet noise will occur.**

TORQUEFLITE DIAGNOSIS AND TESTS

Automatic transaxle malfunctions may be caused by four general conditions:

- (1) Poor engine performance
- (2) Improper adjustments
- (3) Hydraulic malfunctions
- (4) Mechanical malfunctions

Diagnosis of these problems should always begin by checking the easily accessible variables: fluid level and condition, gearshift cable adjustment, and throttle pressure cable adjustment. Then perform a road test to determine if the problem has been corrected or that more diagnosis is necessary. If the problem exists after the preliminary tests and corrections are completed, hydraulic pressure tests should be performed.

DIAGNOSIS GUIDE-VEHICLE WILL NOT MOVE

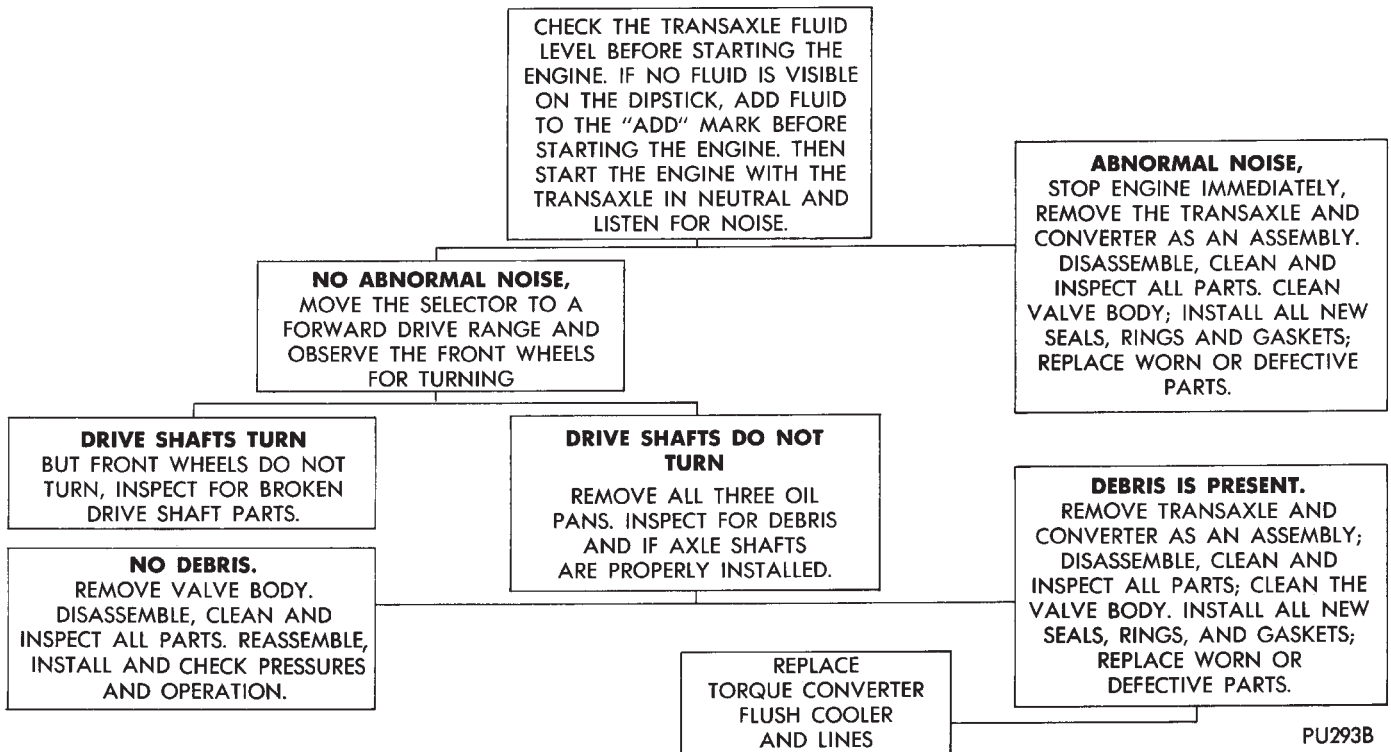

DIAGNOSIS GUIDE-FLUID LEAKS

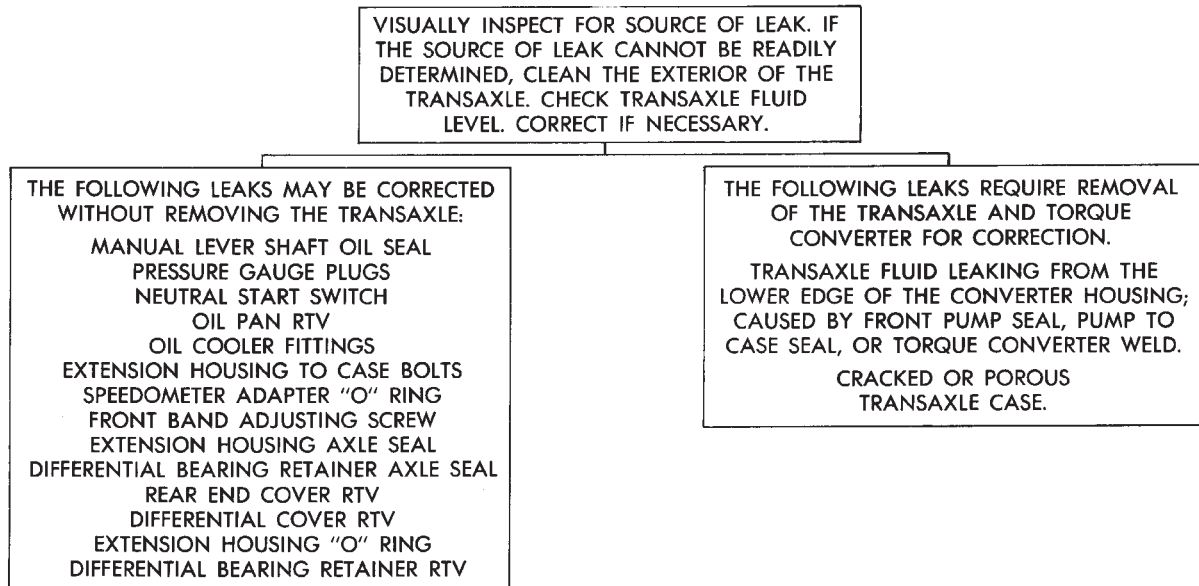



POSSIBLE CAUSE

Engine performance.
 Overrunning clutch inner race damaged.
 Overrunning clutch worn, broken or seized.
 Planetary gear sets broken or seized.
 Rear clutch dragging.
 Worn or faulty rear clutch.
 Insufficient clutch plate clearance.
 Faulty cooling system.
 Kickdown band adjustment too tight.
 Hydraulic pressure too high.
 High fluid level.
 Worn or faulty front clutch.
 Kickdown servo band or linkage malfunction.
 Governor malfunction.
 Worn or broken reaction shaft support seal rings.
 Governor support seal rings broken or worn.
 Driveshaft(s) bushing(s) damaged.
 Overrunning clutch not holding.
 Kickdown band out of adjustment.
 Incorrect throttle linkage adjustment.
 Engine idle speed too low.
 Aerated fluid.
 Worn or broken input shaft seal rings.
 Faulty oil pump.
 Oil filter clogged.
 Incorrect gearshift control linkage adjustment.
 Low fluid level.
 Low-reverse servo, band or linkage malfunction.
 Valve body malfunction or leakage.
 Low-reverse band worn out.
 Hydraulic pressures too low.
 Engine idle speed too high.
 Stuck switch valve.
 Low-reverse band misadjusted.

CONDITION	1	2	3	4	5	6	7	8	9	10	11	12	13	14	15	16	17	18	19	20	21	22	23	24	25	26	27	28	29	30	31	32	33	34		
HARSH ENGAGEMENT FROM NEUTRAL TO D	X																																	X		
HARSH ENGAGEMENT FROM NEUTRAL TO R	X						X																											X		
DELAYED ENGAGEMENT FROM NEUTRAL TO D				X		X	X	X	X		X	X	X	X																						
DELAYED ENGAGEMENT FROM NEUTRAL TO R				X		X	X	X	X		X	X	X	X																						
RUNAWAY UPSHIFT																																				
NO UPSHIFT				X		X	X	X	X																										X	
3-2 KICKDOWN RUNAWAY				X		X	X	X	X																											
NO KICKDOWN OR NORMAL DOWNSHIFT						X																														
SHIFTS ERRATIC				X		X	X	X	X		X	X	X	X																					X	
SLIPS IN FORWARD DRIVE POSITIONS				X		X	X	X	X		X	X	X	X																					X	
SLIPS IN REVERSE ONLY				X		X	X	X	X		X	X	X	X																						
SLIPS IN ALL POSITIONS				X		X	X	X	X		X	X	X	X																						
NO DRIVE IN ANY POSITION				X		X	X	X	X		X	X	X	X																						
NO DRIVE IN FORWARD DRIVE POSITIONS				X		X	X	X	X		X	X	X	X																						
NO DRIVE IN REVERSE				X		X	X	X	X		X	X	X	X																						
DRIVES IN NEUTRAL						X																														
DRAGS OR LOCKS						X																														
GRATING, SCRAPING GROWLING NOISE				X																																
BUZZING NOISE						X																														
HARD TO FILL, OIL BLOWS OUT FILLER HOLE																																				
TRANSAXLE OVERHEATS				X		X	X	X	X		X	X	X	X																						
HARSH UPSHIFT				X																																X
DELAYED UPSHIFT																																				X
NO LOCKUP				X		X	X	X	X		X	X	X	X																						

DIAGNOSIS GUIDE—ABNORMAL NOISE

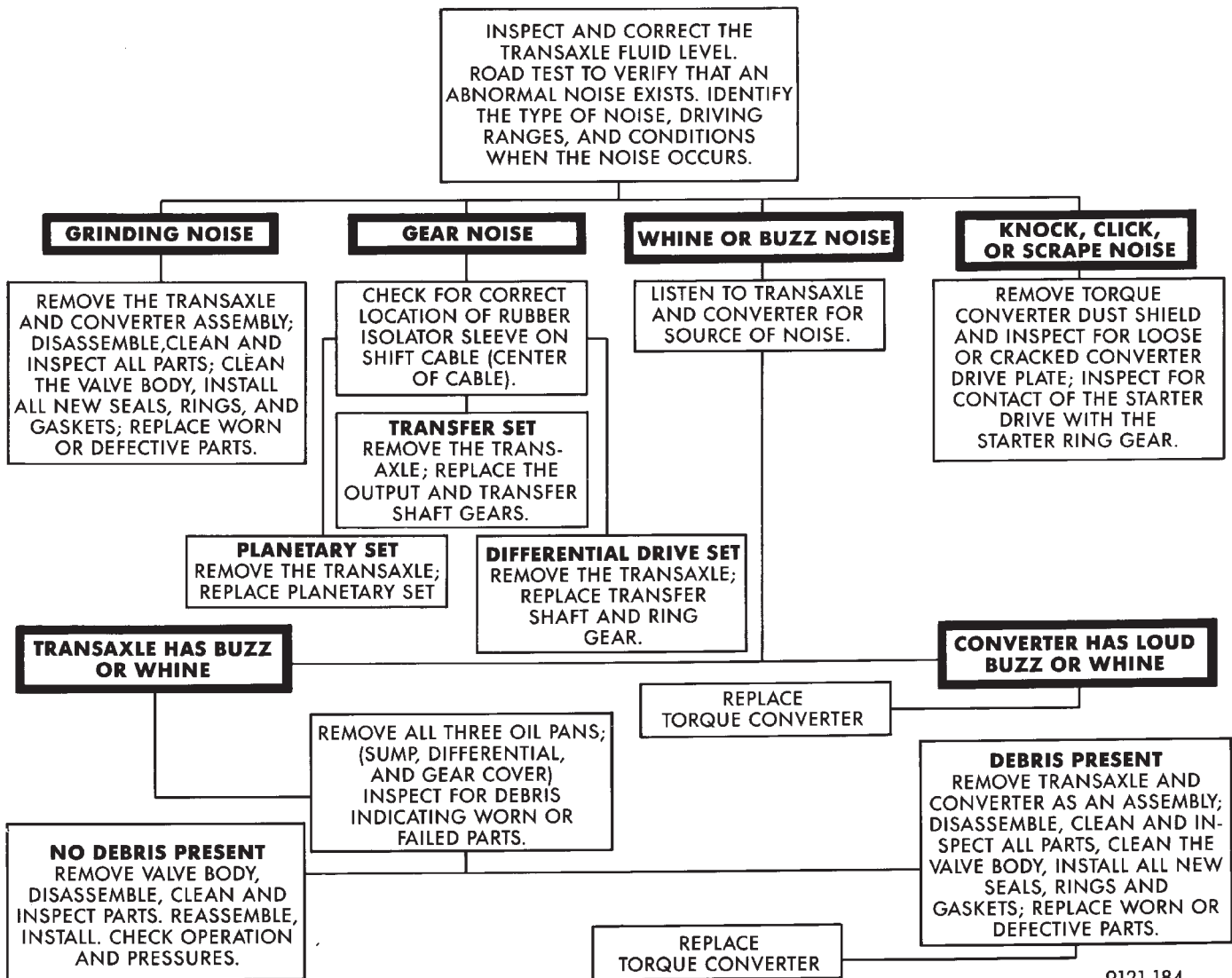

FLUID LEVEL AND CONDITION

The transmission and differential sump have a common oil sump with a communicating opening between the two.

Before removing the dipstick, wipe all dirt off of the protective disc and the dipstick handle.

The torque converter fills in both the "P" Park and "N" Neutral positions. Place the selector lever in "P" Park to be sure that the fluid level check is accurate. **The engine should be running at idle speed for at least one minute, with the vehicle on level ground. This will assure complete oil level stabilization between differential and transmission.** The fluid should be at normal operating temperature (approximately 82 C. or 180 F.). The fluid level is correct if it is in the "HOT" region (cross-hatched area) on the dipstick.

Low fluid level can cause a variety of conditions because it allows the pump to take in air along with the fluid. As in any hydraulic system, air bubbles make the fluid spongy, therefore, pressures will be low and build up slowly.

Improper filling can also raise the fluid level too high. When the transaxle has too much fluid, the gears churn up foam and cause the same conditions which occur with a low fluid level.

In either case, the air bubbles can cause overheating, fluid oxidation, and varnishing, which can interfere with normal valve, clutch, and servo operation. Foaming can also result in fluid escaping from the transaxle vent (dipstick handle) where it may be mistaken for a leak.

Along with fluid level, it is important to check the condition of the fluid. When the fluid smells burned, and is contaminated with metal or friction material particles, a complete transaxle overhaul is needed.

Be sure to examine the fluid on the dipstick closely. If there is any doubt about its condition, drain out a sample for a double check.

After the fluid has been checked, seat the dipstick fully to seal out water and dirt.

SELECTION OF LUBRICANT

It is important that the proper lubricant be used in these transmissions. MOPAR® ATF PLUS (Automatic Transmission Fluid-Type 7176) should be used to aid in assuring optimum transmission performance. Fluids of the type labeled DEXRON II Automatic Transmission Fluid should be used only if the recommended fluid is not available. If more than a small amount of Dexron fluid is used, shudder or shift quality problems may be encountered. It is important that the transmission fluid be maintained at the prescribed level using the recommended fluids.

SPECIAL ADDITIVES

Chrysler Corporation does not recommend the addition of any fluids to the transmission, other than the automatic transmission fluid listed above. An exception to this policy is the use of special dyes to aid in detecting fluid leaks. The use of transmission sealers should be avoided, since they may adversely affect seals.

FLUID AND FILTER CHANGE

When the factory fill fluid is changed, only fluids of the type labeled MOPAR® ATF PLUS (Automatic Transmission fluid) Type 7176 should be used. A band adjustment and filter change should be made at the time of the oil change. The magnet (inside of oil pan) should be cleaned with a clean, dry cloth.

If the transaxle is disassembled for any reason, the fluid and filter should be changed, and the band(s) adjusted.

FLUID DRAIN AND REFILL

(1) Raise vehicle on a hoist (See Lubrication, "Group 0"). Place a drain container with a large opening, under transaxle oil pan.

(2) Loosen pan bolts and tap the pan at one corner to break it loose allowing fluid to drain, then remove the oil pan.

(3) Install a new filter and gasket on bottom of the valve body and tighten retaining screws to 5 N•m (40 inch-pounds).

(4) Clean the oil pan and magnet. Reinstall pan using new sealant. Tighten oil pan bolts to 19 N•m (165 in. lbs.).

(5) Pour four quarts of MOPAR® ATF PLUS (Automatic Transmission Fluid) Type 7176 through the dipstick opening.

(6) Start engine and allow to idle for at least one minute. Then, with parking and service brakes ap-

plied, move selector lever momentarily to each position, ending in the park or neutral position.

(7) Add sufficient fluid to bring level to 1/8 inch below the ADD mark.

Recheck fluid level after transaxle is at normal operating temperature. The level should be in the HOT region (Fig. 1).

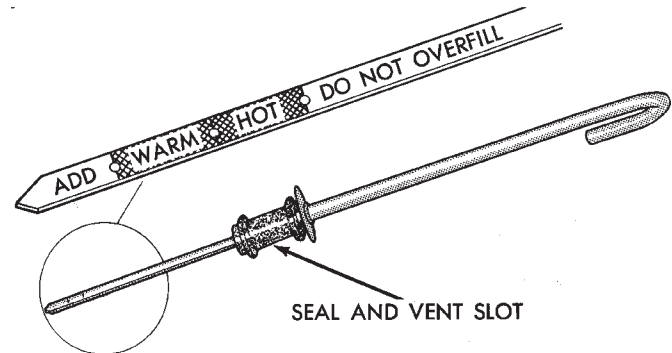

PR2082D

Fig. 1 Dipstick and Transaxle Vent

To prevent dirt from entering transaxle, make certain that dipstick is full seated into the dipstick opening.

LOCKUP SOLENOID WIRING CONNECTOR

If wiring connector is unplugged, the torque converter will not lock-up (Fig. 2).

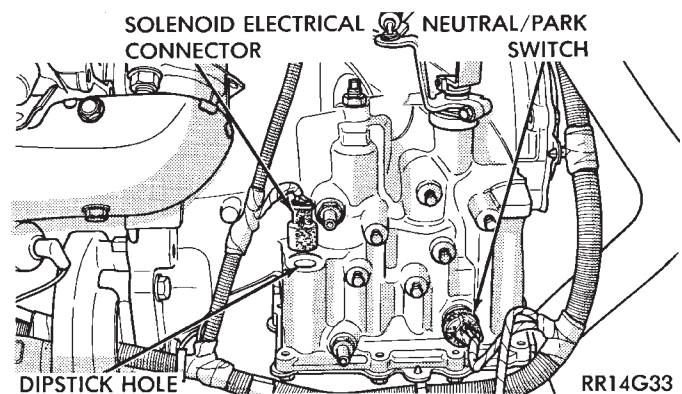

RR14G33

Fig. 2 Lockup Solenoid Wiring Connector

ROAD TEST

Prior to performing a road test, be certain that the fluid level and condition, and control cable adjustments have been checked and approved.

During the road test, the transaxle should be operated in each position to check for slipping and any variation in shifting.

If vehicle operates properly at highway speeds, but has poor through-gear acceleration, the torque converter stator overrunning clutch may be slipping. If through-gear acceleration is normal, but abnormally high throttle opening is required to maintain highway speeds, the torque converter stator clutch may



have seized. Both of these stator defects require replacement of the torque converter.

Observe closely for slipping or engine speed flare-up. Slipping or flare-up in any gear usually indicates clutch, band, or overrunning clutch problems. If the condition is far advanced, an overhaul will probably be necessary to restore normal operation.

In most cases, the clutch or band that is slipping can be determined by noting the transaxle operation in all selector positions. Then comparing which internal units are applied in those positions. The "Elements in Use Chart" provides a basis for road test analysis.

The rear clutch is applied in both the "D" first gear and "1" first gear positions. Also the overrunning clutch is applied in "D" first gear and the low/reverse band is applied in "1" first gear position. If the transaxle slips in "D" range first gear, but does not slip in "1" first gear, the overrunning clutch is slipping. Similarly, if the transaxle slips in any two forward gears, the rear clutch is slipping.

Using the same procedure, the rear clutch and front clutch are applied in "D" third gear. If the transaxle slips in third gear, either the front clutch or the rear clutch is slipping. By selecting another gear which does not use one of those units, the unit which is slipping can be determined. If the transaxle also slips in reverse, the front clutch is slipping. If the transaxle does not slip in reverse, the rear clutch is slipping.

The process of eliminating can be used to detect any unit which slips and to confirm proper operation of good units. However, although road test analysis can usually diagnose slipping units, the actual cause of the malfunction usually cannot be decided. Practically any condition can be caused by leaking hydraulic circuits or sticking valves.

Therefore, unless the condition is obvious, like no drive in "D" range first gear only, the transaxle should never be disassembled until hydraulic pressure tests have been performed.

HYDRAULIC PRESSURE TESTS

Pressure testing is a very important step in the diagnostic procedure. These tests usually reveal the cause of most transaxle problems.

Before performing pressure tests, be certain that fluid level and condition, and control cable adjustments have been checked and approved. Fluid must be at operating temperature (150 to 200 degrees F.).

Install an engine tachometer, raise vehicle on hoist which allows front wheels to turn, and position tachometer so it can be read.

Disconnect throttle cable and shift cable from transaxle levers so they can be controlled from outside the vehicle.

Attach 150 psi gauges to ports required for test being conducted. A 300 psi gauge (C-3293) is required for "reverse" pressure test at rear servo.

Test port locations are shown in (Fig. 3).

TEST ONE (SELECTOR IN "1")

- (1) Attach gauges to "line" and "low-reverse" ports (Fig. 3).
- (2) Operate engine at 1000 rpm for test.
- (3) Move selector lever on transaxle all the way rearward ("1" position).
- (4) Read pressures on both gauges as throttle lever on transaxle is moved from full clockwise position to full counterclockwise position.
- (5) Line pressure should read 52 to 58 psi with throttle lever clockwise and gradually increase, as lever is moved counterclockwise, to 80 to 88 psi.
- (6) Low-reverse pressure should read the same as line pressure within 3 psi.
- (7) This tests pump output, pressure regulation, and condition of rear clutch and rear servo hydraulic circuits.

ELEMENTS IN USE AT EACH POSITION OF THE SELECTOR LEVER

Lever Position	Start Safety	Parking Sprag	Clutches				Bands (Kickdown) (Low-Rev.)	
			Front	Rear	Lockup	Over-running	Front	Rear
P — PARK	X	X						
R — REVERSE			X					X
N — NEUTRAL	X							
D — DRIVE:								
First				X		X		
Second				X			X	
Third			X	X	X			
2 — SECOND:								
First				X		X		
Second				X			X	
1 — LOW (First)				X				X

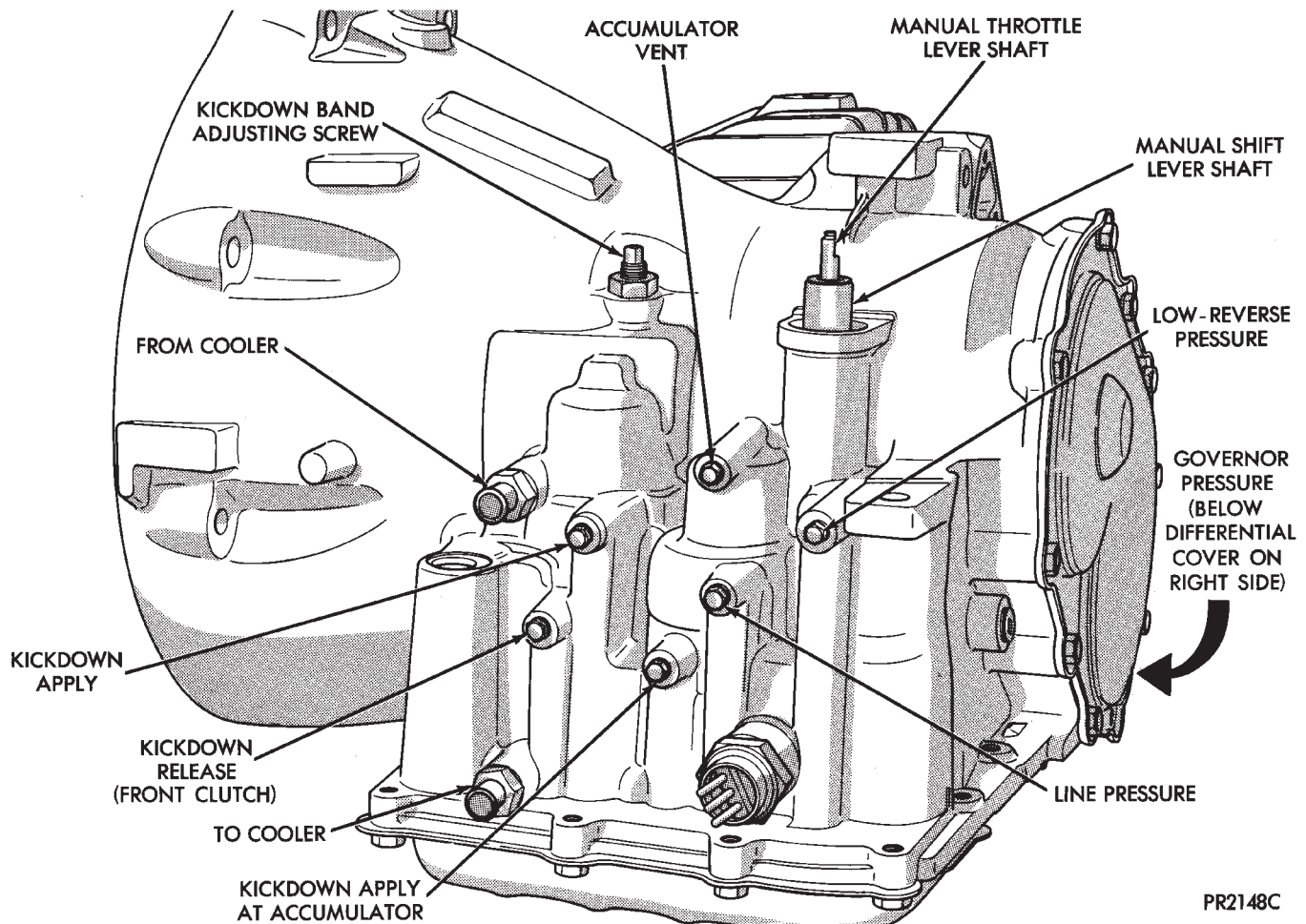

Fig. 3 Transaxle (Left Side)

TEST TWO (SELECTOR IN "2")

(1) Attach one gauge to "line pressure" port and "tee" another gauge into lower cooler line fitting to read "lubrication" pressure (Fig 3).

(2) Operate engine at 1000 rpm for test.

(3) Move selector lever on transaxle one "detent" forward from full rearward position. This is selector "2" position.

(4) Read pressures on both gauges as throttle lever on transaxle is moved from full clockwise position to full counterclockwise position.

(5) Line pressure should read 52 to 58 psi with throttle lever clockwise and gradually increase, as lever is moved counterclockwise, to 80 to 88 psi.

(6) Lubrication pressure should be 10 to 25 psi with lever clockwise and 10 to 35 psi with lever full counterclockwise.

(7) This tests pump output, pressure regulation, and condition of rear clutch and lubrication hydraulic circuits.

TEST THREE (SELECTOR IN "D")

(1) Attach gauges to "line" and "kickdown release" ports (Fig. 3).

(2) Operate engine at 1600 rpm for test.

(3) Move selector lever on transaxle two "detents" forward from full rearward position. This is selector "D" position.

(4) Read pressures on both gauges as throttle lever on transaxle is moved from full clockwise position to full counterclockwise position.

(5) Line pressure should read 52 to 58 psi with throttle lever clockwise and gradually increase, as lever is moved counterclockwise to 80 to 88 psi.

(6) Kickdown release is pressurized only in direct drive and should be same as line pressure within 3 psi, up to kickdown point.

(7) This tests pump output, pressure regulation, and condition of rear clutch, front clutch, and hydraulic circuits.

TEST FOUR (SELECTOR IN REVERSE)

(1) Attach 300 psi gauge to "low-reverse" port (Fig. 3).

(2) Operate engine at 1600 rpm for test.

(3) Move selector lever on transaxle four "detents" forward from full rearward position. This is selector "R" position.

(4) Low-reverse pressure should read 180 to 220 psi with throttle lever clockwise and gradually increase, as lever is moved counterclockwise to 260 to 300 psi.

(5) This tests pump output, pressure regulation, and condition of front clutch and rear servo hydraulic circuits.

(6) Move selector lever on transaxle to "D" position to check that low-reverse pressure drops to zero.

(7) This tests for leakage into rear servo, due to case porosity, which can cause reverse band burn out.

TEST RESULT INDICATIONS

(1) If proper line pressure, minimum to maximum, is found in any one test, the pump and pressure regulator are working properly.

(2) Low pressure in "D, 1, and 2" but correct pressure in "R" indicates rear clutch circuit leakage.

(3) Low pressure in "D and R" but correct pressure in "1" indicates front clutch circuit leakage.

(4) Low pressure in "R and 1" but correct pressure in "2" indicates rear servo circuit leakage.

(5) Low line pressure in all positions indicates a defective pump, a clogged filter, or a stuck pressure regulator valve.

GOVERNOR PRESSURE

Test only if transaxle shifts at wrong vehicle speeds when throttle cable is correctly adjusted.

(1) Connect a 0-150 psi pressure gauge to governor pressure take-off point, located at lower right side of case, below differential cover (Fig. 3).

(2) Operate transaxle in third gear to read pressures. The governor pressure should respond smoothly to changes in mph and should return to 0 to 3 psi when vehicle is stopped. High pressure at standstill (above 3 psi) will prevent the transaxle from downshifting.

THROTTLE PRESSURE

No gauge port is provided for throttle pressure. Incorrect throttle pressure should only be suspected if part throttle upshift speeds are either delayed or occur too early in relation to vehicle speeds, with correctly adjusted throttle cable. Engine runaway on either upshifts or downshifts can also be an indicator of incorrect (low) throttle pressure setting, or misadjusted throttle cable.

In no case should throttle pressure be adjusted until the transaxle throttle cable adjustment has been verified to be correct.

CLUTCH AND SERVO AIR PRESSURE TESTS

A "no drive" condition might exist even with correct fluid pressure, because of inoperative clutches or bands. The inoperative units, clutches, bands, and servos can be located through a series of tests by substituting air pressure for fluid pressure (Fig. 4).

The front and rear clutches, kickdown servo, and low-reverse servo may be tested by applying air pres-

sure to their respective passages after the valve body assembly has been removed. To make air pressure tests, proceed as follows:

Compressed air supply must be free of all dirt or moisture. Use a pressure of 30 psi.

Remove oil pan and valve body See "Disassembly-Subassembly Removal".

FRONT CLUTCH

Apply air pressure to front clutch "apply" passage and listen for a dull "thud" which indicates that front clutch is operating. Hold air pressure on for a few seconds and inspect system for excessive oil leaks.

REAR CLUTCH

Apply air pressure to rear clutch "apply" passage and listen for a dull "thud" which indicates that rear clutch is operating. Also inspect for excessive oil leaks. If a dull "thud" cannot be heard in the clutches, place finger tips on clutch housing and again apply air pressure. Movement of piston can be felt as the clutch is applied.

KICKDOWN SERVO (FRONT)

Direct air pressure into KICKDOWN SERVO "ON" passage. Operation of servo is indicated by a tightening of front band. Spring tension on servo piston should release the band.

LOW AND REVERSE SERVO (REAR)

Direct air pressure into LOW-REVERSE SERVO "APPLY" passage. Operation of servo is indicated by a tightening of rear band. Spring tension on servo piston should release the band.

If clutches and servos operate properly, "no upshift" or "erratic shift" conditions indicate that malfunctions exist in the valve body.

FLUID LEAKAGE-TRANSAXLE TORQUE CONVERTER HOUSING AREA

(1) Check for Source of Leakage.

Since fluid leakage at or around the torque converter area may originate from an engine oil leak, the area should be examined closely. Factory fill fluid is dyed red and, therefore, can be distinguished from engine oil.

(2) Prior to removing the transaxle, perform the following checks:

When leakage is determined to originate from the transaxle, check fluid level prior to removal of the transaxle and torque converter.

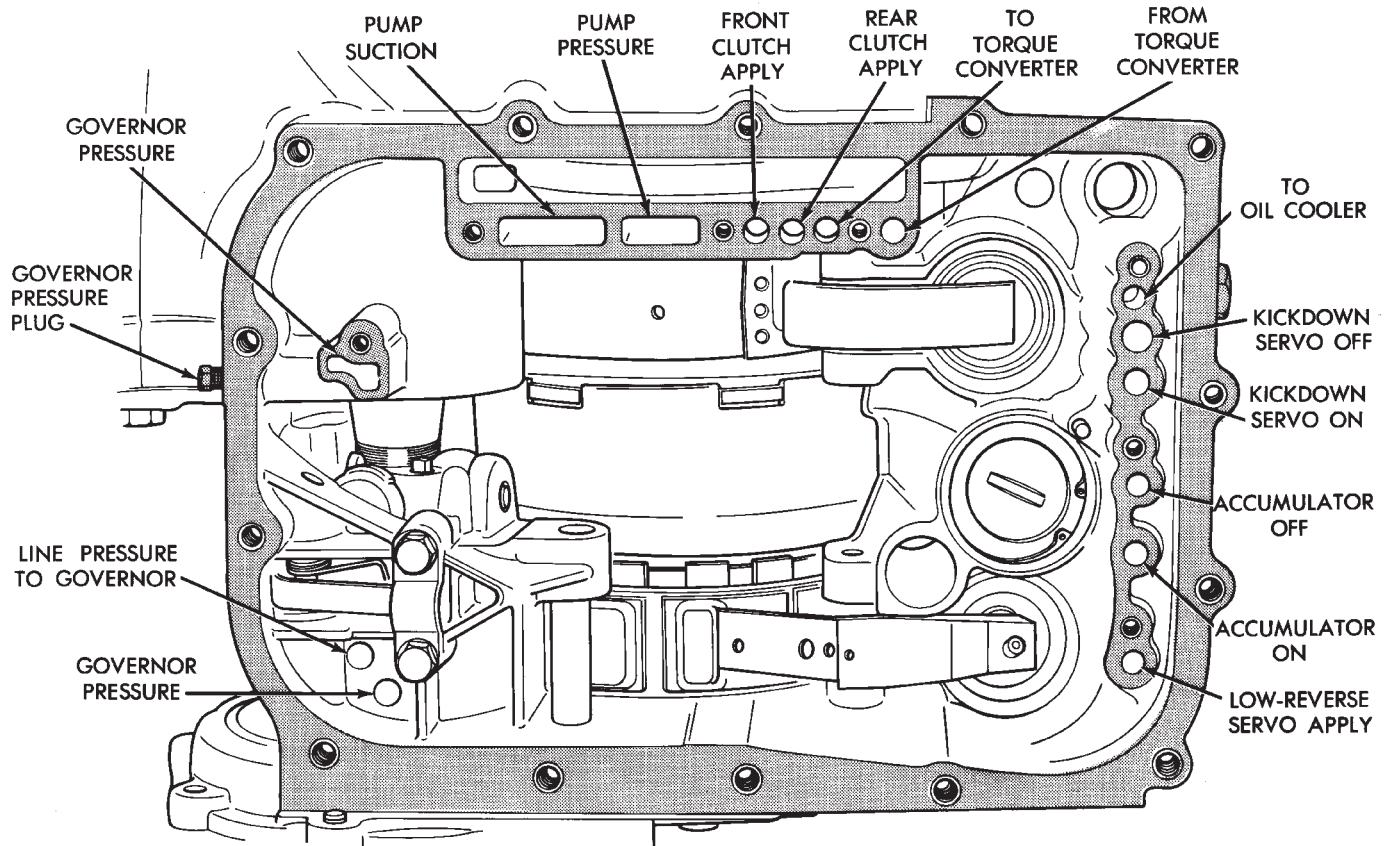

PU142A

Fig. 4 Air Pressure Tests

High oil level can result in oil leakage out the vent in the dipstick. If the fluid level is high, adjust to proper level.

After performing this operation, inspect for leakage. If a leak persists, perform the following operation on the vehicle to determine if it is the torque converter or transaxle that is leaking.

LEAKAGE TEST PROBE

- (1) Remove torque converter housing dust shield.
- (2) Clean the inside of torque converter housing (lower area) as dry as possible. A solvent spray followed by compressed air drying is preferable.
- (3) Fabricate and fasten test probe (Fig. 5) securely to convenient dust shield bolt hole. Make certain torque converter is cleared by test probe. Tool must be clean and dry.
- (4) Run engine at approximately 2,500 rpm with transaxle in neutral, for about 2 minutes. Transaxle must be at operating temperature.
- (5) Stop engine and carefully remove tool.
- (6) If upper surface of test probe is dry, there is no torque converter leak. A path of fluid across probe indicates a torque converter leak. Oil leaking under the probe is coming from the transaxle pump area.
- (7) Remove transaxle and torque converter assembly from vehicle for further investigation. The fluid should

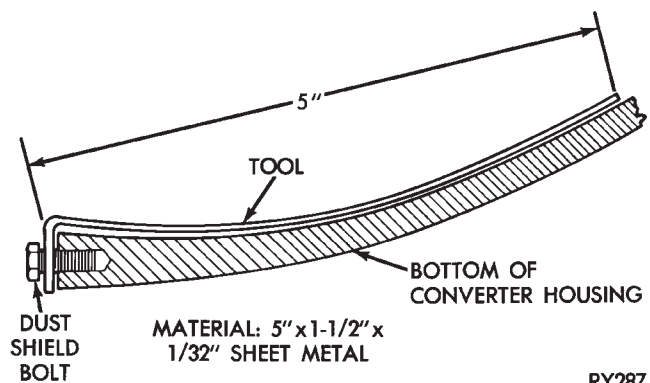

RY287

Fig. 5 Leak Locating Test Probe Tool

be drained from the transaxle. Reinstall oil pan (with Mopar® Silicone Rubber Adhesive Sealant or equivalent) at specified torque.

Possible sources of transaxle torque converter area fluid leakage are:

- (1) Torque converter hub seal.
 - Seal lip cut, check torque converter hub finish.
 - Bushing moved and/or worn.
 - Oil return hole in pump housing plugged or omitted.
 - Seal worn out (high-mileage vehicles).



(2) Fluid leakage at the outside diameter from pump housing O-ring.

(3) Fluid leakage at the pump to case bolts. Check condition of washers on bolts and use new bolts if necessary.

(4) Fluid leakage due to case or pump housing porosity.

TORQUE CONVERTER LEAKAGE

Possible sources of torque converter leakage are:

- Torque converter weld leaks at the outside diameter (peripheral) weld.
- Torque converter hub weld.
- Torque converter impeller shell cracked adjacent to hub.
- At drive lug welds.

Hub weld is inside and not visible. Do not attempt to repair. Replace torque converter.

AIR PRESSURE TEST OF TRANSAXLE

Fabricate equipment needed for test as shown in figures 6 and 7.

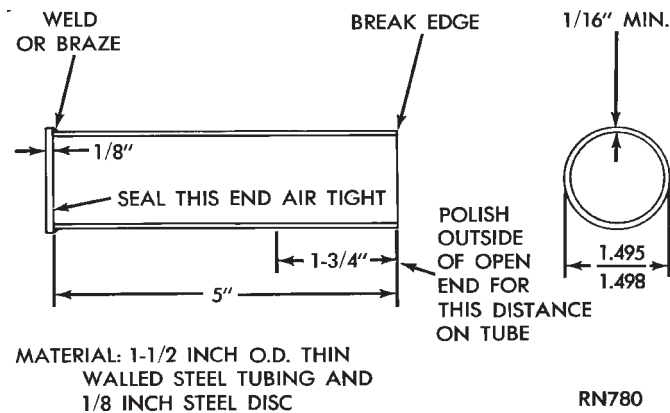

Fig. 6 Torque Converter Hub Seal Cup

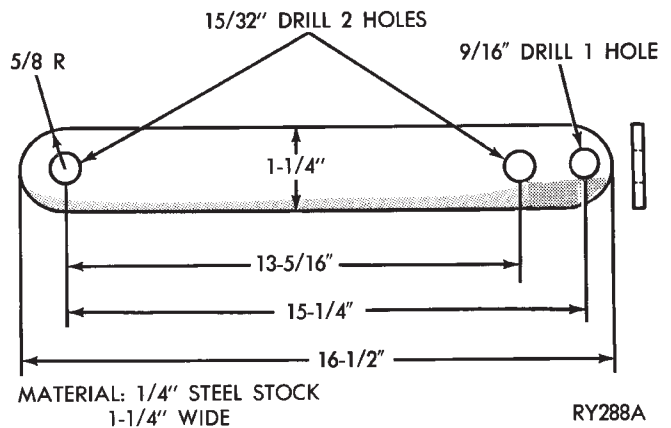

Fig. 7 Hub Seal Cup Retaining Strap

The transaxle should be prepared for pressure test as follows after removal of the torque converter:

(1) Install a dipstick bore plug and plug oil cooler line fitting (lower fitting).

(2) With rotary motion, install converter hub seal cup over input shaft, and through the converter hub seal until the cup bottoms against the pump gear lugs. Before use, inspect hub seal cup (Fig. 6) for nicks or burrs that could damage seal. Secure with cup retainer strap (Fig. 7) using starter upper hole and opposite bracket hole.

(3) Attach and clamp hose from nozzle of Tool C-4080 to the upper cooler line fitting position in case.

CAUTION: Do not, under any circumstances, pressurize a transaxle to more than 10 psi.

(4) Pressurize the transaxle using Tool C-4080 until the pressure gauge reads 8 psi. Position transaxle so that pump housing and case front may be covered with soapy solution or water. Leaks are sometimes caused by porosity in the case or pump housing.

If a leak source is located, that part and all associated seals, O-rings, and gaskets should be replaced with new parts.

GEARSHIFT LINKAGE ADJUSTMENT

Normal operation of the neutral safety switch provides a quick check to confirm proper manual linkage adjustment.

Move the selector level slowly upward until it clicks into the "P" Park notch in the selector gate. If the starter will operate, the "P" position is correct.

After checking "P" position, move the selector slowly toward "N" Neutral position until lever drops at the end of the "N" stop. If the starter will also operate at this point the gearshift linkage is properly adjusted. If the starter fails to operate in either position, linkage adjustment is required.

CAUTION: When it is necessary to disassemble linkage cable from levers, which use plastic grommets as retainers, the grommets should be replaced with new grommets. Use a prying tool to force rod from grommet in lever, then cut away old grommet. Use pliers to snap new grommet into lever and rod into grommet.

- (1) Set parking brake.
- (2) Place gearshift lever in "P" (PARK) position.
- (3) Loosen clamp bolt on gearshift cable bracket.
- (4) Column shift: Insure that preload adjustment spring engages fork on transaxle bracket.
- (5) Pull the shift lever by hand all the way to the front detent position (PARK) and tighten lock. Tighten screw to 11 N•m (100 in. lbs.). Gearshift linkage should now be properly adjusted.

(6) Check adjustment as follows:

(a) Detent position for neutral and drive should be within limits of hand lever gate stops.

(b) Key start must occur only when shift lever is in park or neutral positions.

(7) If console removal is required, disconnect battery ground cable. To remove button assembly, insert a 1/16 inch diameter wire in hole in bottom of knob and push up on wire. To remove knob retainer clip, insert long-nose plier tips in clip holes, push downward lightly and turn counterclockwise (action similar to a light bulb socket). Pull knob straight up to remove from gearshift lever. Proceed as outlined in console removal, "Group 23".

After console is back in place, install shift knob and button by reversing the above procedure.

(8) To remove button assembly, completely remove knob attaching fasteners. Pull knob "up" sharply. Proceed as outlined in console removal, "Group 23."

After console is back in place, install knob and button by reversing the above procedure.

THROTTLE PRESSURE LINKAGE ADJUSTMENT

The throttle pressure cable adjustment is very important to proper transaxle operation. This adjustment positions a valve which controls shift speed, shift quality, and part throttle downshift sensitivity. If the setting is too long, early shifts and slippage between

shifts may occur. If the setting is too short, shifts may be delayed and part throttle downshifts may be very sensitive.

With engine at operating temperature, adjust idle speed of engine using a tachometer. Refer to "Fuel System" Group 14 for idle speed Specifications and adjustment.

CABLE ADJUSTMENT PROCEDURE (4-CYL.)

(1) Perform transaxle throttle pressure cable adjustment while engine is at normal operating temperature.

(2) Loosen cable mounting bracket lock screw.

(3) Bracket should be positioned with both bracket alignment tabs touching the transaxle cast surface. Tighten lock screw to 12 N•m (105 in. lbs.) see Figure 8.

(4) Release cross-lock on the cable assembly (pull cross-lock upward) see Figure 8.

(5) To insure proper adjustment, the cable must be free to slide all the way toward the engine, against its

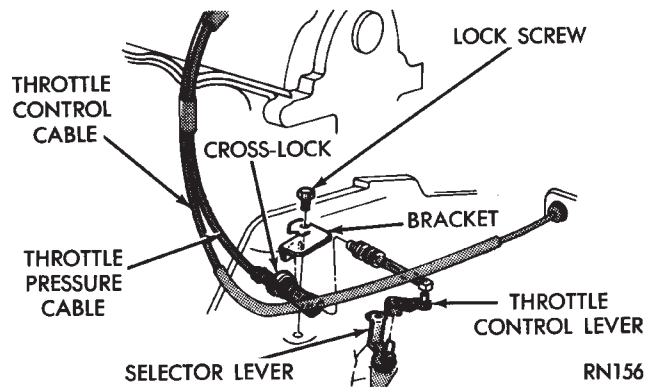

Fig. 8 Throttle Pressure Cable (Typical)

stop, after the cross-lock is released.

(6) Move transaxle throttle control lever fully clockwise, against its internal stop, and press cross-lock downward into locked position.

(7) The adjustment is complete and transaxle throttle cable backlash was automatically removed.

(8) Test cable freedom of operation by moving the transaxle throttle lever forward (counterclockwise) and slowly release it to confirm it will return fully rearward (clockwise).

(9) No lubrication is required for any component of the throttle cable system.

ROD ADJUSTMENT PROCEDURE (6-CYL.)

(1) Perform transaxle throttle pressure cable adjustment while engine is at normal operating temperature.

(2) Loosen adjustment swivel lock screw.

(3) To insure proper adjustment, swivel must be free to slide along flat end of throttle rod so that pre-

load spring action is not restricted. Disassemble and clean or repair parts to assure free action, if necessary.

(4) Hold transaxle throttle lever firmly toward engine, against its internal stop and tighten swivel lock screw to 11 N•m (100 in. lbs.)

(5) The adjustment is finished and linkage back lash was automatically removed by the preload spring.

(6) If lubrication is required see Lubrication, Group 0.

BAND ADJUSTMENT

KICKDOWN BAND (FRONT)

The kickdown band adjusting screw is located on left side (top front) of the transaxle case.

(1) Loosen locknut and back off nut approximately five turns. Test adjusting screw for free turning in the transaxle case.

(2) Using wrench, Tool C-3880-A with adapter Tool C-3705, tighten band adjusting screw to 5 N•m (47 to 50 in. lbs.). If adapter C-3705 is not used, tighten adjusting screw to 8 N•m (72 in. lbs.) which is the true torque.

(3) Back off adjusting screw the number of turns listed in "Specifications". Hold adjusting screw in this position and tighten locknut to 47 N•m (35ft. lbs.)

LOW/REVERSE BAND (REAR)

To adjust low-reverse band, proceed as follows:

(1) Loosen and back off locknut approximately 5 turns.

(2) Using an inch-pound torque wrench, tighten adjusting screw to 5 N•m (41 in. lbs.) true torque.

(3) Back off adjusting screw the number of turns listed under "Specifications" in the rear of the Transaxle Section in this service manual.

(4) Tighten locknut to 14 N•m (10 ft. lbs.).

HYDRAULIC CONTROL PRESSURE ADJUSTMENTS

LINE PRESSURE

An incorrect throttle pressure setting will cause incorrect line pressure readings even though line pressure adjustment is correct. Always inspect and correct throttle pressure adjustment before adjusting the line pressure.

The approximate adjustment for line pressure is 1-5/16 inches, measured from valve body to inner edge of adjusting nut. However, due to manufacturing tolerances, the adjustment can be varied to obtain specified line pressure.

The adjusting screw may be turned with an Allen wrench. One complete turn of adjusting screw changes closed throttle line pressure approximately 1-2/3 psi. Turning adjusting screw counterclockwise increases pressure, and clockwise decreases pressure.

THROTTLE PRESSURE

Throttle pressures cannot be tested accurately; therefore, the adjustment should be measured if a malfunction is evident.

(1) Insert gauge pin of Tool C-3763 between the throttle lever cam and kickdown valve.

(2) By pushing in on tool, compress kickdown valve against its spring so throttle valve is completely bottomed inside the valve body.

(3) While compressing spring, turn throttle lever stop screw with adapter C-4553. Turn until head of screw touches throttle lever tang, with throttle lever cam touching tool and throttle valve bottomed. Be sure adjustment is made with spring fully compressed and valve bottomed in the valve body.

DISTANCE SENSOR PINION GEAR

When the distance sensor is removed for any reason, a NEW O-ring must be installed on its outside diameter.

REMOVAL AND INSTALLATION

(1) Remove speedometer cable (if so equipped).

(2) Remove harness connector from sensor. Make sure weatherseal stays on harness connector.

(3) Remove bolt securing the distance sensor in the extension housing.

(4) Carefully pull sensor and pinion gear assembly out of extension housing.

(5) Remove pinion gear from sensor.

(6) To install, reverse the above procedure. Make sure extension housing and sensor flange are clean prior to installation. Always use a NEW sensor O-ring.

(7) Tighten securing bolt to 7 N•m (60 in. lbs.). Tighten speedometer cable to 4 N•m (35 in. lbs.).

NEUTRAL STARTING AND BACK-UP LAMP SWITCH

REPLACEMENT AND TEST

The neutral starting switch is the center terminal of the 3 terminal switch. It provides ground for the starter solenoid circuit through the selector lever in only Park and Neutral positions.

(1) To test switch, remove wiring connector from switch and test for continuity between center pin of switch and transaxle case. Continuity should exist only when transaxle is in Park or Neutral.

(2) Check gearshift cable adjustment before replacing a switch which tests bad.

(3) Unscrew switch from transaxle case allowing fluid to drain into a container. Move selector lever to Park and then to Neutral positions, and inspect to see that the switch operating lever fingers are centered in switch opening in the case.

(4) Screw the switch with a new seal into transaxle case and tighten to 33 N•m (24 ft. lbs.). Retest switch with the test lamp.

(5) Add fluid to transaxle to bring up to proper level.

(6) The back-up lamp switch circuit is through the two outside terminals of the 3 terminal switch.

(7) To test switch, remove wiring connector from switch and test for continuity between the two outside pins.

(8) Continuity should exist only with transaxle in Reverse position.

(9) No continuity should exist from either pin to the case.

GOVERNOR

To service the governor assembly in the vehicle, it is not necessary to remove the transfer gear cover, transfer gear, and governor support. The governor may be serviced by removing the transaxle oil pan and valve body assembly. With the oil pan and valve body removed, the governor may be unbolted from the governor support and removed from the transaxle for reconditioning or replacement.

When cleaning or assembling the governor, make sure the governor valves move freely in the bores of the governor body.

ALUMINUM THREAD REPAIR

Damaged or worn threads in the aluminum transaxle case and valve body can be repaired by the use of Heli-Coils, or equivalent. This repair consists of drilling out the worn-out damaged threads. Then tapping the hole with a Heli-Coil tap, or equivalent, and installing a Heli-Coil insert, or equivalent, into the hole. This brings the hole back to its original thread size.

Heli-Coil, or equivalent, tools and inserts are readily available from most automotive parts suppliers.

OIL COOLERS AND TUBES REVERSE FLUSHING

When a transaxle failure has contaminated the fluid, the oil cooler(s) must be flushed and the cooler bypass valve in the transaxle must be replaced. The torque converter must also be replaced with an exchange unit. This will insure that metal particles or sludged oil are not transferred back into the reconditioned (or replaced) transaxle.

CAUTION: If vehicle is equipped with two oil coolers (one in the radiator tank, one in front of the radiator) they must be flushed separately. Do not attempt to flush both coolers at one time.

(1) Disconnect the cooler lines at the transmission.

(2) Using a hand suction gun filled with mineral spirits, reverse flush the cooler by forcing mineral spirits into the **From Cooler** line of the cooler (Fig. 1). Catch the exiting spirits from the **To Cooler** line.

Observe for the presence of debris in the exiting fluid. Continue until fluid exiting is clear and free from debris.

(3) Using compressed air in intermittent spurts, blow any remaining mineral spirits from the cooler,

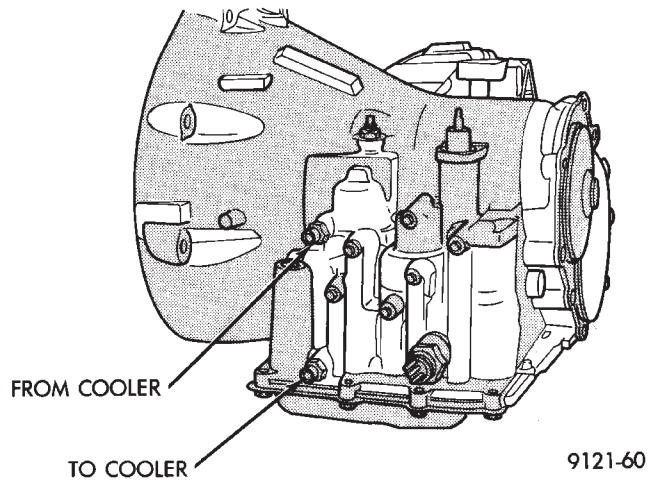

Fig. 1 Cooler Line Identification

again in the reverse direction.

(4) To remove any remaining mineral spirits from the cooler, one (1) quart of automatic transmission fluid should be pumped through the cooler before reconnecting.

(5) If at any stage of the cleaning process, the cooler does not freely pass fluid, the cooler must be replaced.

OIL COOLER FLOW CHECK

After the new or repaired transmission has been installed and filled to the proper level with automatic transmission fluid, the flow should be checked using the following procedure:

(1) Disconnect the **From cooler** line at the transmission and place a collecting container under the disconnected line.

(2) Run the engine **at curb idle speed**, with the shift selector in neutral.

(3) If the fluid flow is intermittent or it takes more than 20 seconds to collect one quart of automatic transmission fluid, the cooler should be replaced.

CAUTION: With the fluid set at the proper level, fluid collection should not exceed (1) quart or internal damage to the transmission may occur.

(4) If flow is found to be within acceptable limits, reconnect the cooler line and fill transmission to the proper level, using the approved type of automatic transmission fluid.

TRANSAXLE AND TORQUE CONVERTER REMOVAL

Transaxle removal does **NOT** require engine removal.

(1) The transaxle and torque converter must be removed as an assembly; otherwise, the torque converter drive plate, pump bushing, or oil seal may be damaged. The drive plate will not support a load; therefore, none of the weight of the transaxle should be allowed to rest on the plate during removal.

(2) Disconnect or connect **negative** battery cable.

(3) Disconnect or connect throttle linkage and shift linkage from transaxle.

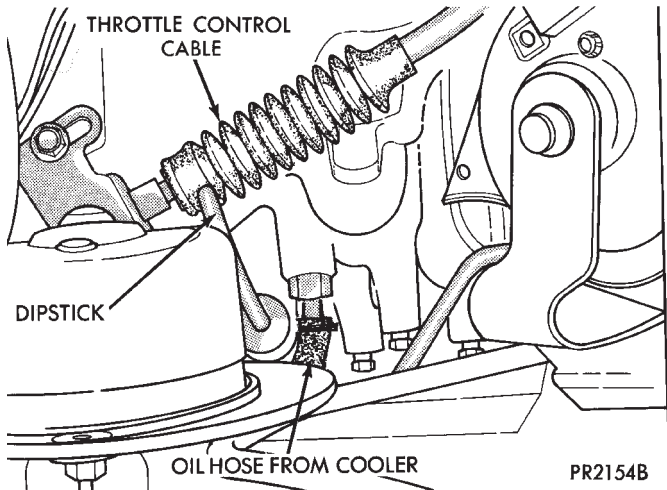

Fig. 1 Remove Upper and Lower Oil Cooler Hoses
If so equipped, unplug lockup torque converter

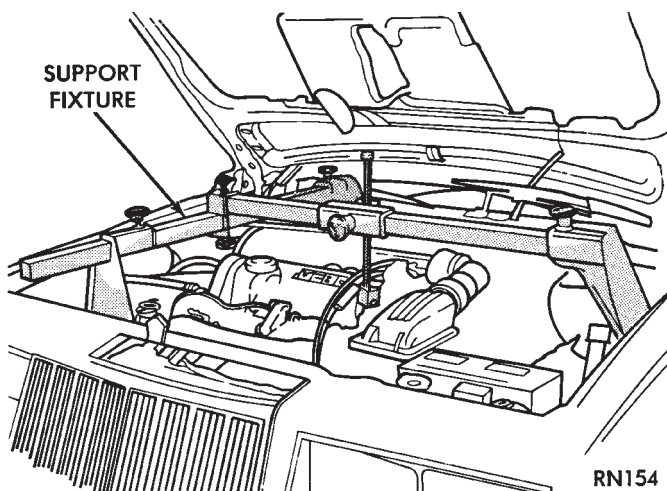

Fig. 2 Engine Support Fixture (Typical)
plug, located near the dipstick.

CAUTION: Raise vehicle. Remove front wheels. Refer to "Suspension, Group 2" to remove or install wheel hub nut and both drive shafts.

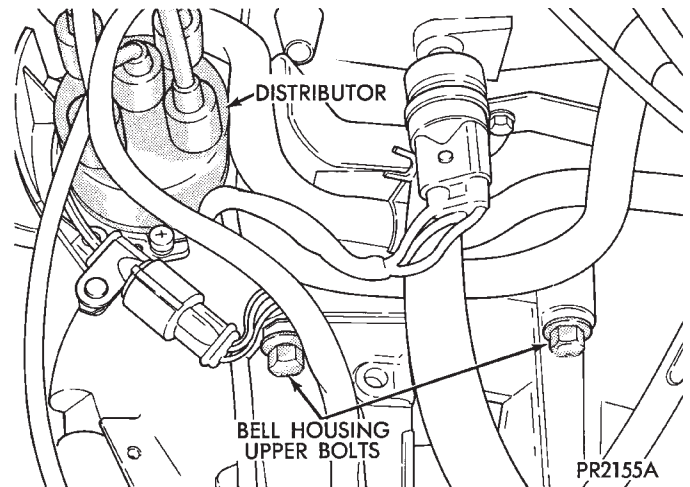

Fig. 3 Remove Bell Housing Upper Bolts

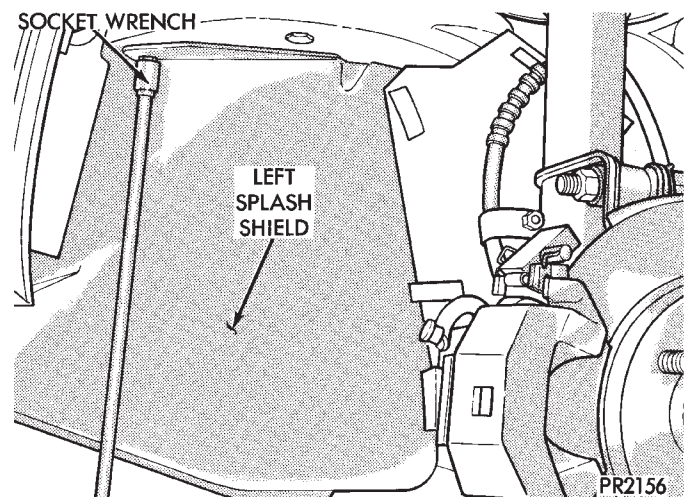

Fig. 4 Remove or Install Left Splash Shield

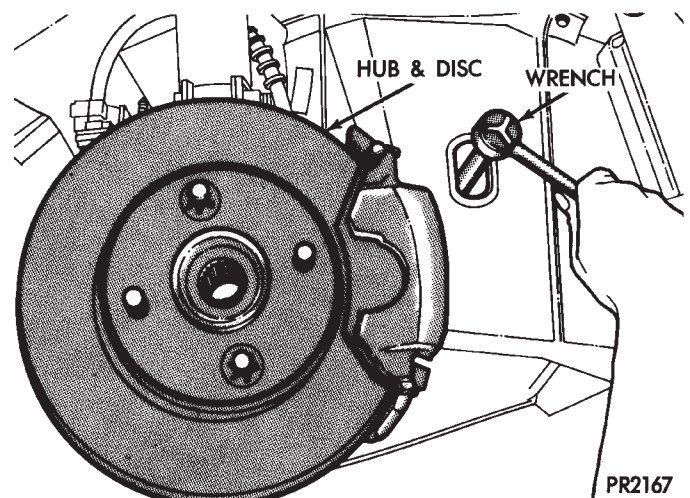

Fig. 5 Remove or Install Access Plug in Right Splash Shield to Rotate Engine Crankshaft

Remove torque converter dust cover. Mark torque converter and drive plate with chalk, for reassembly. Remove torque converter mounting bolts.

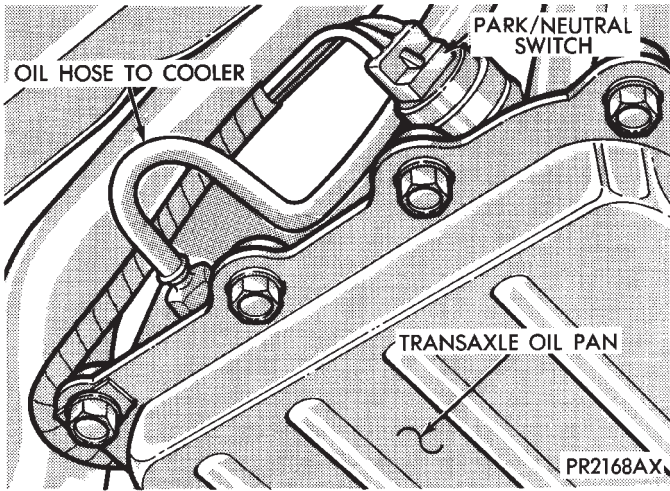

Fig. 6 Remove or Install Wire to Neutral/Park Safety Switch

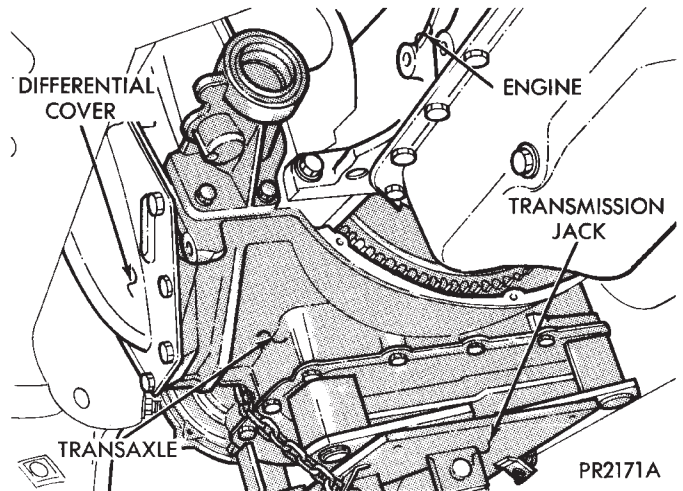

Fig. 9 Positioning Transmission Jack

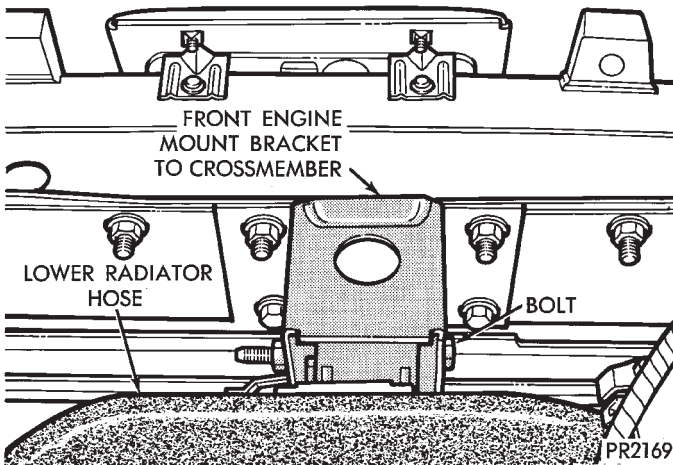

Fig. 7 Remove or Install Engine Mount Bracket from Front Crossmember

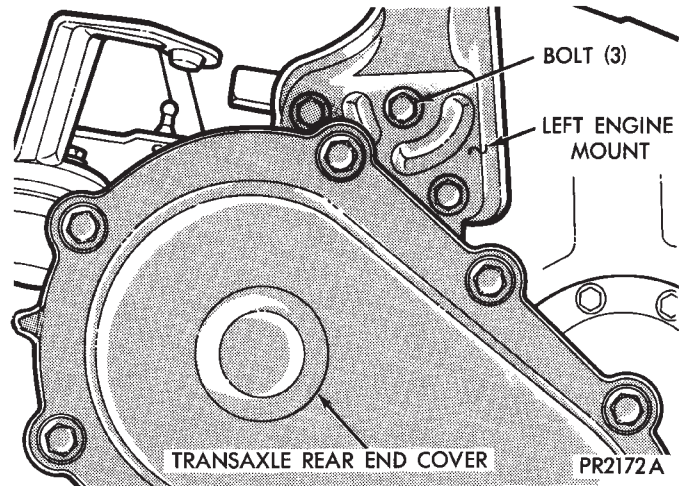

Fig. 10 Remove or Install Left Engine Mount

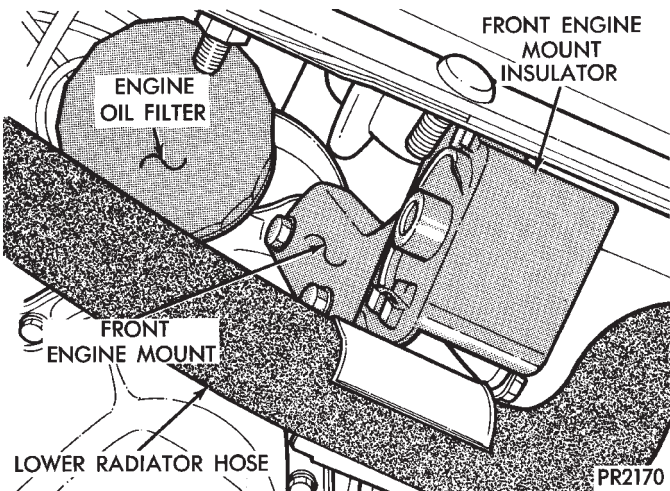

Fig. 8 Remove or Install Front Mount Insulator Through-Bolt and Bell Housing Bolts

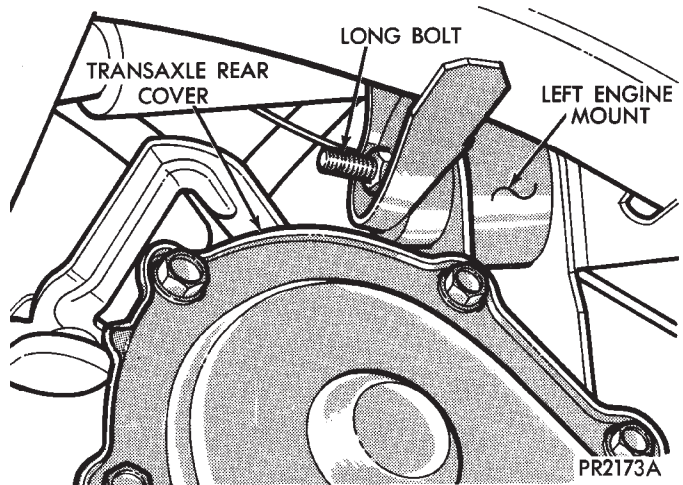

Fig. 11 Remove or Install Left Engine Mount from Engine

Remove or install starter. Remove or install lower bell housing bolts.

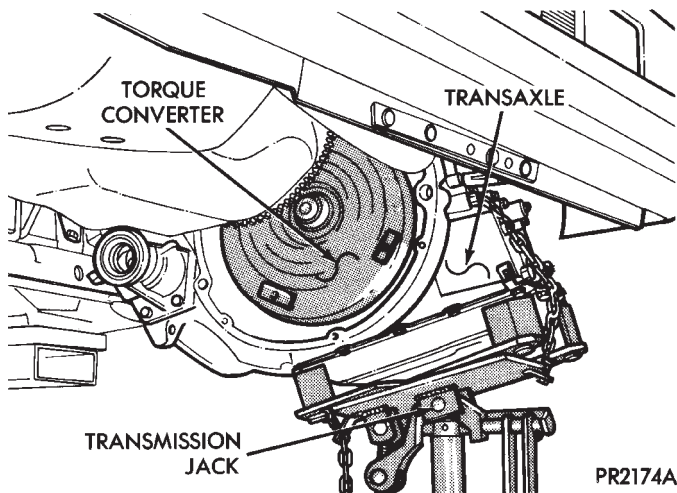

Fig. 12 Raise or Lower Transaxle

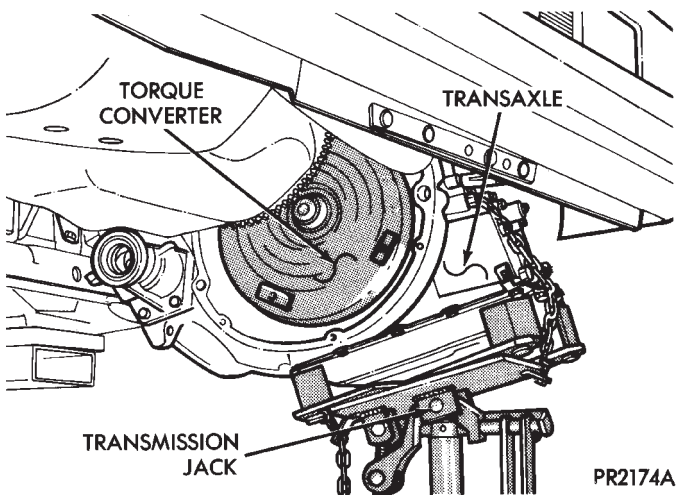

Fig. 13 Pry Engine for Clearance

Carefully work transaxle and torque converter assembly rearward off engine block dowels and disengage converter hub from end of crankshaft. **Attach a small "C" clamp to edge of bell housing. This will hold torque converter in place during transaxle removal.** Lower transaxle and remove assembly from under the vehicle.

When installing transaxle, reverse the above procedure.

To remove torque converter assembly, remove "C" clamp from edge of bell housing and slide converter out of transaxle.

If torque converter was removed from transaxle be sure to align pump inner gear pilot flats with torque converter impeller hub flats.

Adjust gearshift and throttle cables.

Refill transaxle with MOPAR® ATF PLUS (Automatic Transmission Fluid) Type 7176.

TRANSAXLE DISASSEMBLY (SUBASSEMBLY REMOVAL)

Prior to removing any transaxle subassemblies, plug all openings and thoroughly clean exterior of the unit, preferably by steam. Cleanliness through entire disas-

sembly and assembly cannot be overemphasized. When disassembling, each part should be washed in a suitable solvent, then dried by compressed air. Do not wipe

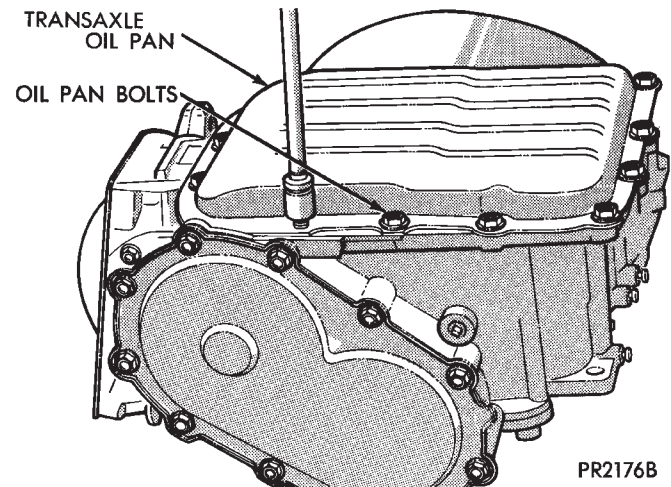

Fig. 1 Transaxle Oil Pan Bolts

parts with shop towels. All mating surfaces in the transaxles are accurately machined; therefore, careful handling of all parts must be exercised to avoid nicks or burrs.

Remove all old sealant before applying new sealant. Use only Mopar® Silicone Rubber Sealant or equivalent.

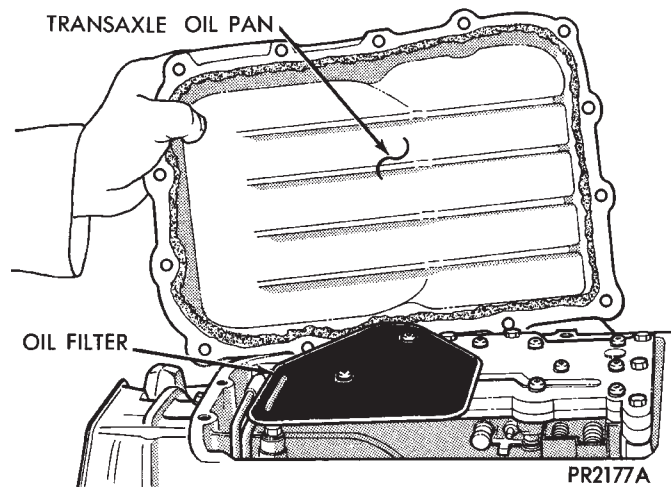

Fig. 2 Transaxle Oil Pan

lent when installing oil pan.

Put sealant on the oil pan flange (Fig. 2) and on all oil pan bolts (underside of bolt head).

Remove or install neutral starting and back-up lamp switch.

Measuring input shaft end play before disassembly will usually indicate when a thrust washer change is required, (except when major parts are replaced). The thrust washer is located between input and output shafts.

Attach a dial indicator to transaxle bell housing with its plunger seated against end of input shaft (Fig. 9).

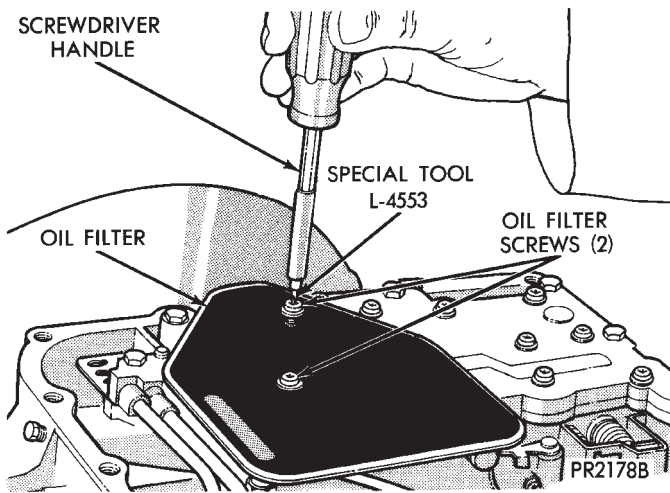

Fig. 3 Oil Filter Screws

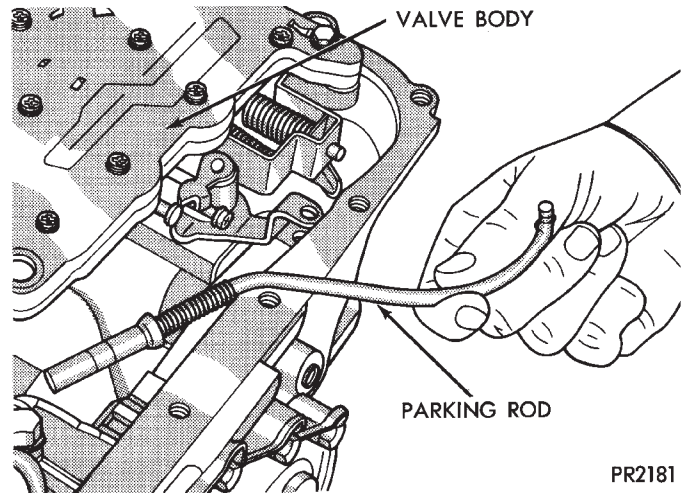

Fig. 6 Parking Rod

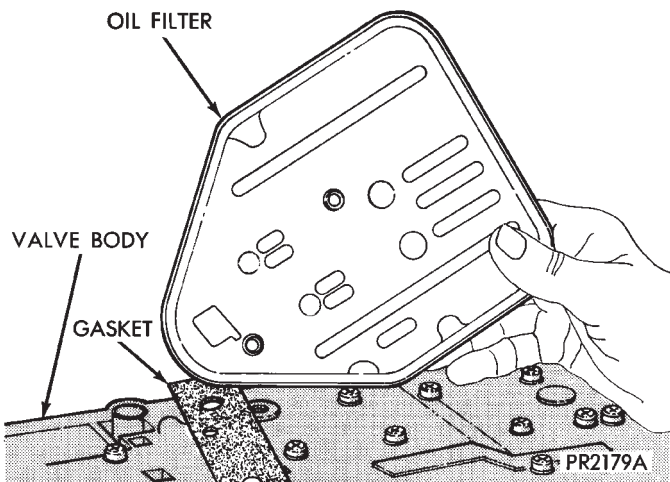

Fig. 4 Oil Filter

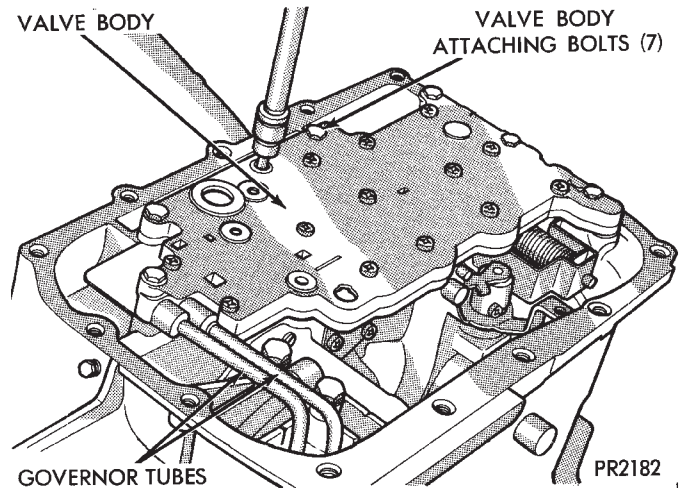

Fig. 7 Valve Body Attaching Bolts

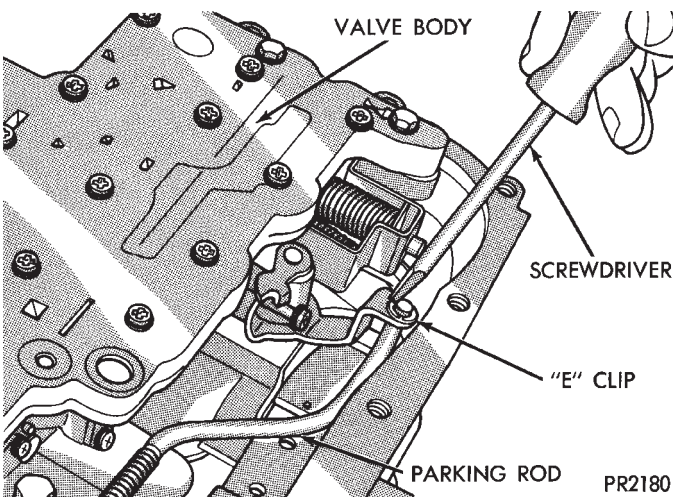

Fig. 5 Remove or Install Parking Rod E-Clip

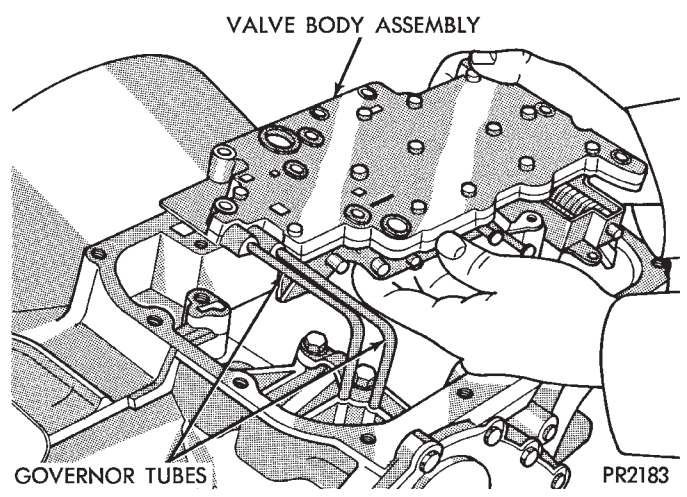

Fig. 8 Valve Body and Governor Tubes

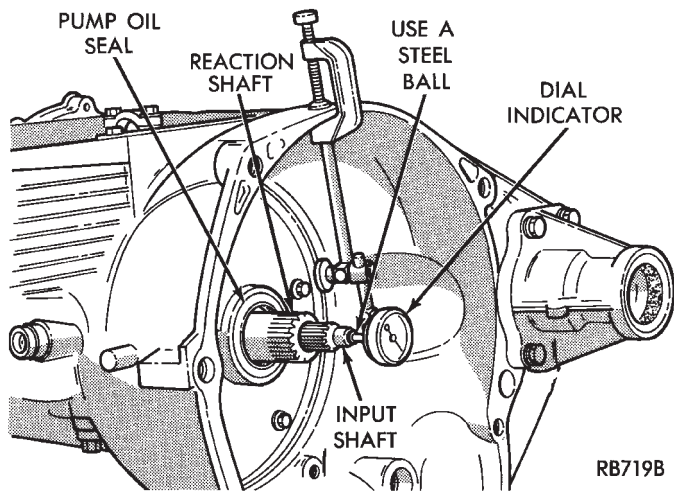

Fig. 9 Measure Input Shaft End Play

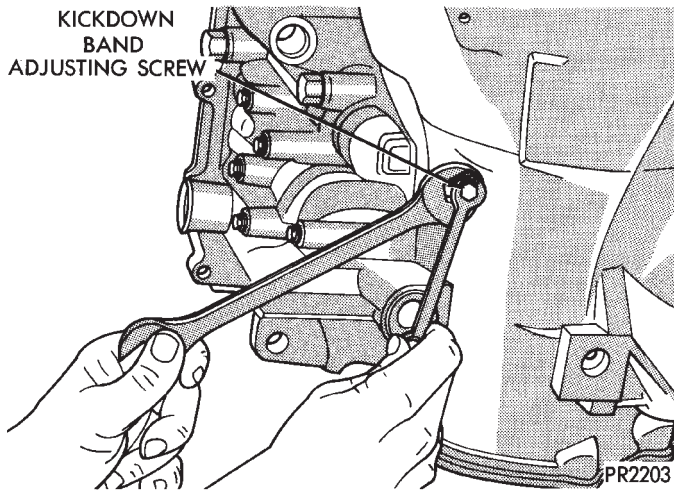

Fig. 10 Loosen Lock Nut and Tighten Kickdown Band Adjusting Screw

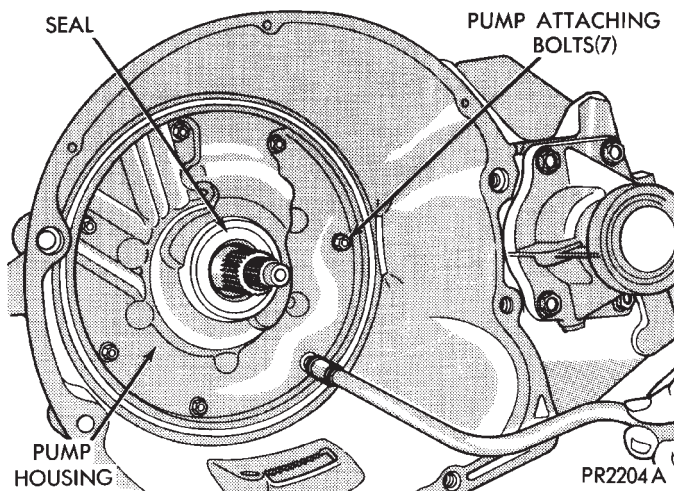

Fig. 11 Pump Attaching Bolts

Move input shaft in and out to obtain end play reading. End play specifications are 0.19 to 1.50 mm (.008 to .060 inch).

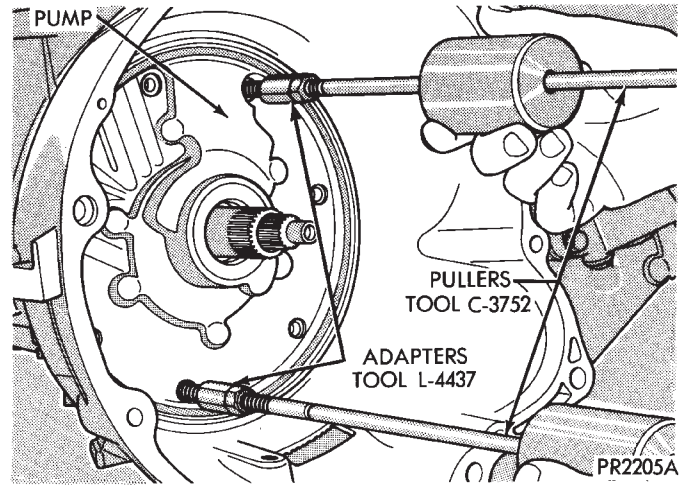

Fig. 12 Install Tool C-3752 with Adapters L-4437

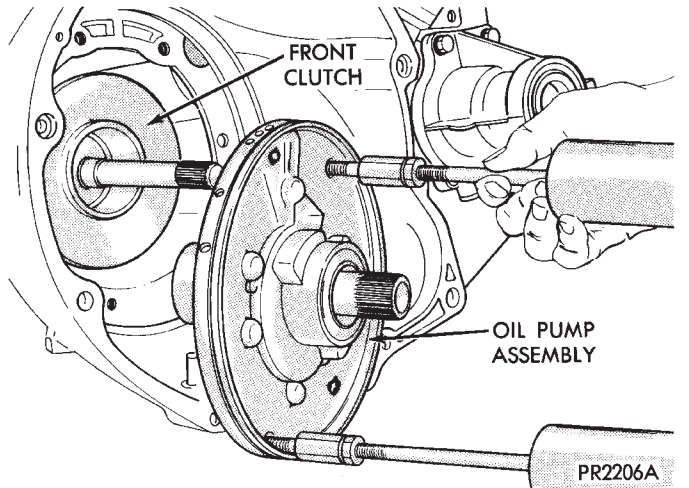

Fig. 13 Oil Pump with No. 1 Thrust Washer

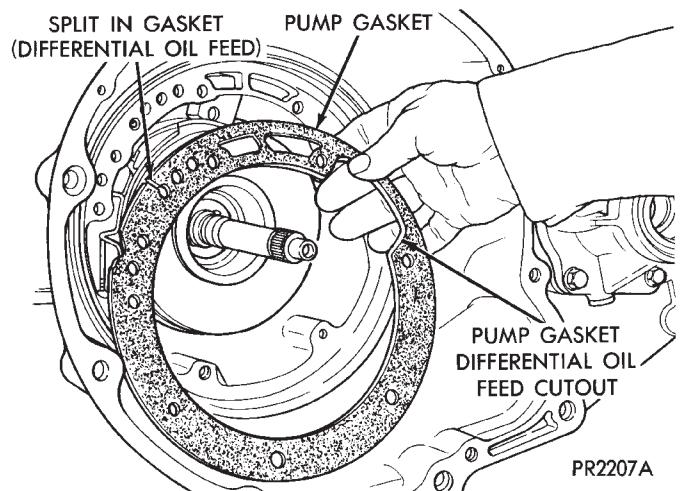

Fig. 14 Oil Pump Gasket

Record indicator reading for reference when reassembling the transaxle.

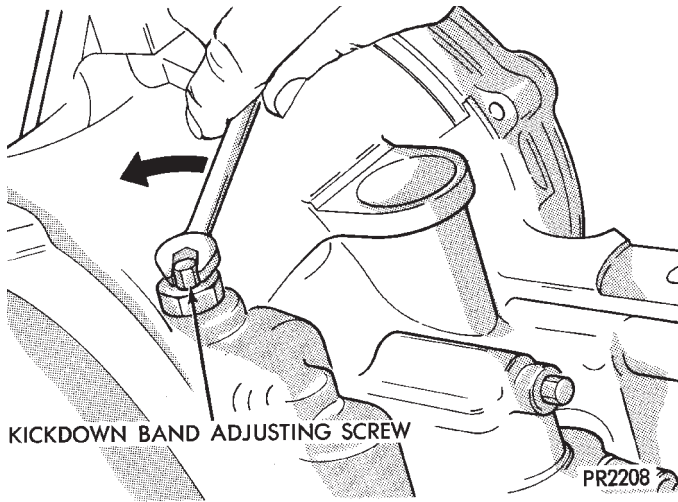

Fig. 15 Loosen Kickdown Band Adjusting Screw

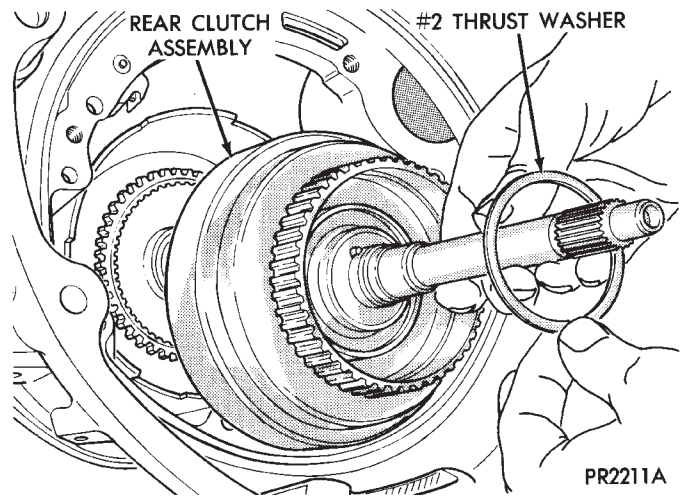

Fig. 18 No. 2 Thrust Washer and Rear Clutch

CAUTION: The input shaft for non-lockup torque converter has 2 seal rings. The lockup input shaft has three seal rings.

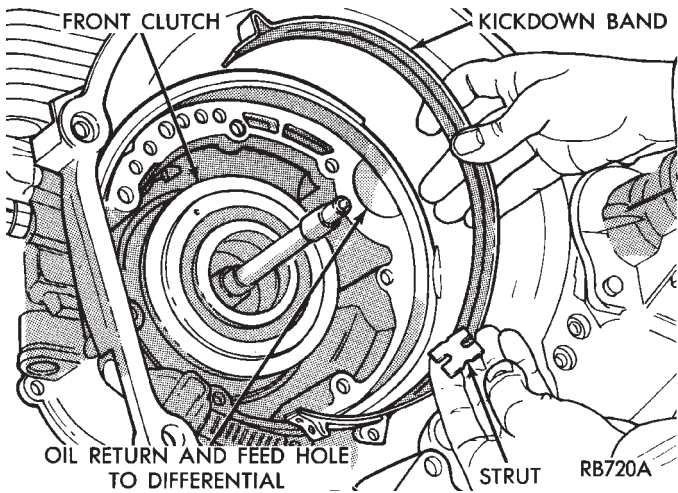

Fig. 16 Kickdown Band and Strut

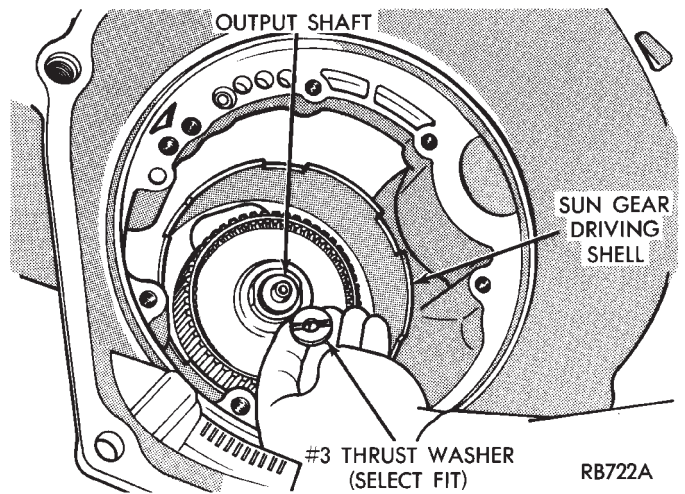

Fig. 19 No. 3 Thrust Washer

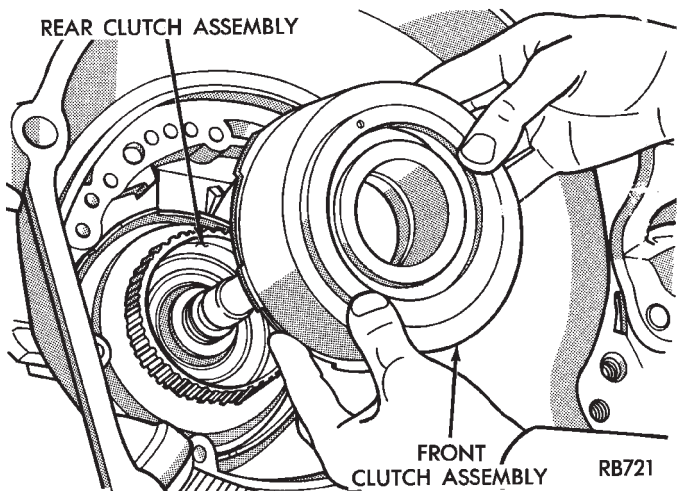

Fig. 17 Front Clutch Assembly

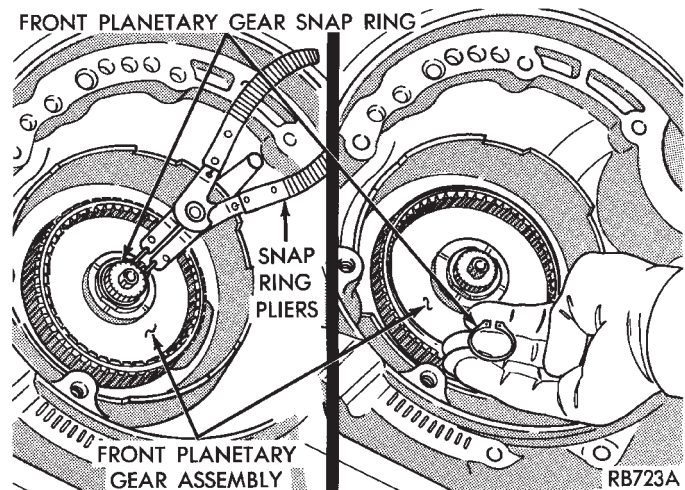

Fig. 20 Front Planetary Gear Snap Ring

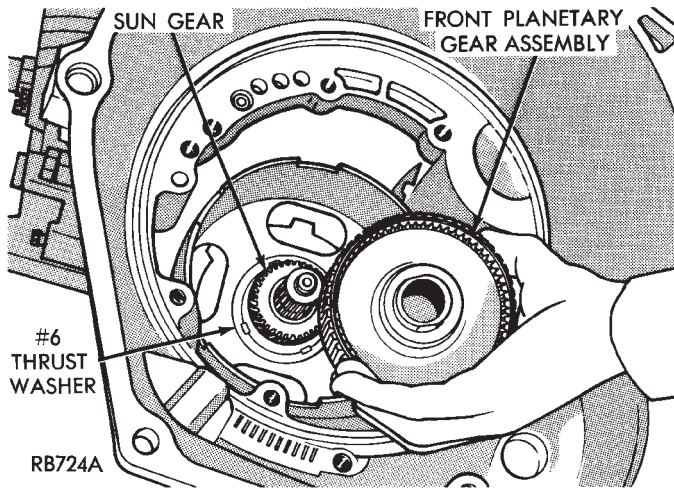

Fig. 21 Front Planetary Gear Assembly

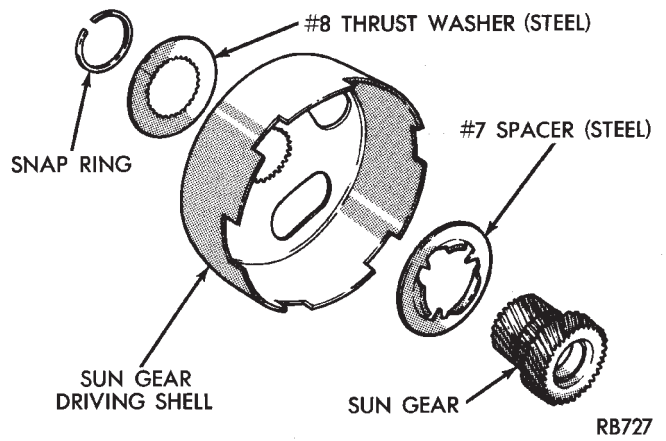

Fig. 24 Sun Gear Driving Shell Components

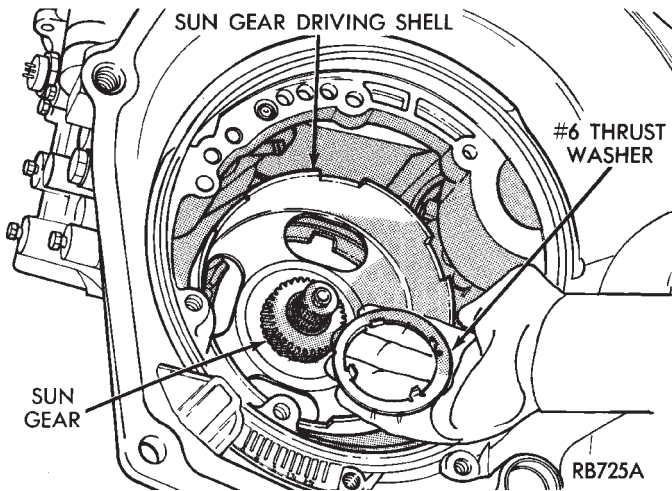

Fig. 22 No. 6 Thrust Washer

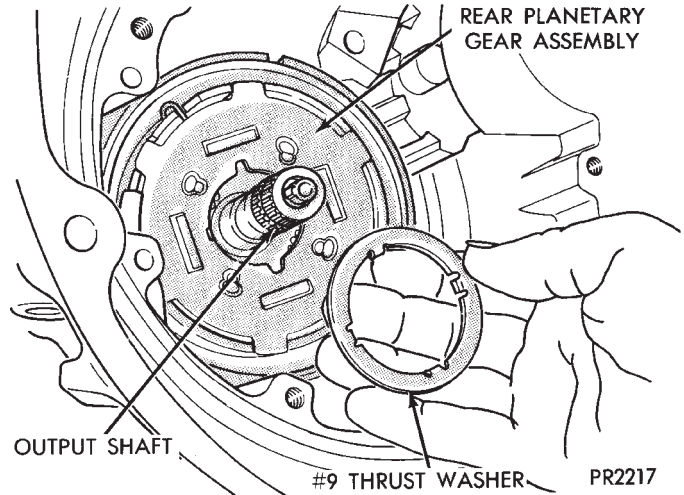

Fig. 25 No. 9 Thrust Washer

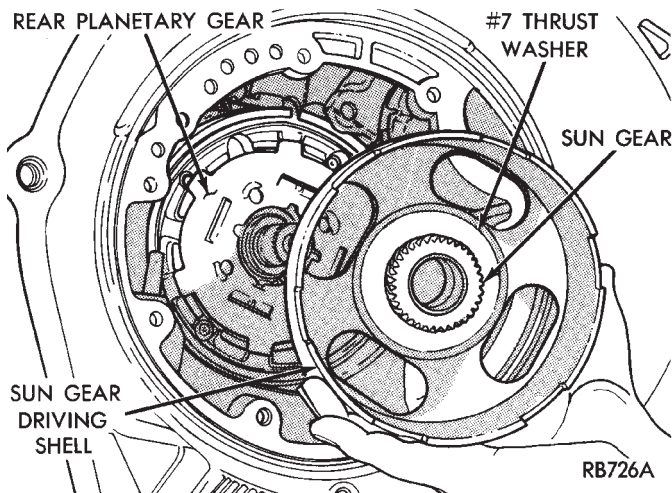

Fig. 23 Sun Gear Driving Shell

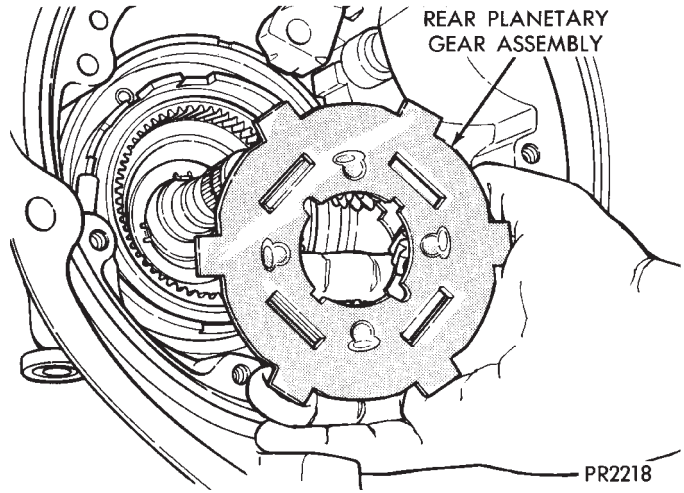

Fig. 26 Rear Planetary Gear Assembly

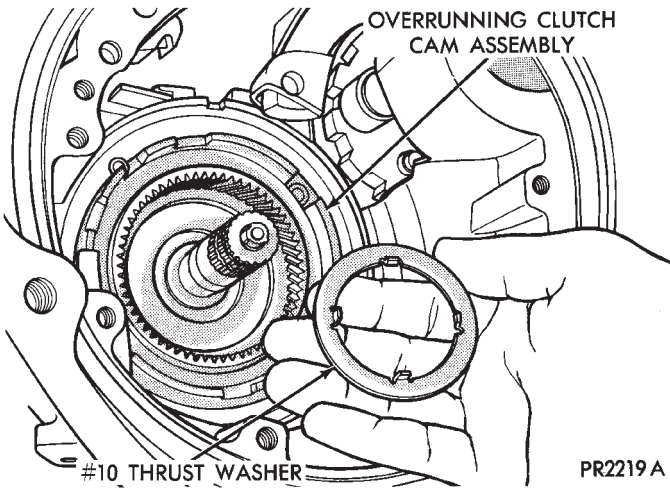

Fig. 27 No. 10 Thrust Washer

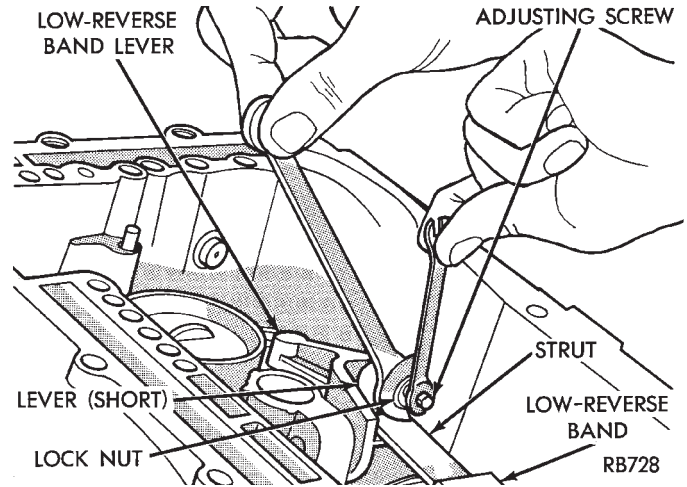

Fig. 30 Loosen or Adjust Low-Reverse Band

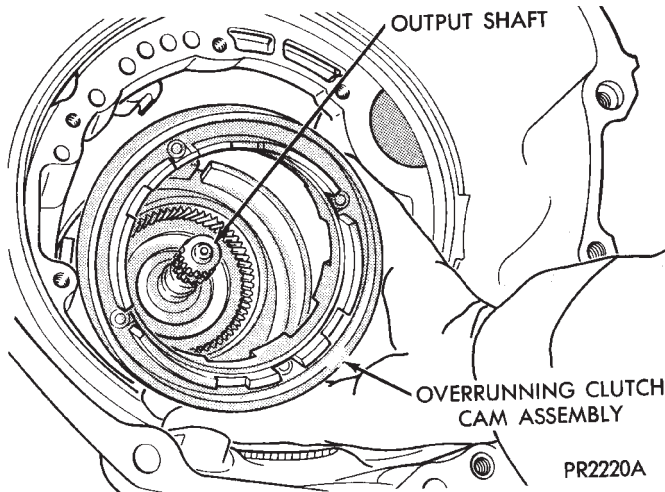

Fig. 28 Overrunning Clutch Cam Assembly

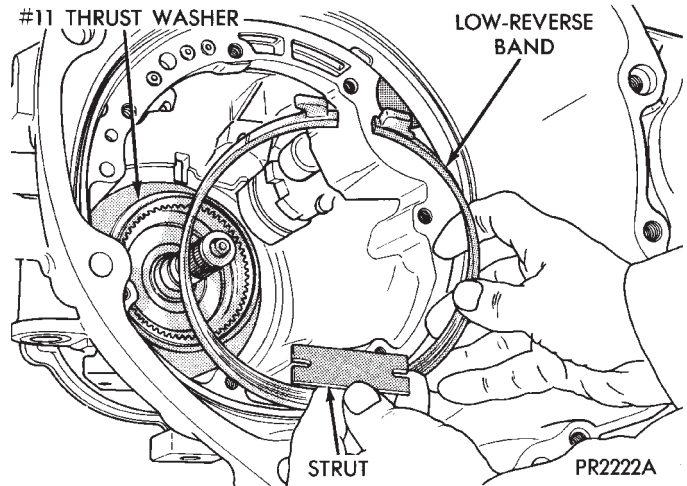

Fig. 31 Low-Reverse Band and Strut

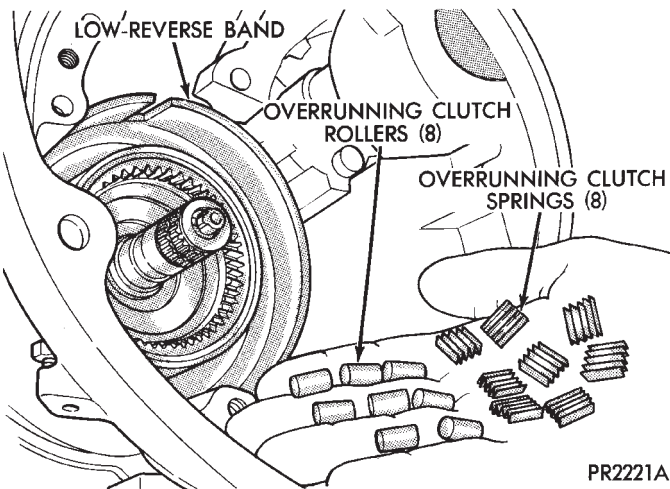

Fig. 29 Overrunning Clutch Rollers and Springs

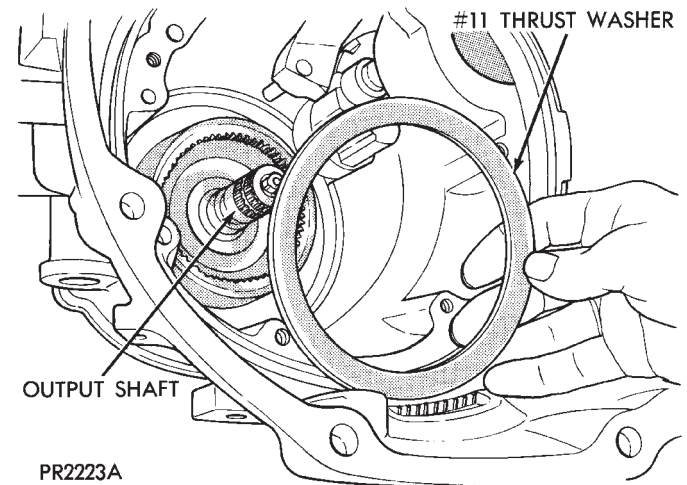

Fig. 32 No. 11 Thrust Washer

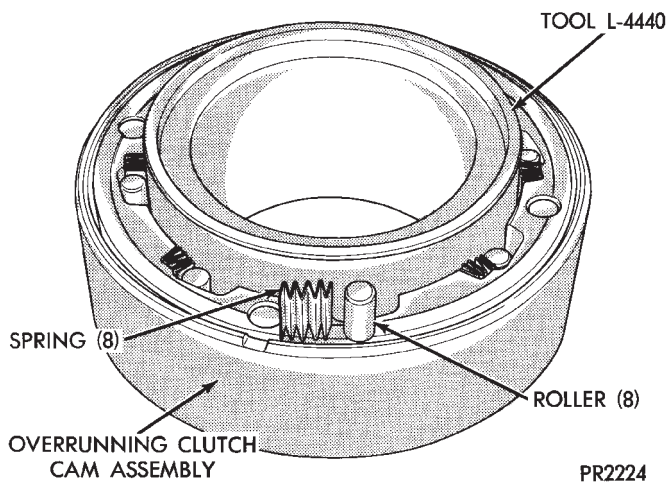

Fig. 33 Install Overrunning Clutch Rollers and Springs

TRANSAXLE ASSEMBLY (SUBASSEMBLY INSTALLATION)

When rebuilding, reverse the above procedure.

VALVE BODY RECONDITION

Tighten all valve body screws to 5 Nm (40 in. lbs.)

Do not clamp any portion of valve body or transfer plate in a vise. Any slight distortion of the aluminum body or transfer plate will result in sticking valves, excessive leakage or both. **When removing or installing valves or plugs, slide them in or out carefully. Do not use force.**

TAG ALL SPRINGS AS THEY ARE REMOVED FOR REASSEMBLY IDENTIFICATION.

CLEANING AND INSPECTION

Allow all parts to soak a few minutes in a suitable clean solvent. Wash thoroughly and blow dry with compressed air. Make sure all passages are clean and free from obstructions.

Inspect manual and throttle valve operating levers and shafts for being bent, worn or loose. If a lever is loose on its shaft, it should be replaced. Do not attempt to straighten bent levers.

Inspect all mating surfaces for burrs, nicks and scratches. Minor blemishes may be removed with crocus cloth, using only a very light pressure. Using a straightedge, inspect all mating surfaces for warpage or distortion. Slight distortion may be corrected, using a surface plate. Make sure all metering holes in steel plate are open. Using a pen light, inspect bores in valve body for scores, scratches, pits and irregularities.

Inspect all valve springs for distortion and collapsed coils. Inspect all valves and plugs for burrs, nicks, and scores. Small nicks and scores may be removed with crocus cloth, providing extreme care is taken not to round off sharp edges. The sharpness of these edges is vitally important because it prevents foreign matter from lodging between valve and valve body, thus reducing possibility of sticking. Inspect all valves and plugs for freedom of operation in valve body bores.

When bores, valves, and plugs are clean and dry, the valves and plugs should fall freely in the bores. The valve body bores do not change its dimensions with use. Therefore, a valve body that was functioning properly when vehicle was new, will operate correctly if it is properly and thoroughly cleaned. There is no need to replace valve body unless it is damaged in handling.

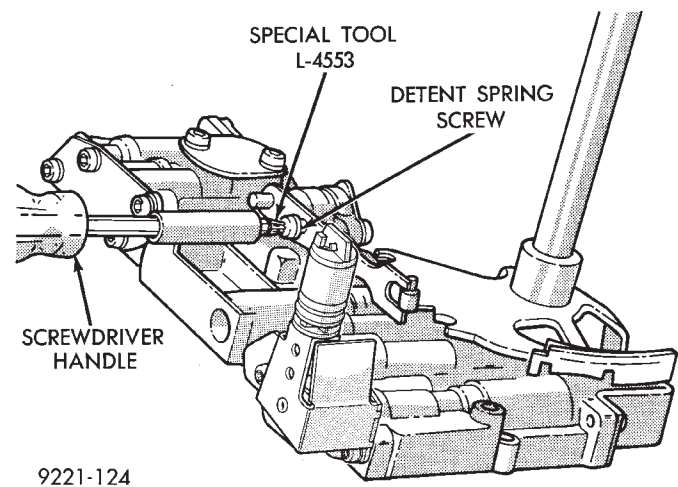

Fig. 1 Detent Spring Attaching Screw and Spring

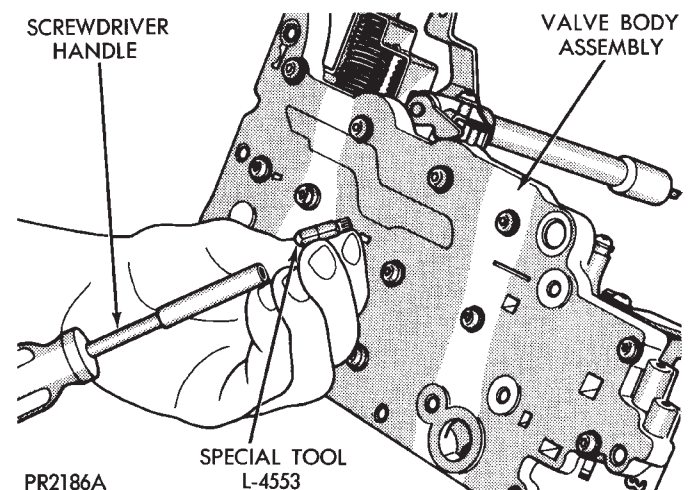

Fig. 2 Using Tool L-4553 on Valve Body Screws

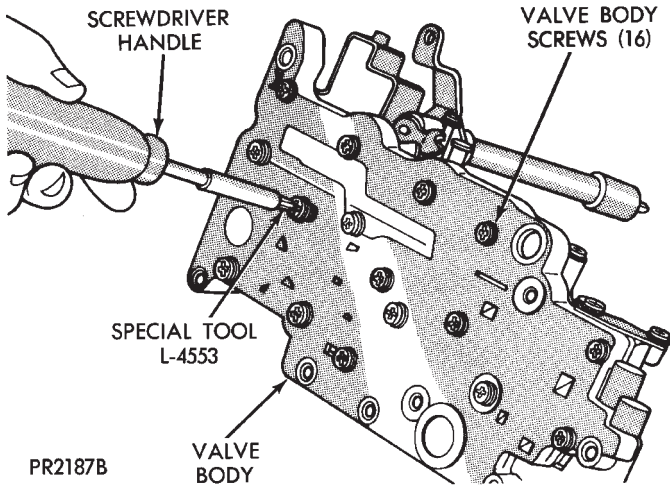

Fig. 3 Remove or Install Valve Body Screws

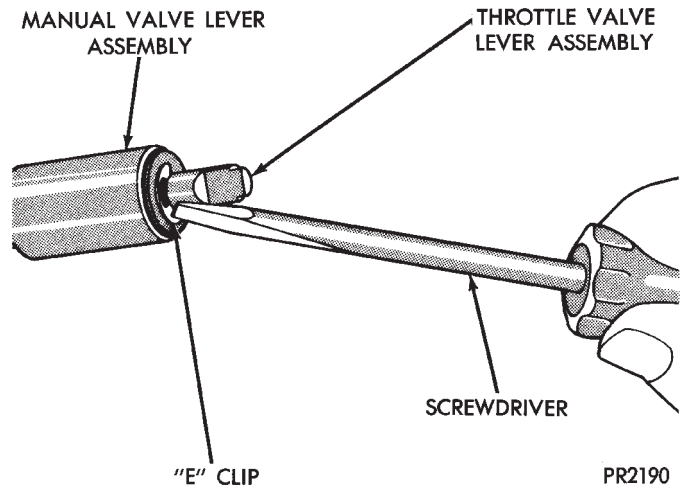

Fig. 6 Remove or Install Throttle Shaft E-Clip

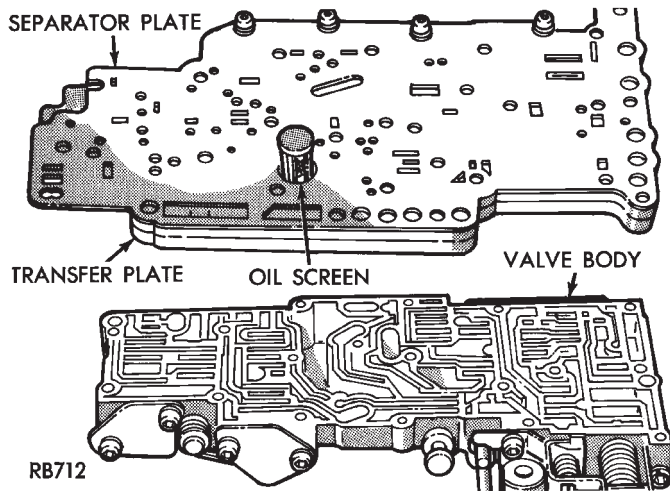

Fig. 4 Transfer Plate and Separator Plate

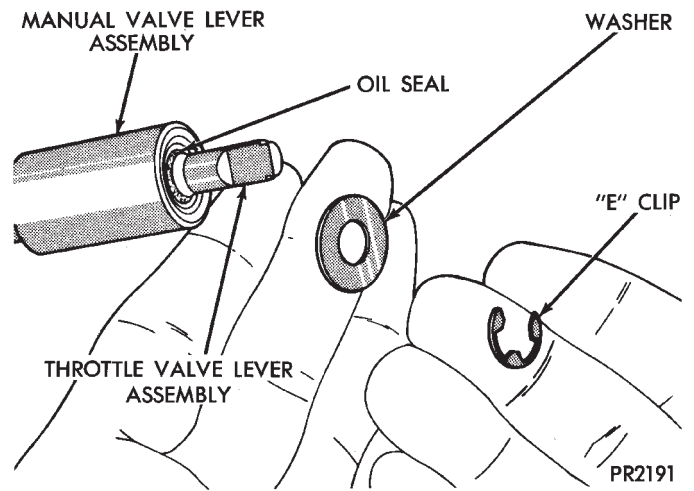

Fig. 7 Throttle Shaft E-Clip, Washer, and Seal

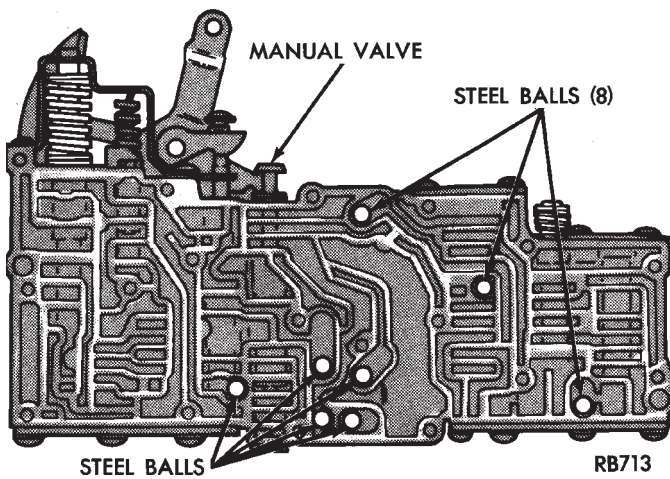

Fig. 5 Steel Ball Locations

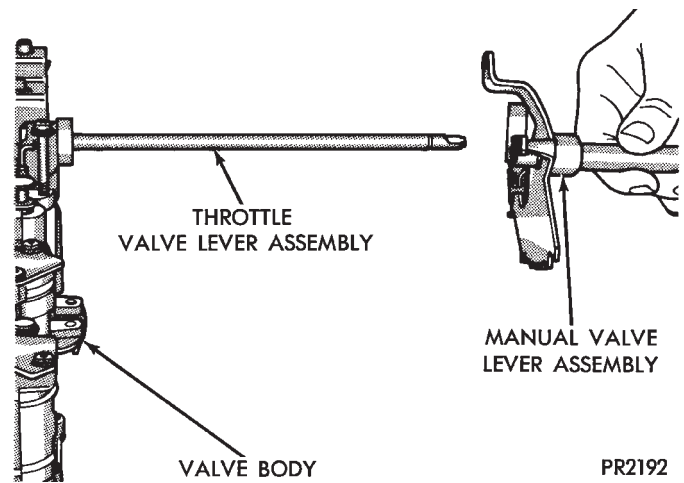

Fig. 8 Manual Valve Lever Assembly

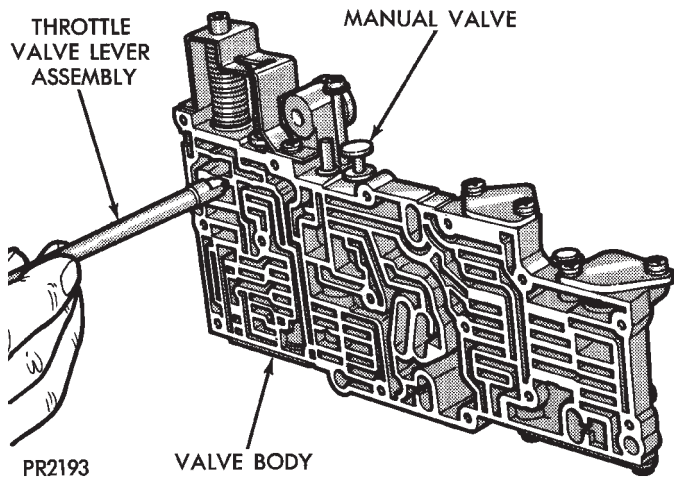

Fig. 9 Throttle Valve Lever Assembly

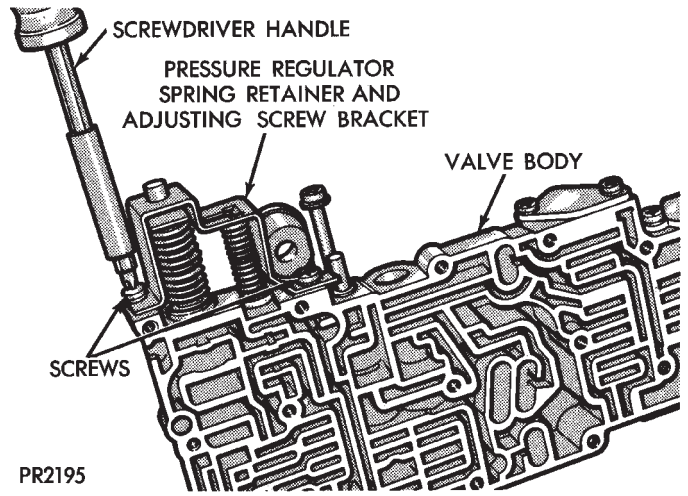

Fig. 11 Pressure Regulator and Adjusting Screw Bracket

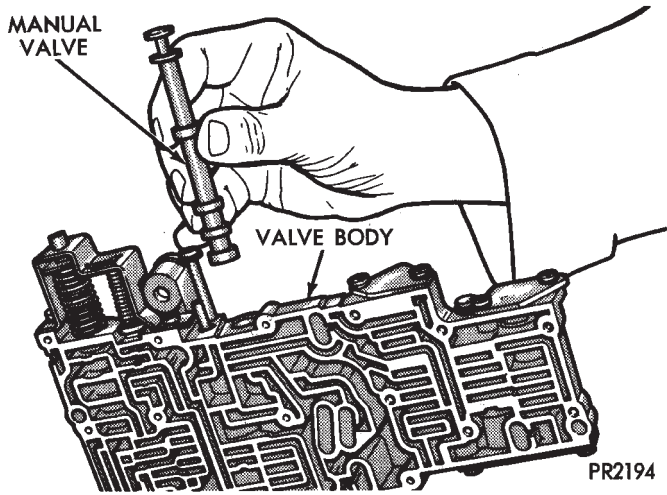

Fig. 10 Manual Valve

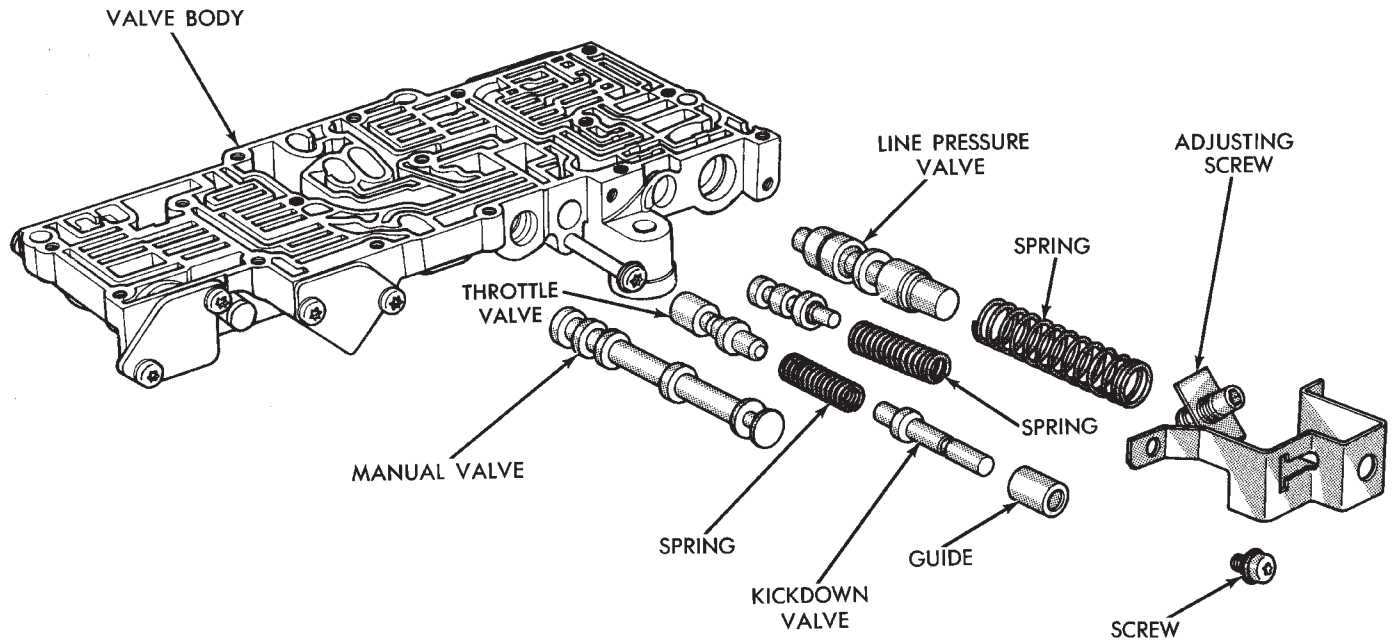
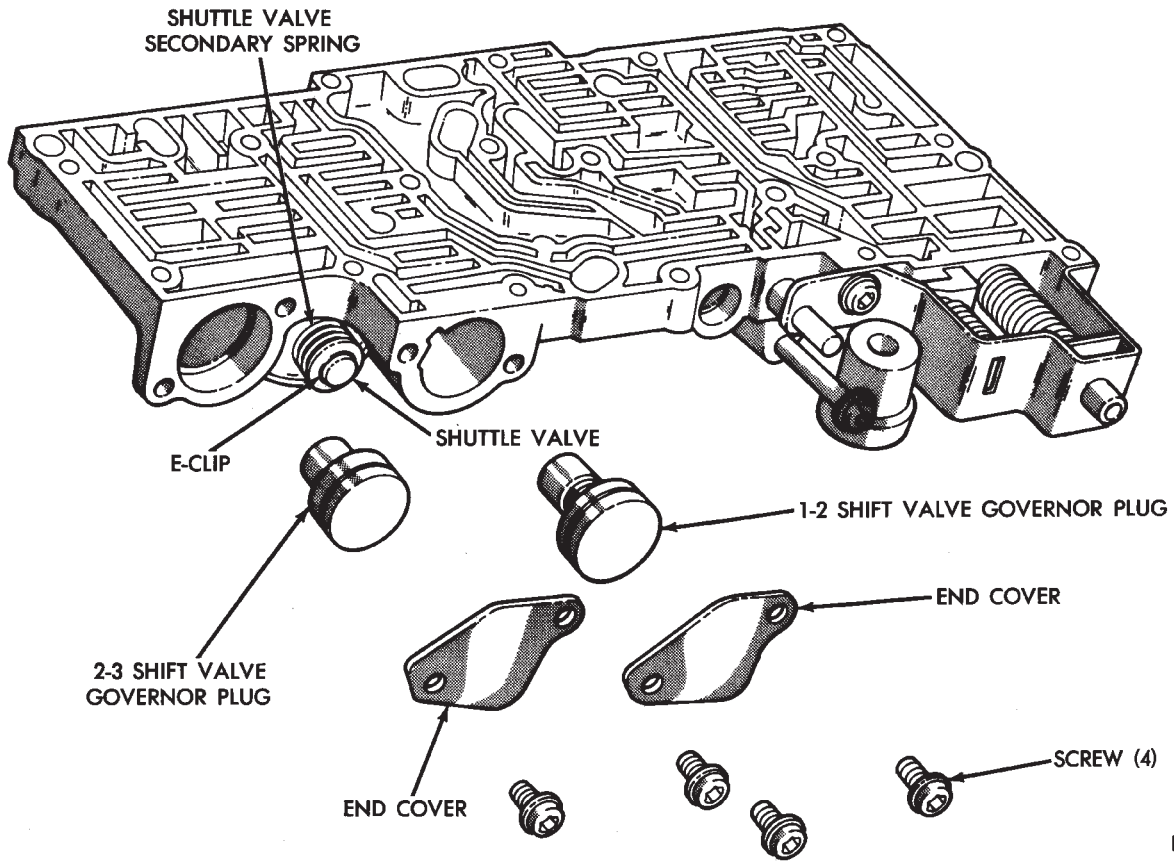

Fig. 12 Pressure Regulators and Manual Controls

PR2196A



RB714

Fig. 13 Governor Plugs

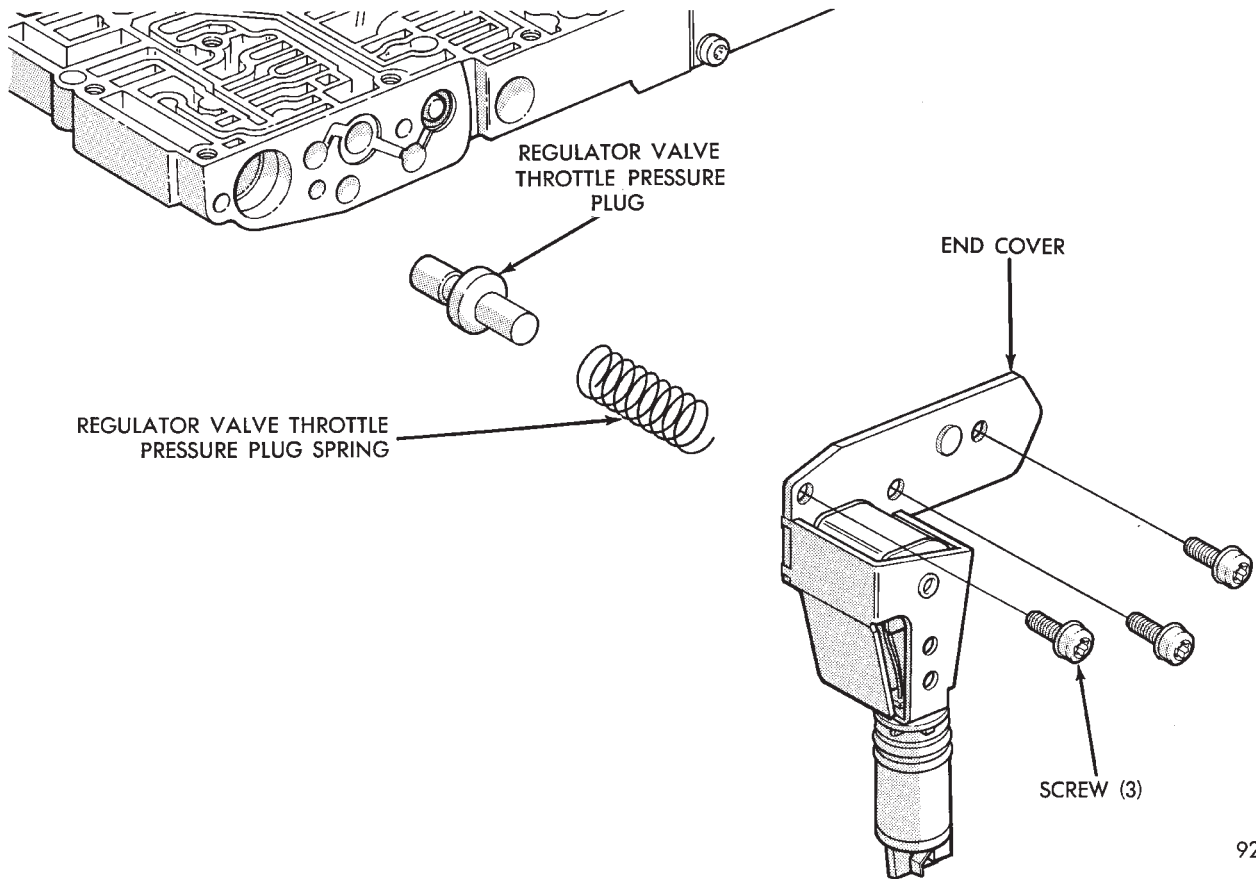

9221-125

Fig. 14 Pressure Regulator Valve Plugs

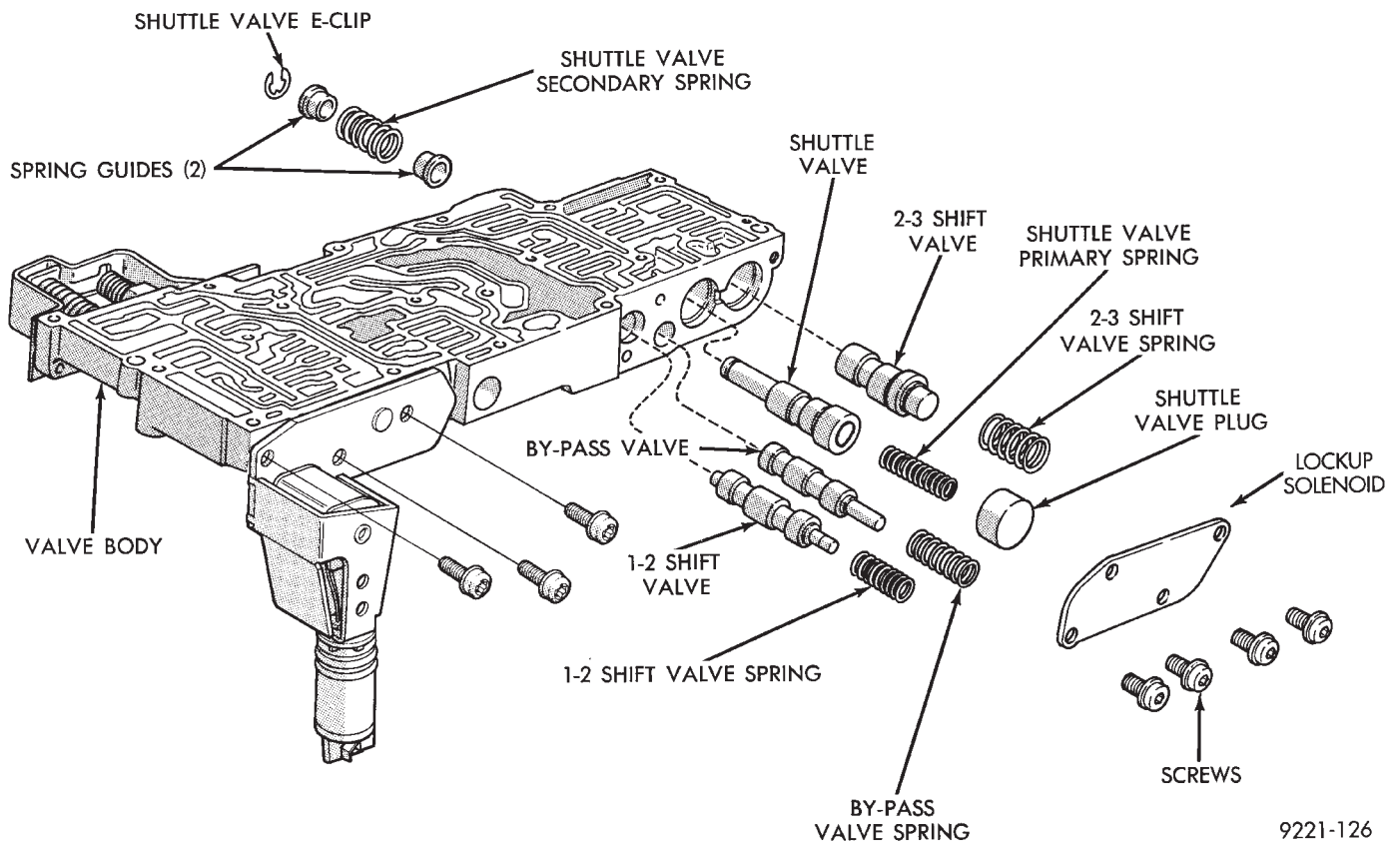

Fig. 15 Shift Valves and Shuttle Valve

PUMP OIL SEAL-REPLACEMENT

The pump oil seal can be replaced without removing the pump and reaction shaft support assembly from the transaxle case.

- (1) Screw seal remover Tool C-3981 into seal (Fig. 1), then tighten screw portion of tool to withdraw the seal.
- (2) To install a new seal, place seal in opening of the

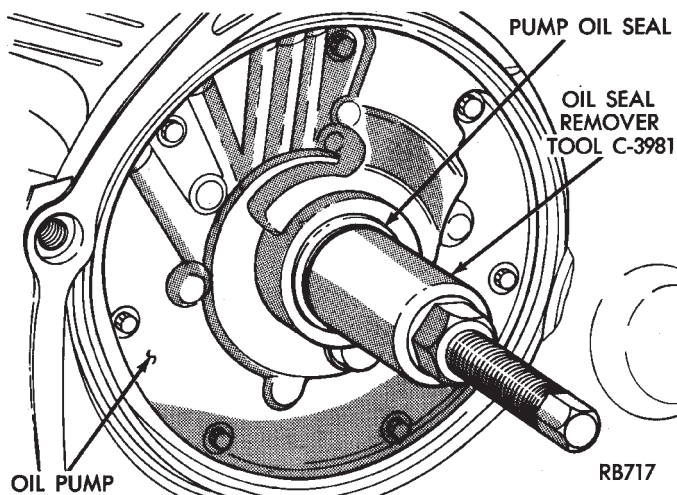

Fig. 1 Remove Pump Oil Seal

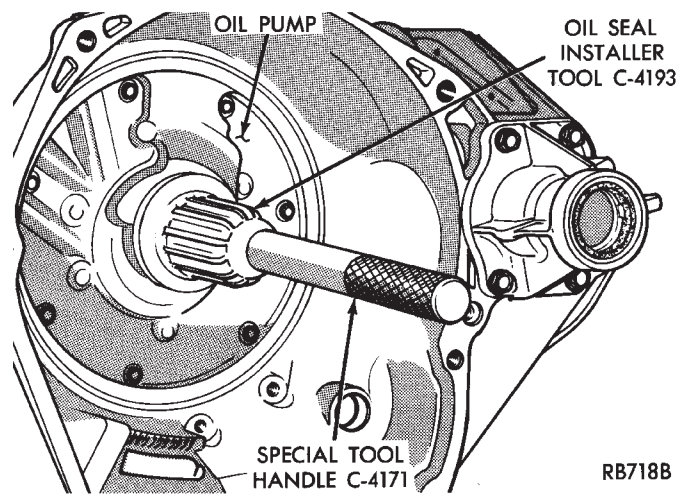

Fig. 2 Install Pump Oil Seal

pump housing (lip side facing inward). Using Tool C-4193 and Handle Tool C-4, drive new seal into housing until tool bottoms (Fig. 2).



OIL PUMP-RECONDITION

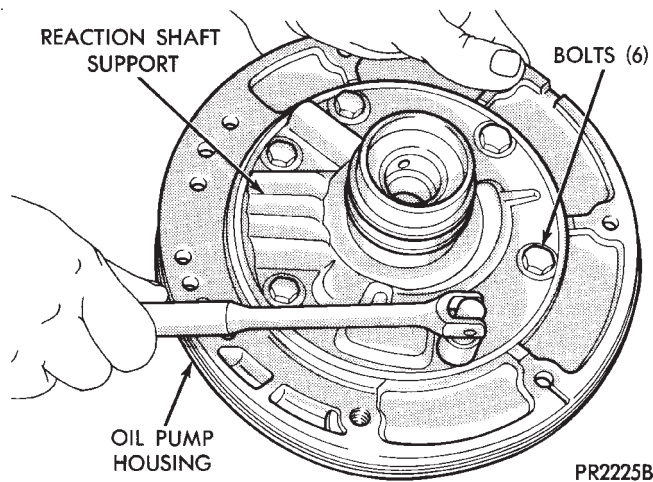

Fig. 3 Reaction Shaft Support Bolts

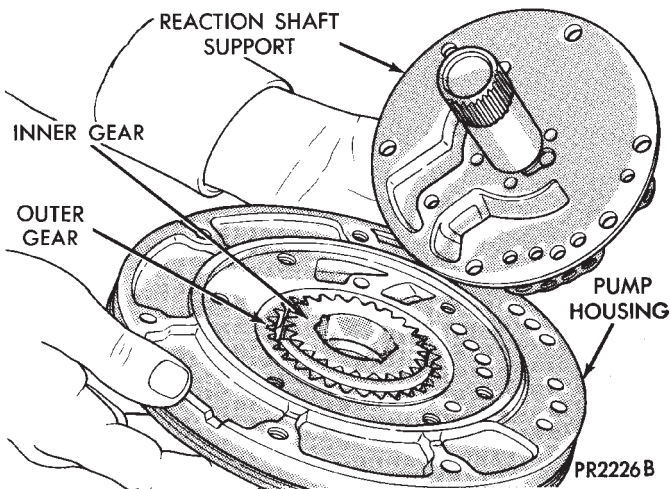

Fig. 4 Reaction Shaft Support

FRONT CLUTCH-RECONDITION

INSPECTION

Inspect plates and discs for flatness. They must not be warped or cone shaped.

Inspect facing material on all driving discs. Replace discs that are charred, glazed or heavily pitted. Discs should also be replaced if they show evidence of material flaking off or if facing material can be scraped off easily. Inspect driving disc splines for wear or other damage. Inspect steel plate surfaces for burning, scoring, or damaged driving lugs. Replace if necessary.

Also, check gear side clearance with a straight edge and a feeler gauge (See Specifications).

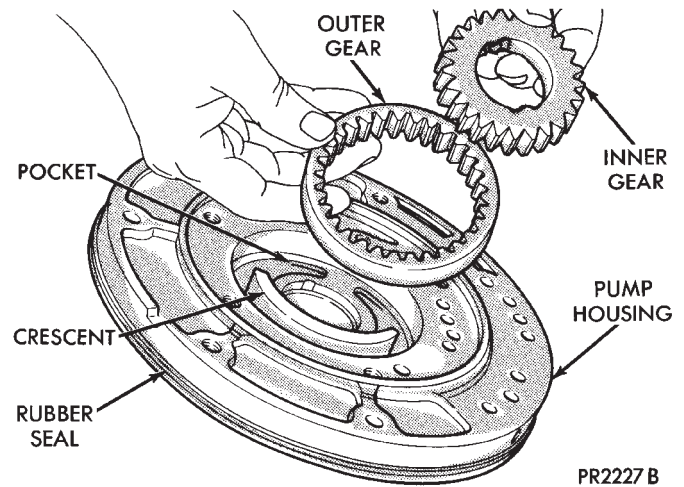

Fig. 5 Inner and Outer Pump Gears

Inspect steel plate lug grooves in clutch retainer for smooth surfaces, plates must travel freely in grooves.

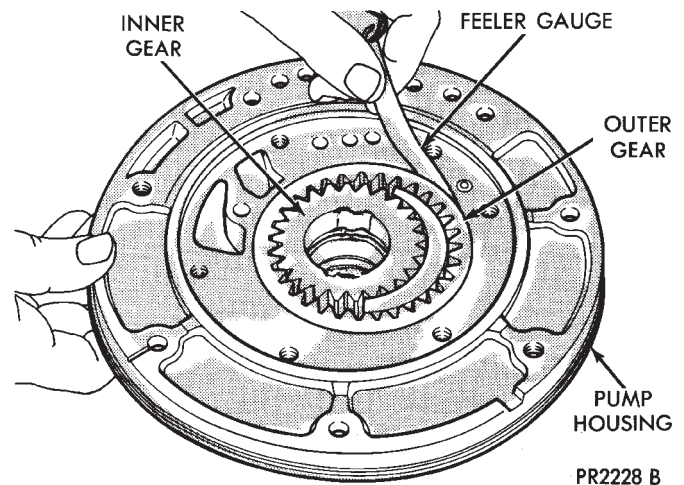

Fig. 6 Measuring Pump Clearance (Gear to Pocket)

Inspect band contacting surface on clutch retainer for scores, the contact surface should be protected from damage during disassembly and handling. Note ball check in clutch retainer, make sure ball moves freely. Inspect piston seal surfaces in clutch retainer for nicks or deep scratches, light scratches will not interfere with sealing of seals. Inspect clutch retainer inner bore surface for wear from reaction shaft support seal rings. Inspect clutch retainer bushing for wear or scores.

Inspect inside bore of piston for score marks, if light, remove with crocus cloth. Inspect seal grooves for nicks and burrs. Inspect seals for deterioration, wear, and hardness. Inspect piston spring, retainer and snap ring for distortion.



DISASSEMBLE/ASSEMBLE

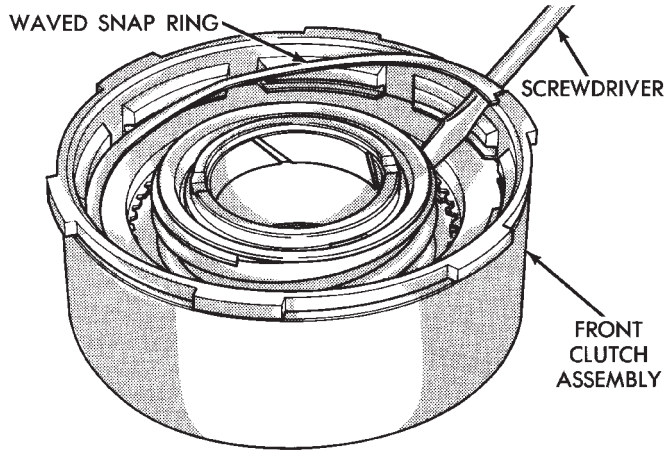

PR2229

Fig. 1 Front Clutch Waved Snap Ring

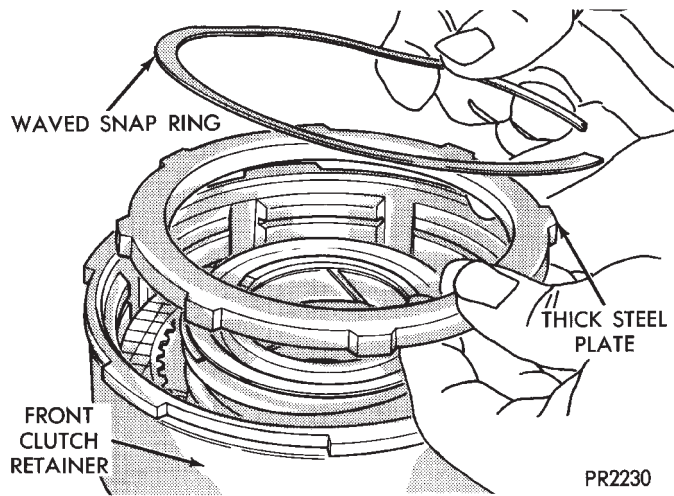

PR2230

Fig. 2 Thick Steel Plate and Waved Snap Ring

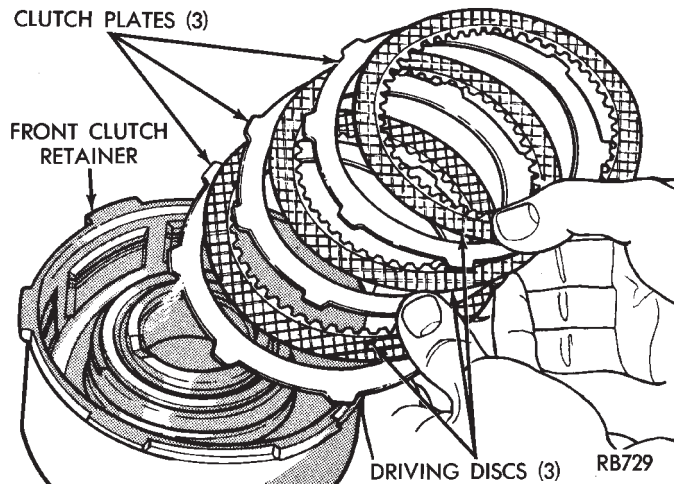

RB729

Fig. 3 Front Clutch (3-Disc Shown)

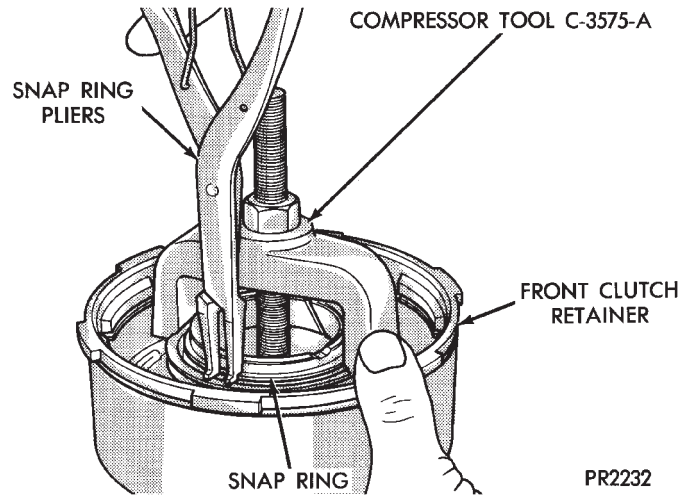

PR2232

Fig. 4 Front Clutch Return Spring Snap Ring

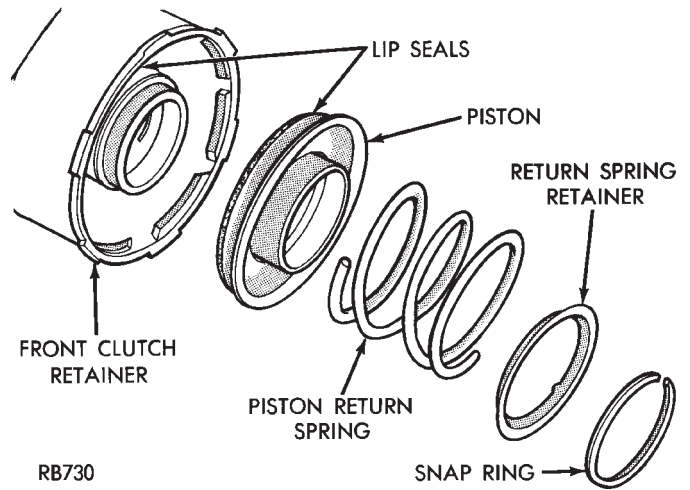

RB730

Fig. 5 Front Clutch Return Spring and Piston MEASURING PLATE CLEARANCE

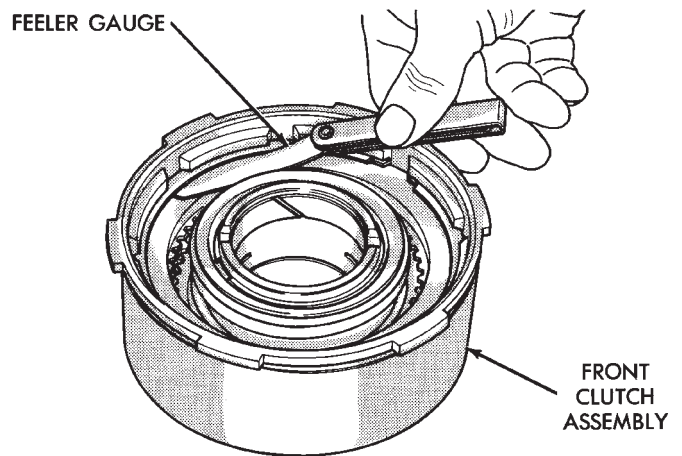

PR2234

Fig. 6 Measuring Front Clutch Plate Clearance
To reassemble, reverse the above procedure.



REAR CLUTCH-RECONDITION

INSPECTION

Inspect facing material on all driving discs. Replace discs that are charred, glazed or heavily pitted. Discs should also be replaced if they show evidence of material flaking off or if facing material can be scraped off easily. Inspect driving disc splines for wear or other damage. Inspect steel plate and pressure plate surface for burning, scoring or damaged driving lugs. Replace if necessary. Inspect plates and discs for flatness, they must not be warped or cone-shaped.

Inspect steel plate lug grooves in clutch retainer for smooth surfaces, plates must travel freely in the grooves. Note ball check in piston; make sure ball moves freely. Inspect seal rings surfaces in clutch retainer for nicks or deep scratches; light scratches will not interfere with sealing of the seals. Inspect neoprene seal rings for deterioration, wear and hardness. Inspect piston spring and waved snap ring for distortion or breakage.

Inspect teflon and/or cast iron seal rings on input shaft for wear. Do not remove rings unless conditions

warrant. Inspect rear clutch to front clutch No. 2 thrust washer for wear. Washer thickness should be .061 to .063 inch, replace if necessary.

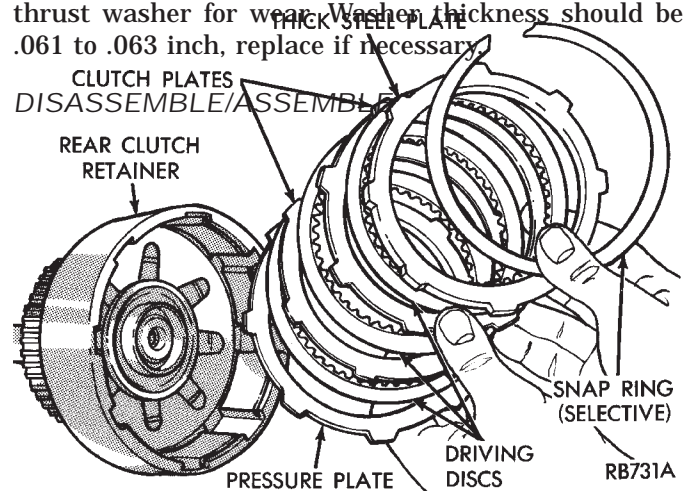

Fig. 2 Rear Clutch (3-Disc Shown)

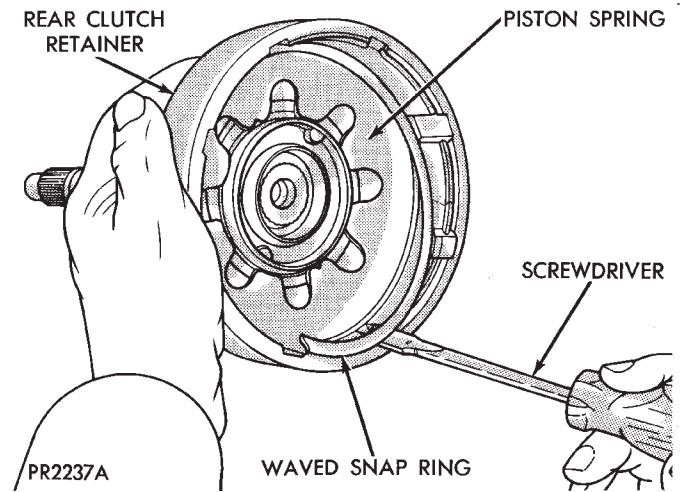

Fig. 3 Piston Spring Waved Snap Ring

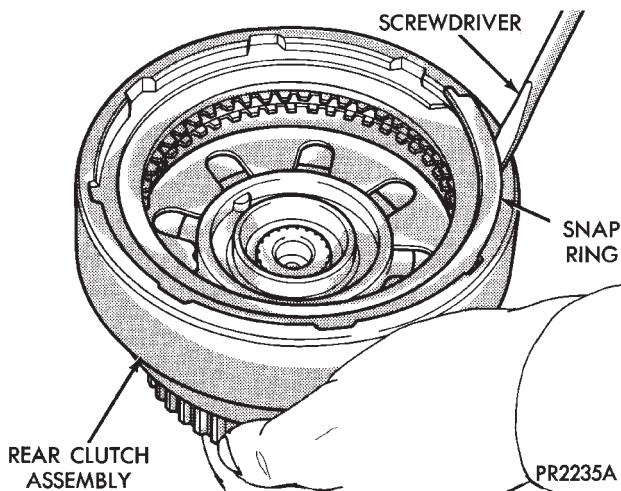

Fig. 1 Rear Clutch Outer Snap Ring

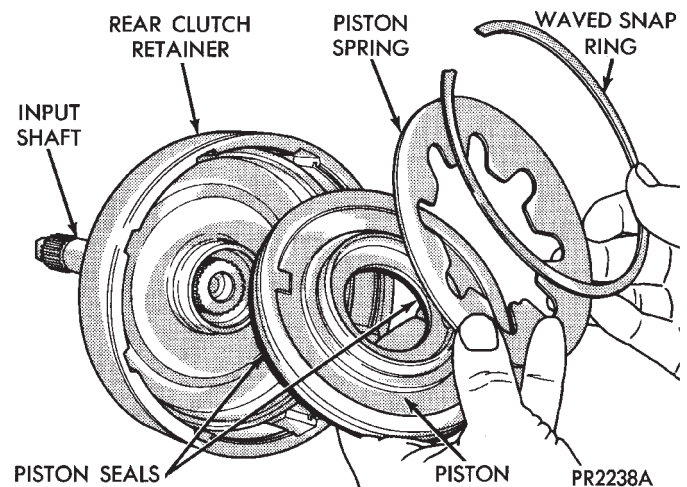

Fig. 4 Rear Clutch Piston and Piston Spring

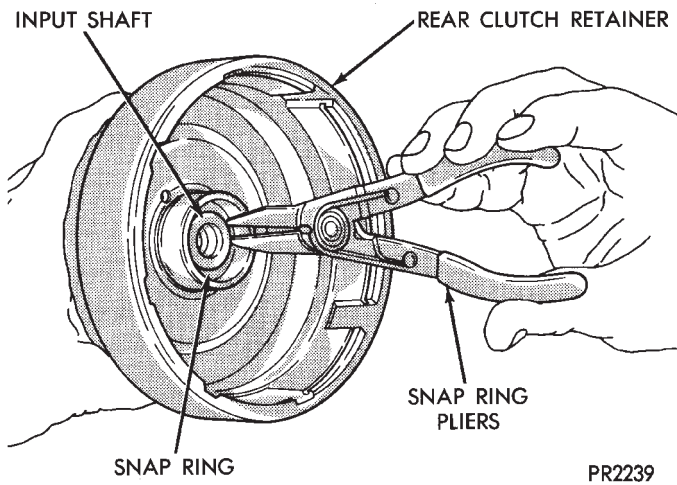

Fig. 5 Remove or Install Input Shaft Snap Ring

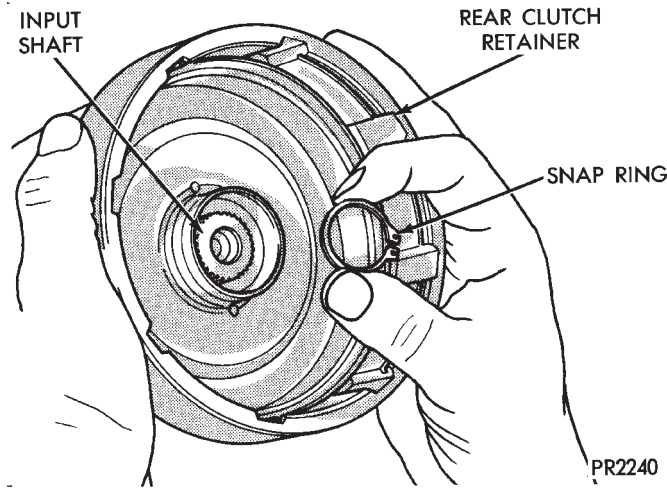

Fig. 6 Input Shaft Snap Ring

Press out input shaft, if required.
To reassemble, reverse the above procedure.

MEASURING PLATE CLEARANCE

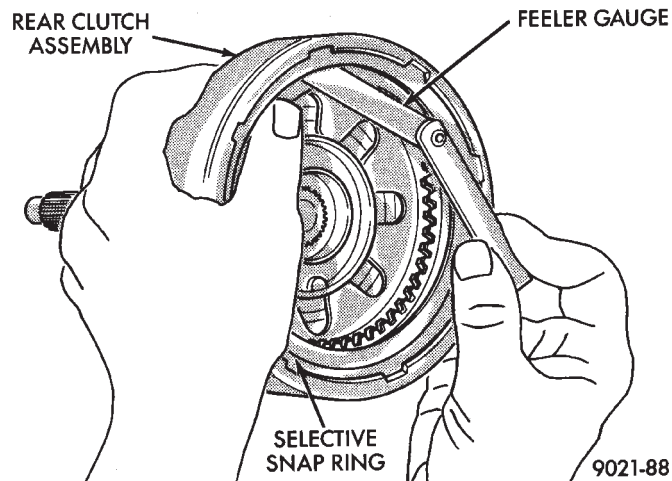

Fig. 7 Measuring Rear Clutch Plate Clearance

FRONT PLANETARY & ANNULUS GEAR-RECONDITION

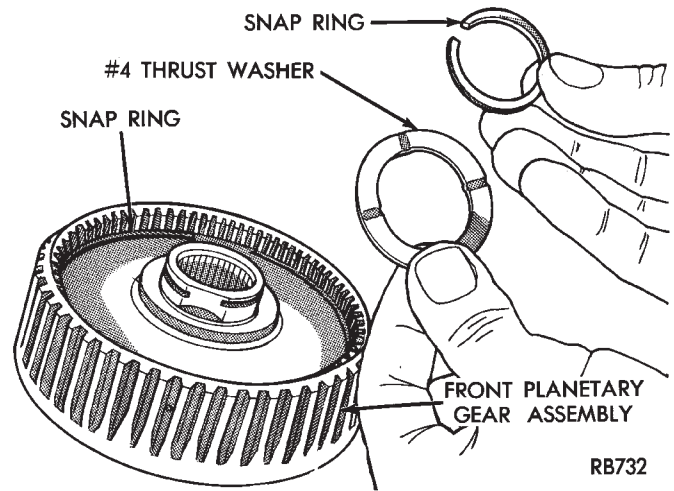

Fig. 1 Front Planetary Gear Snap Ring and No. 4 Thrust Washer (Always Install a New Snap Ring)

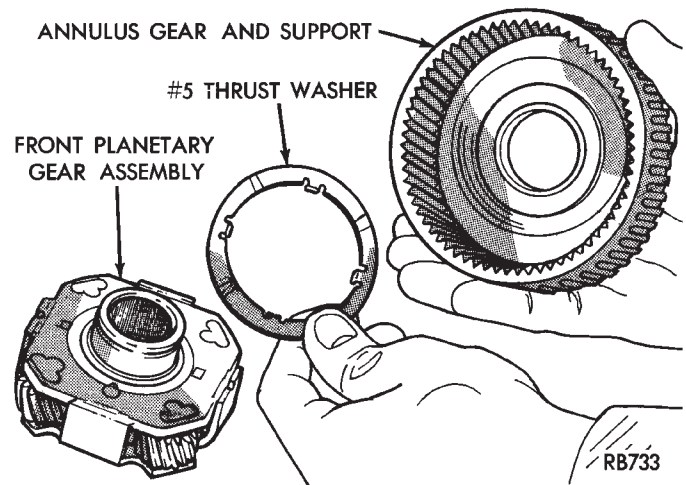

Fig. 2 Front Planetary Gear

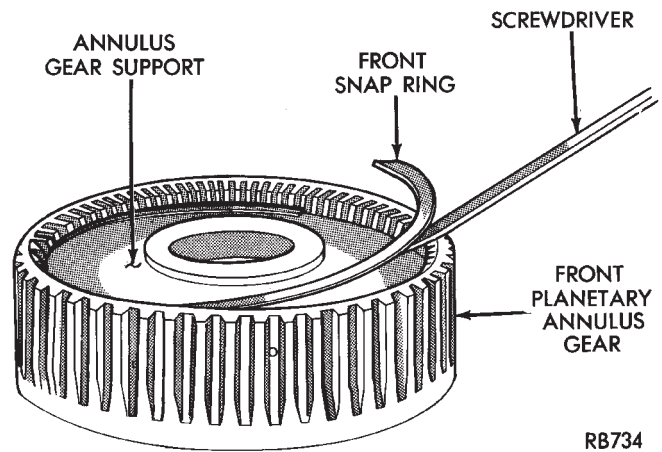

Fig. 3 Annulus Gear Support Front Snap Ring

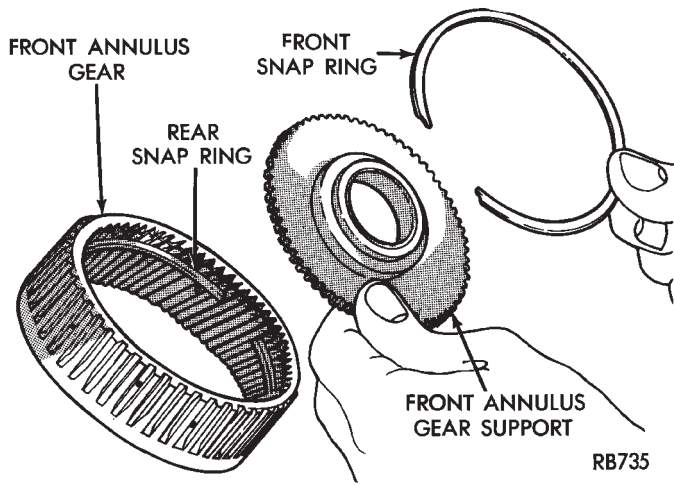

Fig. 4 Front Annulus Gear Support and Snap Ring

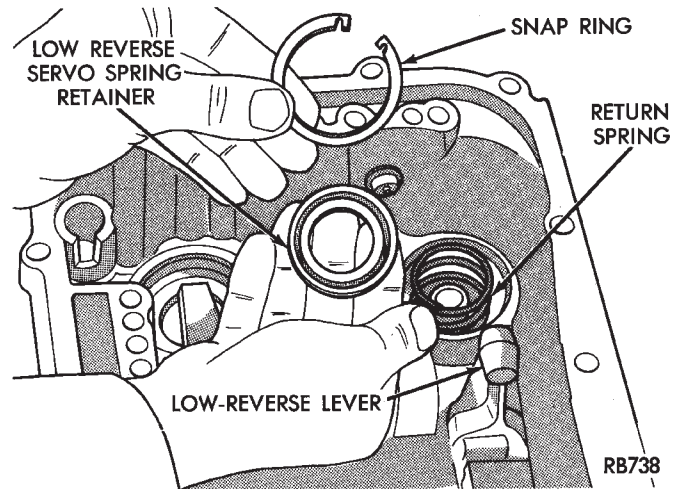

Fig. 2 Snap Ring and Retainer

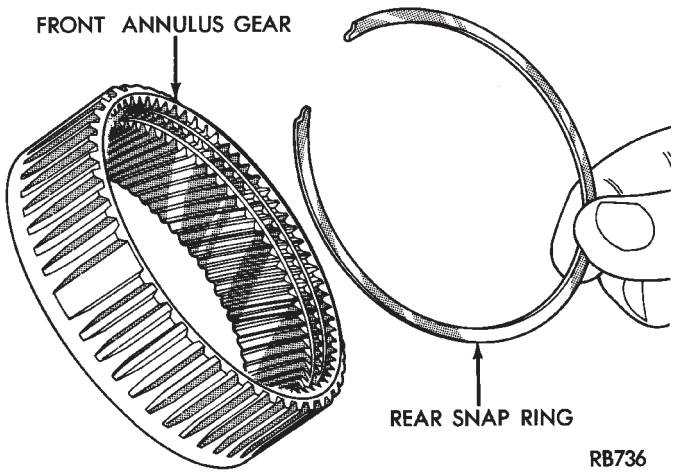

Fig. 5 Front Annulus Gear Support Snap Ring LOW/REVERSE (REAR) SERVO-RECONDITION

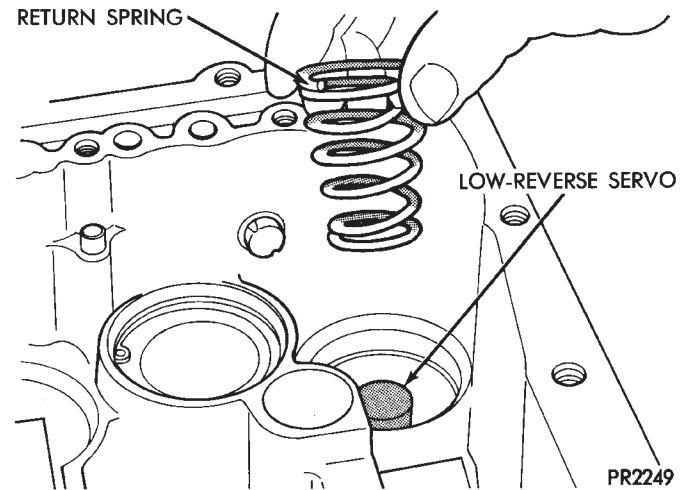

Fig. 3 Low/Reverse Servo Return Spring

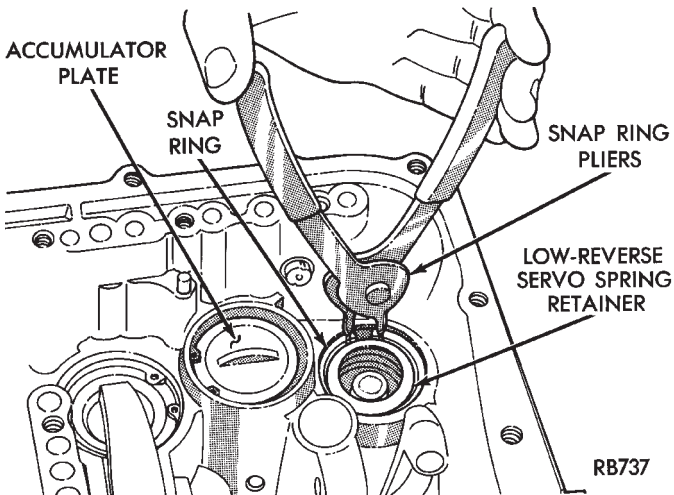

Fig. 1 Low/Reverse Servo Snap Ring

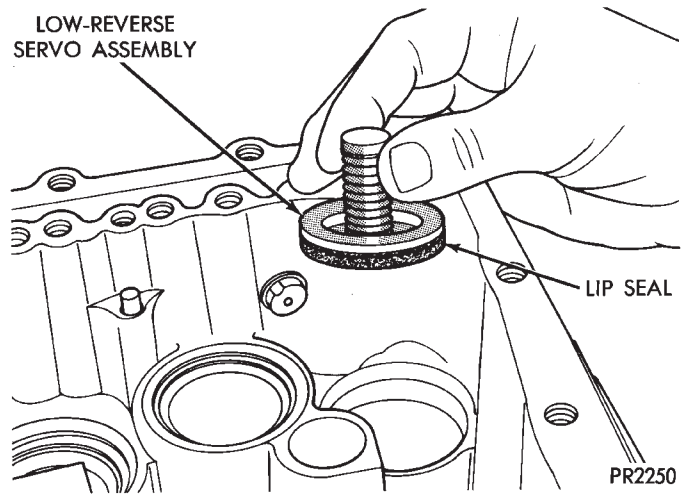

Fig. 4 Low/Reverse Servo Assembly
To assemble, reverse the above procedure.



ACCUMULATOR-RECONDITION

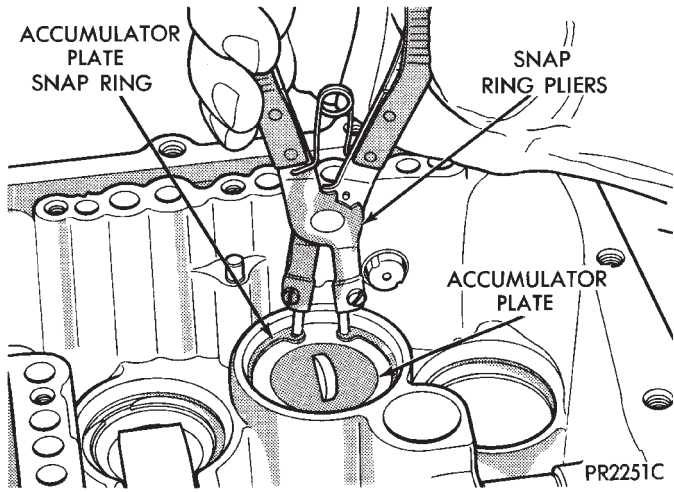

Fig. 5 Accumulator Snap Ring

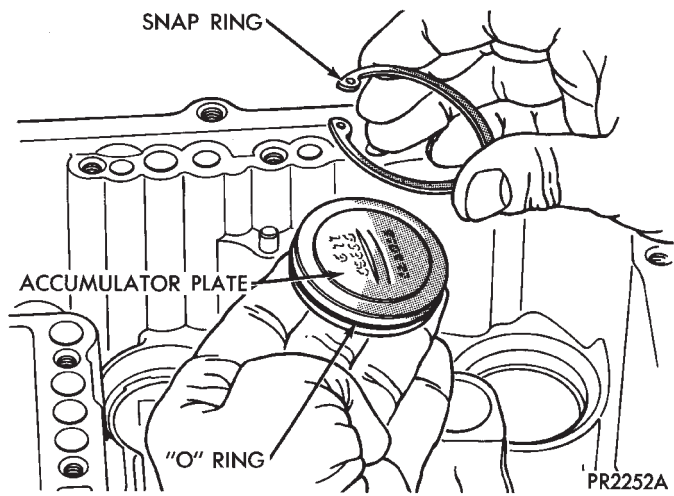

Fig. 6 Accumulator Plate and Snap Ring

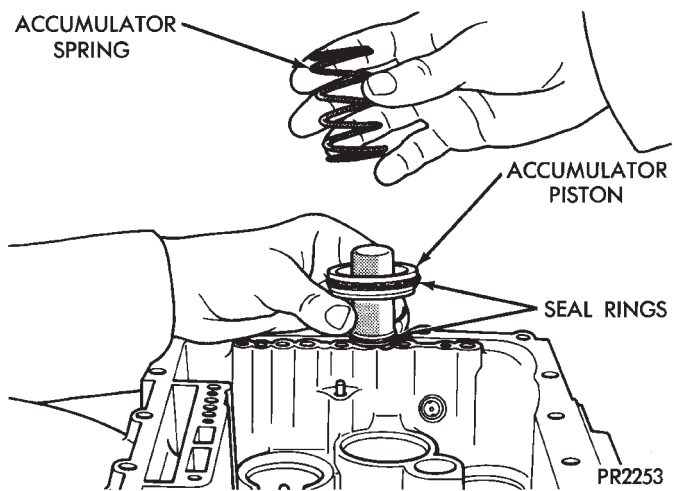

Fig. 7 Accumulator Spring and Piston

To assemble, reverse the above procedure.

KICKDOWN SERVO (CONTROLLED LOAD)-RECONDITION

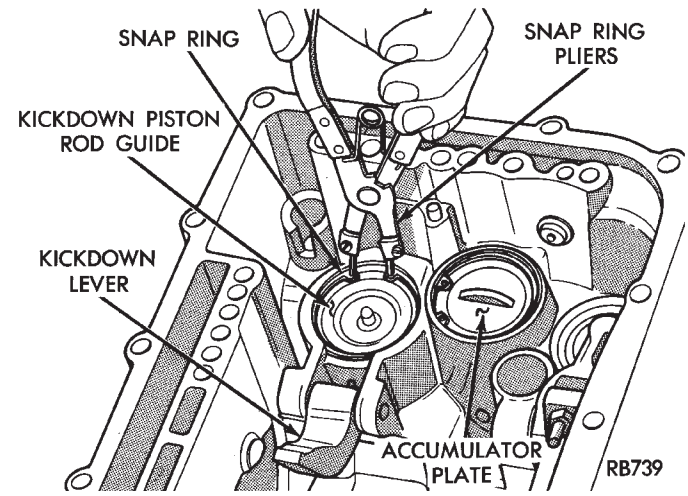

Fig. 8 Kickdown Servo Snap Ring

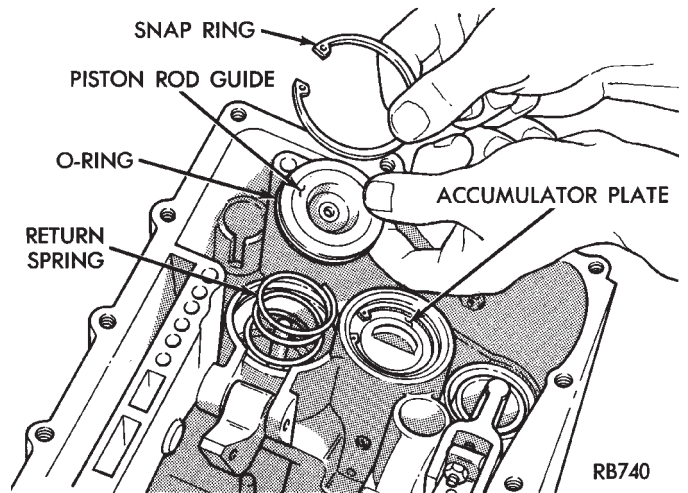

Fig. 9 Kickdown Servo Rod Guide and Snap Ring

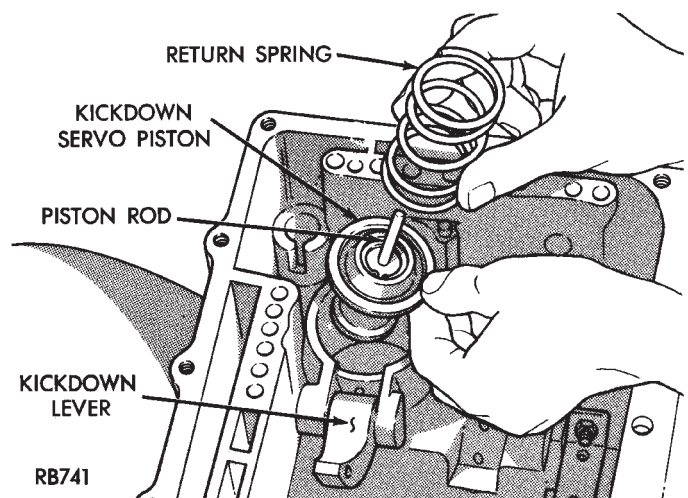

Fig. 10 Kickdown Piston Return Spring and Piston

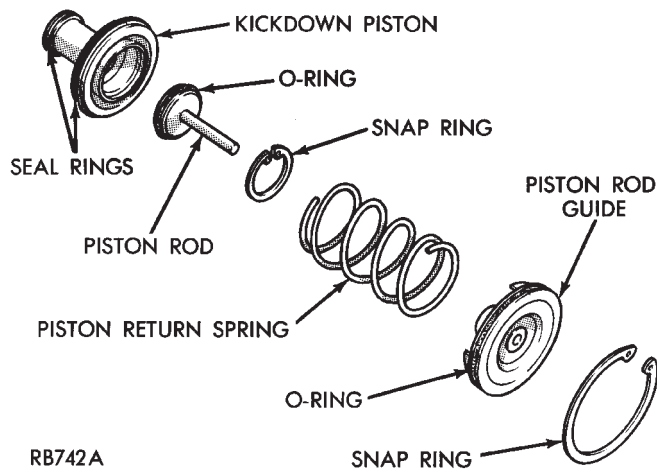

Fig. 11 Controlled Load Kickdown Servo

To assemble, reverse the above procedure.

TRANSFER SHAFT REPAIR

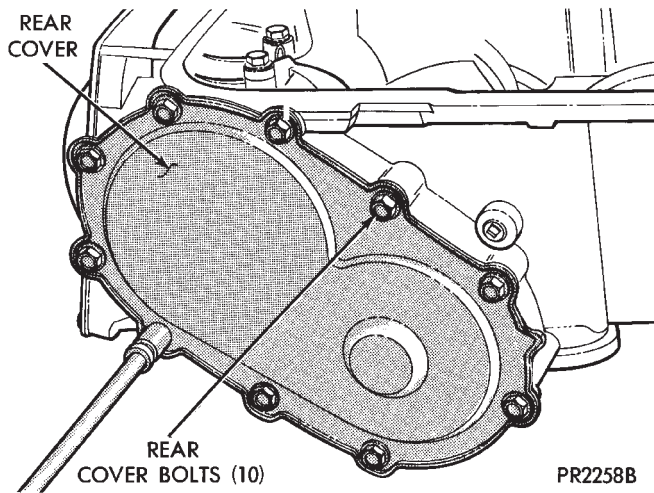

Fig. 1 Rear Cover Bolts

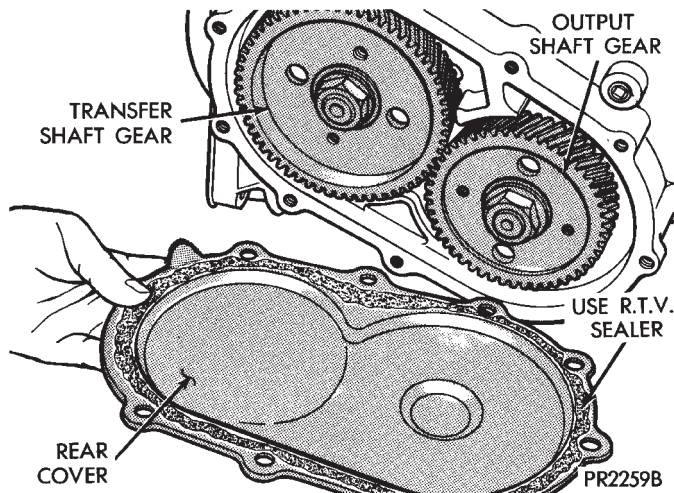

Fig. 2 Remove or Install Rear Cover

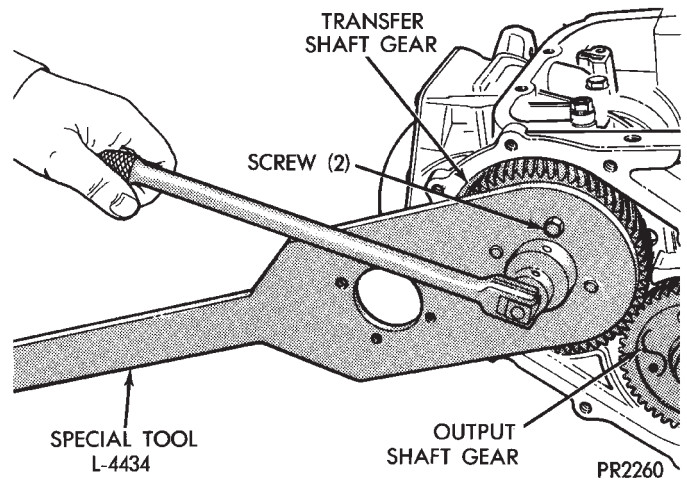

Fig. 3 Remove Transfer Shaft Gear Retaining Nut

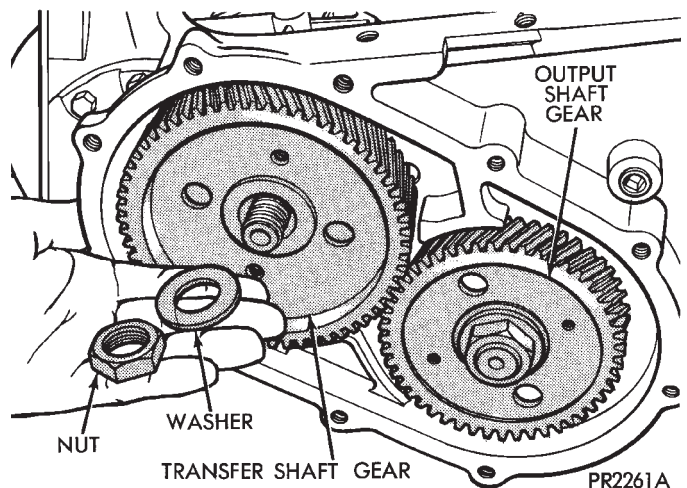

Fig. 4 Transfer Shaft Gear Nut and Washer

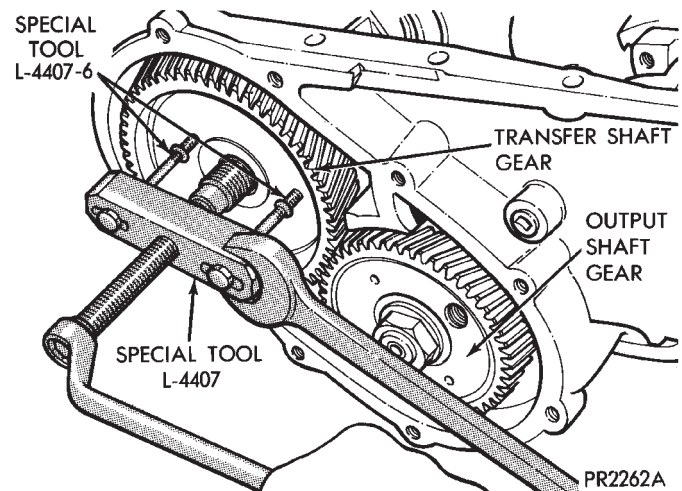

Fig. 5 Remove Transfer Shaft Gear

Remove old sealant before applying new sealant. Use Mopar® Silicone Rubber Adhesive Sealant when installing cover.

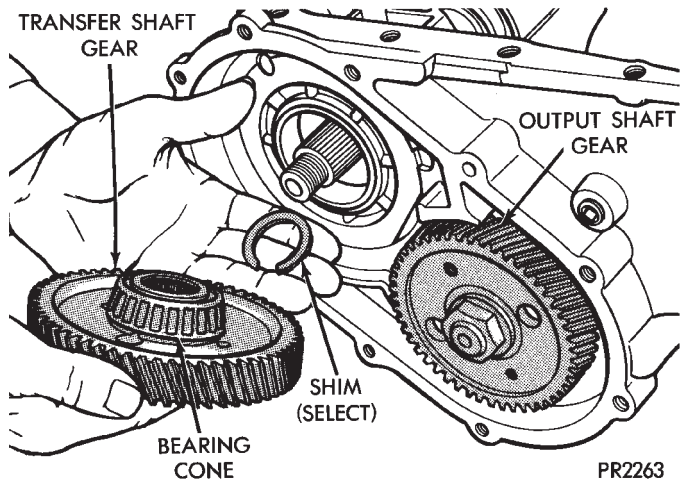

Fig. 6 Transfer Shaft Gear and (Select) Shim

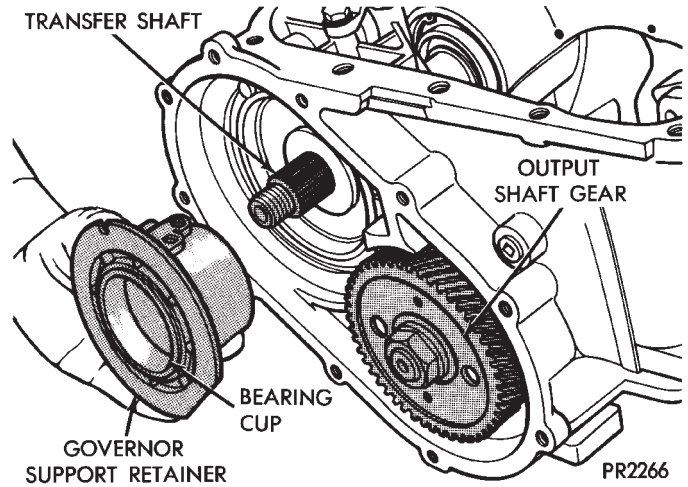

Fig. 9 Governor Support Retainer

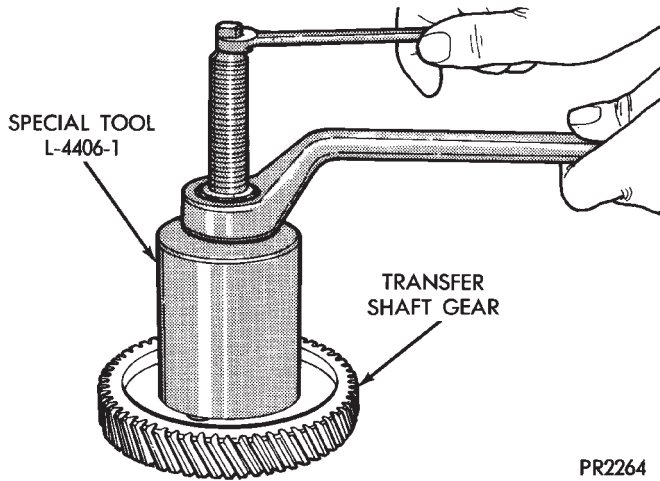

Fig. 7 Using Tool L-4406-1 with Adapter L-4406-3, Remove Transfer Shaft Gear Bearing Cone

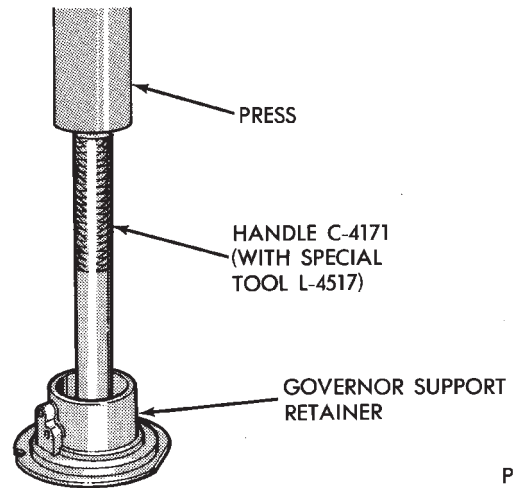

Fig. 10 Remove Governor Support Retainer Bearing Cup

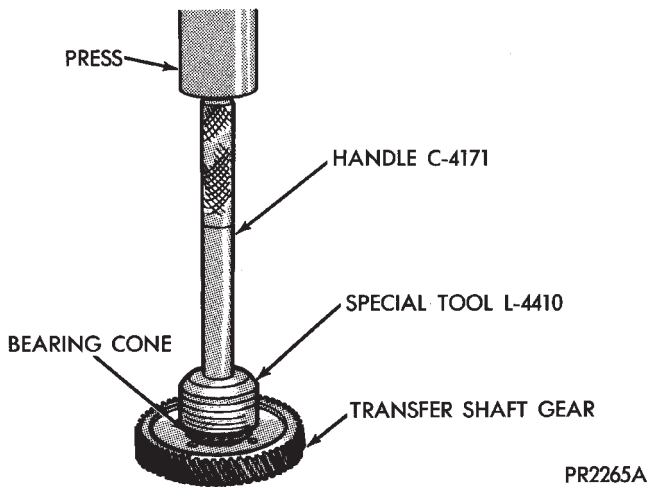

Fig. 8 Install Transfer Shaft Gear Bearing Cone

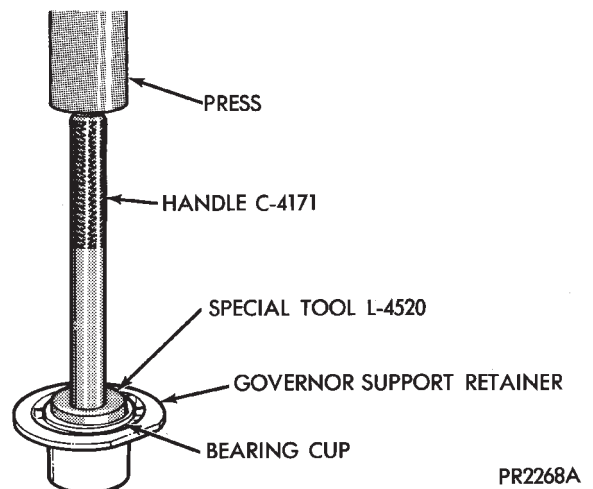

Fig. 11 Install Governor Support Retainer Bearing Cup

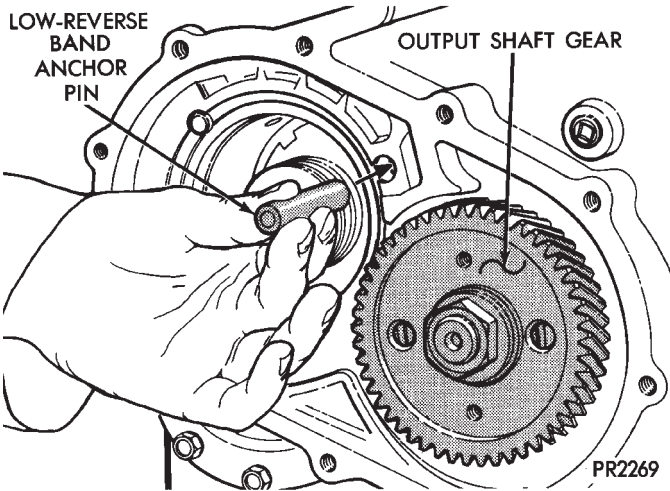

Fig. 12 Low-Reverse Band Anchor Pin

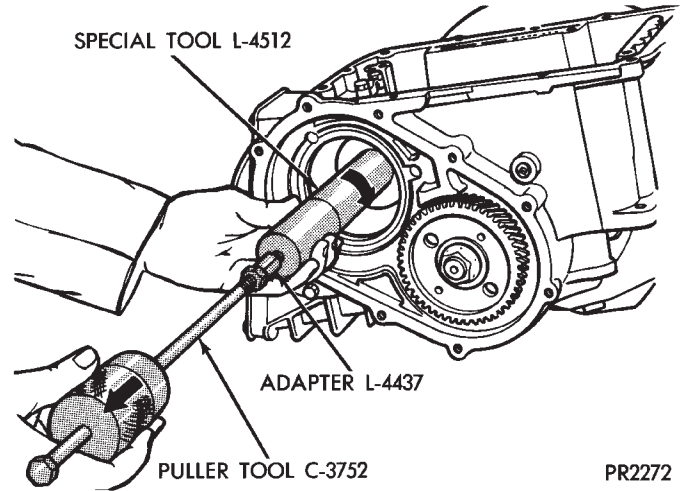

Fig. 15 Remove Transfer Shaft and Bearing Retainer Assembly

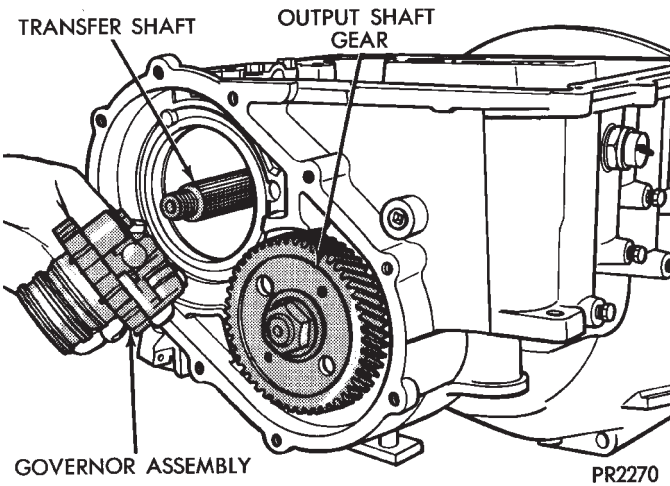

Fig. 13 Governor Assembly

Remove or install both governor valves and governor body.

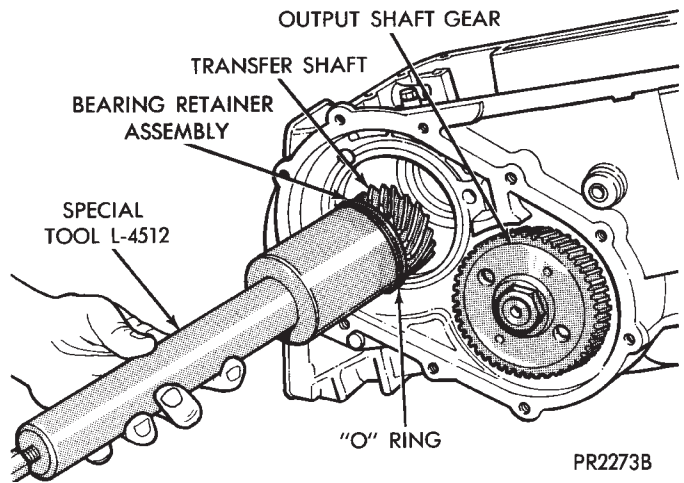

Fig. 16 Remove or Install Transfer Shaft and Bearing Retainer Assembly Using Tool L-4512

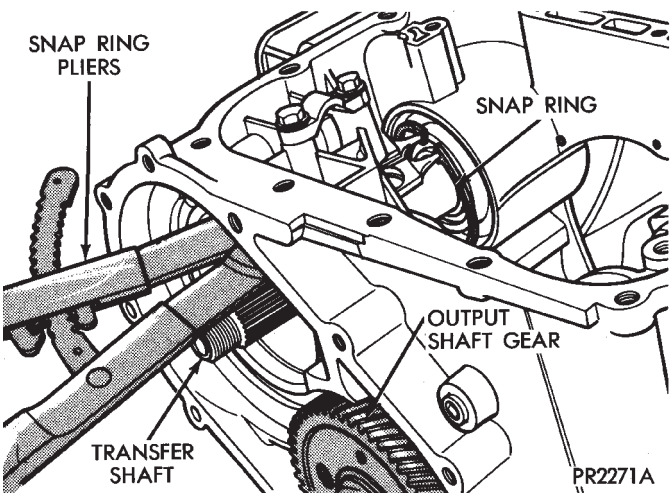

Fig. 14 Transfer Shaft Bearing Snap Ring

To install transfer shaft, reverse the above procedure.

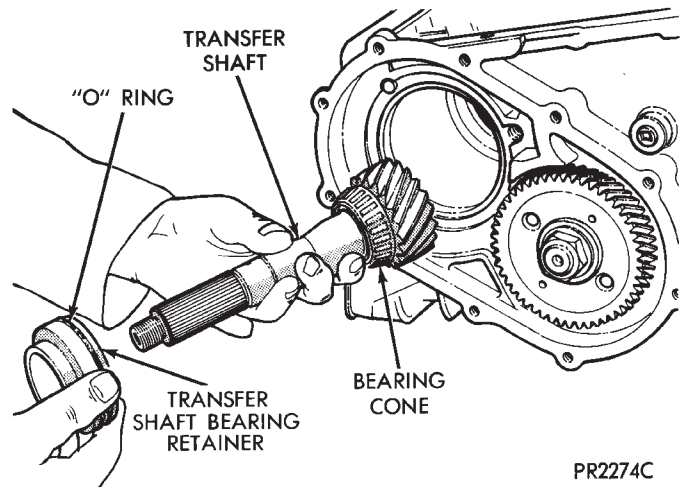
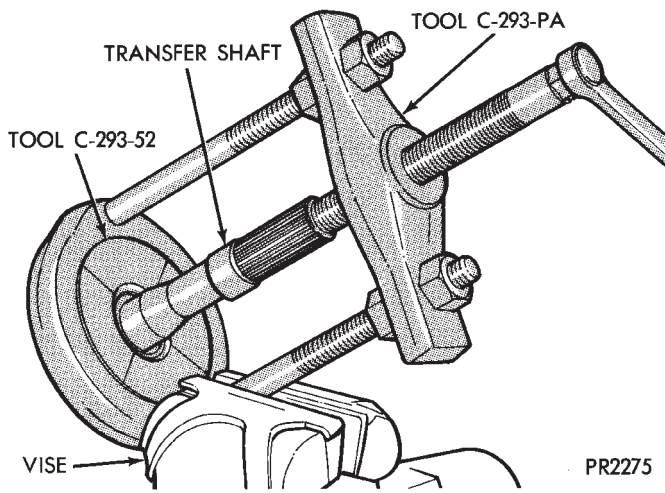
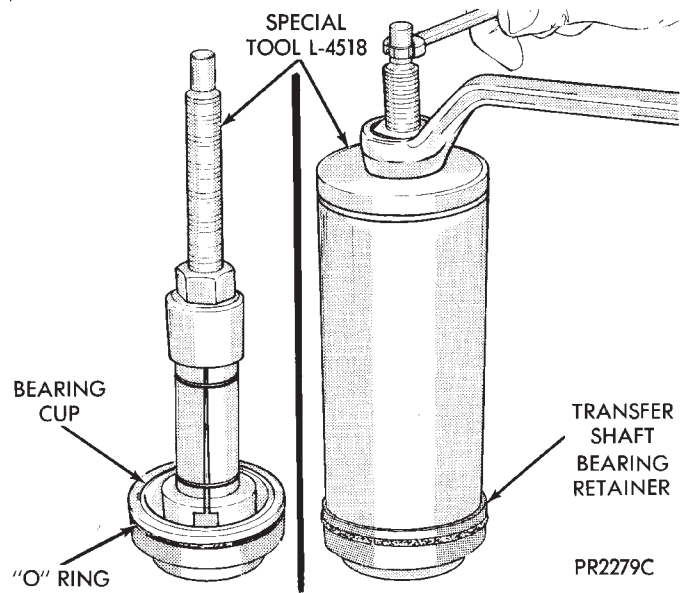

Fig. 17 Transfer Shaft and Bearing Retainer



PR2275

Fig. 18 Remove Transfer Shaft Bearing Cone



PR2279C

Fig. 20 Remove Transfer Shaft Bearing Cup

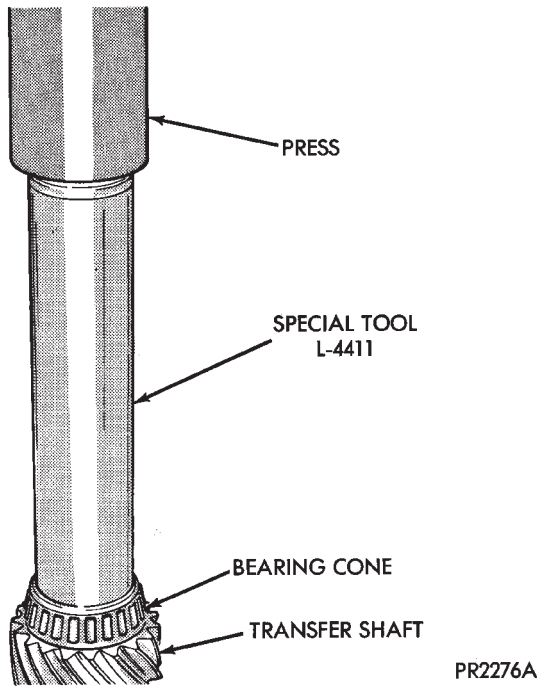

PR2276A

Fig. 19 Install Transfer Shaft Bearing Cone

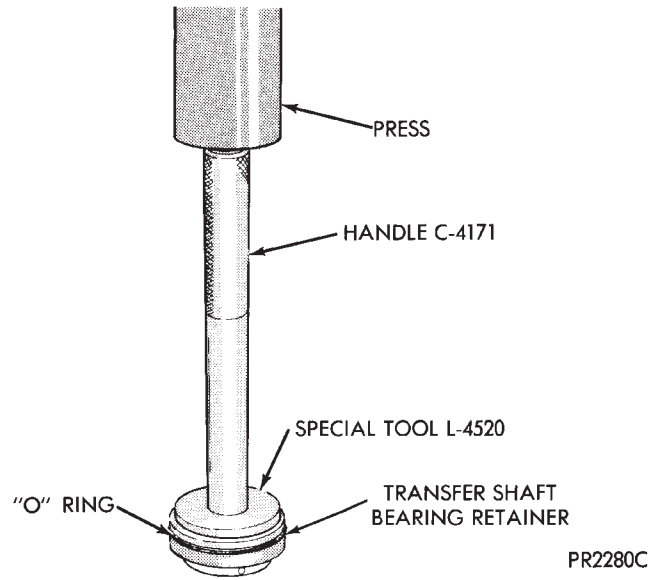

PR2280C

Fig. 21 Install Transfer Shaft Bearing Cup



DETERMINING SHIM THICKNESS

Shim thickness need only be determined if any of the following parts are replaced: (a) transaxle case, (b) transfer shaft, (c) transfer shaft gear, (d) transfer shaft bearings, (e) governor support retainer, (f) transfer shaft bearing retainer, (g) retainer snap ring, or (h) governor support. Refer to "Bearing Adjustment Procedure" in rear of this section to determine proper shim thickness for correct end play.

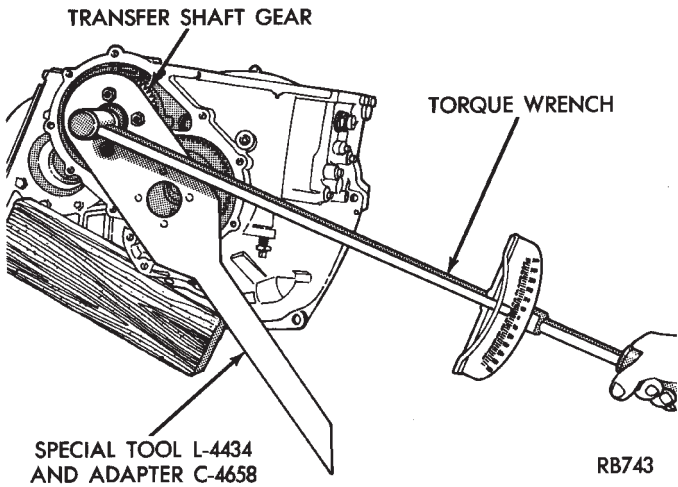

Fig. 22 Tighten Transfer Shaft Gear Retaining Nut to 271 Nm (200 ft. lbs.)

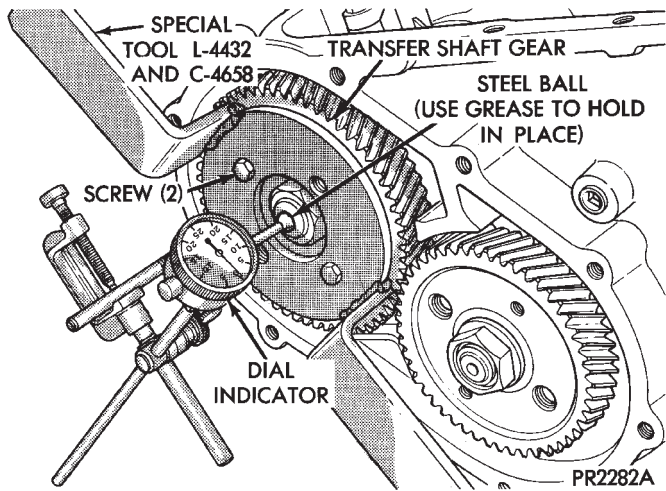

Fig. 23 Checking Transfer Shaft End Play

PARKING PAWL

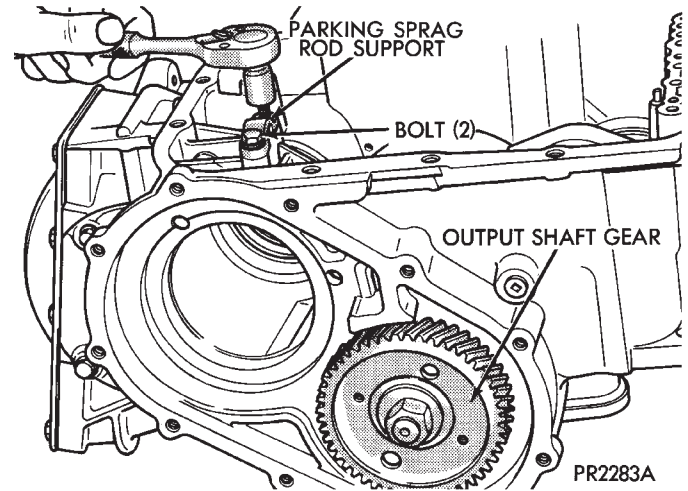

Fig. 24 Parking Sprag Rod Support Bolts

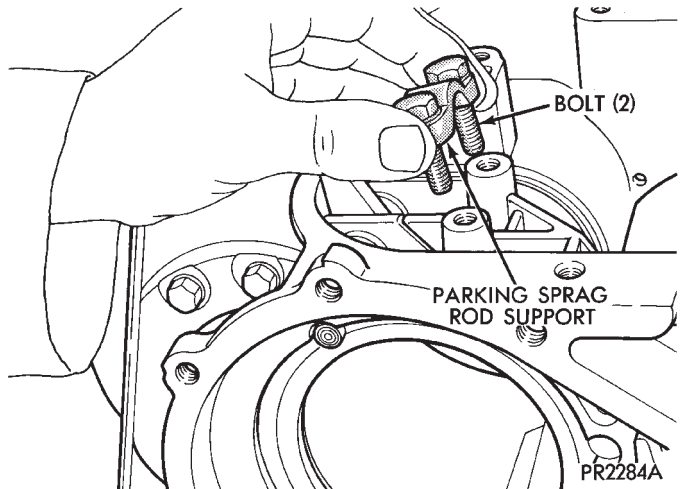

Fig. 25 Support and Bolts

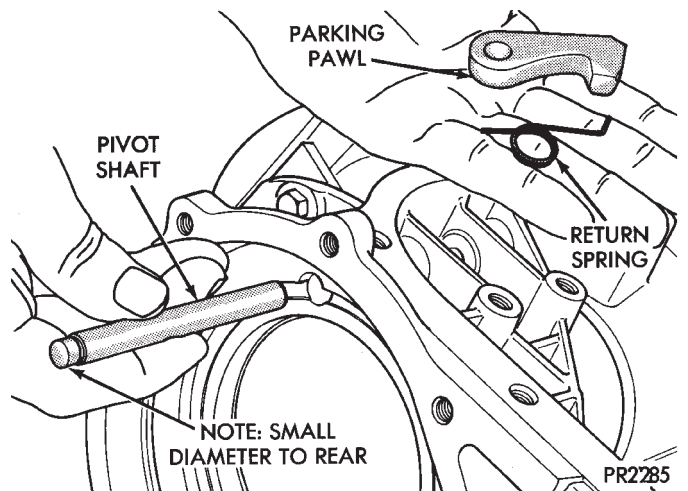

Fig. 26 Parking Pawl, Return Spring, and Pivot Shaft
To install, reverse the above procedure.



OUTPUT SHAFT REPAIR

Transfer shaft should be removed for repair of output shaft. Planetary gear sets must be removed to accurately check output shaft bearing turning torque.

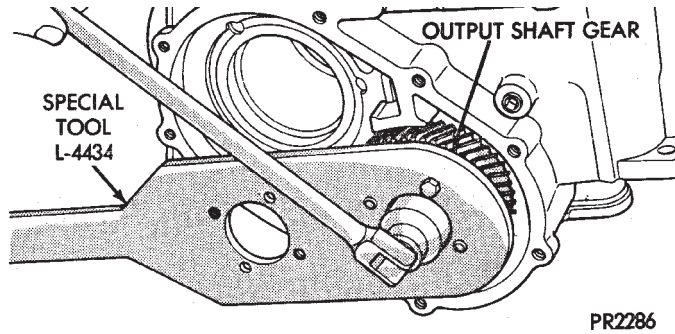

Fig. 1 Remove Output Shaft Retaining Nut and Washer

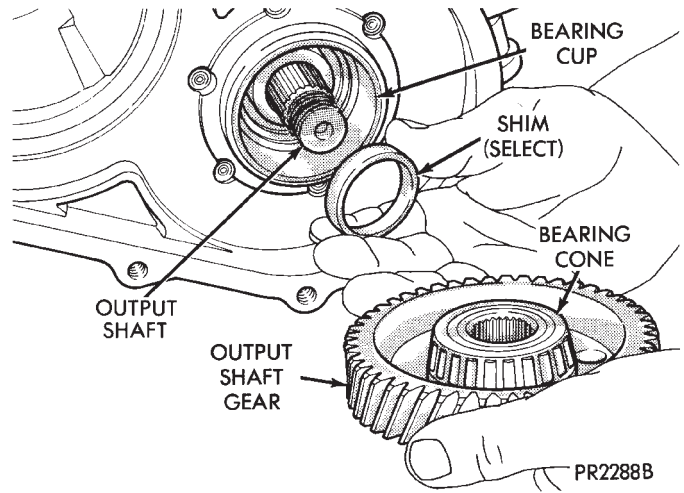

Fig. 3 Output Shaft Gear and (Select) Shim

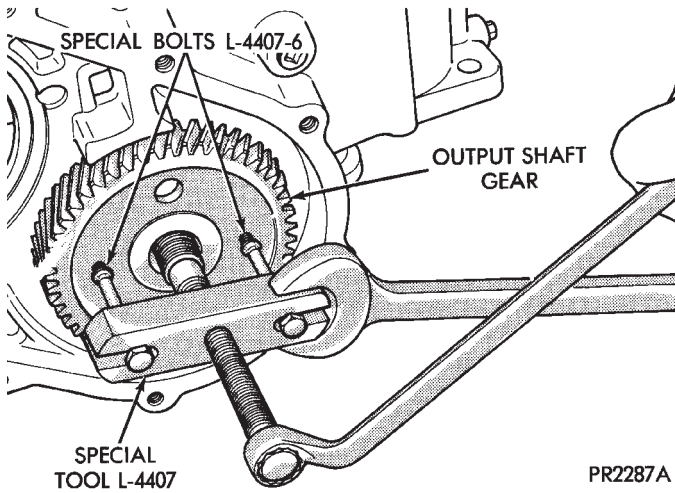

Fig. 2 Remove Output Shaft Gear

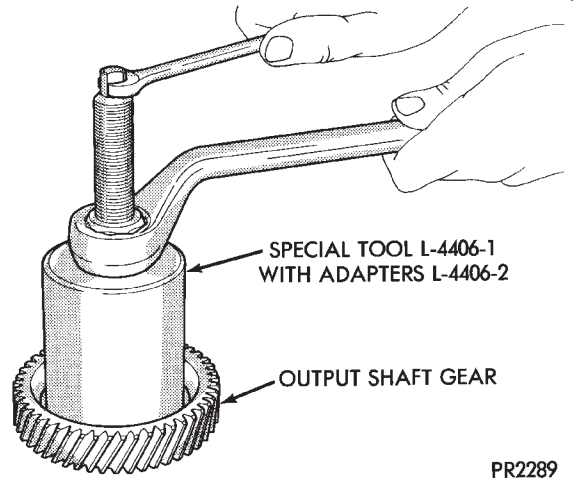

Fig. 4 Remove Output Shaft Gear Bearing Cone

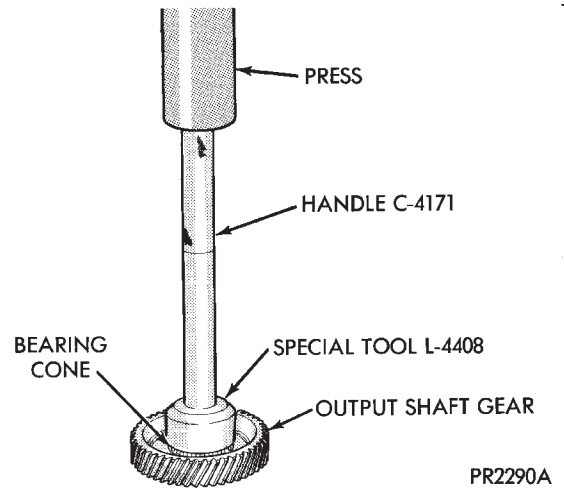

Fig. 5 Install Output Shaft Gear Bearing Cone

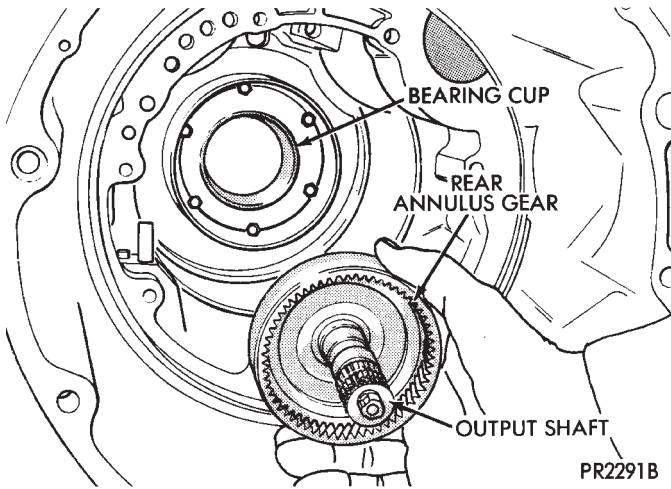

Fig. 6 Remove Output Shaft and Rear Annulus Gear Assembly

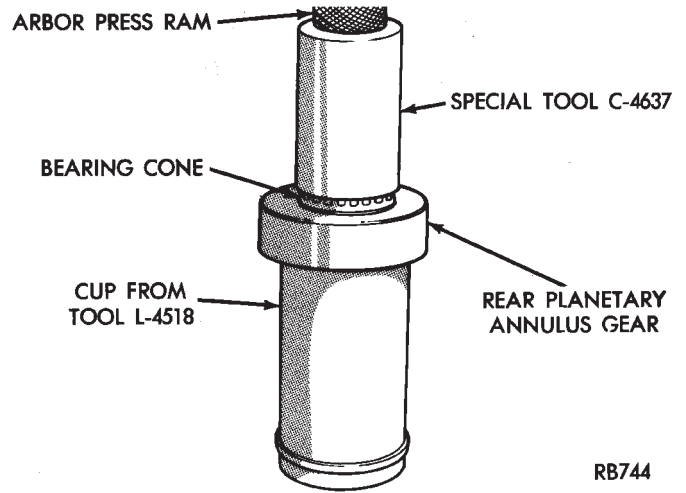

Fig. 9 Install Rear Planetary Annulus Gear Bearing Cone

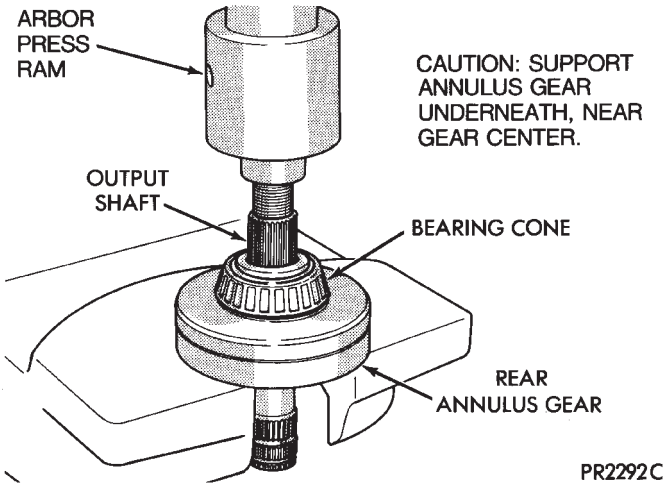

Fig. 7 Remove Output Shaft

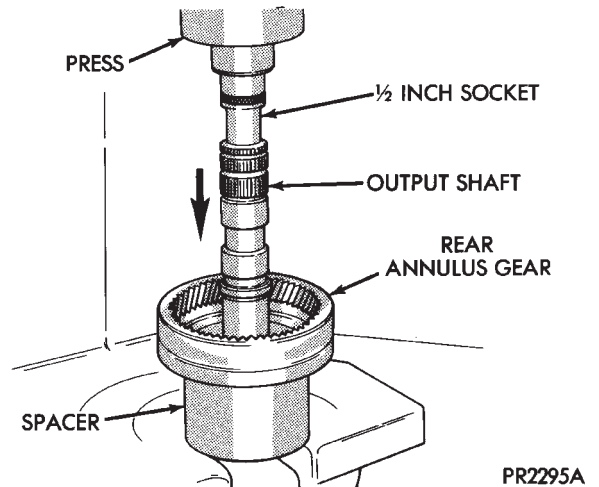

Fig. 10 Install Output Shaft into Rear Planetary Annulus Gear

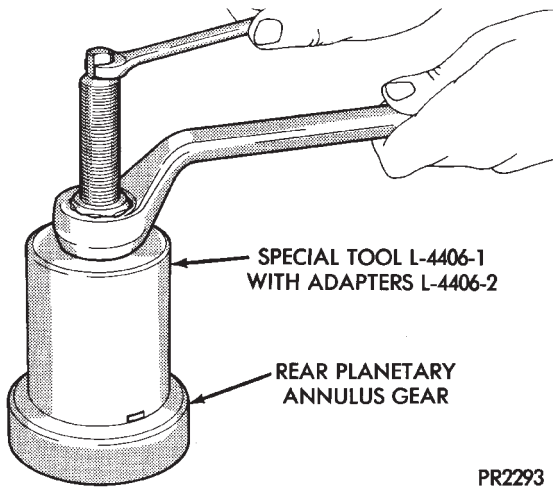

Fig. 8 Remove Rear Planetary Annulus Gear Bearing Cone

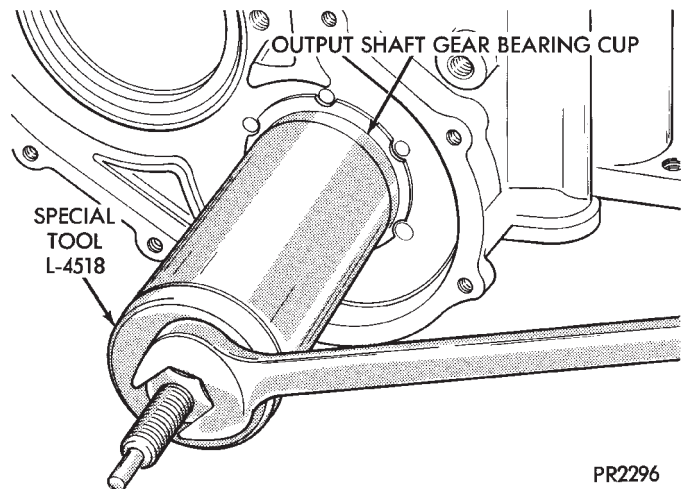

Fig. 11 Remove Output Shaft Gear Bearing Cup

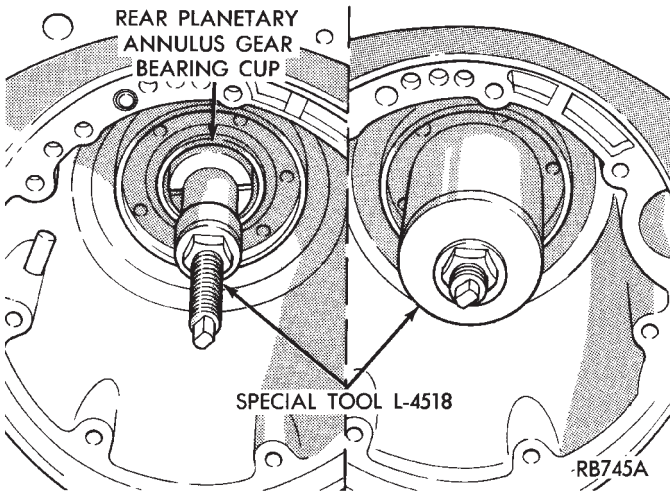

Fig. 12 Remove Rear Planetary Annulus Gear Bearing Cup

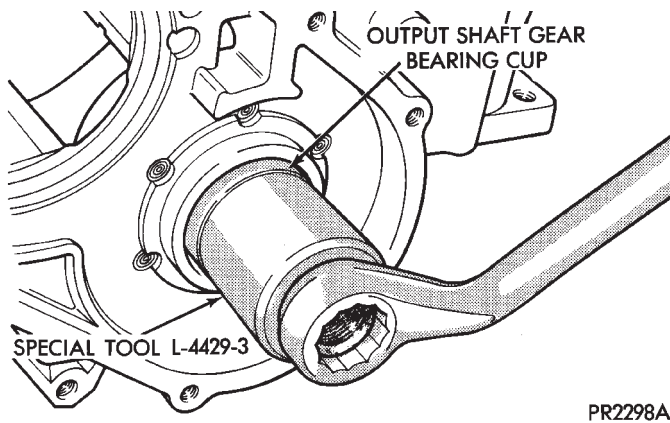

Fig. 13 Install Output Shaft Gear Bearing Cup

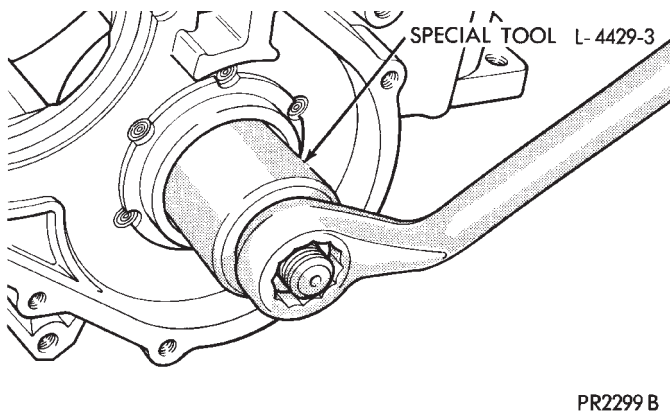

Fig. 14 Install Rear Planetary Annulus Gear Bearing Cup

DETERMINING SHIM THICKNESS

Shim thickness need only be determined if any of the following parts are replaced:

- Transaxle case
- Output shaft
- Rear planetary annulus gear
- Output shaft gear
- Rear annulus and output shaft gear bearing cones
- Overrunning clutch race cups

Refer to "Bearing Adjustment Procedure" at the rear of this section, to determine proper shim thickness for correct bearing preload and turning torque. **Check output shaft bearings turning torque, using an inch-pound torque wrench. If turning torque is 3 to 8 inch-pounds, the proper shim has been installed.**

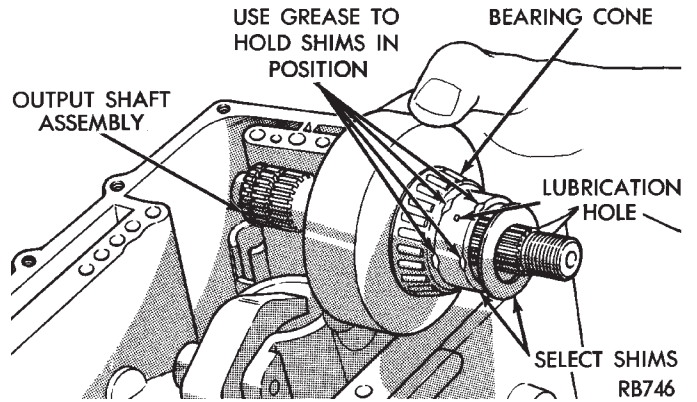

Fig. 15 Install Output Shaft Assembly

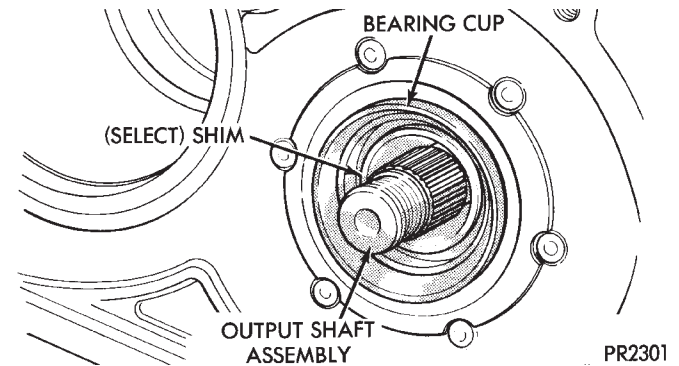

Fig. 16 Output Shaft and (Select) Shims in Position

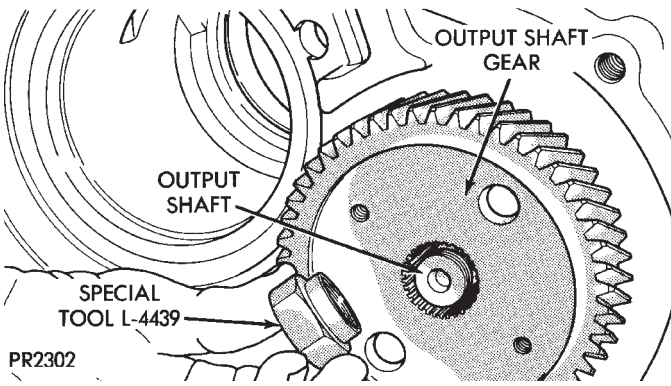

Fig. 17 Start Output Shaft Gear onto Output Shaft

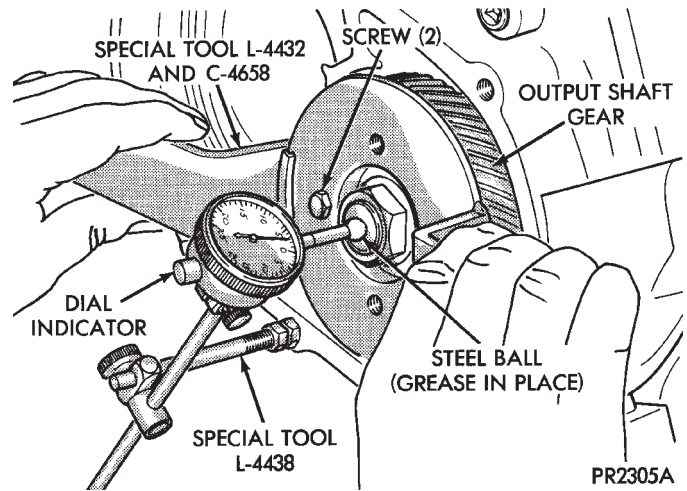

Fig. 20 Checking Output Shaft End Play

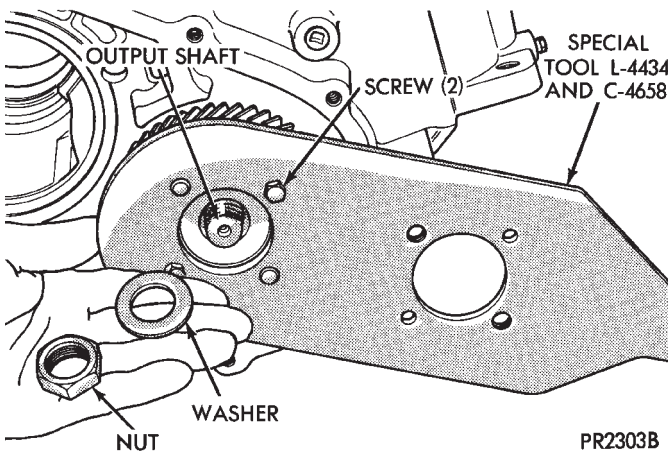

Fig. 18 Holding Output Shaft Gear

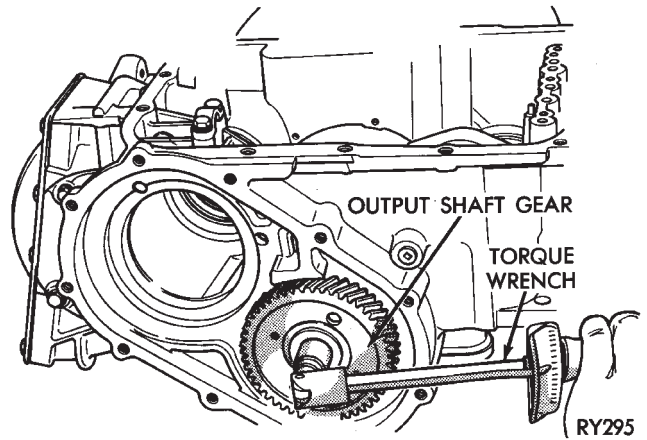

Fig. 21 Checking Bearings Turning Torque

DIFFERENTIAL REPAIR

The transfer shaft should be removed for differential repair and bearing turning torque checking.

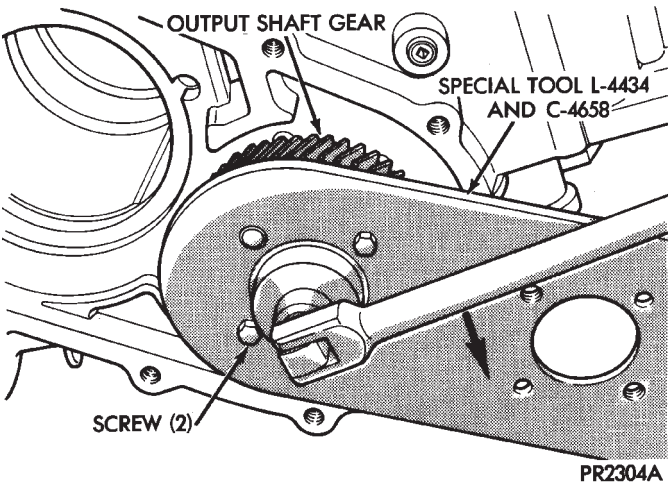

Fig. 19 Tighten Output Shaft Retaining Nut to 271 N_om (200 ft. lbs.)

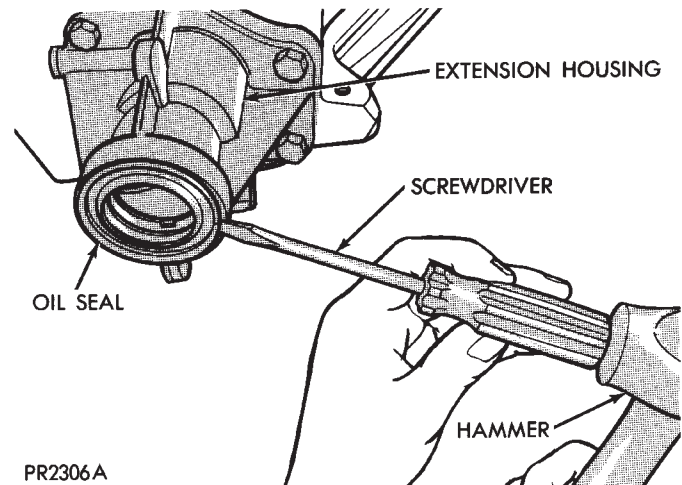

Fig. 1 Remove Extension Seal

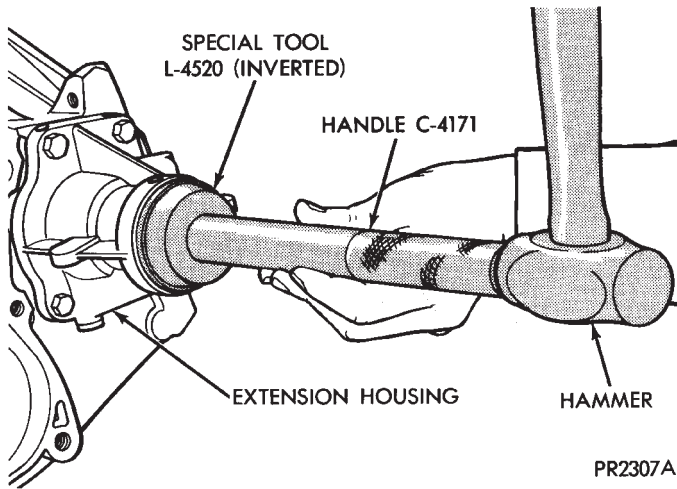

Fig. 2 Install New Seal into Extension

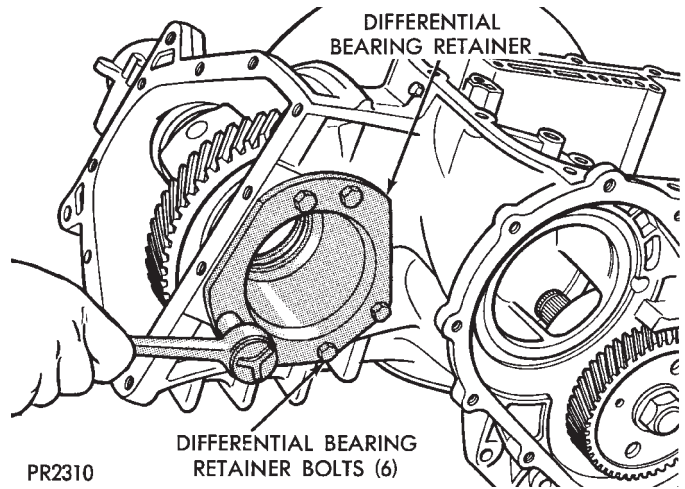

Fig. 5 Differential Bearing Retainer Bolts

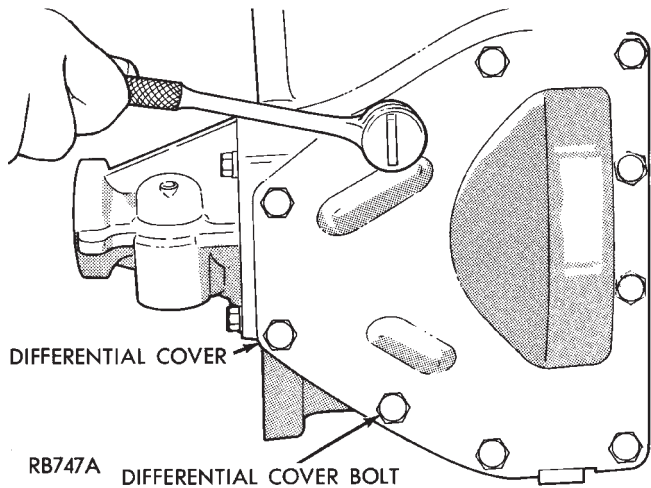

Fig. 3 Differential Cover Bolts

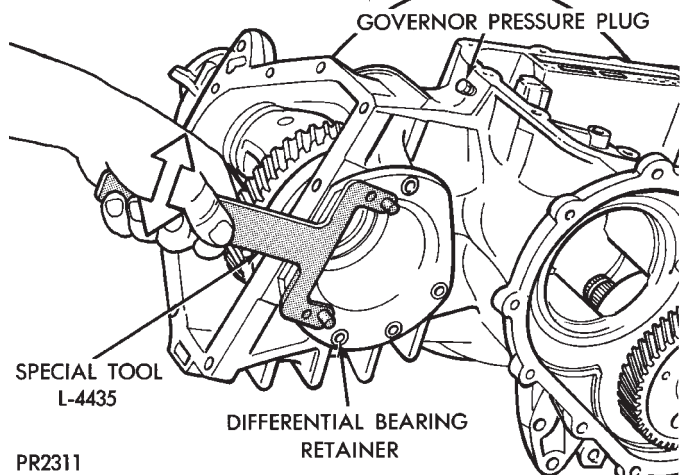

Fig. 6 Remove or Install Bearing Retainer

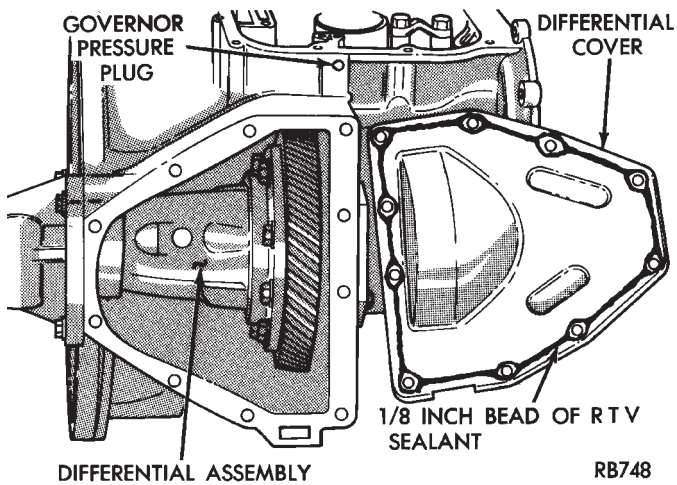

Fig. 4 Remove or Install Differential Cover

**Use Mopar® Silicone Rubber Adhesive Sealant or equivalent when installing differential cover.
Use Mopar® Silicone Rubber Adhesive Sealant or equivalent when installing differential bear-**

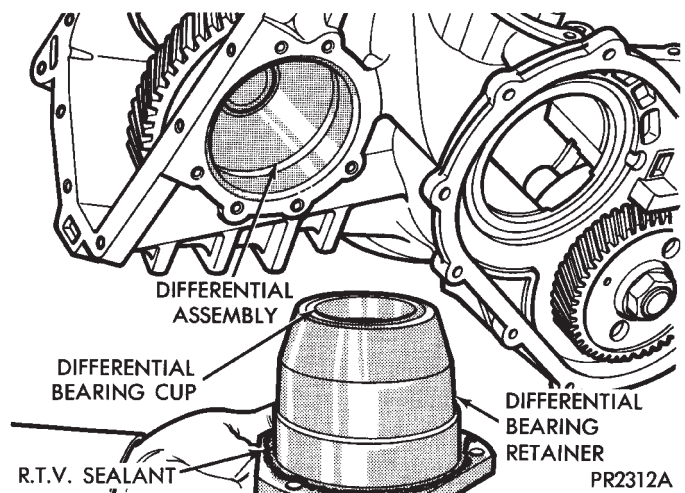

Fig. 7 Differential Bearing Retainer (Typical) ing retainer.

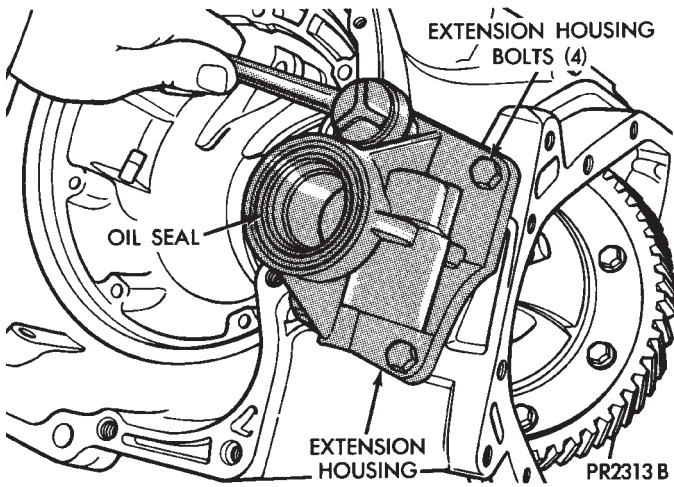

Fig. 8 Extension Bolts

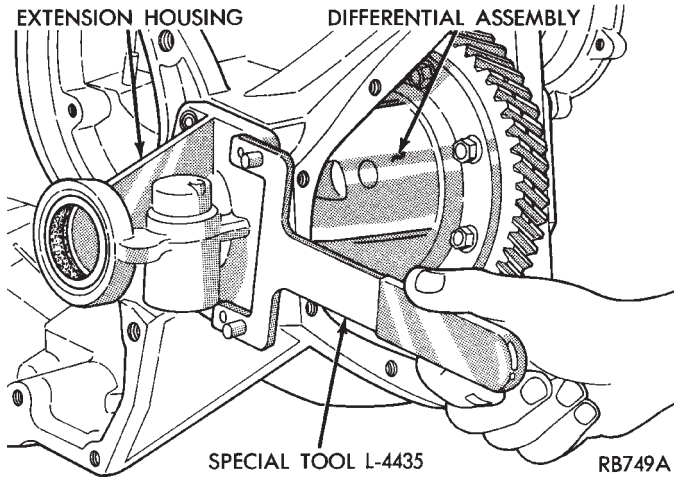

Fig. 9 Remove or Install Extension Housing

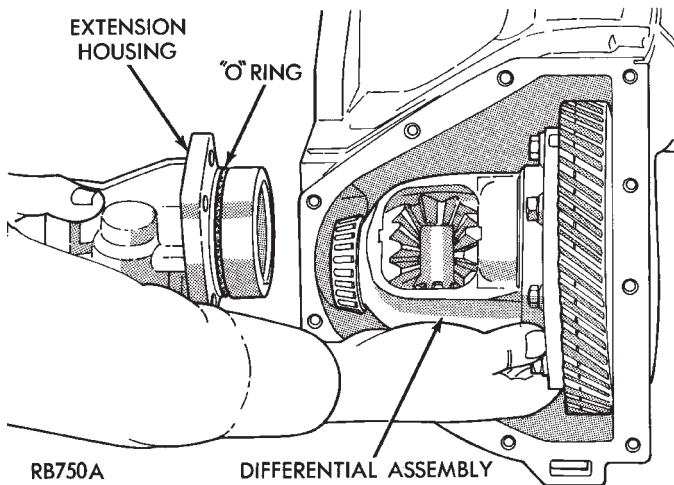

Fig. 10 Differential and Extension

WARNING: HOLD ONTO DIFFERENTIAL ASSEMBLY TO PREVENT IT FROM ROLLING OUT OF HOUSING.

Use Mopar® Silicone Rubber Adhesive Sealant or equivalent when installing extension housing.

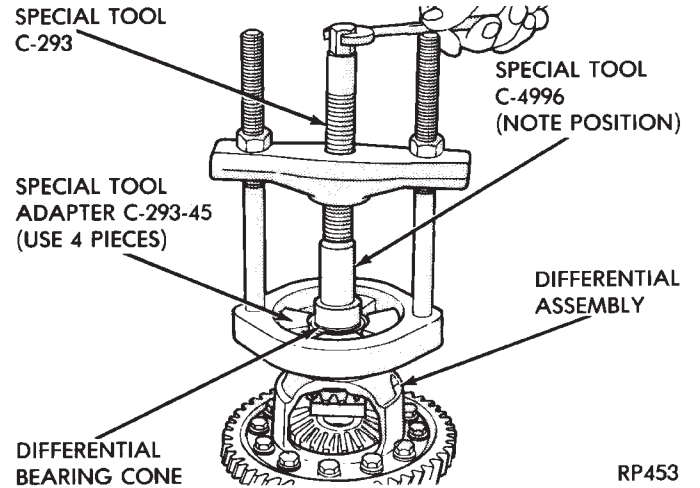

Fig. 11 Remove Differential Bearing Cone

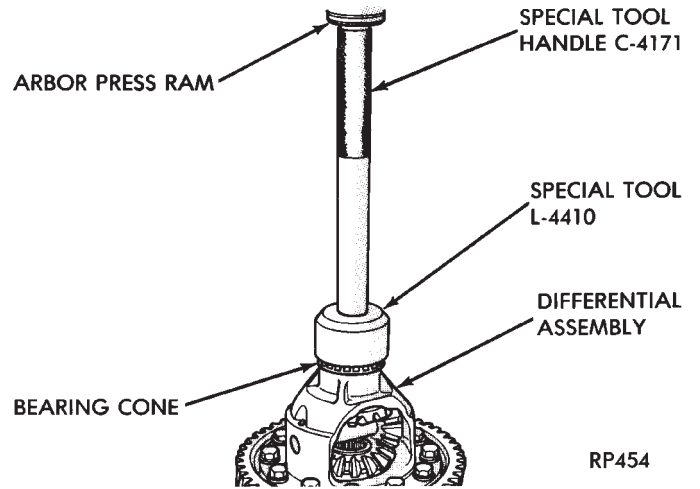
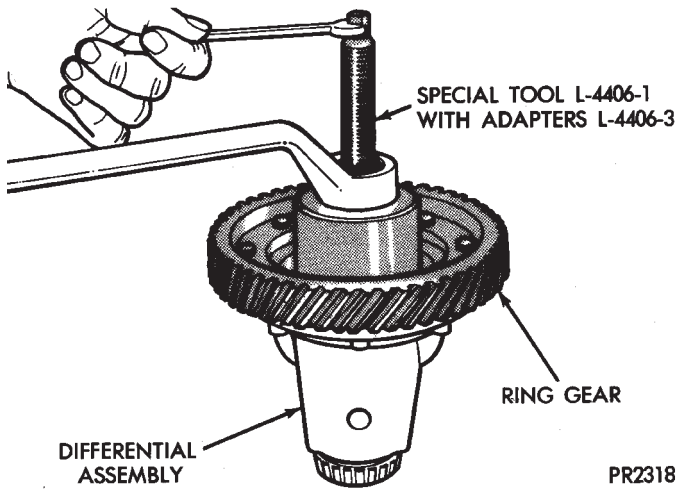
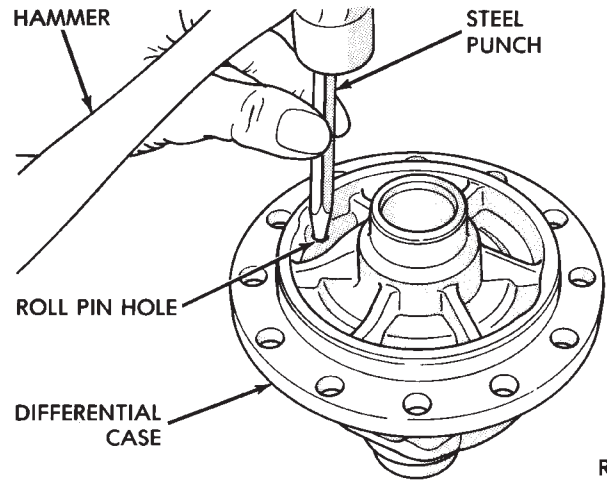

Fig. 12 Install Differential Bearing Cone



PR2318

Fig. 13 Remove Differential Bearing Cone



RP458

Fig. 16 Remove Pinion Shaft Roll Pin

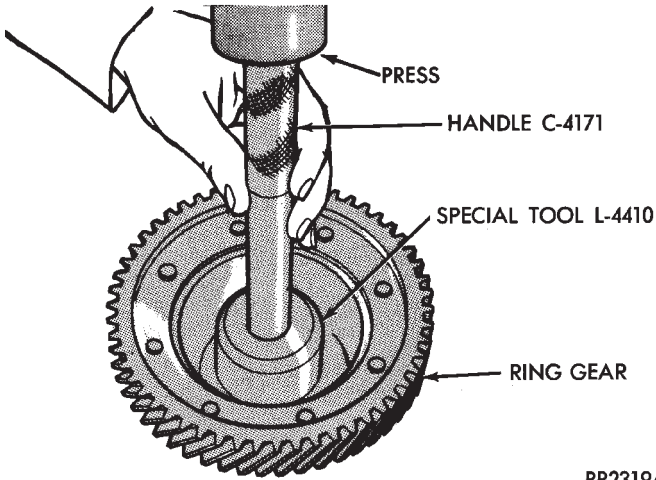

PR2319A

Fig. 14 Install Differential Bearing Cone

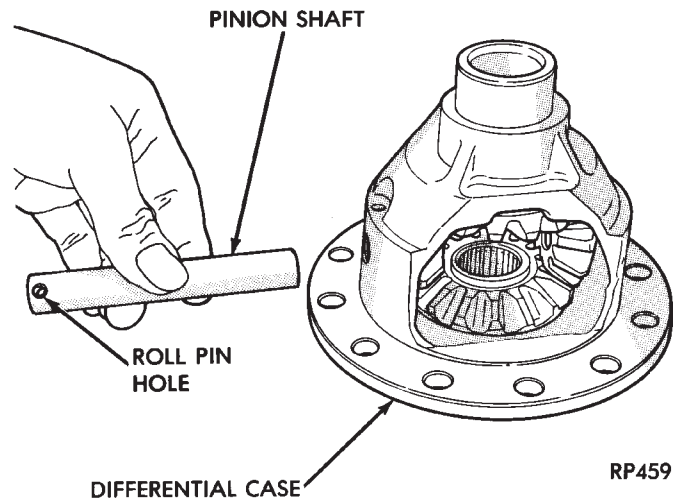

RP459

Fig. 17 Remove or Install Pinion Shaft

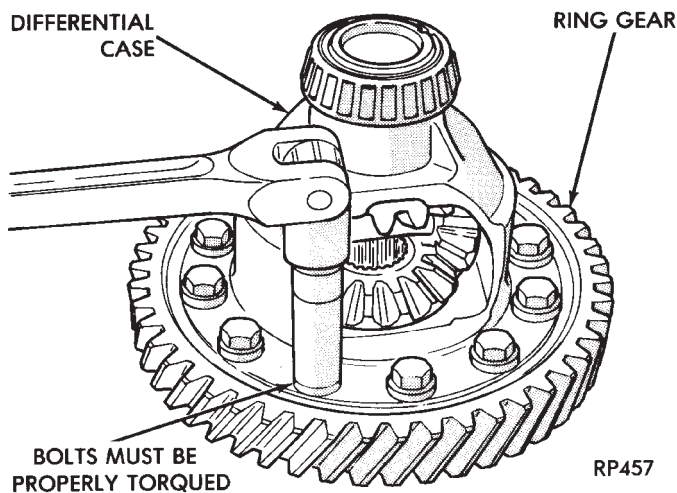

RP457

Fig. 15 Remove or Install Ring Gear Bolts and Ring Gear

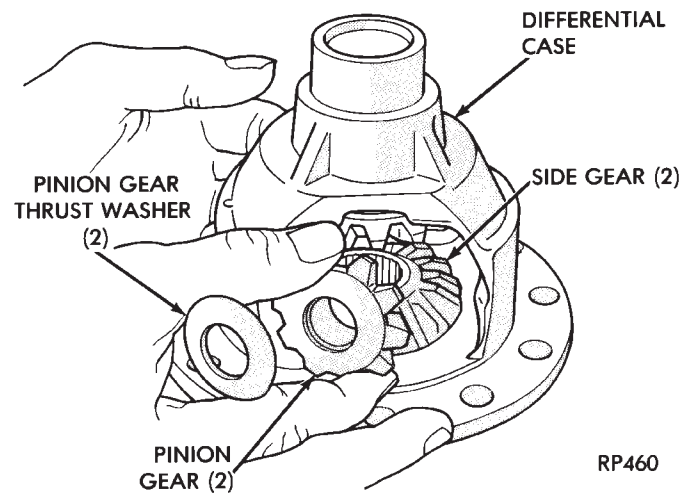

RP460

Fig. 18 Remove or Install Pinion Gears, Side Gears, and Tabbed Thrust Washers, by Rotating Pinion Gears to Opening in Differential Case

CAUTION: Always install new ring gear bolts. Bolts must be properly torqued.

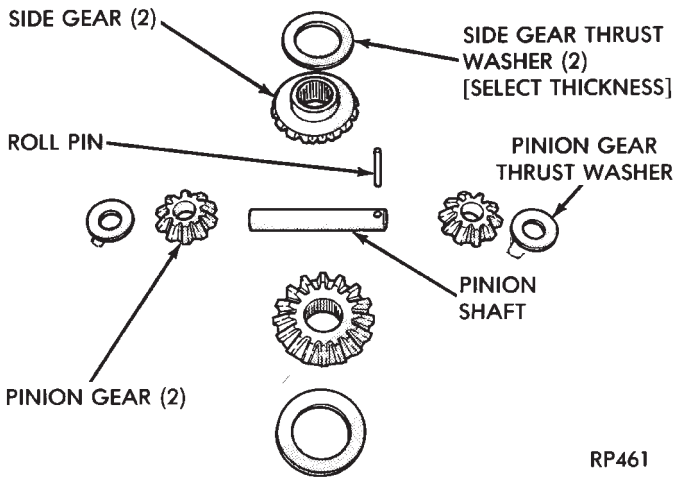

RP461

Fig. 19 Differential Gears

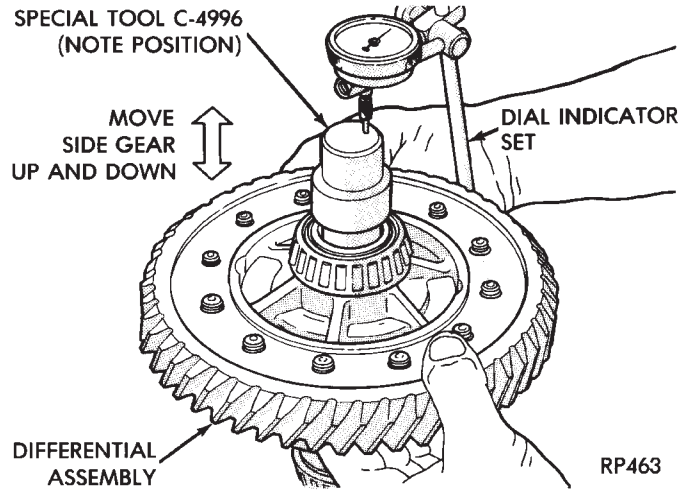

RP463

Fig. 21 Checking Side Gear End Play

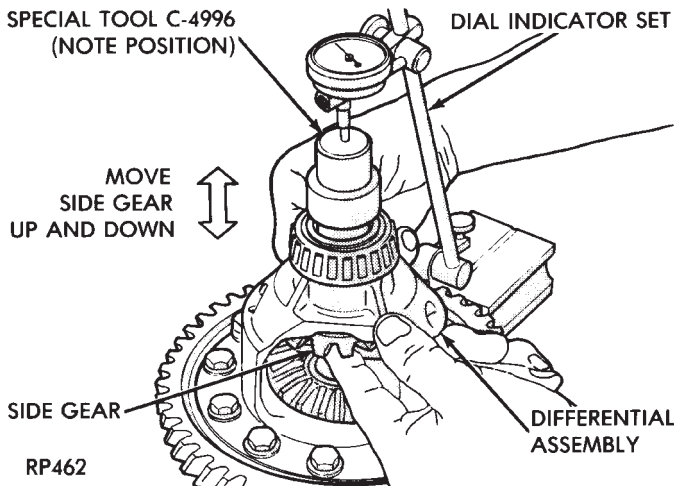

RP462

Fig. 20 Checking Side Gear End Play

CAUTION: Side gear end play must be within .001 to .013 inch.

Four select thrust washers are available: .032, .037, .042, and .047 inch.

DETERMINING SHIM THICKNESS

Shim thickness need only be determined if any of the following parts are replaced:

- Transaxle case
- Differential carrier
- Differential bearing retainer
- Extension housing
- Differential bearing cups and cones

Refer to "Bearing Adjustment Procedure" in rear of this section to determine proper shim thickness for correct bearing preload and proper bearing turning torque.

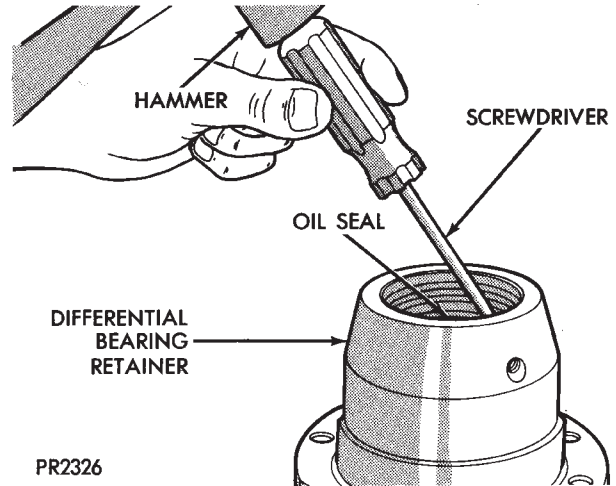

PR2326

Fig. 22 Remove Oil Seal

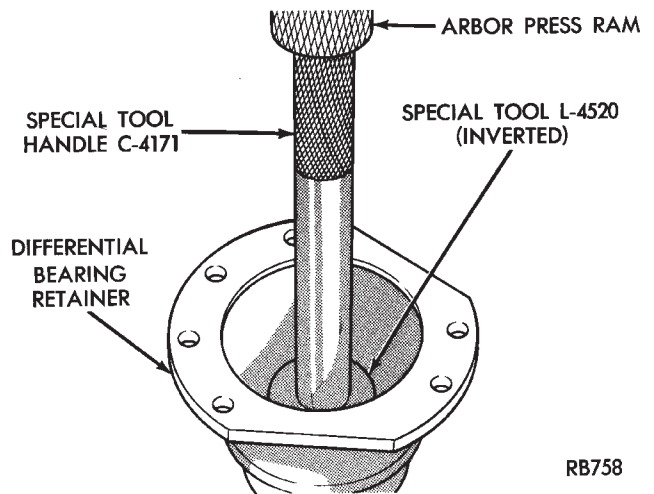

RB758

Fig. 23 Install New Oil Seal

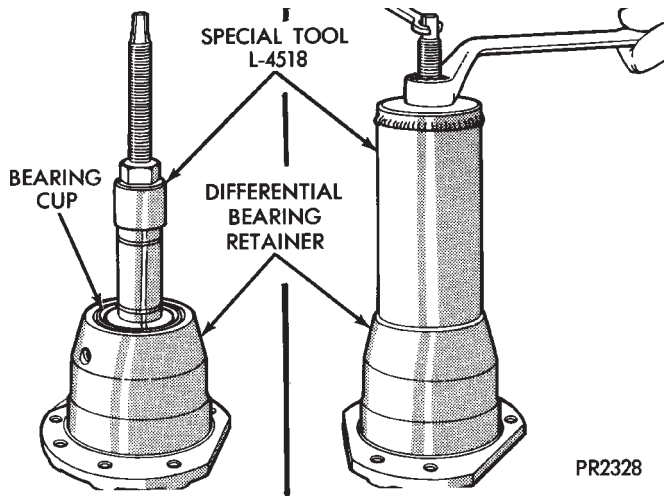

Fig. 24 Remove Bearing Cup

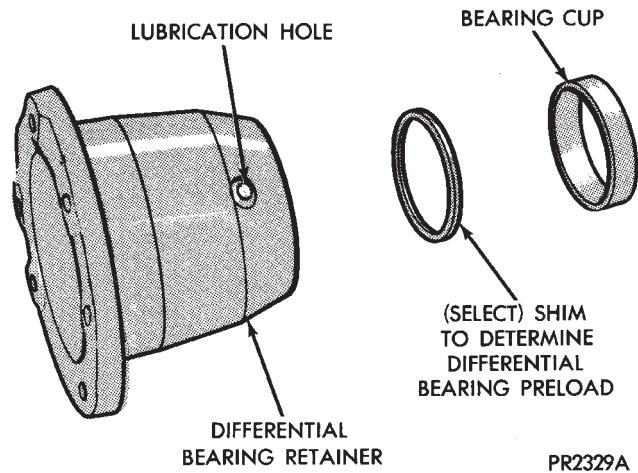

Fig. 25 Differential Bearing Retainer

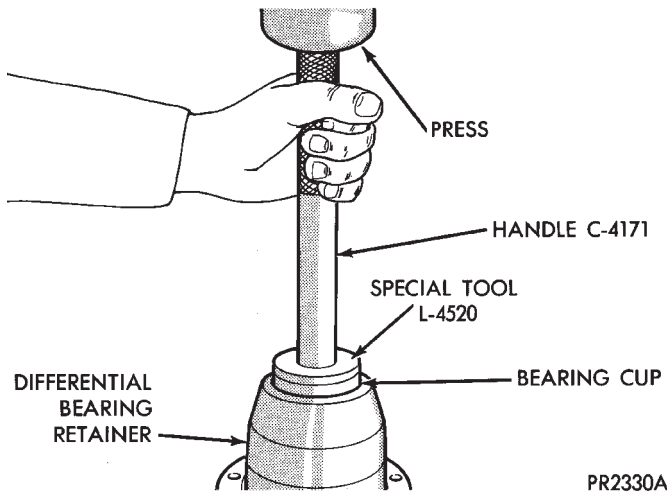

Fig. 26 Install Bearing Cup

When rebuilding, reverse the above procedure. Remove old before applying new sealant. Use Mopar® Silicone Rubber Adhesive Sealant or equivalent on retainer to seal retainer to case.

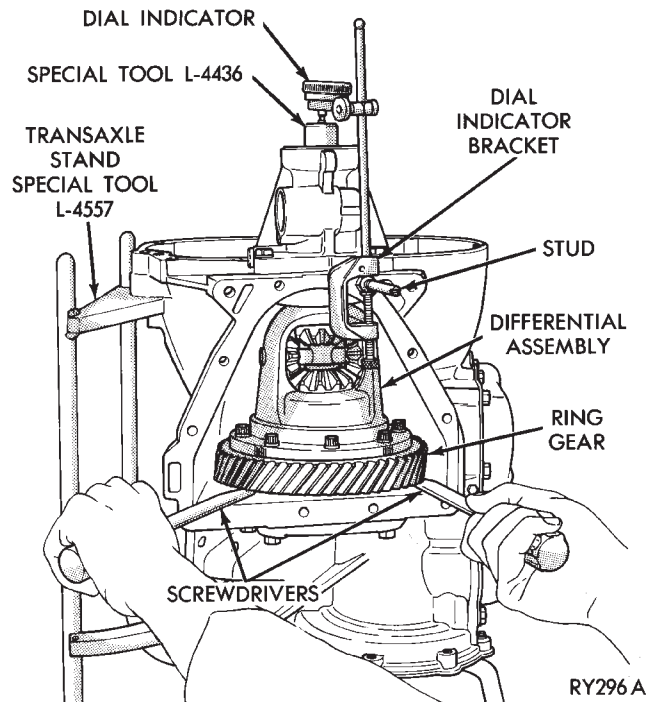

Fig. 27 Checking Differential End Play

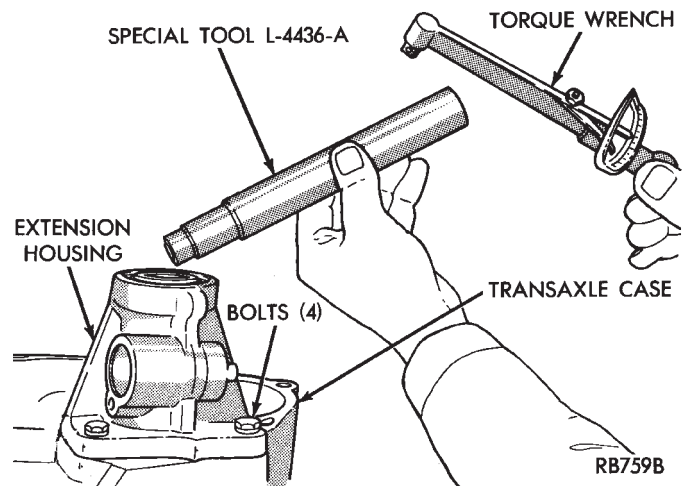

Fig. 28 Tool L-4436 and Torque Wrench

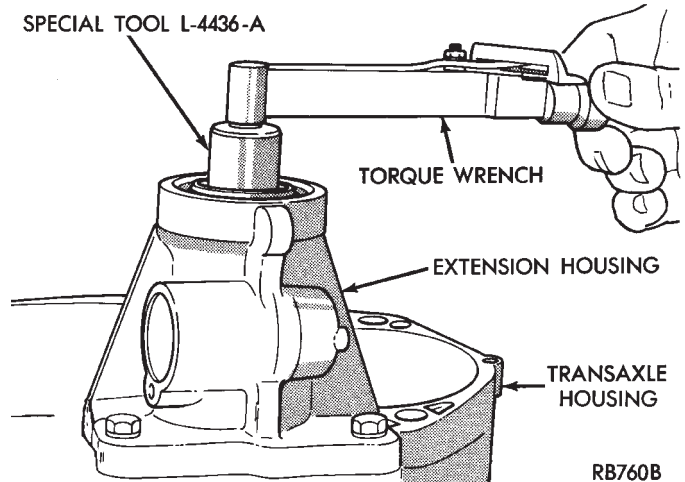

Fig. 29 Checking Differential Bearings Turning Torque

BEARING ADJUSTMENT PROCEDURES

GENERAL RULES ON SERVICING BEARINGS

(1) Take extreme care when removing and installing bearing cups and cones. **Use only an arbor press for installation**, as a hammer may not properly align the bearing cup or cone. Burrs or nicks on the bearing seat will give a false end play reading, while gauging for proper shims. Improperly seated bearing cup and cones are subject to low-mileage failure.

(2) Bearing cups and cones should be replaced if they show signs of pitting or heat distress.

If distress is seen on either the cup or bearing rollers, both cup and cone must be replaced.

Bearing end play and drag torque specifications must be maintained to avoid premature bearing failures.

Used (original) bearing may lose up to 50 of the original drag torque after break-in.

All bearing adjustments must be made with no other component interference or gear intermesh, except the transfer gear bearing.

OUTPUT SHAFT BEARING

With output shaft gear removed.

(1) Install a 13.65 mm (.537 inch) and a 1.34 mm (.053 inch) gauging shims on the planetary rear annulus gear hub using grease to hold the shims in place. The 13.65 mm shim has a larger inside diameter and must be installed over the output shaft first. The 1.34 mm shim pilots on the output shaft.

(2) Install output shaft gear and bearing assembly, torque to 271 N•m (200 ft. lbs.).

(3) To measure bearing end play:

(a) Attach Tool L-4432 to the output shaft gear.

(b) Mount a steel ball with grease into the end of the output shaft.

(c) Push and pull the gear while rotating back and forth to insure seating of the bearing rollers.

(d) Using a dial indicator, mounted to the transaxle case, measure output shaft end play.

(4) Once bearing end play has been determined, refer to the output shaft bearing shim chart for the required shim combination to obtain proper bearing setting.

(a) The 12.65 mm (.498 inch), 13.15 mm (.518 inch) or 13.65 mm (.537 inch) shims are always installed first. **These shims have lubrication slots which are necessary for proper bearing lubrication.**

(b) Shims thinner than 12.65 mm listed in the chart are common to both the transfer shaft and output shaft bearings.

(5) Use Tool L-4434 to remove the retaining nut and washer. To remove the output shaft gear use Tool L-4407.

(6) Remove the two gauging shims and install the proper shim combination, making sure to install the

12.65, 13.15, or 13.65 mm shim first. Use grease to hold the shims in place. Install the output shaft gear and bearing assembly.

(7) Install the retaining nut and washer and torque to 271 N•m (200 ft. lbs.).

(8) Using an inch-pound torque wrench, check the turning torque. **The torque should be between 3 and 8 inch-pounds.**

If the turning torque is too high, install a .05mm (.002 inch) thicker shim. If the turning torque is too low, install a .05 mm (.002 inch) thinner shim. Repeat until the proper turning torque is 3 to 8 inch pounds.

OUTPUT SHAFT BEARING SHIM CHART

End Play (with 13.65 mm and 1.34 mm gauging shims installed)		Required Shim Combination	Total Thickness	
mm	inch		mm	inch
.0	.0	13.65 + 1.34	14.99	.590
.05	.002	13.65 + 1.24	14.89	.586
.10	.004	13.65 + 1.19	14.84	.584
.15	.006	13.65 + 1.14	14.79	.582
.20	.008	13.65 + 1.09	14.74	.580
.25	.010	13.65 + 1.04	14.69	.578
.30	.012	13.65 + .99	14.64	.576
.35	.014	13.65 + .94	14.59	.574
.40	.016	13.15 + 1.39	14.54	.572
.45	.018	13.15 + 1.34	14.49	.570
.50	.020	13.15 + 1.29	14.44	.568
.55	.022	13.15 + 1.24	14.39	.566
.60	.024	13.15 + 1.19	14.34	.564
.65	.026	13.15 + 1.14	14.29	.562
.70	.028	13.15 + 1.09	14.24	.560
.75	.030	13.15 + 1.04	14.19	.558
.80	.032	13.15 + .99	14.14	.556
.85	.034	13.15 + .94	14.09	.554
.90	.036	12.65 + 1.39	14.04	.552
.95	.038	12.65 + 1.34	13.99	.550
1.00	.040	12.65 + 1.29	13.94	.548
1.05	.042	12.65 + 1.24	13.89	.547
1.10	.044	12.65 + 1.19	13.84	.545
1.15	.046	12.65 + 1.14	13.79	.543
1.20	.048	12.65 + 1.09	13.74	.541
1.25	.049	12.65 + 1.04	13.69	.539
1.30	.051	12.65 + .99	13.64	.537
1.35	.053	12.65 + .94	13.59	.535

Average Conversion .05 mm = .002 inch

9121-17

DIFFERENTIAL BEARING

(1) Remove the bearing cup from the differential bearing retainer using Tool L-4518, and remove the existing shim from under the cup.

(2) Install a .50 mm (.020 inch) gauging shim and reinstall the bearing cup into the retainer. Use an arbor press to install the cup.

Oil Baffle is not required when making shim selection.

(3) Install the bearing retainer into the case and torque bolts to 28 N•m (250 in. lbs.).

(4) Position the transaxle assembly vertically on the support stand and install Tool L-4436 into the extension.

(5) Rotate the differential at least one full revolution to ensure the tapered roller bearings are fully seated.

(6) Attach a dial indicator to the case and zero the dial indicator. Place the indicator tip on the end of Tool L-4436.

(7) Place a large screwdriver to each side of the ring gear and lift. Check the dial indicator for the amount of end play.

CAUTION: Do not damage the transaxle case and/or differential cover sealing surface.

(8) When the end play has been determined, refer to the Differential Bearing Shim Chart for the correct shim combination to obtain the proper bearing setting.

(9) Remove the differential bearing retainer. Remove the bearing cup and the .50 mm (.020 inch) gauging shim.

DIFFERENTIAL BEARING SHIM CHART

End Play (with .50 mm gauging shim installed)		Required Shim Combination	Total Thickness	
mm	inch		mm	inch
.0	.0	.50	.50	.020
.05	.002	.75	.75	.030
.10	.004	.80	.80	.032
.15	.006	.85	.85	.034
.20	.008	.90	.90	.035
.25	.010	.95	.95	.037
.30	.012	1.00	1.00	.039
.35	.014	1.05	1.05	.041
.40	.016	.50 + .60	1.10	.043
.45	.018	.50 + .65	1.15	.045
.50	.020	.50 + .70	1.20	.047
.55	.022	.50 + .75	1.25	.049
.60	.024	.50 + .80	1.30	.051
.65	.026	.50 + .85	1.35	.053
.70	.027	.50 + .90	1.40	.055
.75	.029	.50 + .95	1.45	.057
.80	.031	.50 + 1.00	1.50	.059
.85	.033	.50 + 1.05	1.55	.061
.90	.035	1.00 + .60	1.60	.063
.95	.037	1.00 + .65	1.65	.065
1.00	.039	1.00 + .70	1.70	.067
1.05	.041	1.00 + .75	1.75	.069
1.10	.043	1.00 + .80	1.80	.071
1.15	.045	1.00 + .85	1.85	.073
1.20	.047	1.00 + .90	1.90	.075
1.25	.049	1.00 + .95	1.95	.077
1.30	.051	1.00 + 1.00	2.00	.079
1.35	.053	1.00 + 1.05	2.05	.081
1.40	.055	1.05 + 1.05	2.10	.083

(10) Install the proper shim combination under the bearing cup. Make sure the oil baffle is installed properly in the bearing retainer, below the bearing shim and cup.

(11) Install the differential bearing retainer. Seal the retainer to the housing with Mopar® Silicone Rubber Adhesive Sealant or equivalent and torque bolts to 28 N•m (250 in. lbs.).

(12) Using special Tool L-4436 and an inch-pound torque wrench, check the turning torque of the differential. **The turning torque should be between 5 and 18 inch-pounds.**

If the turning torque is too high, install a .05 mm (.002 inch) thinner shim. If the turning torque is too low, install a .05 mm (.002 inch) thicker shim. Repeat until 5 to 18 inch-pounds turning torque is obtained.

TRANSFER SHAFT BEARING

(1) Use Tool L-4434 to remove the retaining nut and washer. Remove the transfer shaft gear using Tool L-4407.

(2) Install a 2.29 mm (.090 inch) and a 1.39 mm (.055 inch) gauging shims on the transfer shaft behind the governor support.

(3) Install transfer shaft gear and bearing assembly and torque the nut to 271 N•m (200 ft. lbs.).

(4) To measure bearing end play:

(a) Attach Tool L-4432 to the transfer gear.

(b) Mount a steel ball with grease into the end of the transfer shaft.

(c) Push and pull the gear while rotating back and forth to insure seating of the bearing rollers.

(d) Using a dial indicator, measure transfer shaft end play.

(5) Refer to the Transfer Bearing Shim Chart for the required shim combination to obtain the proper bearing setting.

(6) Use Tool L-4434 to remove the retaining nut and washer. Remove the transfer shaft gear using Tool L-4407.

(7) Remove the two gauging shims and install the correct shim combination. Install the transfer gear and bearing assembly.

(8) Install the retaining nut and washer and torque to 271 N•m (200 ft. lbs.). Measure transfer shaft end play, end play should be .05 to .25 mm (.002 to .010 inch).

(9) Measure bearing end play as outlined in Step (4). End play should be between .05 mm and .25 mm (.002 to .010 inch).

TRANSFER BEARING SHIM CHART

End Play (with 2.29 mm and 1.39 mm gauging shims installed)		Required Shim Combination	Total Thickness	
mm	inch		mm	inch
.0	.0	2.29 + 1.39	3.68	.145
.05	.002	2.29 + 1.39	3.68	.145
.10	.004	2.29 + 1.39	3.68	.145
.15	.006	2.29 + 1.39	3.68	.145
.20	.008	2.29 + 1.34	3.63	.143
.25	.010	2.29 + 1.29	3.58	.141
.30	.012	2.29 + 1.24	3.53	.139
.35	.014	2.29 + 1.19	3.48	.137
.40	.016	2.29 + 1.14	3.43	.135
.45	.018	2.29 + 1.09	3.38	.133
.50	.020	2.29 + 1.04	3.33	.131
.55	.022	2.29 + .99	3.28	.129
.60	.024	1.84 + 1.39	3.23	.127
.65	.026	1.84 + 1.34	3.18	.125
.70	.028	1.84 + 1.29	3.13	.123
.75	.030	1.84 + 1.24	3.08	.121
.80	.032	1.84 + 1.19	3.03	.119
.85	.034	1.84 + 1.14	2.98	.117
.90	.036	1.84 + 1.09	2.93	.115
.95	.038	1.84 + 1.04	2.88	.113
1.00	.040	1.84 + .99	2.83	.111
1.05	.042	1.39 + 1.39	2.78	.109
1.10	.044	1.39 + 1.34	2.73	.107
1.15	.046	1.39 + 1.29	2.68	.105
1.20	.048	1.39 + 1.24	2.63	.103
1.25	.049	1.39 + 1.19	2.58	.101
1.30	.050	1.39 + 1.14	2.53	.099
1.35	.052	1.39 + 1.09	2.48	.097
1.40	.055	1.39 + 1.04	2.43	.095
1.45	.057	1.39 + .99	2.38	.093
1.50	.059	.94 + 1.39	2.33	.091
1.55	.061	.94 + 1.34	2.28	.089
1.60	.063	.94 + 1.29	2.23	.087

9121-15

If end play is too high, install a .05 mm (.002 inch) thinner shim combination. If end play is too low, install a .05 mm (.002 inch) thicker shim combination. Repeat until .05 to .25 mm (.002 to .010 inch) end play is obtained.

BEARING SHIM CHART

Shim Thickness		Bearing Usage		
mm	inch	Output Shaft	Transfer Shaft	Differ- ential
0.94	.037	X	X	—
0.99	.039	X	X	—
1.04	.041	X	X	—
1.09	.043	X	X	—
1.14	.045	X	X	—
1.19	.047	X	X	—
1.24	.049	X	X	—
1.29	.051	X	X	—
1.34	.053	X*	X	—
1.39	.055	X	X*	—
1.84	.072	X	X	—
2.29	.090	X	X*	—
12.65	.498	X	—	—
13.15	.518	X	—	—
13.65	.537	X*	—	—
0.50	.020	—	—	X*
0.55	.022	—	—	X
0.60	.024	—	—	X
0.65	.026	—	—	X
0.70	.027	—	—	X
0.75	.029	—	—	X
0.80	.031	—	—	X
0.85	.033	—	—	X
0.90	.035	—	—	X
0.95	.037	—	—	X
1.00	.039	—	—	X
1.05	.041	—	—	X

* Also used as gauging shims

9121-14

4-SPEED ELECTRONIC AUTOMATIC TRANSAXLE

INDEX

page	page		
Aluminum Thread Repair	95	Input Clutches-Recondition	116
Bearing Adjustment Procedures	137	Neutral Safety Switch	99
Clutch Air Pressure Tests	92	Oil Cooler Flow Check	95
Determining No. 4 Thrust Plate Thickness (Input Shaft End Play)	115	Oil Coolers and Tubes Reverse Flushing	95
Differential Repair	132	Oil Pump Seal-Replace	132
Distance Sensor Gear	95	PRNDL Switch	99
Fluid and Filter Change	89	Road Test	90
Fluid Drain and Refill	89	Selection of Lubricant	89
Fluid Leakage-Transaxle Torque Converter Housing Area	93	Solenoid Assembly-Replace	98
Fluid Level and Condition	89	Special Additives	89
Gearshift Linkage Adjustment	94	Speed Sensor-Input	99
General Diagnosis	85	Speed Sensor-Output	99
General Information	1	Transaxle Removal and Installation	96
Hydraulic Pressure Tests	91	Transaxle-Recondition	100
		Valve Body-Recondition	128

GENERAL INFORMATION

This electronic four-speed FWD transaxle is the first use of fully-adaptive controls in a production automotive transaxle. Adaptive controls are those which perform their functions based on real-time feedback sensor information, just as is done by electronic anti-lock brake controls. The transaxle is conventional in that it uses hydraulically-applied clutches to shift a planetary gear train, its uses electronics to control virtually all functions.

TRANSAXLE IDENTIFICATION

The transaxle identification code is printed on a label. The label is located on the transaxle case next to the solenoid assembly (Fig. 1).

Refer to Figure 2 for an internal view of the transaxle assembly.

OPERATION

The transaxle provides forward ratios of 2.84, 1.57, 1.00, and 0.69 with torque converter lockup available in 2nd, direct, or overdrive gear; the Reverse ratio is 2.21. The shift lever is conventional with six positions: P, R, N, OD, 3, and L. When OD is selected the transaxle shifts normally through all four speeds with lockup in overdrive; this position is recommended for most driving. The 3 position is tailored for use in hilly or mountainous driving. When 3 is selected, the transmission uses only 1st, 2nd, and direct gears with 2nd-direct shift delayed to 40 mph or greater. When

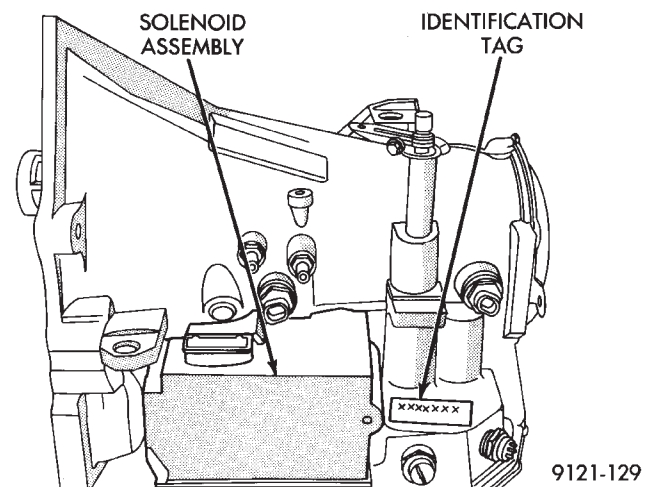
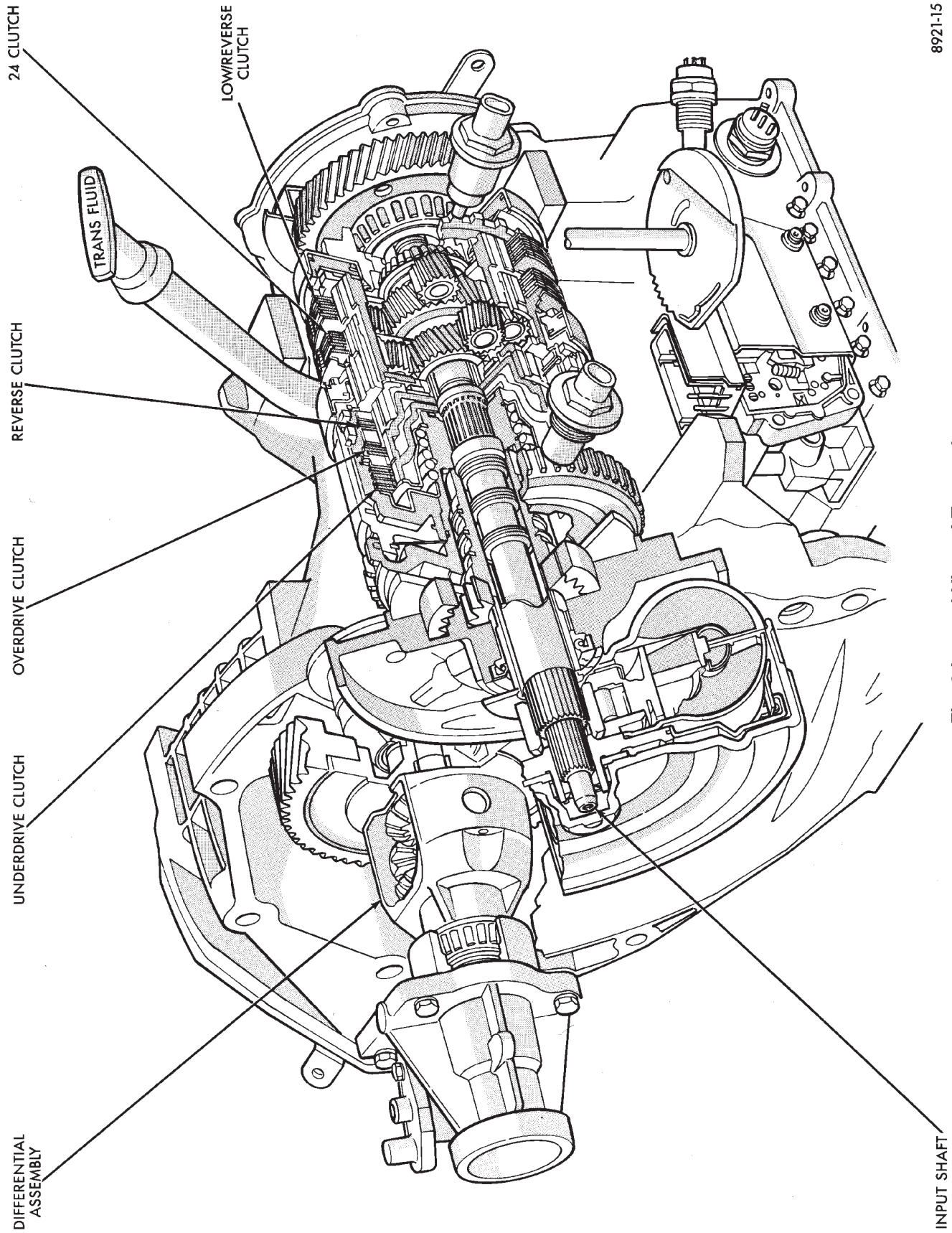

Fig. 1 Identification Tag Location

operating in 3 or L positions torque converter lockup occurs in direct gear for improved transmission cooling when towing trailers and on steep grades. If high engine coolant temperature occurs, the torque converter will also lock up in 2nd gear. The L position provides maximum engine braking for descending steep grades. Unlike most current transaxles, upshifts are provided to 2nd or direct gear at peak engine speeds if the accelerator is depressed. This provides engine over-speed protection and maximum performance.



8921-15

Fig. 2 Internal View of Transaxle

CLUTCH AND GEAR

The 4-speed electronic transaxle consists of:

- Three multiple-disc input clutches
- Two multiple disc grounded clutches
- Four hydraulic accumulators
- Two planetary gear sets

This provides four forward ratios and a reverse ratio. The clutch-apply pistons were designed with centrifugally balanced oil cavities so that quick response and good control can be achieved at any speed. A push/pull piston is incorporated for two of the three input clutches.

CAUTION: Some clutch packs appear similar, but they are not the same. Do not interchange clutch components as they might fail.

HYDRAULICS

The hydraulics of the new transaxle provide the manual shift lever select function, main line pressure regulation, and torque converter and cooler flow control. Oil flow to the friction elements is controlled directly by four solenoid valves. The hydraulics also include a unique logic-controlled “solenoid lock-up control valve”. This valve locks out the 1st gear reaction element with the application of 2nd, direct, or overdrive gear elements. It also redirects the 1st gear solenoid output so that it can control torque converter lockup operation. To regain access to 1st gear, a special sequence of solenoid commands must be used to unlock and move the solenoid lock-up control valve. This precludes any application of the 1st gear reaction element with other elements applied, unless specifically commanded the controller. It also allows one solenoid to control two friction elements.

Small, high-rate accumulators are provided in each controlled friction element circuit. These serve to absorb the pressure responses, and allow the controls to read and respond to changes that are occurring.

SOLENOIDS

Since the solenoid valves perform virtually all control functions, these valves must be extremely durable and tolerant of normal dirt particles. For that reason hardened-steel poppet and ball valves are used. These are free from any close operating clearances, and the solenoids operate the valves directly without any intermediate element. Direct operation means that these units must have very high output so that they can close against the sizeable flow areas and high line pressures. Fast response is also required to meet the control requirements.

Two of the solenoids are normally-venting and two are normally-applying; this was done to provide a default mode of operation. With no electrical power, the transmission provides 2nd gear in “OD,” “3,” or “L” shift lever positions. All other shift lever positions will

function normally. The choice of 2nd gear was made to provide adequate performance while still accommodating highway speeds.

SENSORS

There are three pressure switches to identify solenoid application and two speed sensors to read input (torque converter turbine) and output (parking sprag) speeds. There is also a position switch to indicate the manual shift lever position. The pressure switches are incorporated in an assembly with the solenoids. Engine speed, throttle position, temperature, etc., are also observed. Some of these signals are read directly from the engine control sensors; others are read from a multiplex circuit with the engine controller.

ELECTRONICS

The electronic control unit is located underhood in a potted, die cast aluminum housing with a sealed, 60-way connector.

ADAPTIVE CONTROLS

These controls function by reading the input and output speeds over 140 times a second and responding to each new reading. This provides the precise and sophisticated friction element control needed to make smooth clutch-to-clutch shifts for all gear changes. As with most automatic transaxles, all shifts involve releasing one element and applying a different element. In simplified terms, the upshift logic allows the releasing element to slip back wards slightly to ensure that it does not have excess capacity; the apply element is filled until it begins to make the speed change to the higher gear; its apply pressure is then controlled to maintain the desired rate of speed change until the shift is complete. The key to providing excellent shift quality is precision; for example, as mentioned, the release element for upshifts is allowed to slip backwards slightly; the amount of that slip is typically less than a total of 20 degrees. To achieve that precision, **the controller learns the characteristics of the particular transaxle that it is controlling. It learns the release rate of the releasing element and the apply time of the applying element. It also learns the rate at which the apply element builds pressure sufficient to begin making the speed change.** This method achieves more precision than would be possible with exacting tolerances. It can also adapt to any changes that occur with age or environment, for example, altitude, temperature, engine output, etc.

For kickdown shifts, the control logic allows the releasing element to slip and then controls the rate at which the input (and engine) accelerate; when the lower gear speed is achieved, the releasing element

reapplies to maintain that speed until the apply element is filled. This provides quick response since the engine begins to accelerate immediately and a smooth torque exchange since the release element can control the rate of torque increase. This control can make any power train feel more responsive without increasing harshness.

Adaptive controls respond to input speed changes. They compensate for changes in engine or friction element torque and provide good, consistent shift quality for the life of the transaxle.

ON-BOARD DIAGNOSTICS

These controls also provide comprehensive, on-board transaxle diagnostics. The information available can aid in transaxle diagnosis. For example, apply element buildup rate indicates solenoid performance. Also included are self-diagnostic functions which allow the technician to test the integrity of the electronic controls without requiring a road test. The controller continuously monitors its critical functions, records any malfunctions, and the number of engine starts since the last malfunction. The technician can use this information in the event of a customer complaint.

GENERAL DIAGNOSIS

CAUTION: Before attempting any repair on a Electronic Automatic Transaxle, check for fault codes with the DRBII. Always use the "Powertrain Diagnostic Test Procedure Manual."

Electronic automatic transaxle malfunctions may be caused by these general conditions:

- Poor engine performance
- Improper adjustments
- Hydraulic malfunctions
- Mechanical malfunctions
- Electronic malfunctions

Diagnosis of these problems should always begin by checking the easily accessible variables: fluid level and condition, gearshift cable adjustment. Then perform a road test to determine if the problem has been corrected or that more diagnosis is necessary. If the problem exists after the preliminary tests and corrections are completed, hydraulic pressure checks should be performed.

DIAGNOSIS GUIDE-VEHICLE WILL NOT MOVE

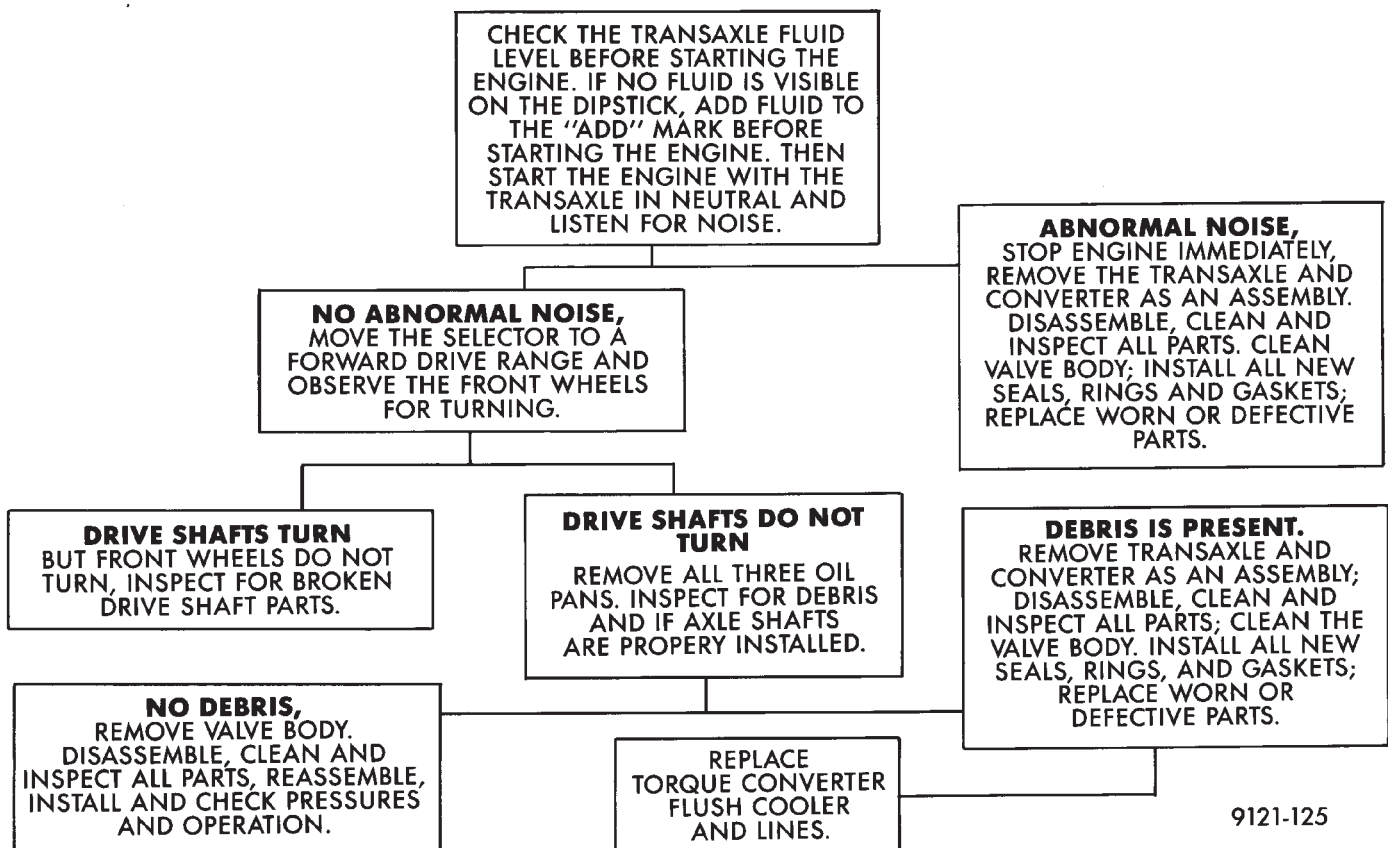



FAULT CODE CHART "A"

Fault Code Number	Condition	Possible Cause																										
		Low fluid level	Aeroloid fluid (high fluid level)	Worn or damaged reaction shaft support seal rings	Worn or damaged input shaft seal rings	Worn pump	Damaged or failed clutches:	UD clutch	OD clutch	Reverse clutch	2/4 clutch	L/R clutch	Damaged clutch seals	Worn or damaged accumulator seal rings	Plugged filter	Stuck/sticky valves	Solenoid switch valve	Lockup switch valve	Torque converter control valve	Regulator valve	Valve body leakage	Pressures too high	Internal solenoid leak	Torque converter lockup clutch failure	Faulty cooling system	Damaged speed sensor gear teeth	Planetary gear sets broken or seized	
21	OD clutch—pressure too low	X	X	X				X																				
22	2/4 clutch—pressure too low		X							X																		
23	2/4 clutch and OD clutch—pressures too low		X	X																								
24	L/R clutch—pressure too low		X								X																	
25	L/R clutch and OD clutches—pressures too low		X	X																								
26	L/R clutch and 2/4 clutches—pressures too low		X																									
27	OD, 2/4, and L/R clutches—pressures too low		X	X																								
31	OD clutch pressure switch response failure									X																		
32	2/4 pressure switch response failure										X																	
33	2/4 and O/D clutch pressure response failures													X														
37	Solenoid switch valve stuck in the LO position														X													
38	Partial lockup control out of range															X												
47	Solenoid switch valve stuck in the LR position															X												
50	Speed ratio default in reverse	X	X	X							X																	
51	Speed ratio default in 1st	X	X	X																								
52	Speed ratio default in 2nd	X	X	X																								
53	Speed ratio default in 3rd	X	X	X																								
54	Speed ratio default in 4th	X	X	X																								
60	Inadequate LR element volume	X										X																
61	Inadequate 2/4 element volume	X											X															
62	Inadequate OD element volume	X																				X						
63	Inadequate UD element volume	X																					X					

NOTE:
Code 36 is not stored alone. It is stored if a speed error (codes 50 through 58) is detected immediately after a shift. Look at the possible causes associated with the speed error code.

DIAGNOSIS GUIDE-FLUID LEAKS

VISUALLY INSPECT FOR SOURCE OF LEAK. IF THE SOURCE OF LEAK CANNOT BE READILY DETERMINED, CLEAN THE EXTERIOR OF THE TRANSAXLE. CHECK TRANSAXLE FLUID LEVEL. CORRECT IF NECESSARY.

THE FOLLOWING LEAKS MAY BE CORRECTED WITHOUT REMOVING THE TRANSAXLE:

- MANUAL LEVER SHAFT OIL SEAL
- PRESSURE GAUGE PLUGS
- NEUTRAL START SWITCH OIL PAN RTV
- OIL COOLER FITTINGS
- EXTENSION HOUSING TO CASE BOLTS
- SPEEDOMETER ADAPTER "O" RING.

EXTENSION HOUSING AXLE SEAL
DIFFERENTIAL BEARING RETAINER AXLE SEAL
REAR END COVER RTV
EXTENSION HOUSING "O" RING
DIFFERENTIAL BEARING RETAINER RTV.

THE FOLLOWING LEAKS REQUIRE REMOVAL OF THE TRANSAXLE AND TORQUE CONVERTER FOR CORRECTION

TRANSAXLE FLUID LEAKING FROM THE LOWER EDGE OF THE CONVERTER HOUSING; CAUSED BY FRONT PUMP SEAL, PUMP TO CASE SEAL, OR TORQUE CONVERTER WELD.

CRACKED OR POROUS TRANSAXLE CASE.

9121-126

DIAGNOSIS GUIDE-ABNORMAL NOISE

INSPECT AND CORRECT THE TRANSAXLE FLUID LEVEL. ROAD TEST TO VERIFY THAT AN ABNORMAL NOISE EXISTS. IDENTIFY THE TYPE OF NOISE, DRIVING RANGES, AND CONDITIONS WHEN THE NOISE OCCURS.

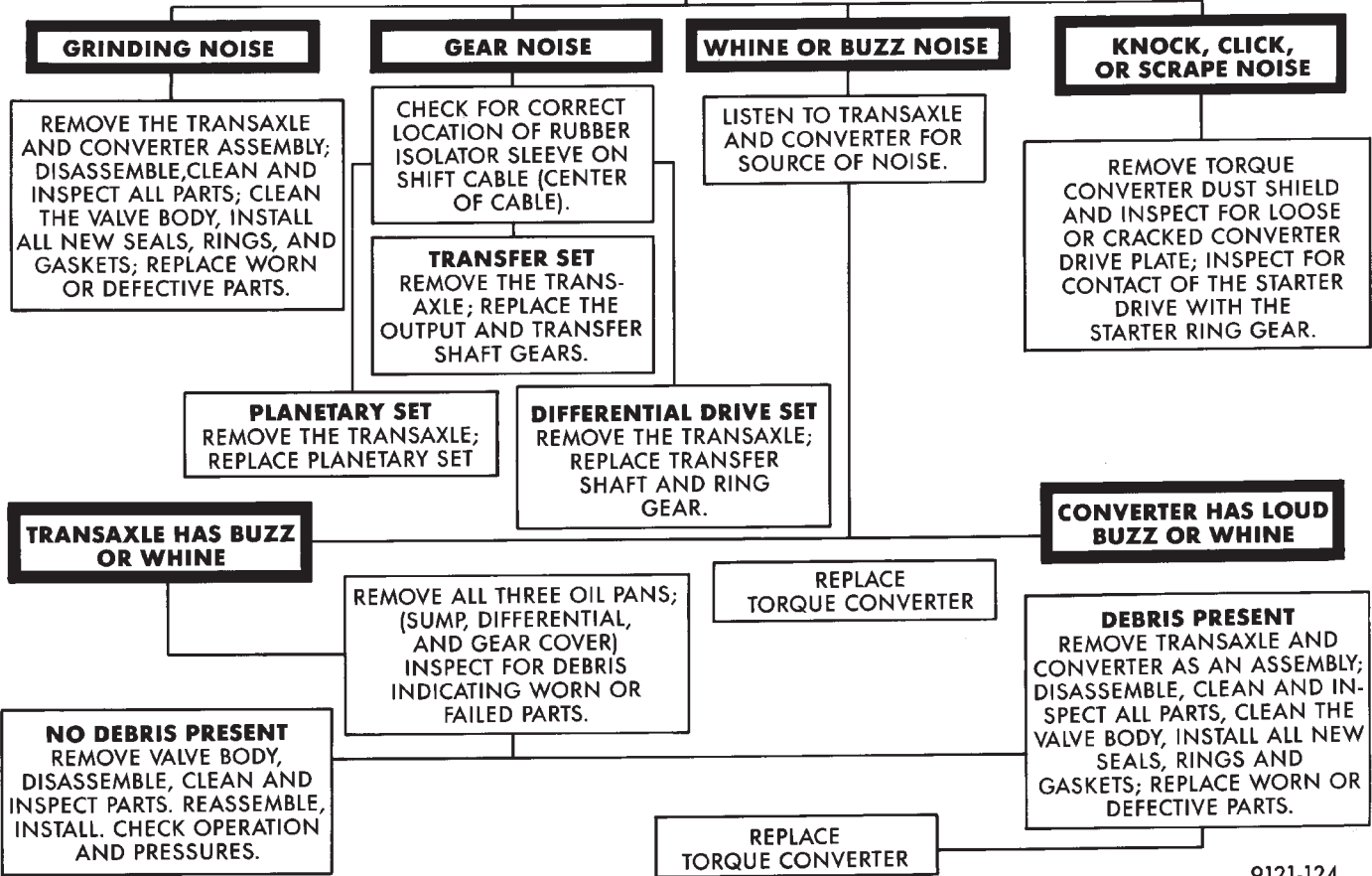

9121-124

FLUID LEVEL AND CONDITION

The transmission and differential sump have a common oil sump with a communicating opening between the two.

The torque converter fills in both the "P" Park and "N" Neutral positions. Place the selector lever in "P" Park to be sure that the fluid level check is accurate. **The engine should be running at idle speed for at least one minute, with the vehicle on level ground. This will assure complete oil level stabilization between differential and transmission.** The fluid should be at normal operating temperature (approximately 82 C. or 180 F.). The fluid level is correct if it is in the "HOT" region (cross-hatched area) on the oil level indicator.

Low fluid level can cause a variety of conditions because it allows the pump to take in air along with the fluid. As in any hydraulic system, air bubbles make the fluid spongy, therefore, pressures will be low and build up slowly.

Improper filling can also raise the fluid level too high. When the transaxle has too much fluid, the gears churn up foam and cause the same conditions which occur with a low fluid level.

In either case, the air bubbles can cause over heating, fluid oxidation, and varnishing, which can interfere with normal valve, clutch, and accumulator operation. Foaming can also result in fluid escaping from the transaxle vent where it may be mistaken for a leak.

Along with fluid level, it is important to check the condition of the fluid. When the fluid smells burned, and is contaminated with metal or friction material particles, a complete transaxle overhaul is needed. Be sure to examine the fluid on the dipstick closely. If there is any doubt about its condition, drain out a sample for a double check.

After the fluid has been checked, seat the dipstick fully to seal out water and dirt.

SELECTION OF LUBRICANT

It is important that the proper lubricant be used in these transmissions. MOPAR® ATF PLUS (Automatic Transmission Fluid-Type 7176) should be used to aid in assuring optimum transmission performance. Fluids of the type labeled DEXRON II Automatic Transmission Fluid is **not recommended**. DEXRON II can be used only if the recommended fluid is not available. If more than a small amount of Dexron fluid is used, shutter or shift quality problems may be encountered. It is important that the transmission fluid be maintained at the prescribed level using the recommended fluids.

SPECIAL ADDITIVES

Chrysler Corporation does not recommend the addition of any fluids to the transmission, other than the automatic transmission fluid listed above. An exception to this policy is the use of special dyes to aid in

detecting fluid leaks. The use of transmission sealers should be avoided, since they may adversely affect seals.

FLUID AND FILTER CHANGE

When the factory fill fluid is changed, only fluids of the type labeled MOPAR® ATF PLUS (Automatic Transmission fluid) Type 7176 should be used. A filter change should be made at the time of the oil change. Also the magnet (on the inside of the oil pan) should be cleaned with a clean, dry cloth.

If the transaxle is disassembled for any reason, the fluid and filter should be changed.

FLUID DRAIN AND REFILL

(1) Raise vehicle on a hoist (See Lubrication, "Group 0"). Place a drain container with a large opening, under transaxle oil pan.

(2) Loosen pan bolts and tap the pan at one corner to break it loose allowing fluid to drain, then remove the oil pan.

(3) Install a new filter and O-ring on bottom of the valve body.

(4) Clean the oil pan and magnet. Reinstall pan using Mopar® Silicone Rubber Adhesive Sealant or equivalent. Tighten oil pan bolts to 19 N•m (165 in. lbs.).

(5) Pour four quarts of MOPAR® ATF PLUS (Automatic Transmission Fluid) Type 7176 through the fill tube.

(6) Start engine and allow to idle for at least one minute. Then, with parking and service brakes applied, move selector lever momentarily to each position, ending in the park or neutral position.

(7) Add sufficient fluid to bring level to 1/8 inch below the ADD mark (Fig. 3).

Recheck fluid level after transaxle is at normal operating temperature. The level should be in the HOT region (Fig. 3).

To prevent dirt from entering transaxle, make certain that dipstick is seated into the dipstick fill tube (Fig. 4).

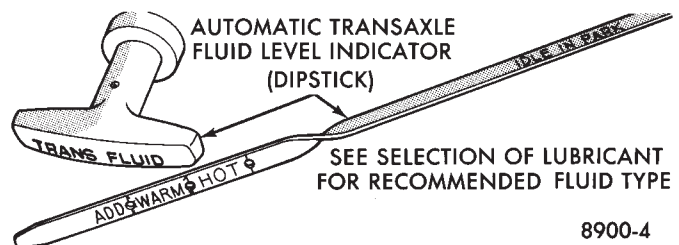

8900-4

Fig. 3 Oil Level Indicator

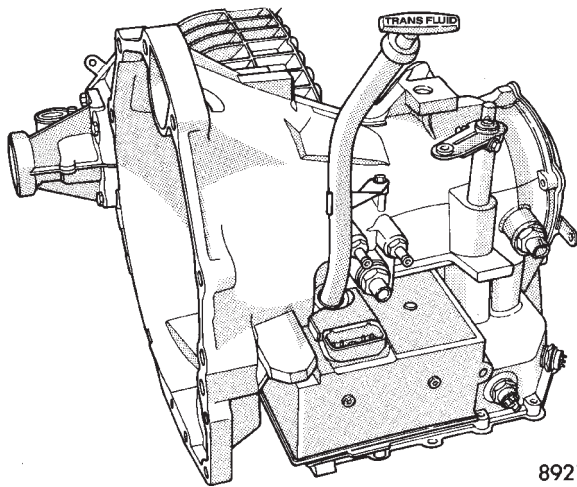

Fig. 4 Oil Level Indicator Location

ROAD TEST

Prior to performing a road test, be certain that the fluid level and condition, and control cable adjustment have been checked and approved.

During the road test, the transaxle should be operated in each position to check for slipping and any variation in shifting.

If vehicle operates properly at highway speeds, but has poor through-gear acceleration, the torque converter stator overrunning clutch may be slipping. If through-gear acceleration is normal, but abnormally high throttle opening is required to maintain highway speeds, the torque converter stator clutch may have seized. Both of these stator defects require replacement of the torque converter.

In most cases, the clutch that is slipping can be determined by noting the transaxle operation in all selector positions. Then comparing which internal units are applied in those positions. The "Elements in Use Chart" provides a basis for road test analysis.

The process of eliminating can be used to detect any unit which slips and to confirm proper operation of good units. However, although road test analysis can usually diagnose slipping units, the actual cause of the malfunction usually can not be decided. Practically any condition can be caused by leaking hydraulic circuits or sticking valves.

ELEMENTS IN USE AT EACH POSITION OF THE SELECTOR LEVER

Shift Lever Position	Start Safety	Park Sprag	CLUTCHES				
			Underdrive	Overdrive	Reverse	2/4	Low/Reverse
P — PARK	X	X					X
R — REVERSE					X		X
N — NEUTRAL	X						X
OD — OVERDRIVE							
First			X				X
Second			X			X	
Direct			X	X			
Overdrive				X		X	
3 — DRIVE GEAR*							
First			X				X
Second			X			X	
Direct			X	X			
L — LOW*							
First			X				X
Second			X			X	
Direct			X	X			

*Vehicle upshift and downshift speeds are increased when in these selector positions.

HYDRAULIC PRESSURE TESTS

Pressure testing is a very important step in the diagnostic procedure. These tests usually reveal the cause of most transaxle problems.

Before performing pressure tests, be certain that fluid level and condition, and shift cable adjustments have been checked and approved. Fluid must be at operating temperature 66 to 93 degrees C. (150 to 200 degrees F.).

Install an engine tachometer, raise vehicle on hoist which allows front wheels to turn, and position tachometer so it can be read.

Attach 150 psi gauges to ports required for test being conducted. A 300 psi gauge (C-3293) is required for reverse pressure test.

Test port locations are shown in (Figure 1).

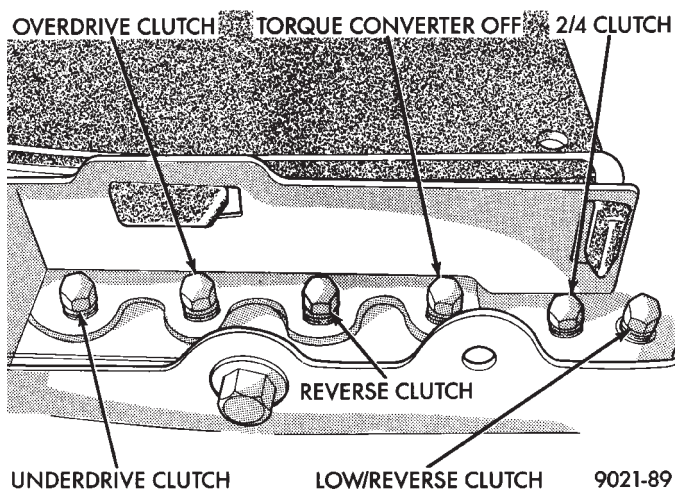

Fig. 1 Pressure Taps

TEST ONE (SELECTOR IN "L" 1ST GEAR)

(1) Attach pressure gauge to the low/reverse clutch tap.

(2) Move selector lever to the L position.

(3) Allow vehicle wheels to turn and increase throttle opening to achieve an indicated vehicle speed to 20 mph.

(4) Low/reverse clutch pressure should read 115 to 145 psi.

(5) This test checks pump output, pressure regulation and condition of the low/reverse clutch hydraulic circuit and shift schedule.

TEST TWO (SELECTOR IN "3" 2ND GEAR)

(1) Attach gauge to the underdrive clutch tap.

(2) Move selector lever to the "3" position.

(3) Allow vehicle wheels to turn and increase throttle opening to achieve an indicated vehicle speed of 30 mph.

(4) Underdrive clutch pressure should read 110 to 145 psi.

(5) This test checks the underdrive clutch hydraulic circuit as well as the shift schedule.

TEST THREE (OVERDRIVE CLUTCH CHECK)

(1) Attach gauge to the overdrive clutch tap.

(2) Move selector lever to the "circle D" position.

(3) Allow vehicle wheels to turn and increase throttle opening to achieve an indicated vehicle speed of 20 mph.

(4) Overdrive clutch pressure should read 74 to 95 psi.

(5) Move selector lever to the "3" position and increase indicated vehicle speed to 30 mph.

(6) The vehicle should be in second gear and overdrive clutch pressure should be less than 5 psi.

(7) This test checks the overdrive clutch hydraulic circuit as well as the shift schedule.

TEST FOUR (SELECTOR IN "CIRCLE D" OVERDRIVE GEAR)

(1) Attach gauge to the 2/4 clutch tap.

(2) Move selector lever to the "circle D" position.

(3) Allow vehicle front wheels to turn and increase throttle opening to achieve an indicated vehicle speed of 30 mph.

(4) The 2/4 clutch pressure should read 75 to 95 psi.

(5) This test checks the 2/4 clutch hydraulic circuit.

TEST FIVE (SELECTOR IN "CIRCLE D" OVERDRIVE LOCKUP)

(1) Attach gauge to the lockup off pressure tap.

(2) Move selector lever to the "circle D" position.

(3) Allow vehicle wheels to turn and increase throttle opening to achieve an indicated vehicle speed of 50 mph.

CAUTION: Both wheels must turn at the same speed.

(4) Lockup off pressure should be less than 5 psi.

(5) This test checks the lockup clutch hydraulic circuit.

TEST SIX (SELECTOR IN REVERSE)

(1) Attach gauge to the reverse clutch tap.

(2) Move selector lever to the reverse position.

(3) Read reverse clutch pressure with output stationary (foot on brake) and throttle opened to achieve 1500 rpm.

(4) Reverse clutch pressure should read 165 to 235 psi.

(5) This test checks the reverse clutch hydraulic circuit.

PRESSURE CHECK SPECIFICATIONS
PRESSURE TAP ORDER ON CASE FROM BELLHOUSING TO END COVER
ALL PRESSURE SPECIFICATIONS ARE PSI

(on hoist, with front wheels free to turn)

Gear Selector Position	Actual Gear	PRESSURE TAPS					
		Under-Drive Clutch	Over-Drive Clutch	Reverse Clutch	Lockup Off	2/4 Clutch	Low/Reverse Clutch
PARK * 0 mph	PARK	0-2	0-5	0-2	60-110	0-2	115-145
REVERSE * 0 mph	REVERSE	0-2	0-7	165-235	50-100	0-2	165-235
NEUTRAL * 0 mph	NEUTRAL	0-2	0-5	0-2	60-110	0-2	115-145
L # 20 mph	FIRST	110-145	0-5	0-2	60-110	0-2	115-145
3 # 30 mph	SECOND	110-145	0-5	0-2	60-110	115-145	0-2
3 # 45 mph	DIRECT	75-95	75-95	0-2	60-90	0-2	0-2
OD # 30 mph	OVERDRIVE	0-2	75-95	0-2	60-90	75-95	0-2
OD # 50 mph	OVERDRIVE LOCKUP	0-2	75-95	0-2	0-5	75-95	0-2

* Engine speed at 1500 rpm

CAUTION: Both front wheels must be turning at same speed.

9221-94

TEST RESULT INDICATIONS

- (1) If proper line pressure is found in any one test, the pump and pressure regulator are working properly.
- (2) Low pressure in all positions indicates a defective pump, a clogged filter, or a stuck pressure regulator valve.
- (3) Clutch circuit leaks are indicated if pressures do not fall within the specified pressure range.
- (4) If the overdrive clutch pressure is greater than 5 psi in step (6) of Test Three, a worn reaction shaft seal ring is indicated.

CLUTCH AIR PRESSURE TESTS

Inoperative clutches can be located using a series of tests by substituting air pressure for fluid pressure (Figs. 2 and 3). The clutches may be tested by applying air pressure to their respective passages after the valve body has been removed and Tool 6056 has been installed. To make air pressure tests, proceed as follows:

The compressed air supply must be free of all dirt and moisture. Use a pressure of 30 psi.

Remove oil pan and valve body (See Valve body-Recondition).

OVERDRIVE CLUTCH

Apply air pressure to the overdrive clutch apply passage and watch for the push/pull piston to move forward. The piston should return to its starting position when the air pressure is removed.

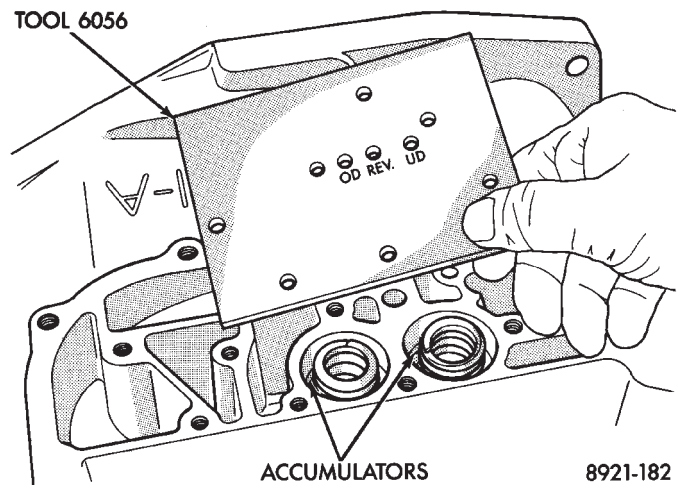

Fig. 2 Air Pressure Test Plate

REVERSE CLUTCH

Apply air pressure to the reverse clutch apply passage and watch for the push/pull piston to move rearward. The piston should return to its starting position when the air pressure is removed.

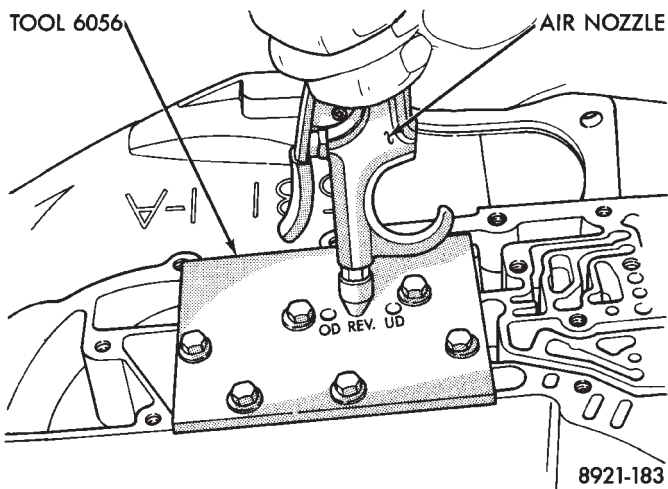

Fig. 3 Testing Reverse Clutch

2/4 CLUTCH

Apply air pressure to the feed hole located on the 2/4 clutch retainer. Look in the area where the 2/4 piston contacts the first separator plate and watch carefully for the 2/4 piston to move rearward. The piston should return to its original position after the air pressure is removed.

LOW/REVERSE CLUTCH

Apply air pressure to the low/reverse clutch feed hole (rear of case, between 2 bolt holes). Then, look in the area where the low/reverse piston contacts the first separator plate and watch carefully for the piston to move forward. The piston should return to its original position after the air pressure is removed.

UNDERDRIVE CLUTCH

Because this clutch piston cannot be seen, its operation is checked by function. Air pressure is applied to the low/reverse and the 2/4 clutches. This locks the output shaft. Use a piece of rubber hose wrapped around the input shaft and a pair of clamp-on pliers to turn the input shaft. Next apply air pressure to the underdrive clutch. The input shaft should not rotate with hand torque. Release the air pressure and confirm that the input shaft will rotate.

FLUID LEAKAGE-TRANSAXLE TORQUE CONVERTER HOUSING AREA

(1) Check for source of leakage.

Since fluid leakage at or around the torque converter area may originate from an engine oil leak, the area should be examined closely. Factory fill fluid is dyed red and, therefore, can be distinguished from engine oil.

(2) Prior to removing the transaxle, perform the following checks:

When leakage is determined to originate from the transaxle, check fluid level prior to removal of the transaxle and torque converter.

High oil level can result in oil leakage out the vent in the manual shaft. If the fluid level is high, adjust to proper level.

After performing this operation, inspect for leakage. If a leak persists, perform the following operation on the vehicle to determine if it is the torque converter or transaxle that is leaking.

Possible sources of transaxle torque converter area fluid leakage are:

- (1) Torque converter hub seal.
 - Seal lip cut, check torque converter hub finish.
 - Bushing moved and/or worn.
 - Oil return hole in pump housing plugged or omitted.
 - Seal worn out (high-mileage vehicles).
- (2) Fluid leakage at the outside diameter from pump housing O-ring.
- (3) Fluid leakage at the front pump to case bolts. Check condition of washers on bolts and use new bolts, if necessary.
- (4) Fluid leakage due to case or front pump housing porosity.

TORQUE CONVERTER LEAKAGE

Possible sources of torque converter leakage are:

- Torque converter weld leaks at the out side (peripheral) weld.
- Torque converter hub weld.

Hub weld is inside and not visible. Do not attempt to repair. Replace torque converter.

LEAKAGE TEST PROBE

- (1) Remove torque converter housing dust shield.
- (2) Clean the inside of torque converter housing (lower area) as dry as possible. A solvent spray followed by compressed air drying is preferable.
- (3) Fabricate and fasten test probe (Fig. 4) securely to convenient dust shield bolt hole. Make certain torque converter is cleared by test probe. Tool must be clean and dry.

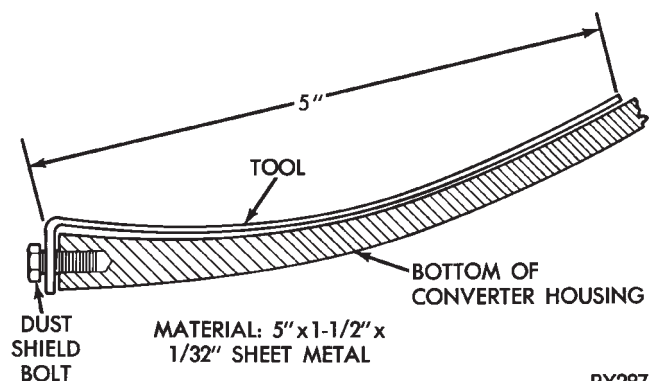

RY287

Fig. 4 Leak Locating Test Probe Tool

(4) Run engine at approximately 2,500 rpm with transaxle in neutral, for about 2 minutes. Transaxle must be at operating temperature.

(5) Stop engine and carefully remove tool.

(6) If upper surface of test probe is dry, there is no torque converter leak. A path of fluid across probe indicates a torque converter leak. Oil leaking under the probe is coming from the transaxle torque converter area.

(7) Remove transaxle and torque converter assembly from vehicle for further investigation. The fluid should be drained from the transaxle. Reinstall oil pan (with Mopar® Silicone Rubber Adhesive Sealant or equivalent) at specified torque.

AIR PRESSURE TEST OF TRANSAXLE

Fabricate equipment needed for test as shown in Figures 5 and 6.

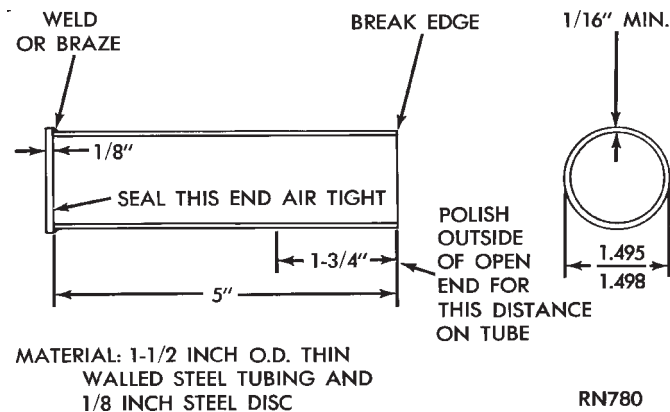

Fig. 5 Torque Converter Hub Seal Cup

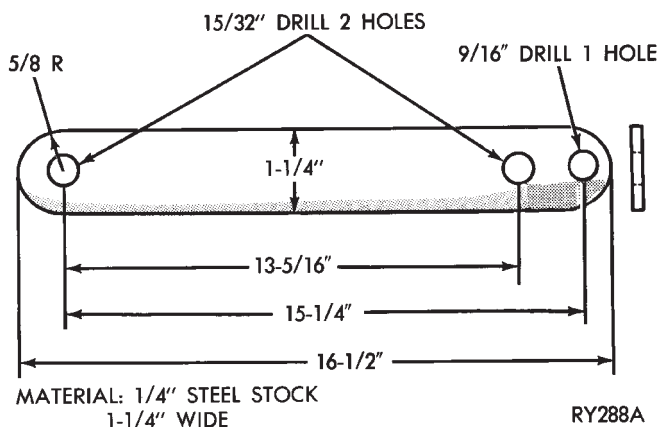

Fig. 6 Hub Seal Cup Retaining Strap

The transaxle should be prepared for pressure test as follows after removal of the torque converter:

(1) Plug dipstick tube and plug oil cooler line fitting. Remove vent from manual shaft and install a 1/8 inch pipe plug.

CAUTION: Prevent manual shaft rotation during installation and removal.

(2) With rotary motion, install converter hub seal cup over input shaft, and through the converter hub seal until the cup bottoms against the pump gear lugs. Secure with cup retainer strap (Fig. 6) using starter upper hole and opposite bracket hole.

(3) Attach and clamp hose from nozzle of Tool C-4080 to the upper cooler line fitting position in case.

CAUTION: Do not, under any circumstances, pressurize a transaxle to more than 10 psi.

(4) Pressurize the transaxle using Tool C-4080 until the pressure gauge reads 8 psi. Position transaxle so that pump housing and case front may be covered with soapy solution of water. Leaks are sometimes caused by porosity in the case or pump housing.

If a leak source is located, that part and all associated seals, O-rings, and gaskets should be replaced with new parts.

GEARSHIFT LINKAGE ADJUSTMENT

Normal operation of the PRNDL and neutral safety switch provides a quick check to confirm proper manual linkage adjustment.

Move the selector level slowly upward until it clicks into the "P" Park notch in the selector gate. If the starter will operate the "P" position is correct.

After checking "P" position, move the selector slowly toward "N" Neutral position until lever drops at the end of the "N" stop. If the starter will also operate at this point the gearshift linkage is properly adjusted. If adjustment is required, refer to gearshift linkage adjustment in Maintenance and Adjustments and refer to DRBII in the "Diagnostic Test Procedure Manual."

CAUTION: When it is necessary to disassemble linkage cable from levers, which use plastic grommets as retainers, the grommets should be replaced with new grommets. Use a prying tool to force rod from grommet in lever, then cut away old grommet. Use pliers to snap new grommet into lever and rod into grommet.

- (1) Set parking brake.
- (2) Place gearshift lever in "P" (PARK) position.
- (3) Loosen clamp bolt on gearshift cable bracket.
- (4) Column shift: Insure that preload adjustment spring engages fork on transaxle bracket.
- (5) Pull the shift lever by hand all the way to the front detent position (PARK) and tighten lock screw to 11 N•m (100 in. lbs.). Gearshift linkage should now be properly adjusted.

(6) Check adjustment as follows:

(a) Detent position for neutral and drive should be within limits of hand lever gate stops.

(b) Key start must occur only when shift lever is in park or neutral positions.

(7) To remove button assembly, completely remove knob attaching fasteners. Pull knob up sharply. Proceed as outlined in console removal, "Group 23."

After console is back in place, install knob and button by reversing the above procedure.

DISTANCE SENSOR GEAR

When the distance sensor is removed for any reason, a NEW O-ring must be installed on its outside diameter.

REMOVAL AND INSTALL

(1) Remove harness connector from sensor. Make sure weatherseal stays on harness connector.

(2) Remove bolt securing the distance sensor in the extension housing.

(3) Carefully pull sensor and pinion gear assembly out of extension housing.

(4) Remove pinion gear from sensor.

(5) To install, reverse the above procedure. Make sure extension housing and sensor flange are clean prior to installation. Always use a NEW sensor O-ring.

(6) Tighten securing bolt to 7 N•m (60 in. lbs.). Tighten speedometer cable to 4 N•m (35 in. lbs.).

ALUMINUM THREAD REPAIR

Damaged or worn threads in the aluminum transaxle case and valve body can be repaired by the use of Heli-Coils, or equivalent. This repair consists of drilling out the worn-out damaged threads. Then tapping the hole with a special Heli-Coil tap, or equivalent, and installing a Heli-Coil insert, or equivalent, into the hole. This brings the hole back to its original thread size.

Heli-Coil, or equivalent, tools and inserts are readily available from most automotive parts suppliers.

OIL COOLERS AND TUBES REVERSE FLUSHING

When a transaxle failure has contaminated the fluid, the oil cooler(s) must be flushed and the cooler bypass valve in the transaxle must be replaced. The torque converter must also be replaced with an exchange unit. This will insure that metal particles or sludged oil are not later transferred back into the reconditioned (or replaced) transaxle.

CAUTION: If the vehicle is equipped with two oil coolers (one in the radiator tank, one in front of the radiator) they must be flushed separately. Do not attempt to flush both coolers at one time.

(1) Disconnect the cooler lines at the transmission.

(2) Using a hand suction gun filled with mineral spirits, reverse flush the cooler by forcing mineral spirits into the **From Cooler** line of the cooler (Fig. 1). Catch the exiting spirits from the **To Cooler** line. Observe for the presence of debris in the exiting fluid. Continue until fluid exiting is clear and free from debris.

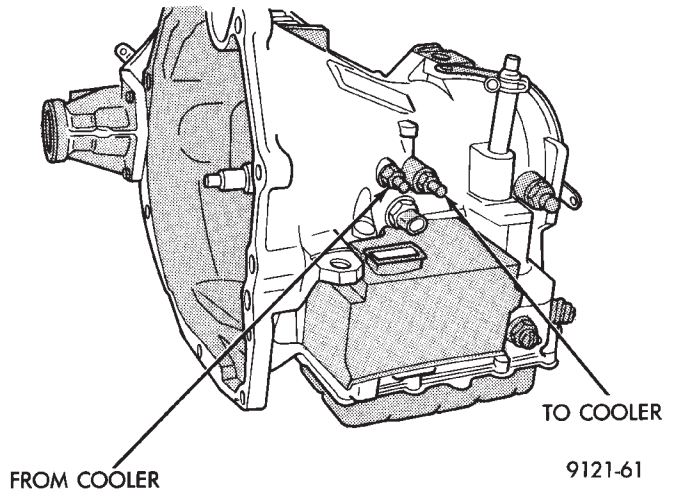

Fig. 1 Cooler Line Location

(3) Using compressed air in intermittent spurts, blow any remaining mineral spirits from the cooler, again in the reverse direction.

(4) To remove any remaining mineral spirits from the cooler, one (1) quart of automatic transmission fluid should be pumped through the cooler before reconnecting.

(5) If at any stage of the cleaning process, the cooler does not freely pass fluid, the cooler must be replaced.

OIL COOLER FLOW CHECK

After the new or repaired transmission has been installed and filled to the proper level with automatic transmission fluid, the flow should be checked using the following procedure:

(1) Disconnect the **From cooler** line at the transmission and place a collecting container under the disconnected line.

(2) Run the engine **at curb idle speed**, with the shift selector in neutral.

(3) If the fluid flow is intermittent or it takes more than 20 seconds to collect one quart of automatic transmission fluid, the cooler should be replaced.

CAUTION: WITH THE FLUID SET AT THE PROPER LEVEL, FLUID COLLECTION SHOULD NOT EXCEED (1) QUART OR INTERNAL DAMAGE TO THE TRANSMISSION MAY OCCUR.

(4) If flow is found to be within acceptable limits, reconnect the cooler line and fill transmission to the proper level, using the approved type of automatic transmission fluid.

TRANSAXLE REMOVAL AND INSTALLATION

Transaxle removal does NOT require engine removal.

See Group 7-Cooling, to drain engine cooling system and remove coolant return extension (3.0 liter engine only).

On vehicles equipped with All Wheel Drive, the power transfer unit (P.T.U.) must be removed before removing the transaxle. Refer to P.T.U Removal and Installation in this section for procedures.

(1) The transaxle and torque converter must be removed as an assembly; otherwise, the torque converter drive plate, pump bushing or oil seal may be damaged. The drive plate will not support a load; therefore, none of the weight of the transaxle should be allowed to rest on the drive plate during removal.

(2) Disconnect negative battery cable.

(3) Disconnect transaxle shift linkage.

(4) Install engine support fixture and support engine (Fig.1).

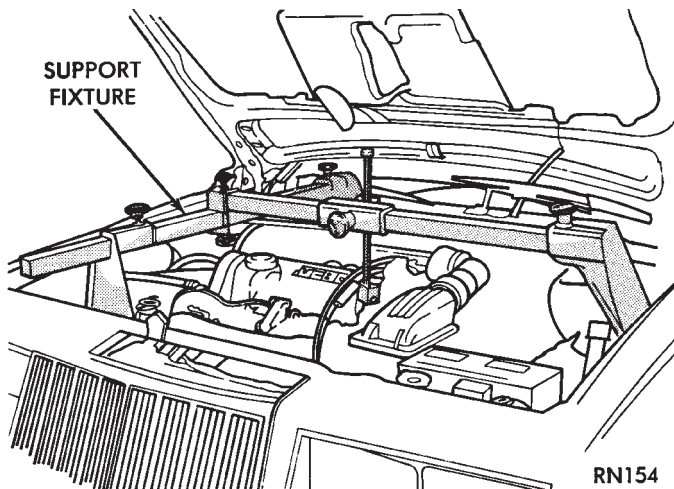

Fig. 1 Engine Support Fixture (Typical)

(5) Remove bell housing upper bolts.

(6) Raise vehicle. Remove front wheels. Refer to "Suspension, Group 2" to remove wheel hub nut and both drive shafts.

(7) Remove left plastic splash to gain access to the transaxle (Fig. 2).

(8) Remove torque converter dust shield to gain access to torque converter bolts (Fig. 3).

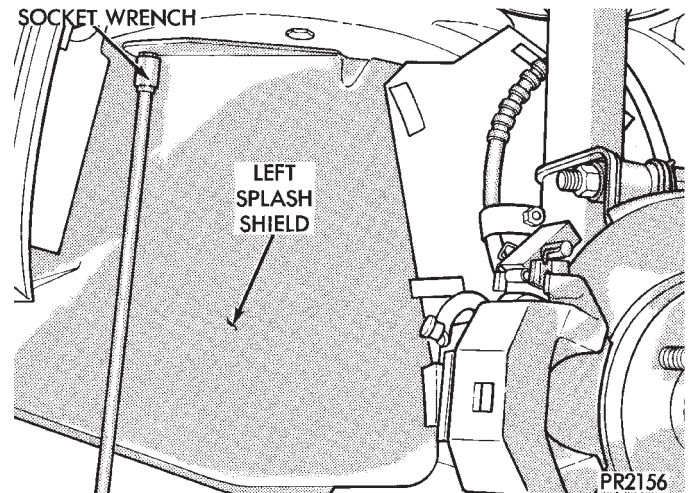

Fig. 2 Remove Left Splash Shield

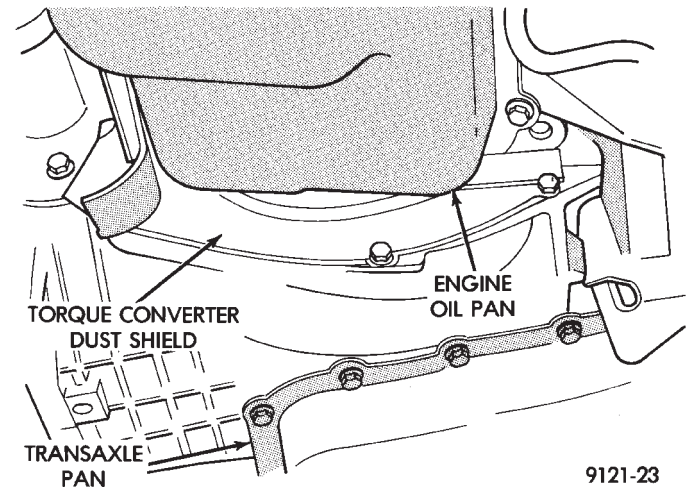

Fig. 3 Remove Torque Converter Dust Shield



(9) Mark torque converter and drive plate with chalk, for reassembly. Remove torque converter mounting bolts.

(10) Disconnect electrical connectors at PRNDL switch and neutral safety switch (Fig. 4).

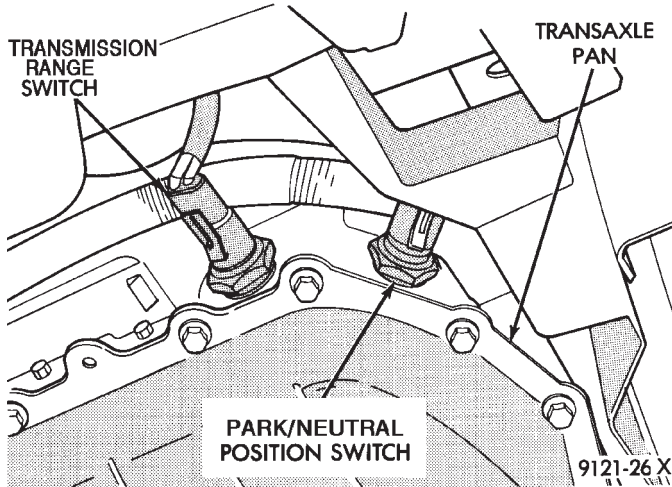

Fig. 4 Disconnect PRNDL Switch and Neutral Safety Switch

(11) Remove front engine mount insulator and bracket.

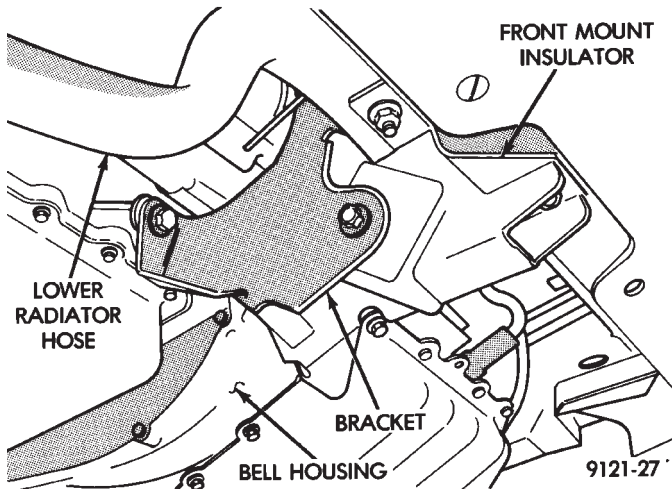

Fig. 5 Remove Front Engine Mount

(12) On vehicles equipped with D.I.S. ignition system, remove crankshaft position sensor from bell housing (Fig. 6). For installation procedure refer to section 8D of this service manual.

CAUTION: Failure to remove the crankshaft position sensor from the bell housing could cause damage to the sensor or the torque converter drive plate during transmission removal or installation.

(13) Disconnect and remove vehicle distance sensor (Fig. 7).

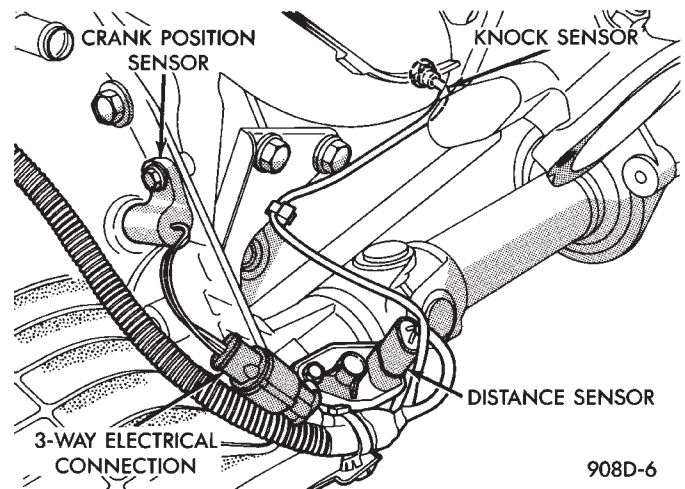

Fig. 6 Remove Crank Position Sensor (D.I.S. Ignition Only)

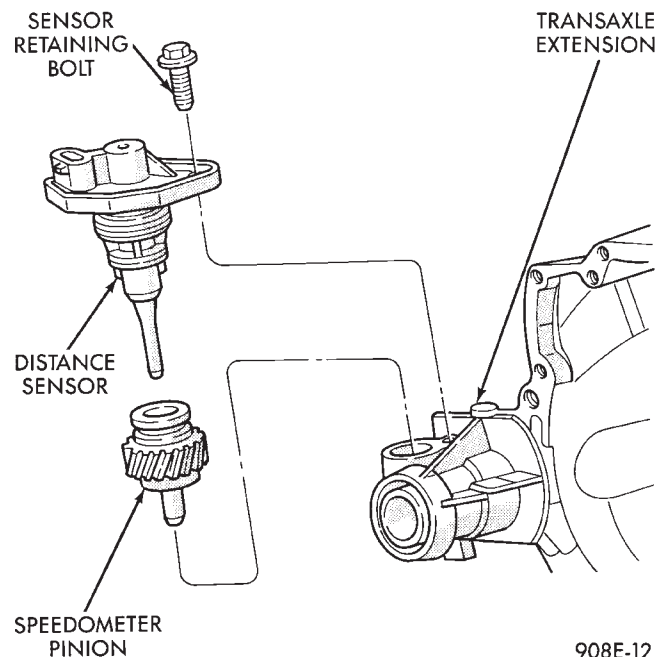

Fig. 7 Remove Distance Sensor

(14) Remove starter bolts and set starter aside. Do not allow the starter to hang from battery cable (Fig. 8).

(15) Position transmission jack securely under transaxle (Fig. 9).

(16) With transmission jack in position, remove the left transmission mount (Fig. 10).

(17) Carefully lower the transaxle assembly from vehicle.

When installing transaxle, reverse the above procedure.

Check and/or adjust gear shift cable.

Refill transaxle with MOPAR® ATF PLUS (Automatic Transmission Fluid) Type 7176 or equivalent.

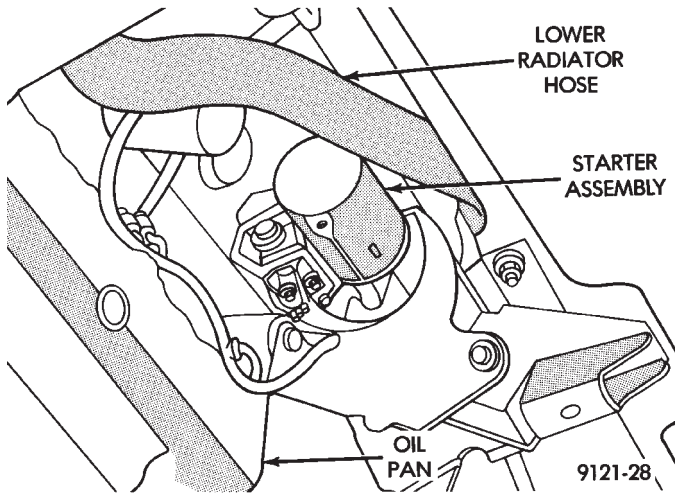

Fig. 8 Remove Starter Assembly

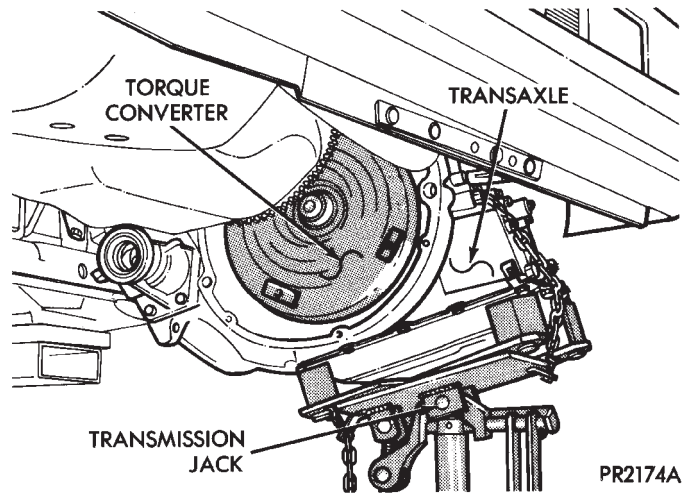

Fig. 11 Lower Transaxle Assembly
SOLENOID ASSEMBLY-REPLACE

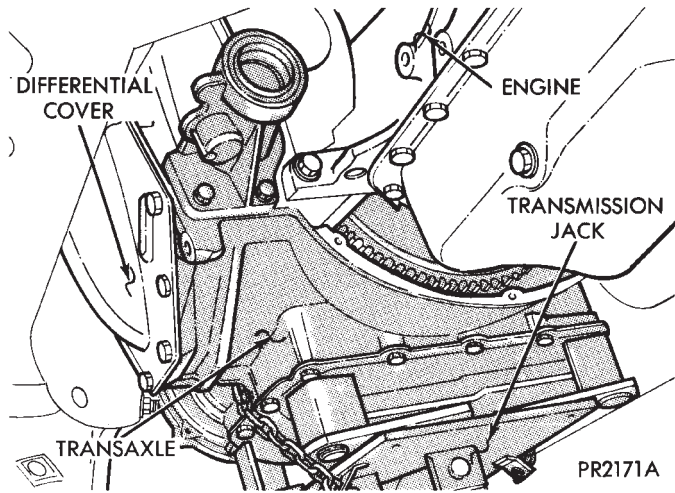

Fig. 9 Position Transmission Jack

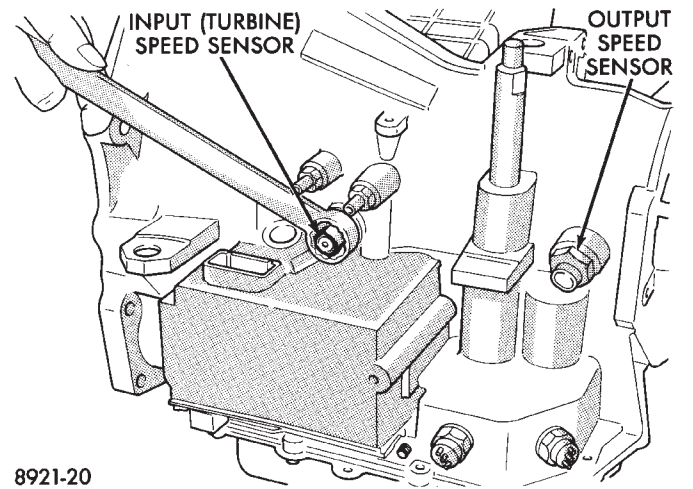

Fig. 1 Input Speed Sensor

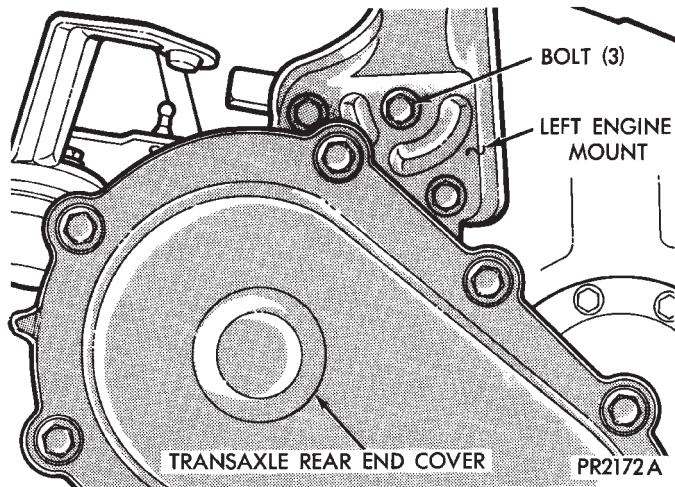

Fig. 10 Remove Left Transmission Mount

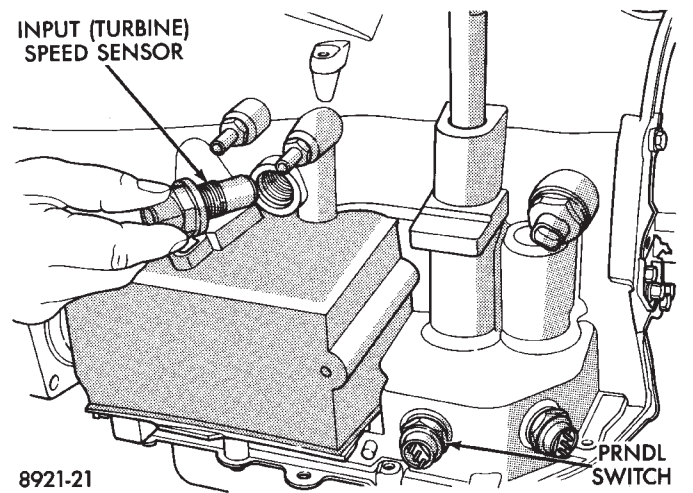

Fig. 2 Input Speed Sensor Removed

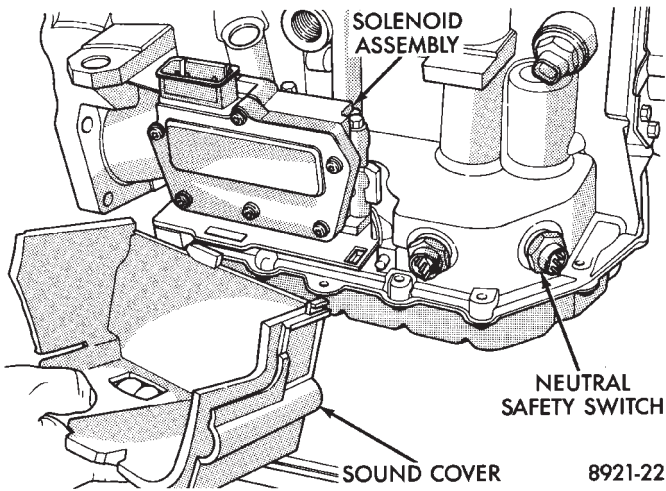

Fig. 3 Sound Cover

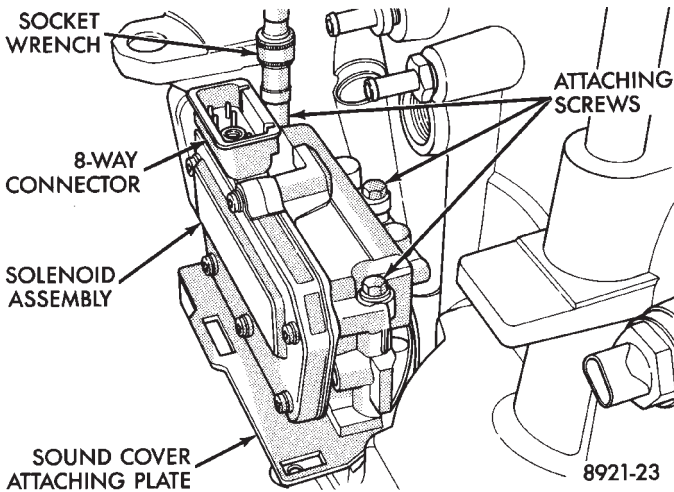

Fig. 4 Attaching Screws

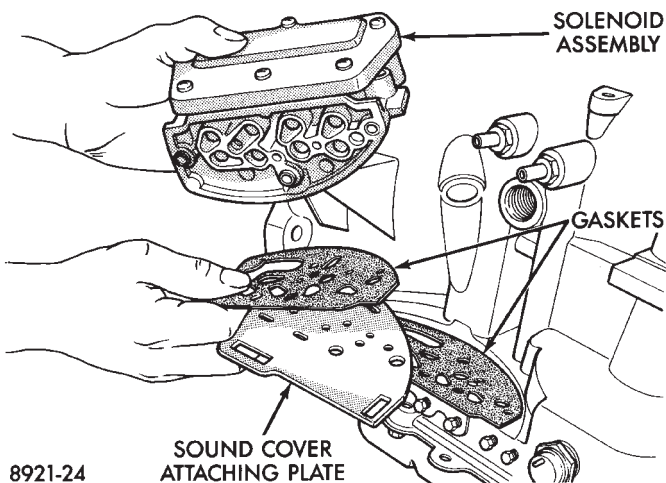

Fig. 5 Solenoid Assembly

PRNDL SWITCH

CAUTION: Switch seal washer must be seated properly before tightening switch. Failure to do so may

result in leakage of transmission fluid.

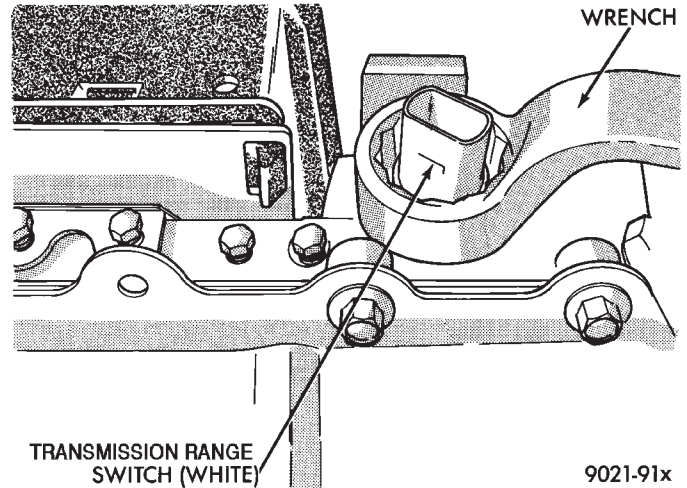

Fig. 6 PRNDL Switch

NEUTRAL SAFETY SWITCH

CAUTION: Switch seal washer must be seated properly before tightening switch. Failure to do so may result in leakage of transmission fluid.

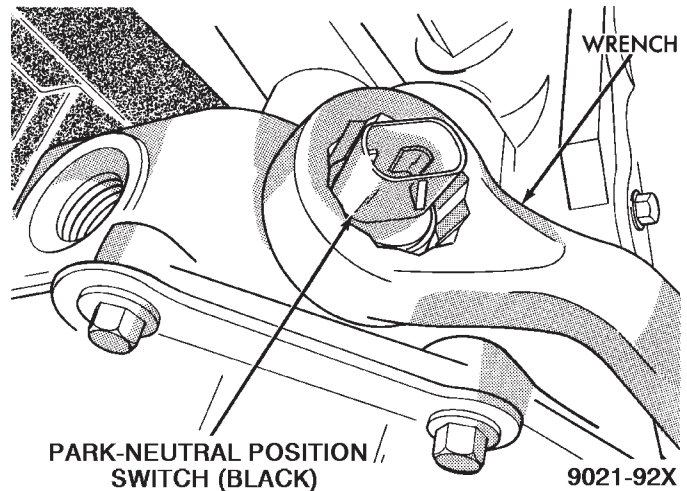

Fig. 7 Neutral Safety Switch

SPEED SENSOR-INPUT

CAUTION: When disconnecting speed sensor connector, be sure that the weather seal does not fall off or remain in old sensor.

The input speed sensor is located to the right of the manual shift lever.

SPEED SENSOR-OUTPUT

The output speed sensor is located to the left of the manual shift lever (Fig. 8).

CAUTION: When disconnecting speed sensor connector, be sure that the weather seal does not fall off or remain in old sensor.

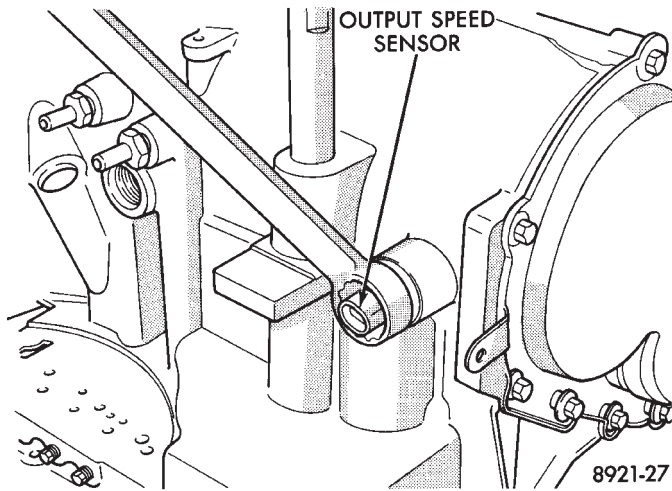

Fig. 8 Output Speed Sensor

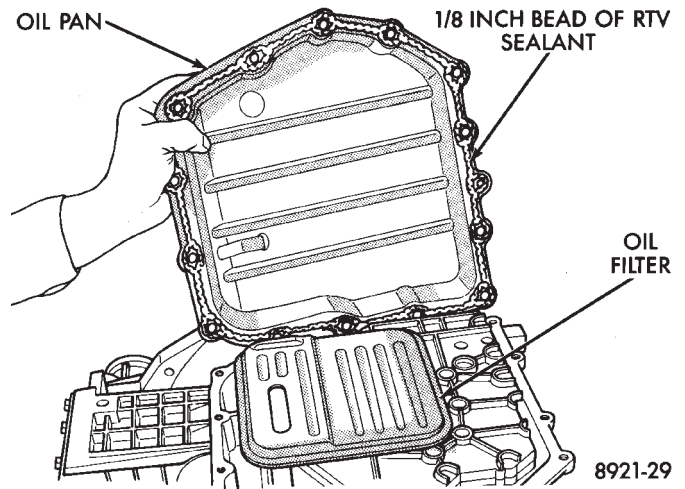

Fig. 2 Oil Pan

TRANSAXLE-RECONDITION

Prior to removing any transaxle subassemblies, plug all openings and thoroughly clean exterior of the unit, preferably by steam. Cleanliness through entire disassembly and assembly cannot be overemphasized. When disassembling, each part should be washed in a suitable solvent, then dried by compressed air. **Do not wipe parts with shop towels.** All mating surfaces in the transaxles are accurately machined; therefore, careful handling of all parts must be exercised to avoid nicks or burrs.

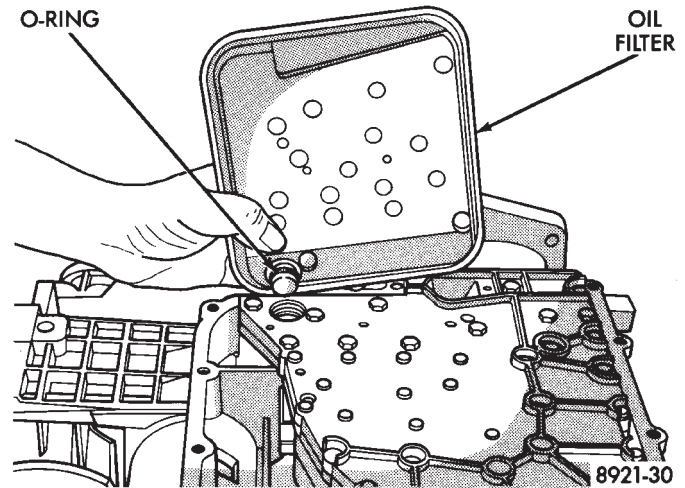

Fig. 3 Oil Filter

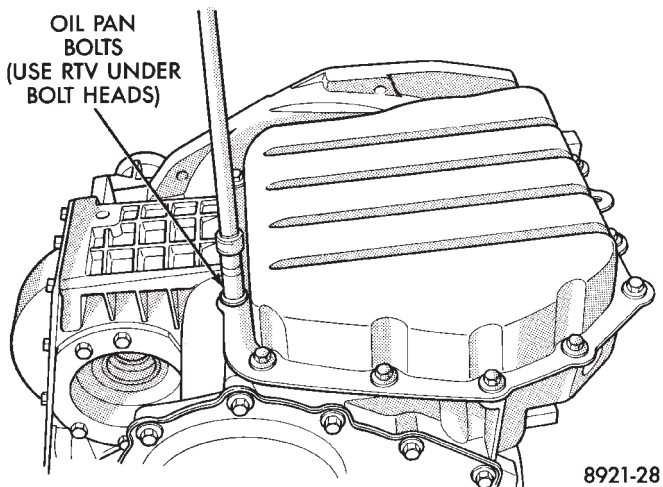

Fig. 1 Oil Pan Bolts

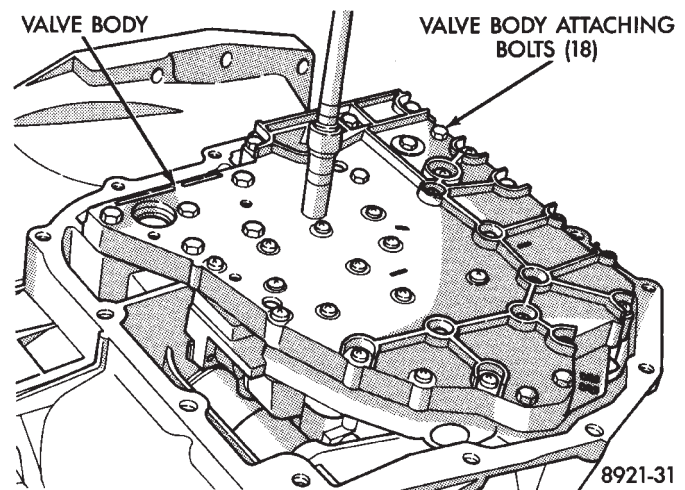

Fig. 4 Valve Body Attaching Bolts

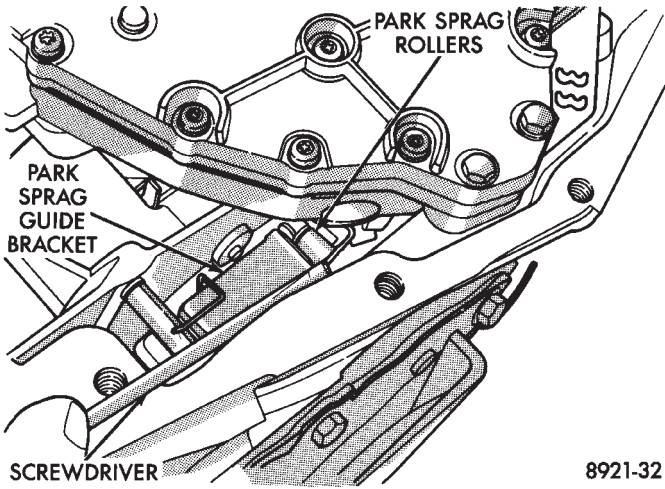

Fig. 5 Push Park Rod Rollers from Guide Bracket

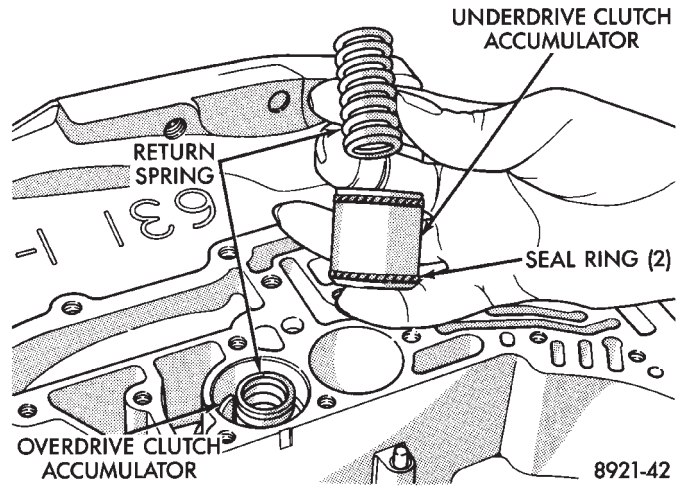

Fig. 8 Accumulators

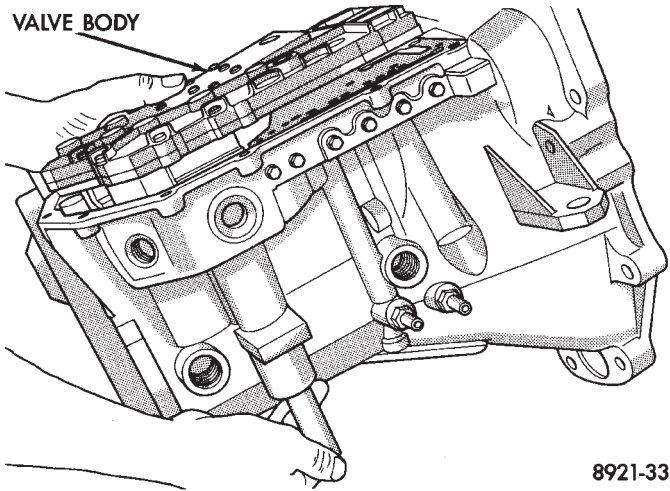

Fig. 6 Remove or Install Valve Body

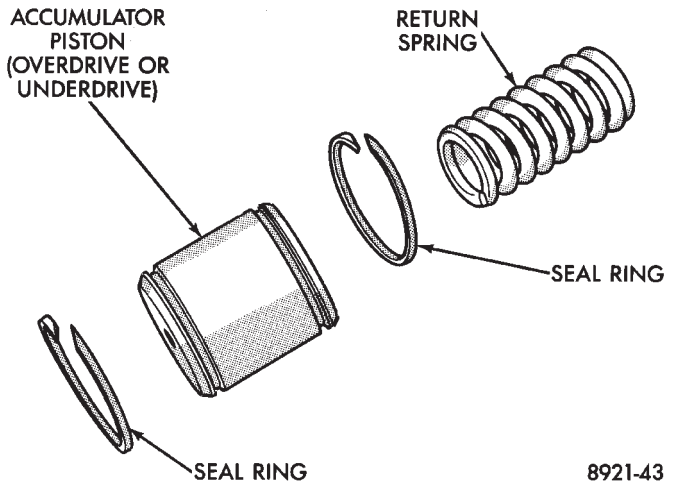

Fig. 9 Accumulator

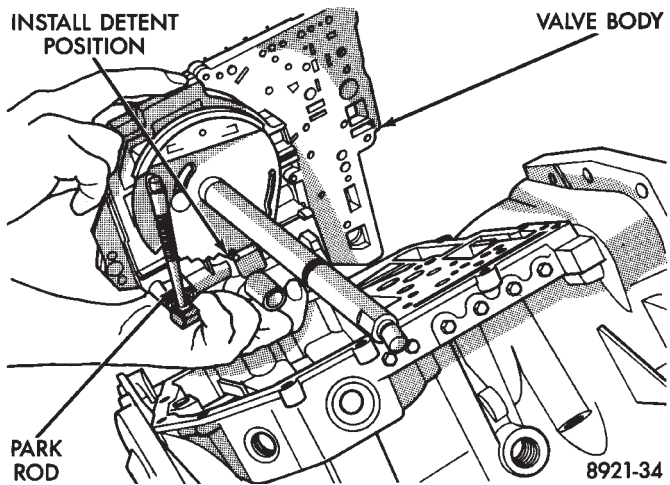

Fig. 7 Valve Body Removed

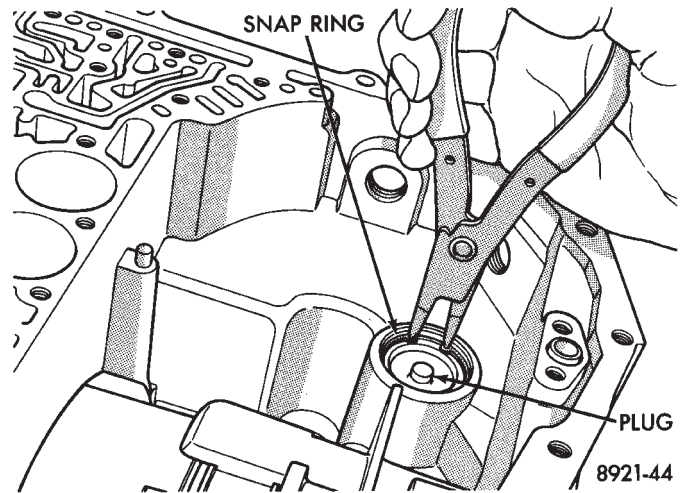

Fig. 10 Low/Reverse Accumulator Snap Ring

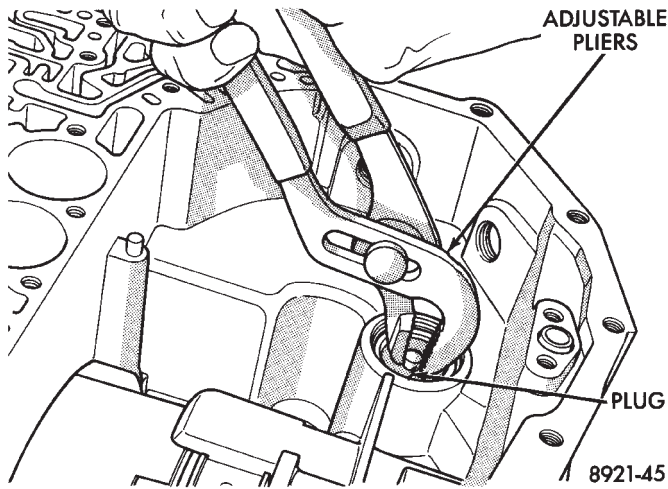

Fig. 11 Low/Reverse Accumulator Plug (Cover)

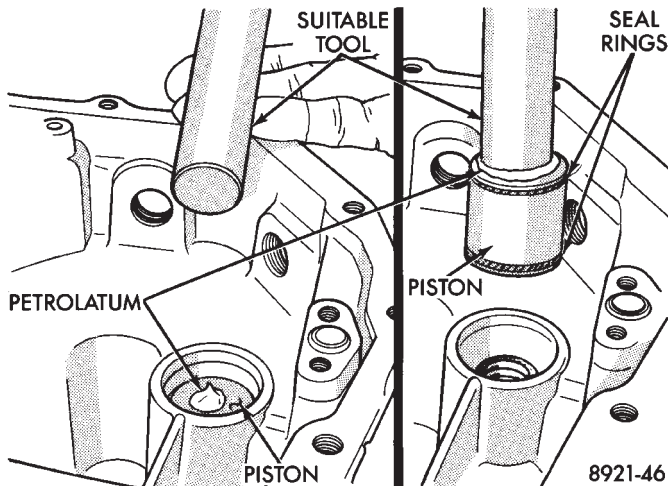

Fig. 12 Low/Reverse Accumulator Piston

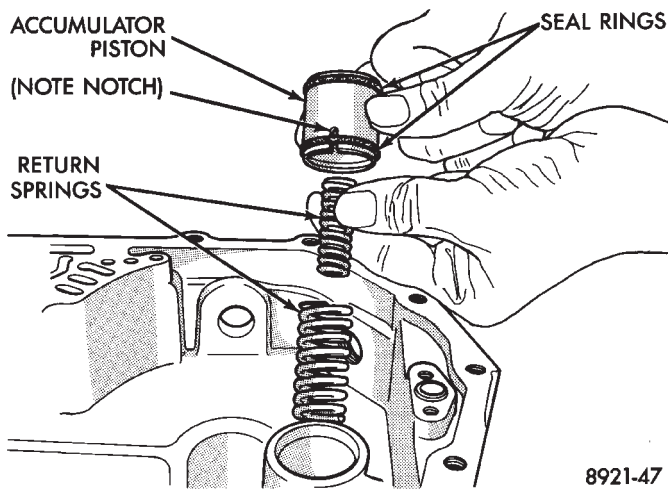

Fig. 13 Low/Reverse Accumulator

Tag all clutch pack assemblies, as they are removed, for reassembly identification.

CAUTION: Do not intermix clutch discs or plates as the unit might then fail.

Measuring input shaft end play before disassembly will usually indicate when a #4 thrust plate change is required, (except when major parts are replaced). The #4 thrust plate is located behind the overdrive clutch hub.

Attach a dial indicator to transaxle bell housing with its plunger seated against end of input shaft (Fig. 14). Move input shaft in and out to obtain end play

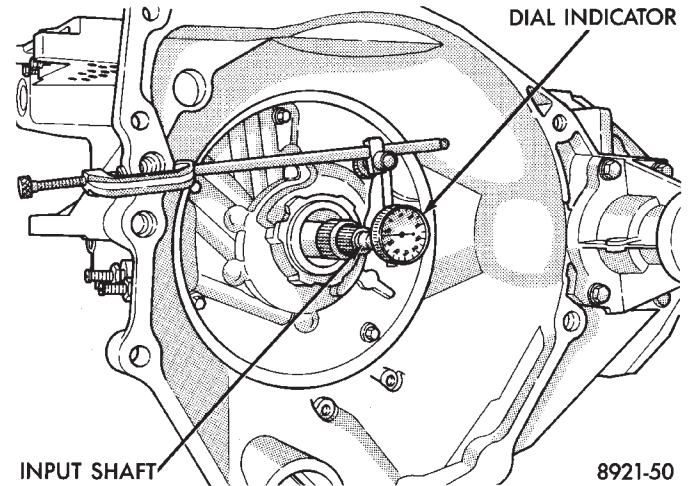

Fig. 14 Measure Input Shaft End Play

reading. End play specifications are .13 to .64 mm (.005 to .025 inch).

Record indicator reading for reference when reassembling the transaxle.

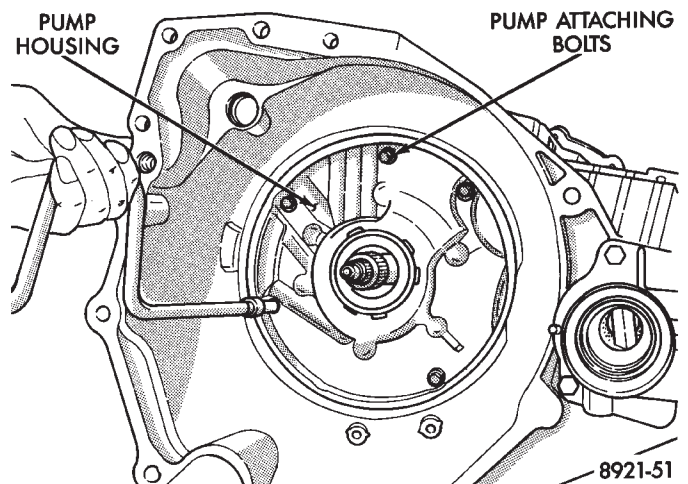

Fig. 15 Pump Attaching Bolts

CAUTION: Be sure input speed sensor is removed before removing oil pump.

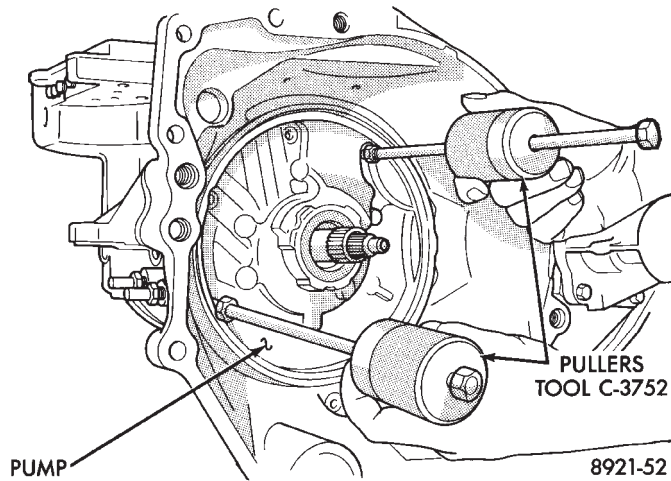

Fig. 16 Install Tool C-3752

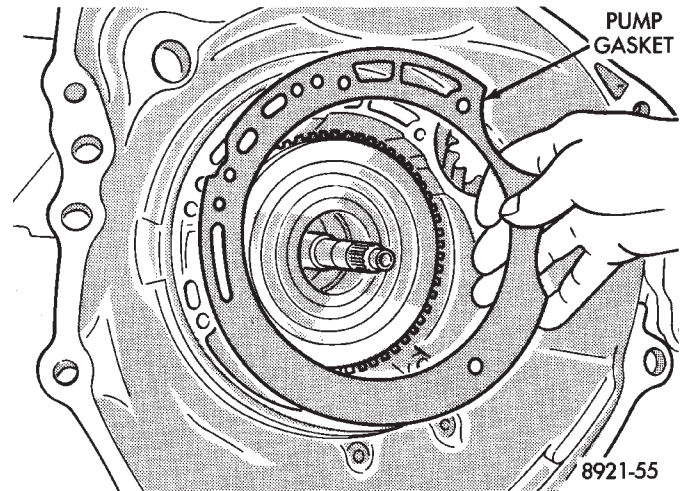

Fig. 19 Oil Pump Gasket

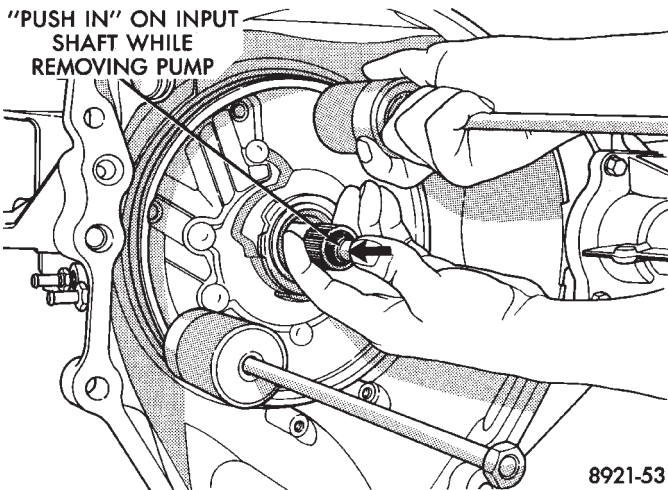

Fig. 17 Remove Oil Pump

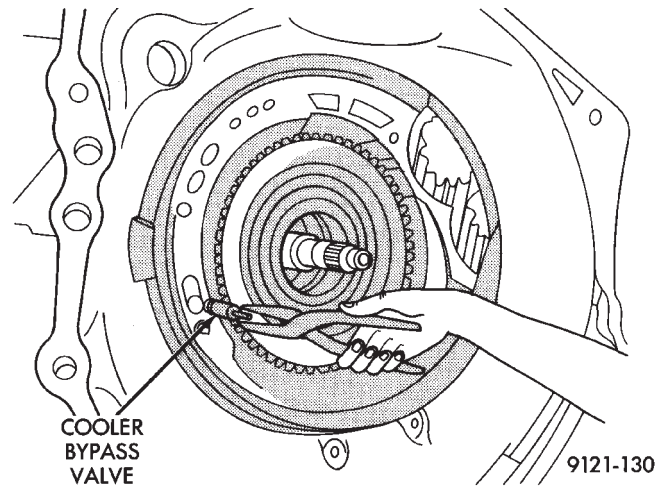

Fig. 20 Remove Cooler Bypass Valve

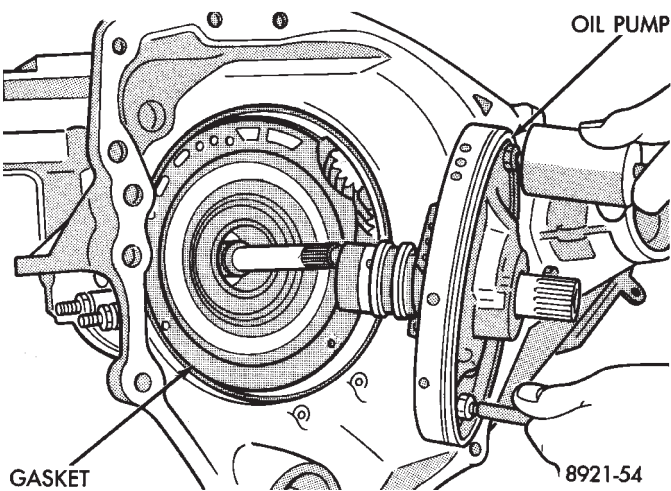

Fig. 18 Oil Pump Removed

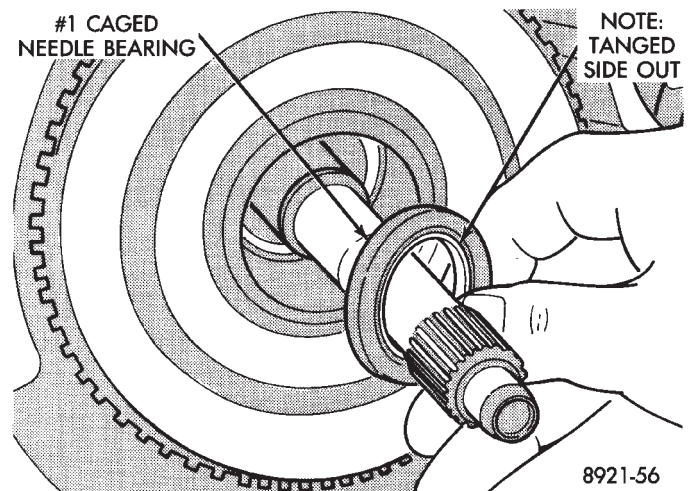

Fig. 21 No. 1 Caged Needle Bearing

CAUTION: The cooler bypass valve must be replaced if a transaxle failure has occurred. Do not reuse old valve or attempt to clean old valve. When installing bypass valve, insert with O-ring end towards rear of case.

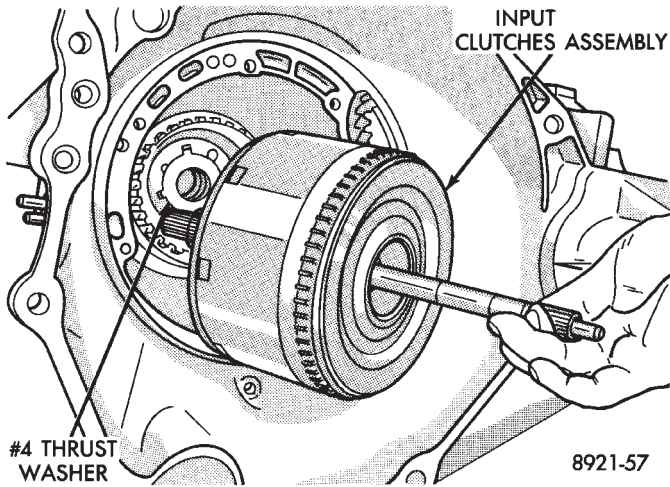

Fig. 22 Input Clutches Assembly

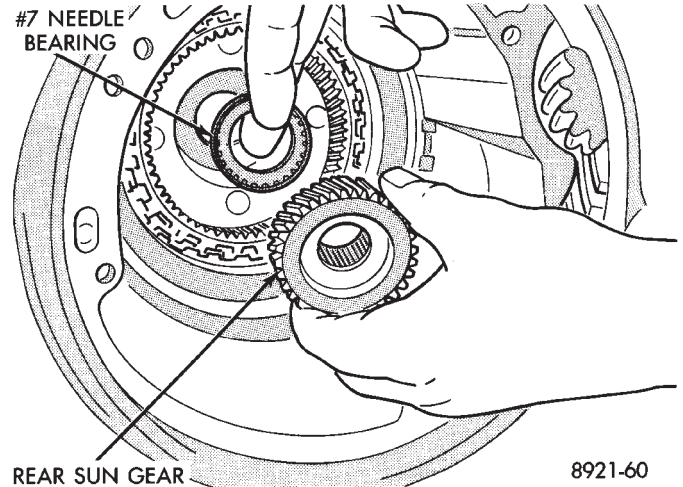

Fig. 25 Rear Sun Gear

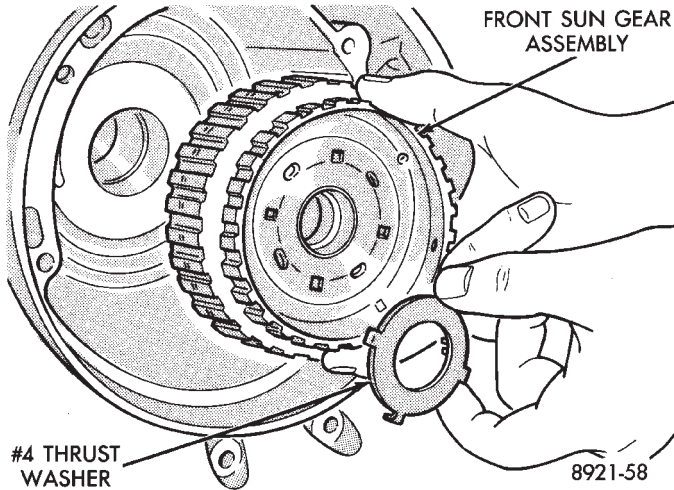

Fig. 23 Front Sun Gear Assembly

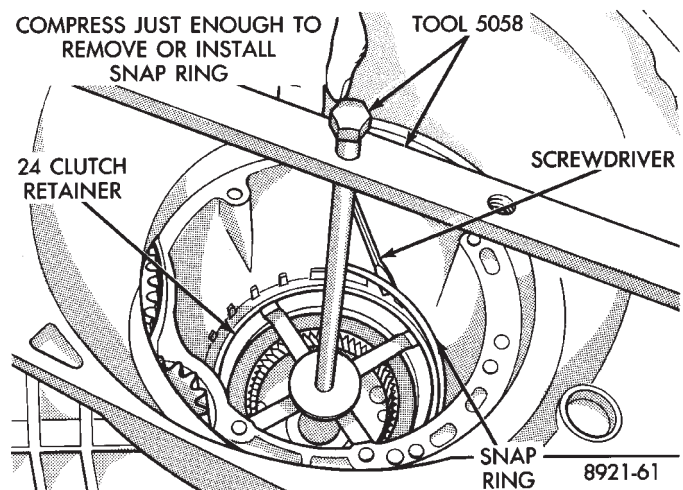

Fig. 26 2/4 Clutch Retainer Snap Ring

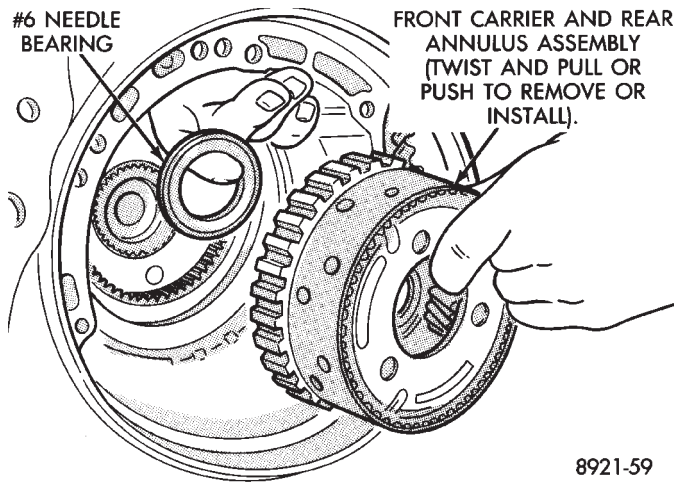

Fig. 24 Front Carrier and Rear Annulus Assembly

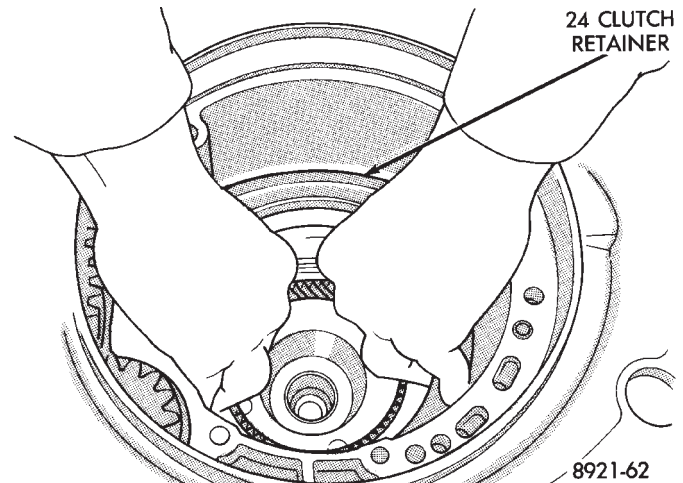

Fig. 27 Remove 2/4 Clutch Retainer

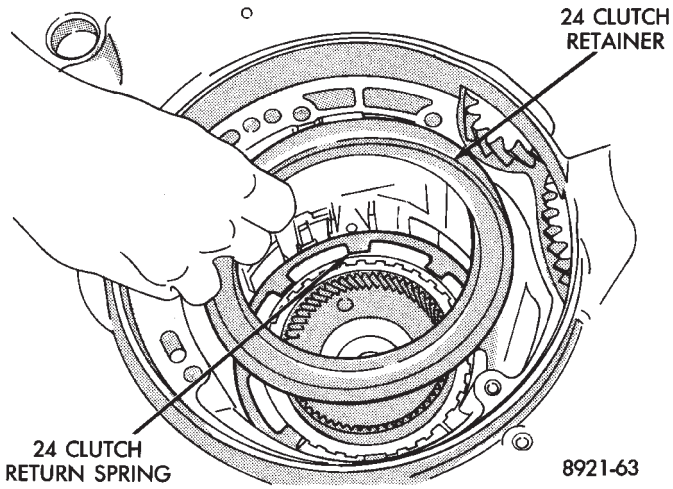

Fig. 28 2/4 Clutch Retainer

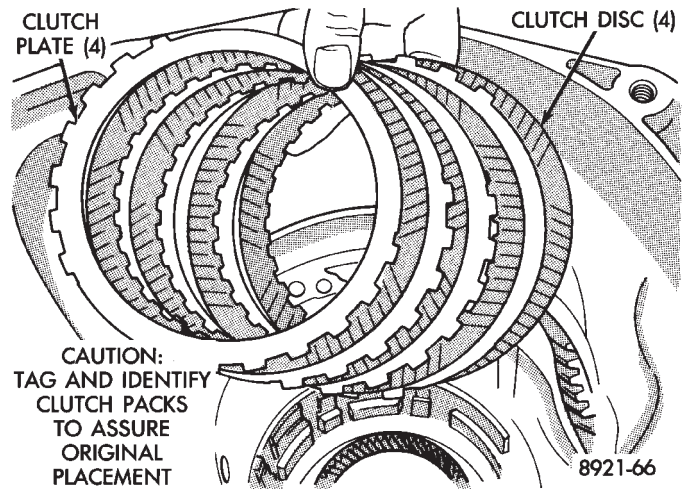

Fig. 31 2/4 Clutch Pack

Tag 2/4 clutch pack for reassembly identification.

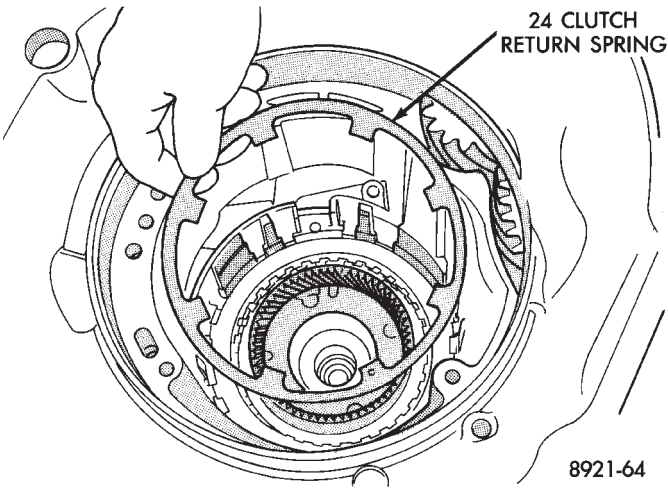

Fig. 29 2/4 Clutch Return Spring

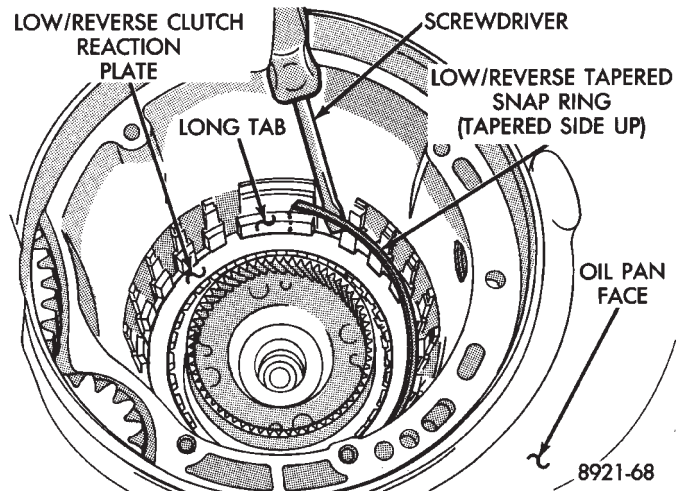

Fig. 32 Tapered Snap Ring

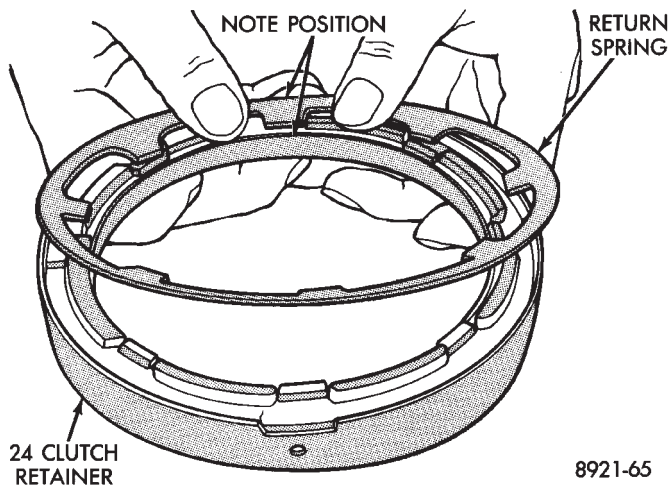

Fig. 30 2/4 Retainer and Spring Indexed

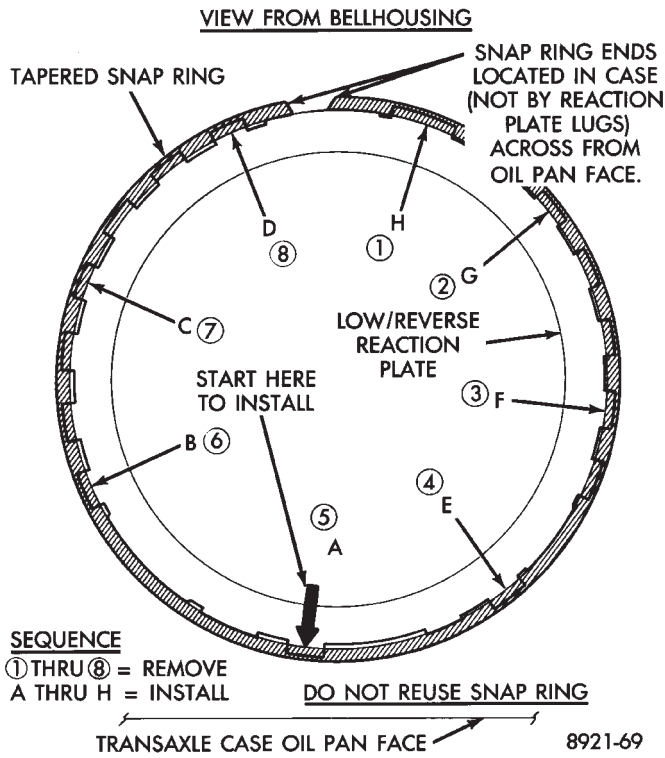

Fig. 33 Tapered Snap Ring Instructions

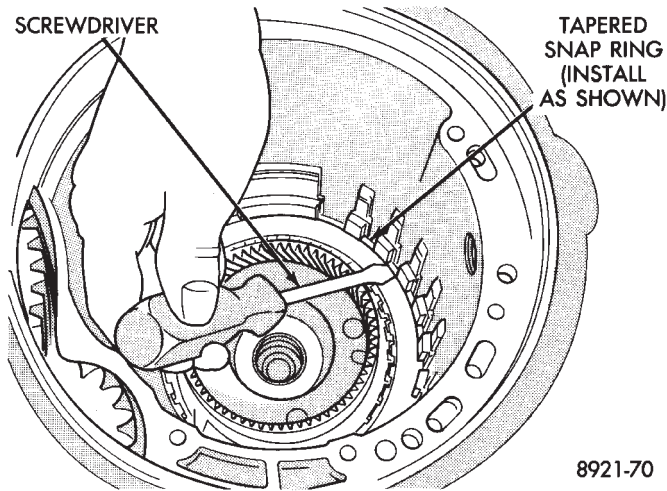

Fig. 34 Snap Ring Installed

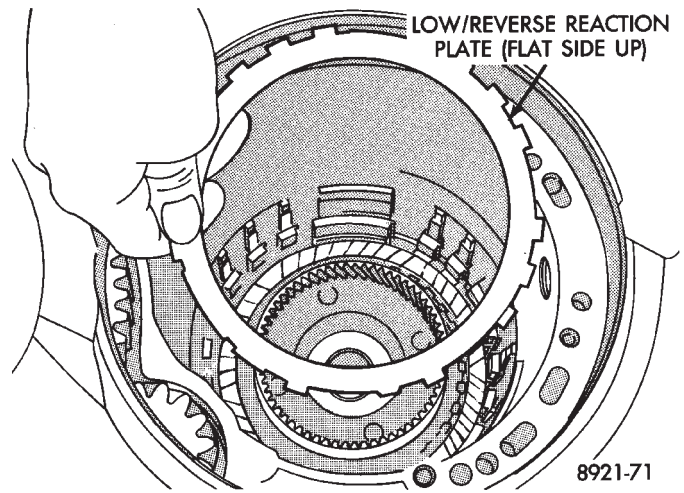

Fig. 35 Low/Reverse Reaction Plate

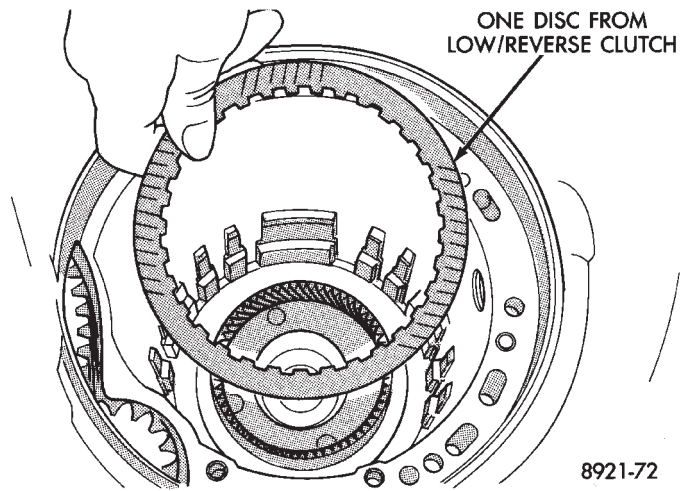

Fig. 36 Remove One Disc

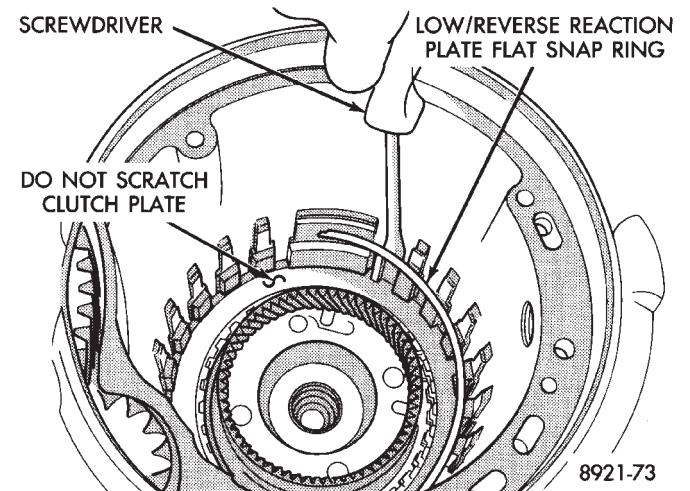

Fig. 37 Low/Reverse Reaction Plate Snap Ring

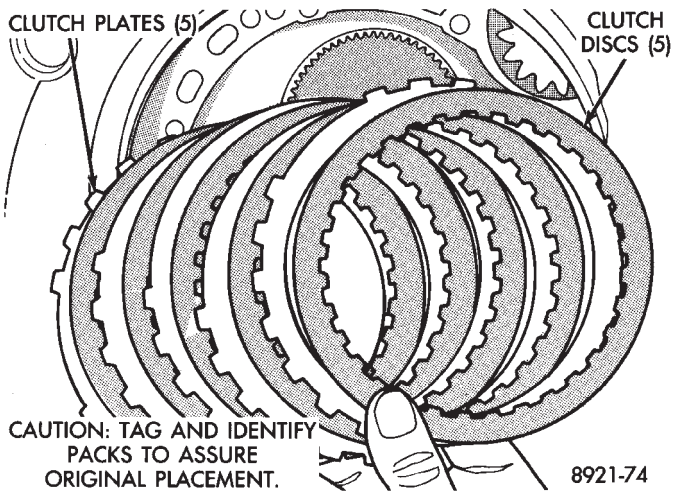

Fig. 38 Low/Reverse Clutch Pack

Tag low/reverse clutch pack for reassembly identification.

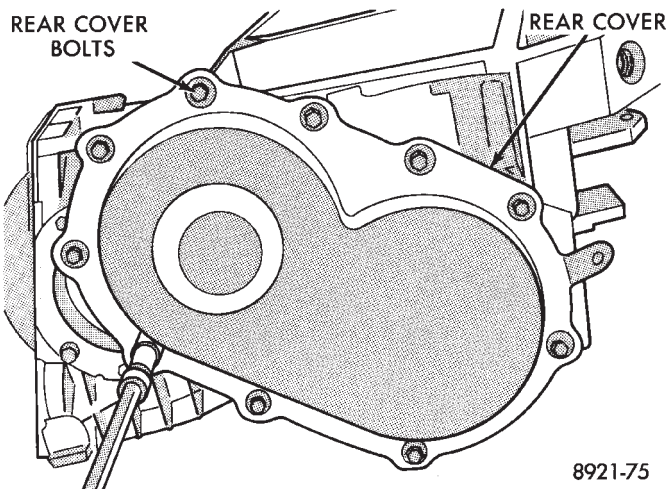

Fig. 39 Rear Cover Bolts

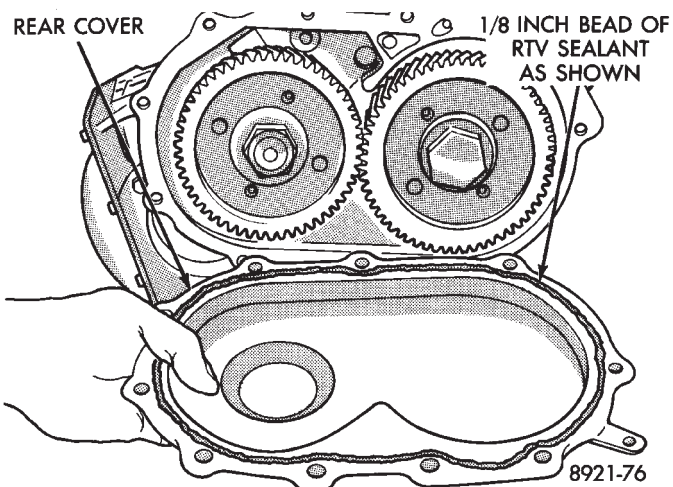

Fig. 40 Rear Cover

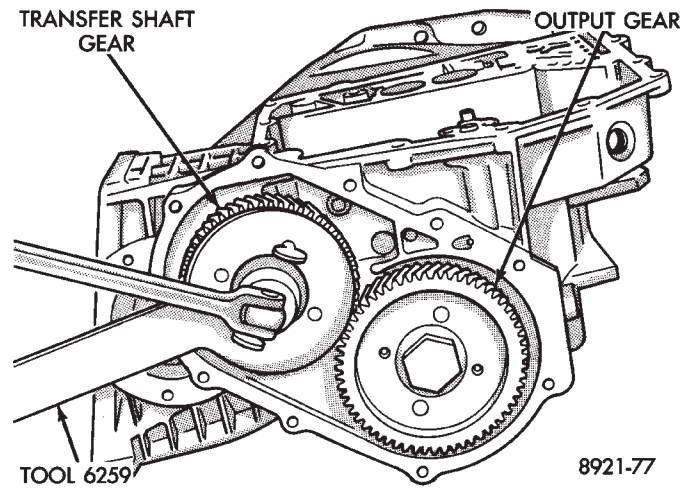

Fig. 41 Remove Transfer Shaft Gear Nut

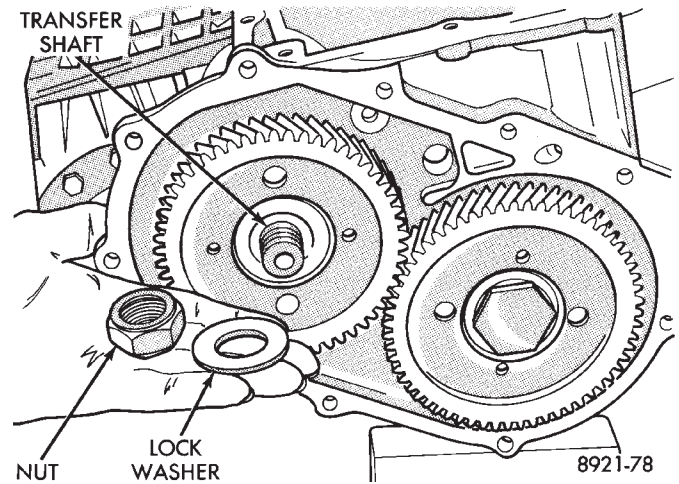

Fig. 42 Transfer Shaft Gear Nut and Washer

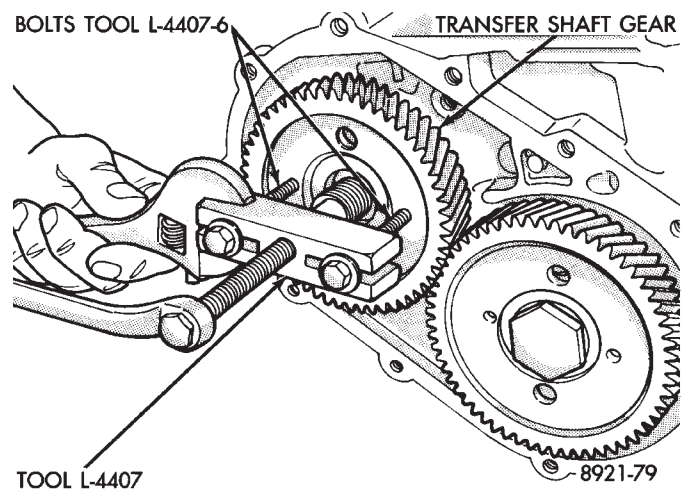

Fig. 43 Remove Transfer Shaft Gear

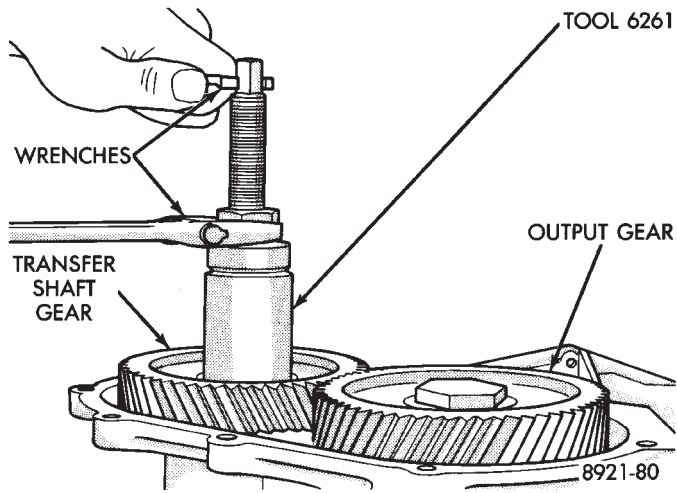

Fig. 44 Install Transfer Shaft Gear

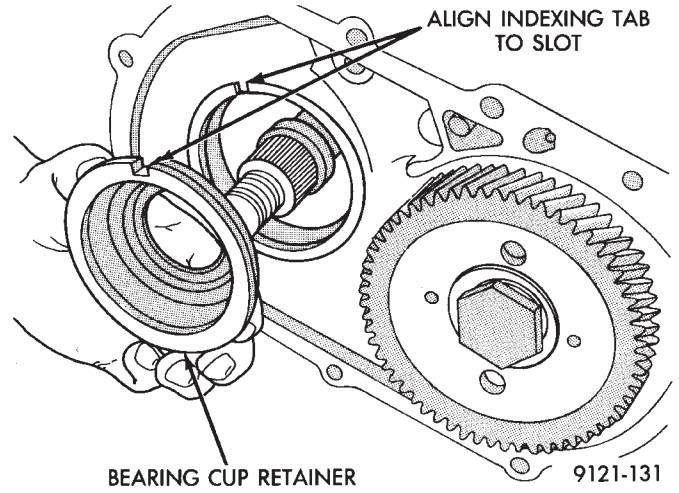

Fig. 47 Bearing Cup Retainer

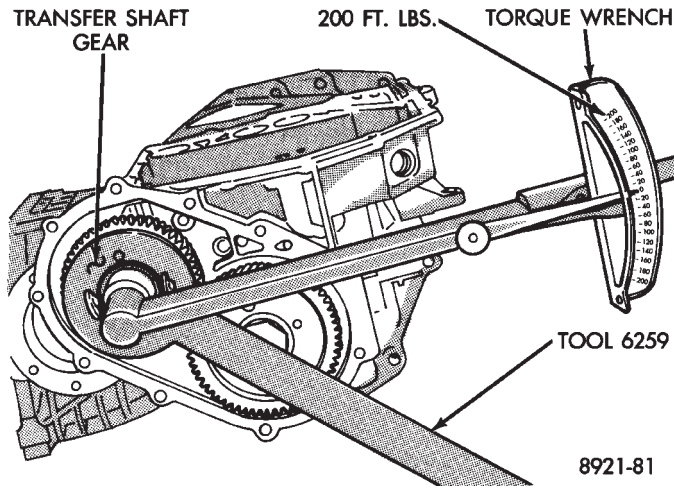

Fig. 45 Tighten Nut to 271 Nm (200 Ft. Lbs.)

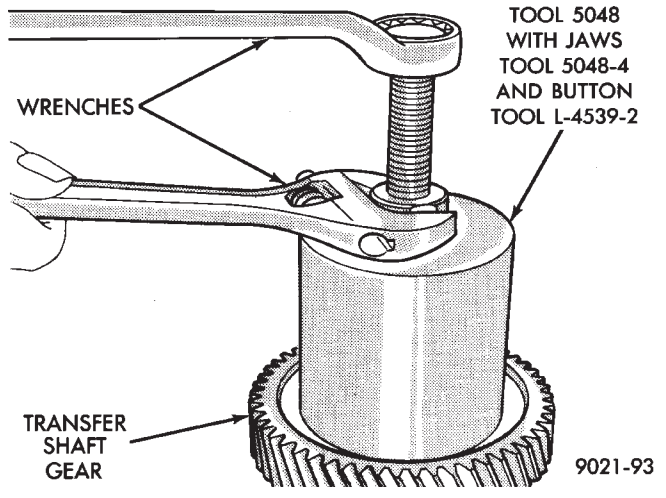

Fig. 48 Remove Transfer Shaft Bearing Cone

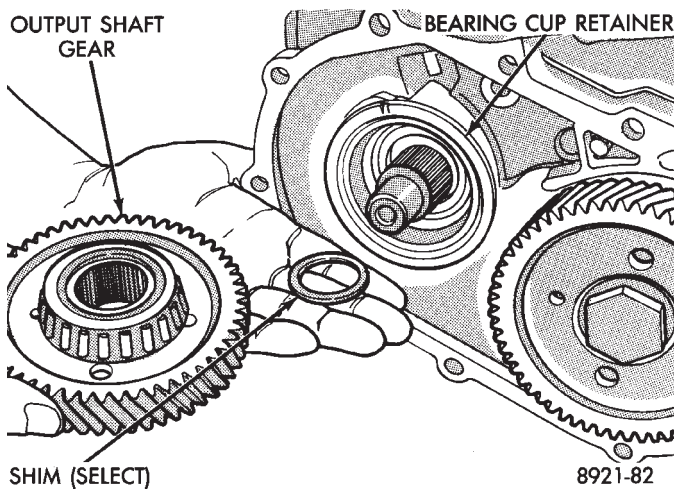

Fig. 46 Transfer Shaft Gear and (Select) Shim

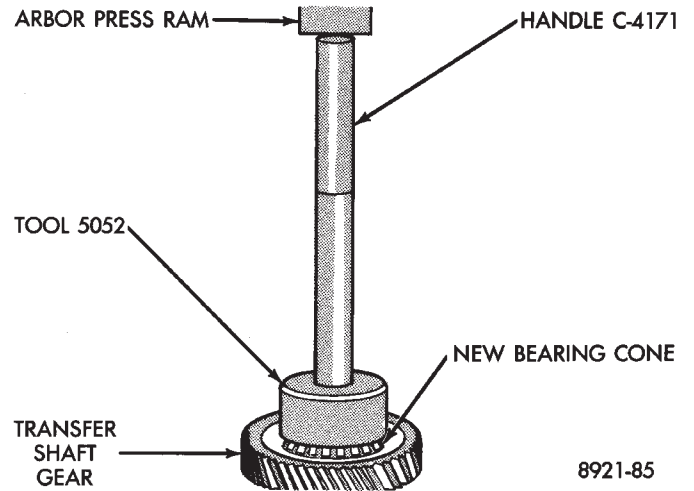

Fig. 49 Install Transfer Shaft Bearing Cone

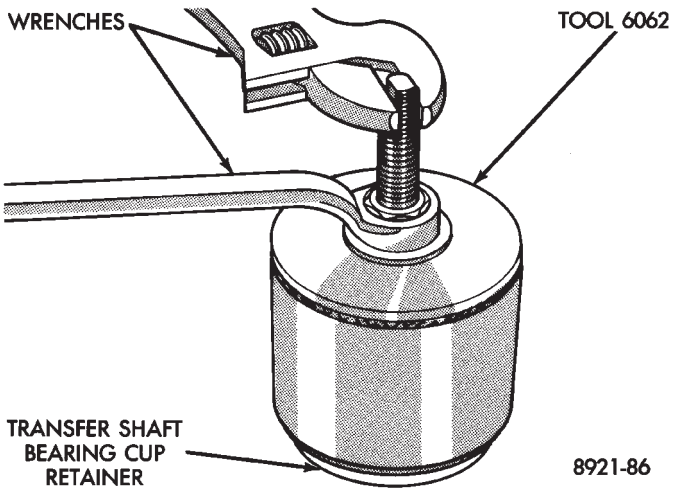

Fig. 50 Remove Transfer Shaft Bearing Cup

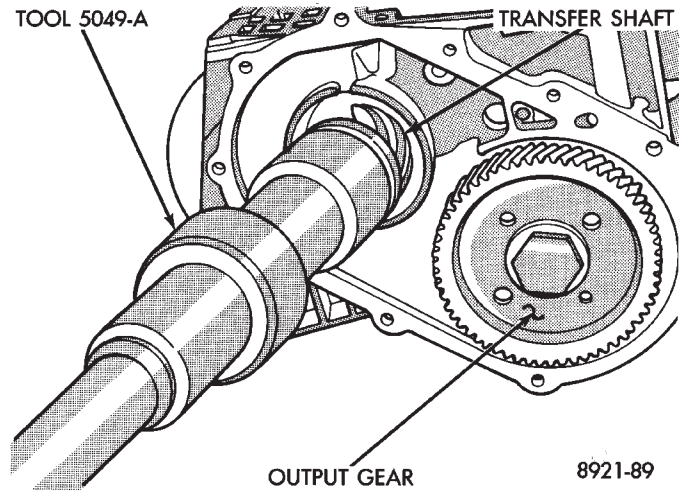

Fig. 53 Transfer Shaft

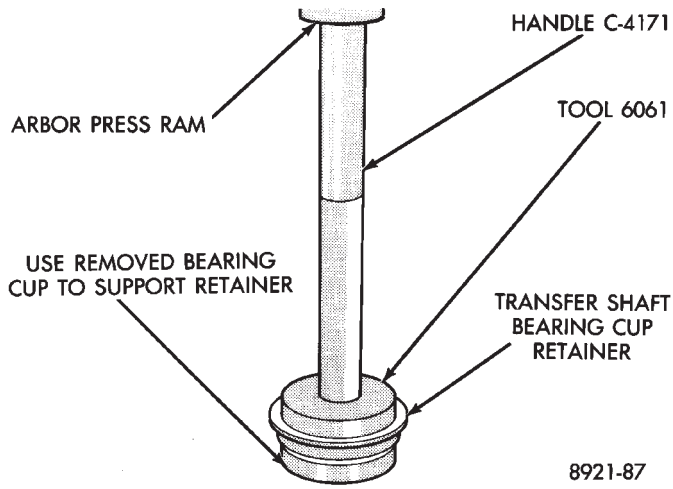

Fig. 51 Install New Bearing Cup

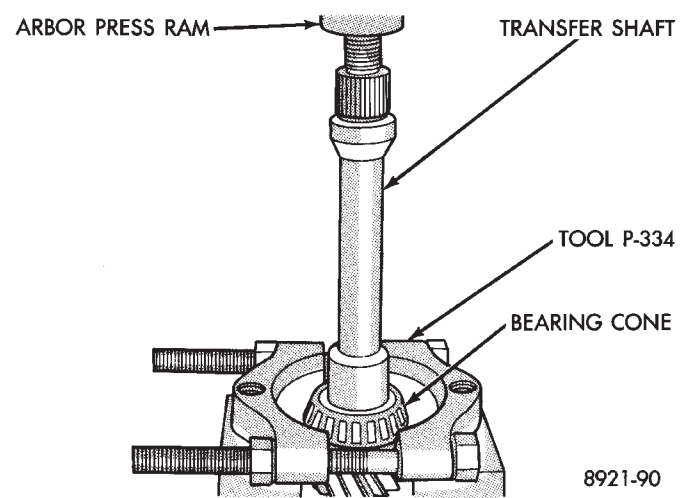

Fig. 54 Remove Transfer Shaft Bearing Cone

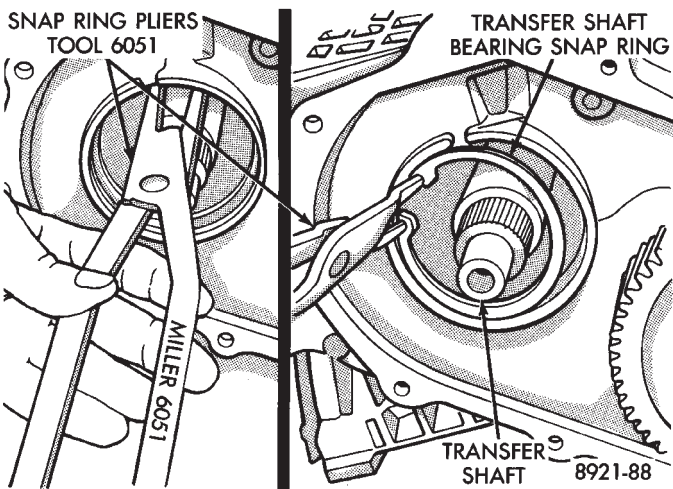

Fig. 52 Transfer Shaft Bearing Snap Ring

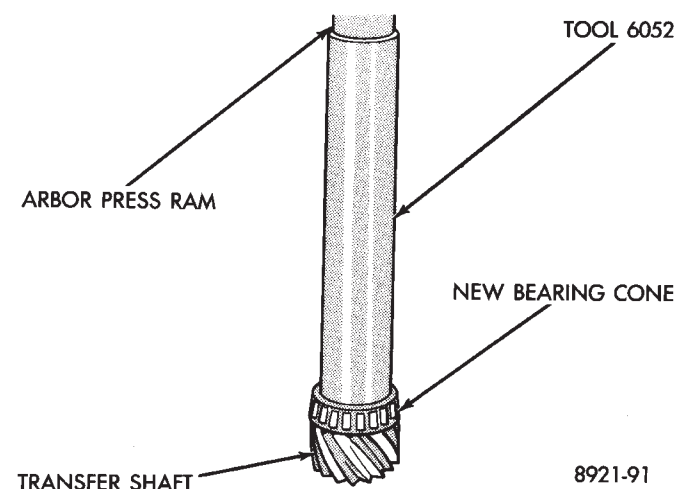

Fig. 55 Install Bearing Cone

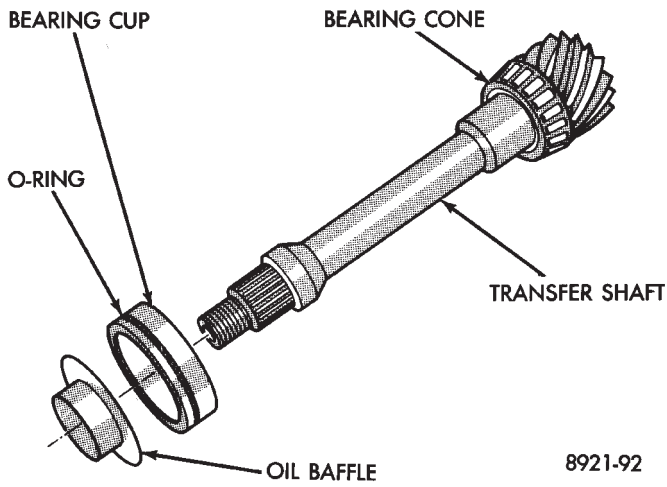

Fig. 56 Bearing Cup Removed

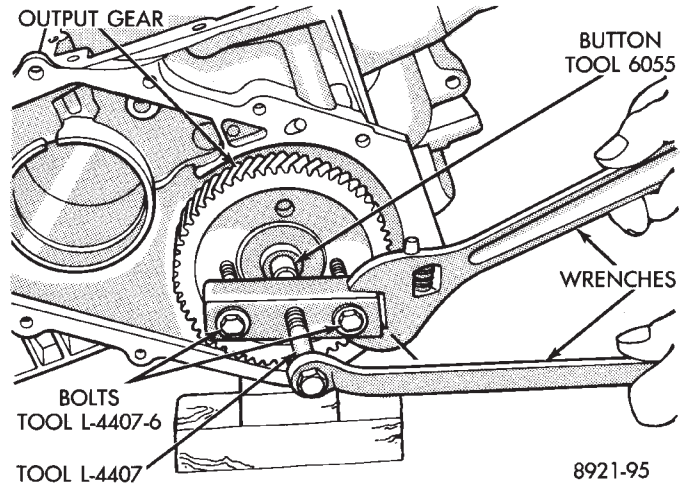

Fig. 59 Remove Output Gear

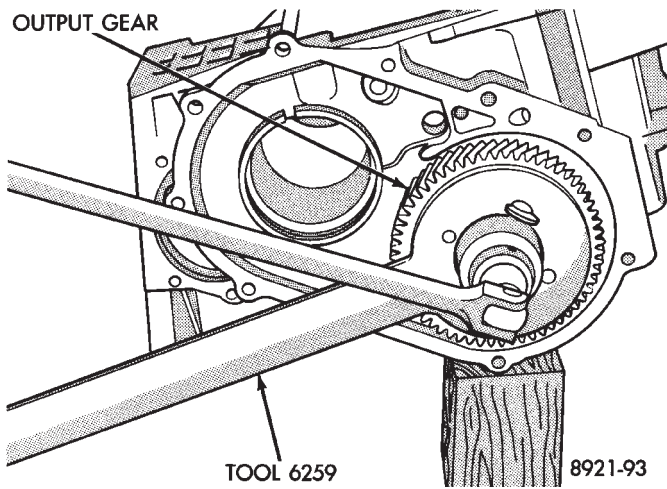

Fig. 57 Remove Output Gear Bolt

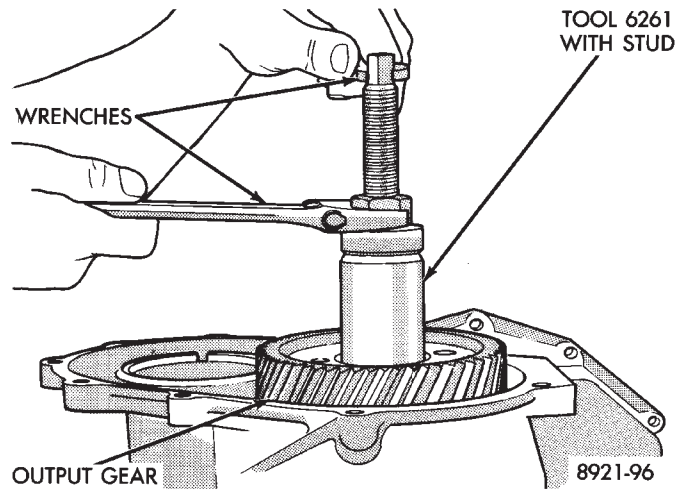

Fig. 60 Install Output Gear

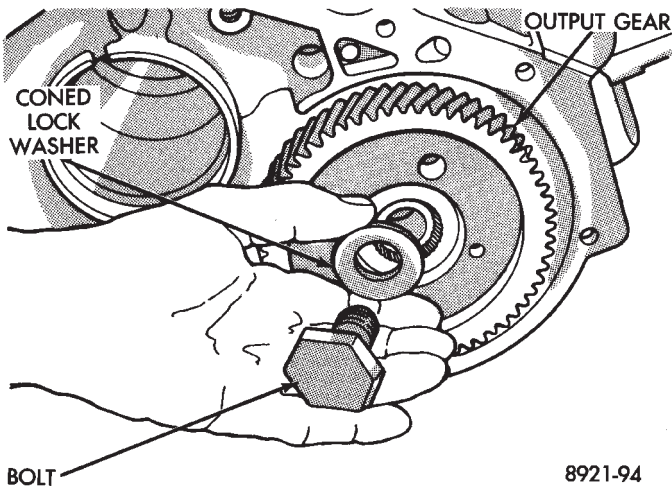

Fig. 58 Output Gear Bolt and Washer

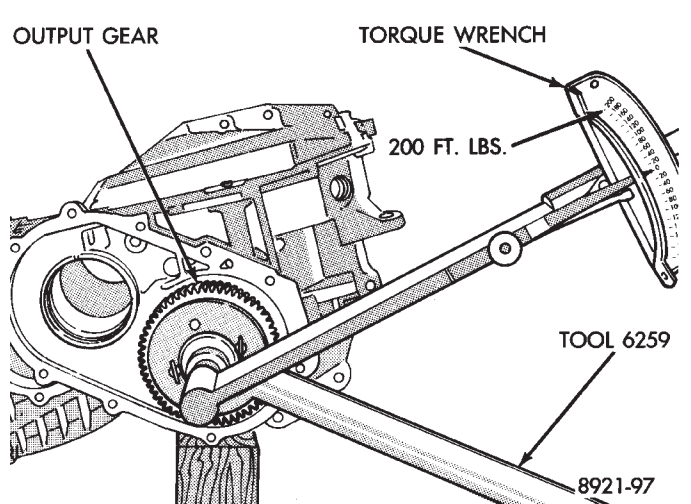

Fig. 61 Tighten Output Gear to 271 N•m (200 Ft. Lbs.)

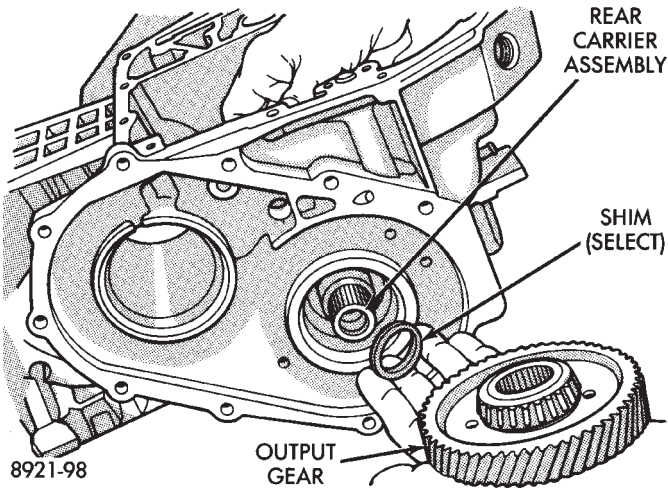

Fig. 62 Output Gear and (Select) Shim

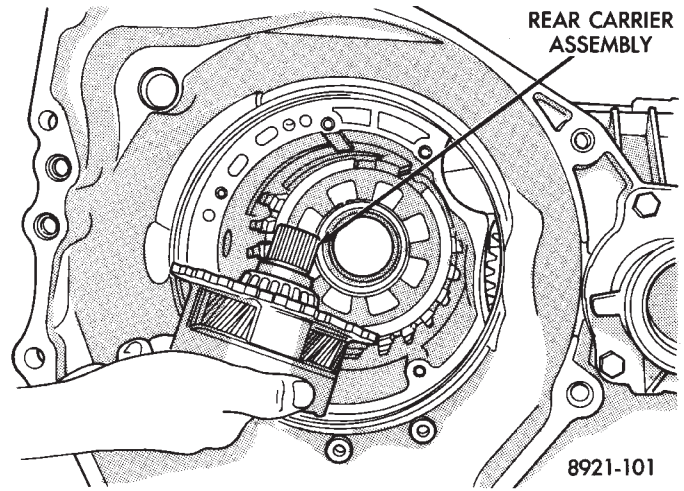

Fig. 65 Rear Carrier Assembly

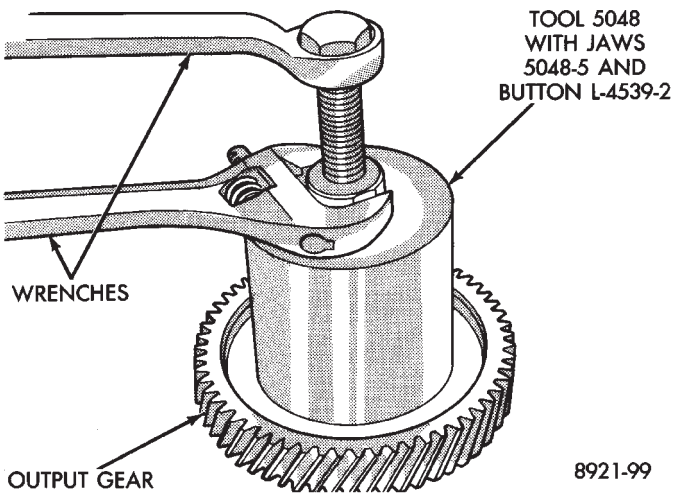

Fig. 63 Remove Bearing Cone

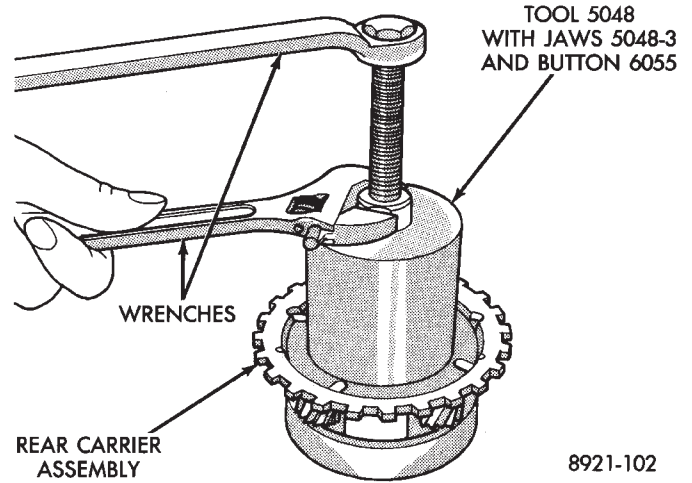

Fig. 66 Remove Rear Carrier Bearing Cone

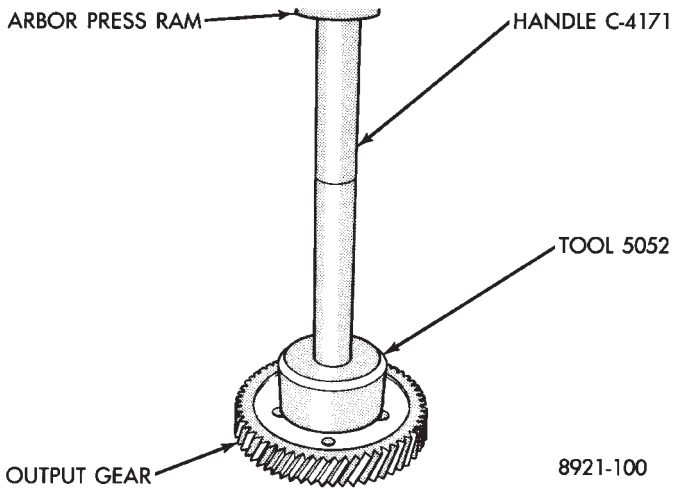

Fig. 64 Install New Bearing Cone

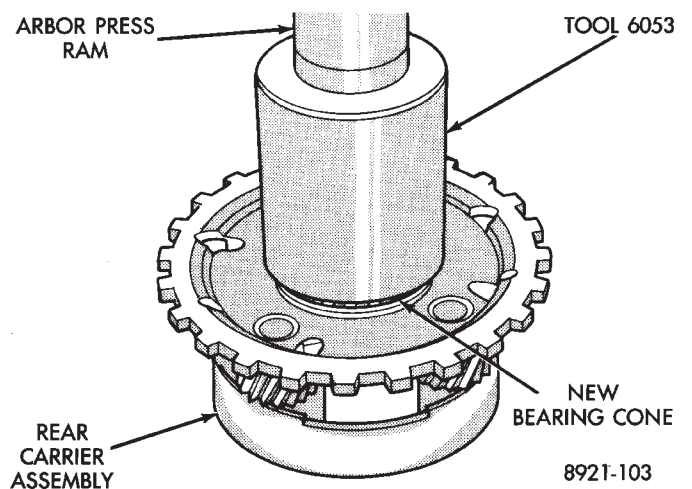

Fig. 67 Install Rear Carrier Bearing Cone

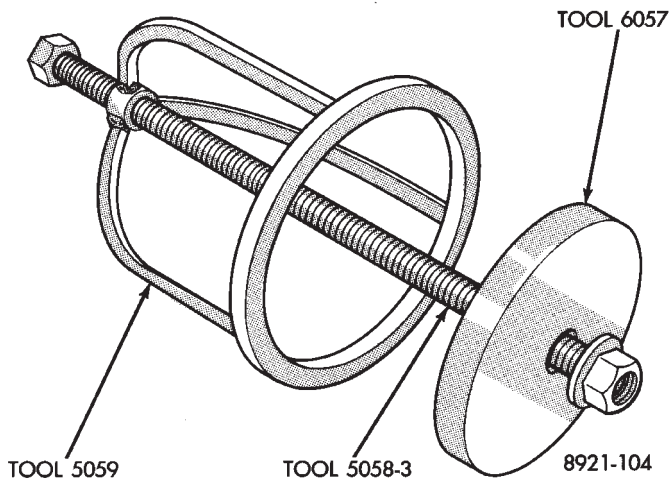

Fig. 68 Low/Reverse Spring Compressor Tool

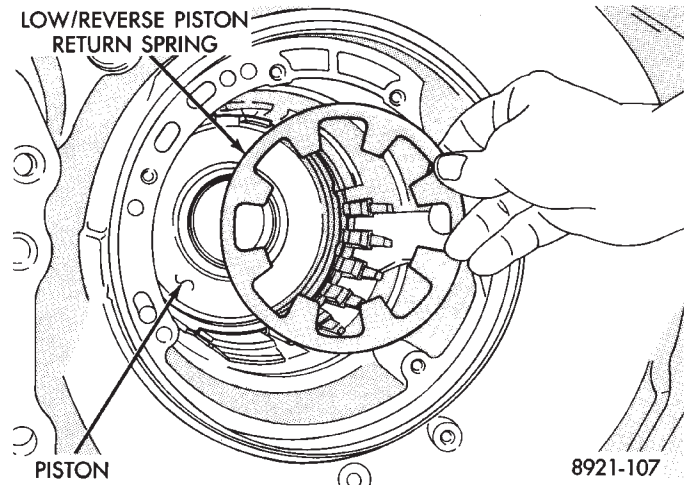

Fig. 71 Low/Reverse Piston Return Spring

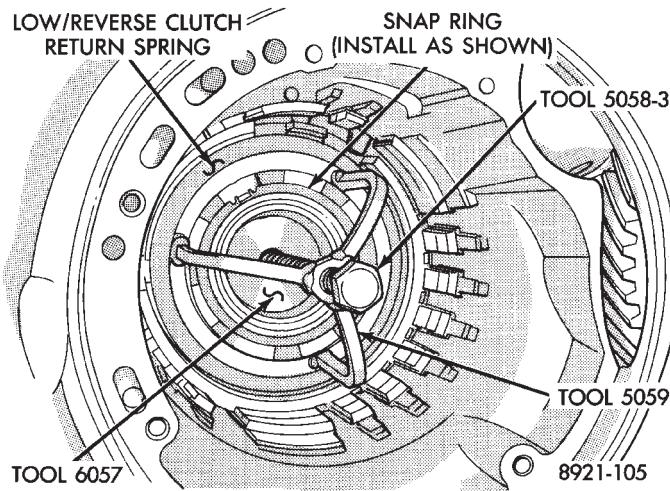

Fig. 69 Compressor Tool in Use

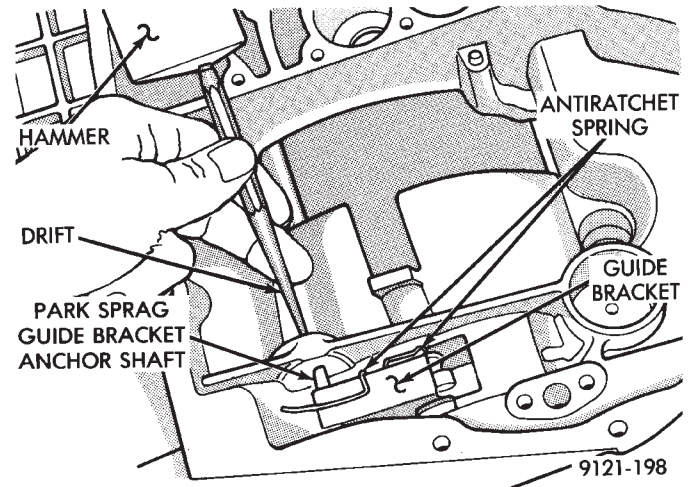

Fig. 72 Drive Out Anchor Shaft

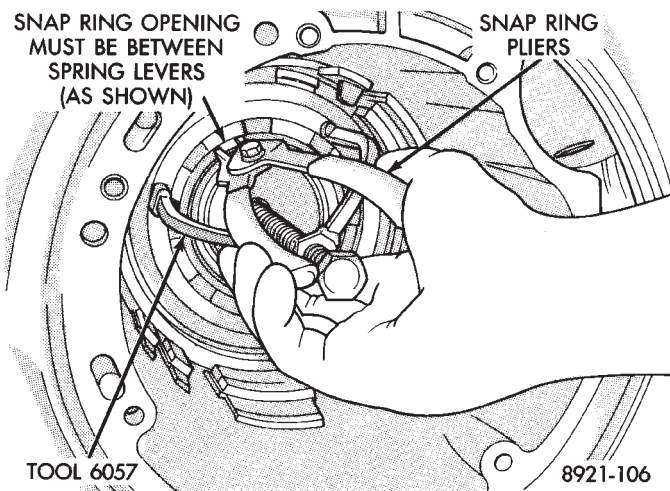

Fig. 70 Remove or Install Snap Ring

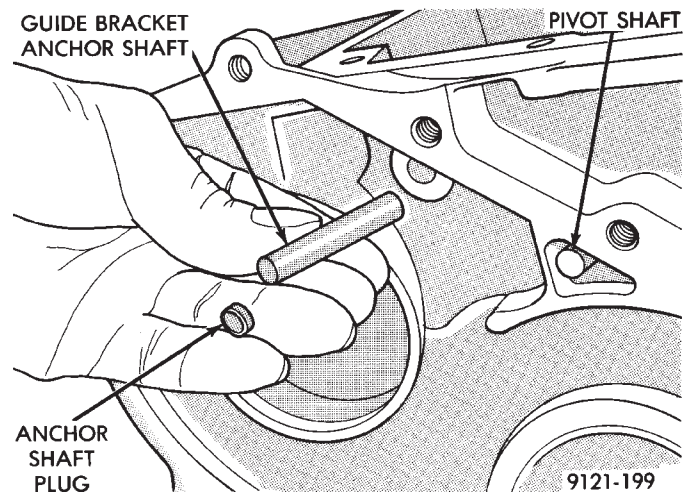

Fig. 73 Anchor Shaft and Plug

CAUTION: When installing, be sure guide bracket and split sleeve touch the rear of the transaxle case.

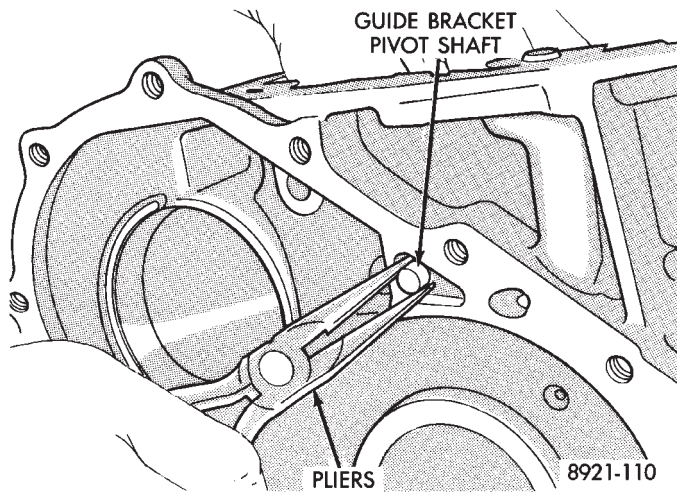

Fig. 74 Guide Bracket Pivot Shaft

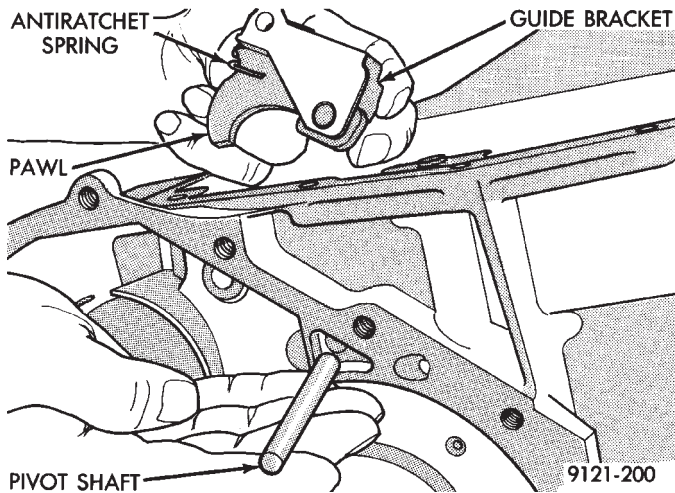

Fig. 75 Pivot Shaft and Guide Bracket

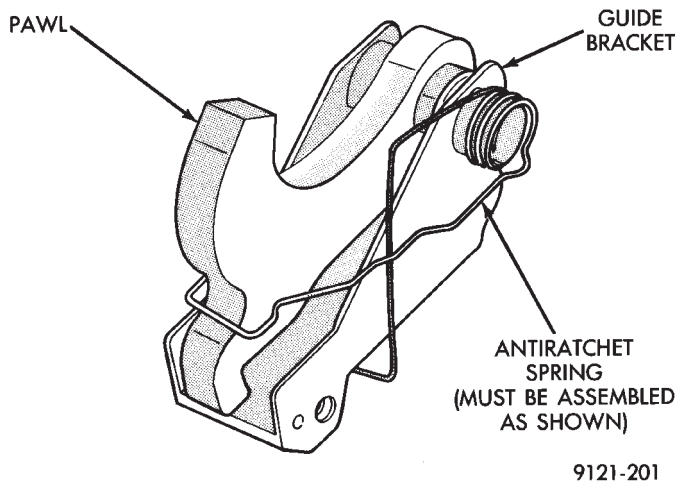

Fig. 76 Guide Bracket Assembled

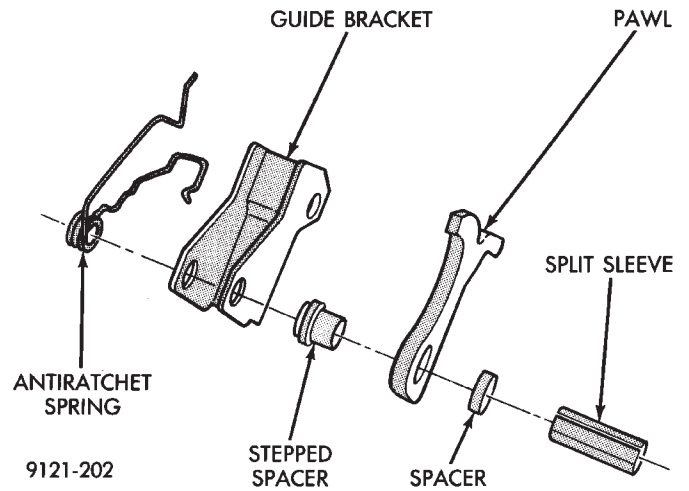

Fig. 77 Guide Bracket Disassembled

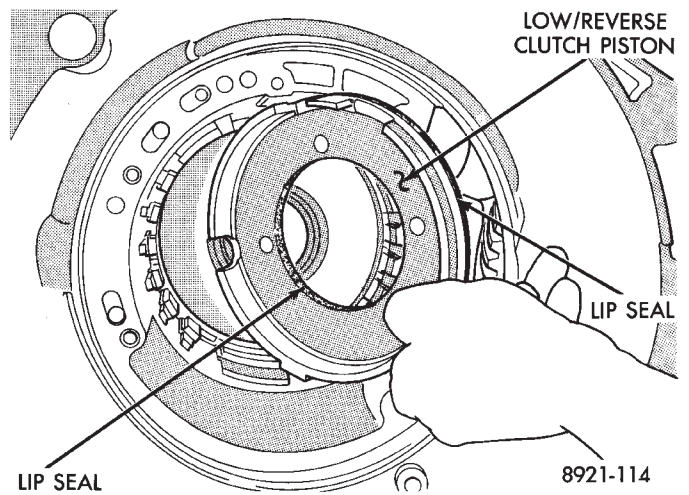

Fig. 78 Low/Reverse Clutch Piston

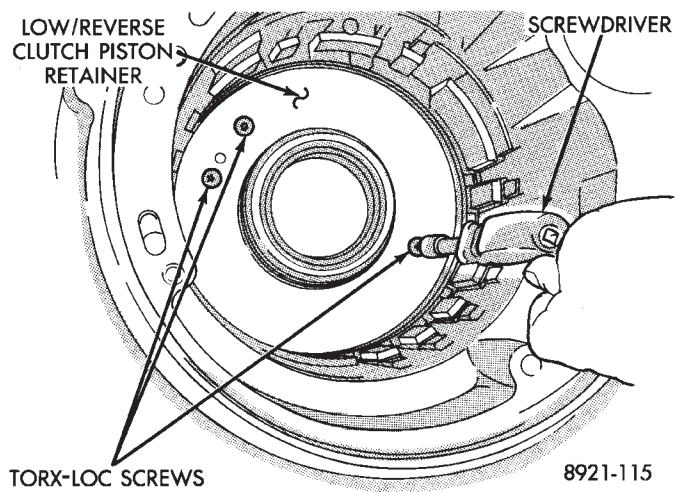

Fig. 79 Piston Retainer Attaching Screws

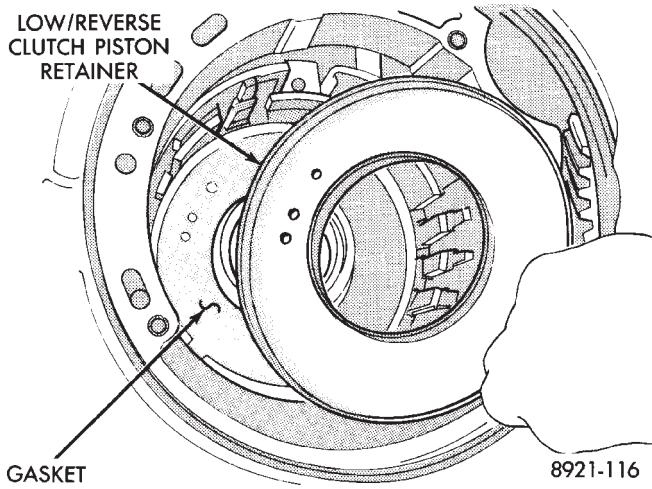

Fig. 80 Piston Retainer

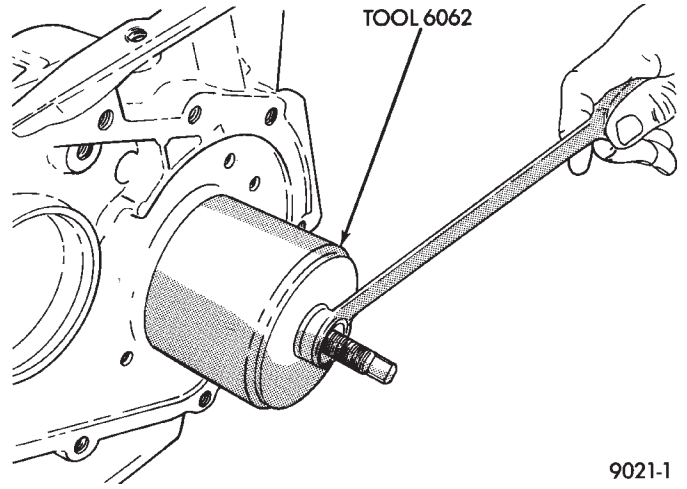

Fig. 83 Remove Output Bearing Outer Cup

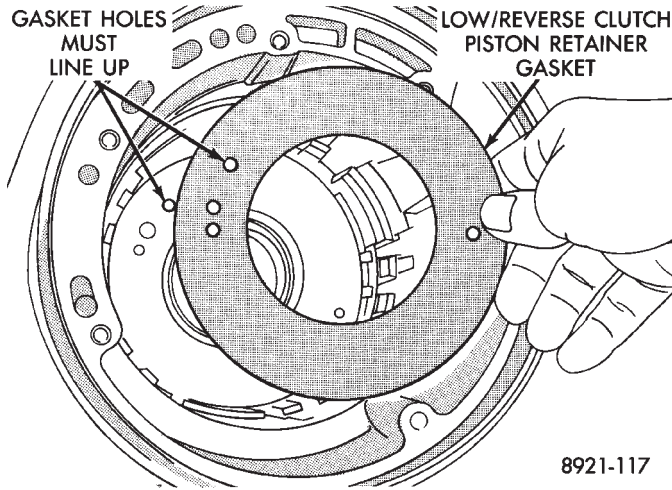

Fig. 81 Piston Retainer Gasket

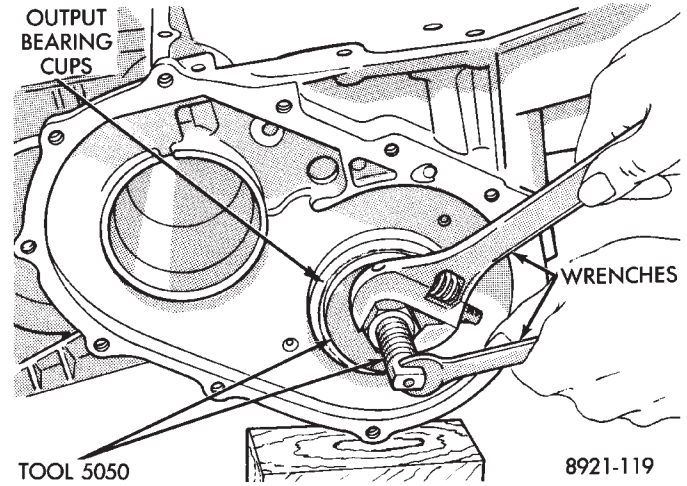

Fig. 84 Install Both Output Bearing Cups

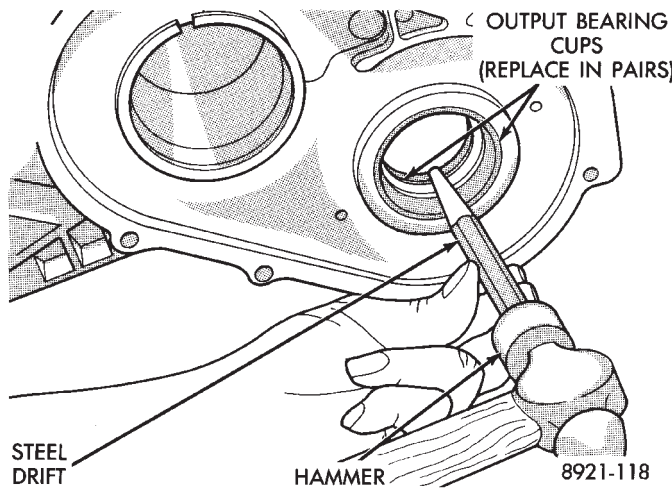

Fig. 82 Remove Output Bearing Inner Cup
CAUTION: Drift bearing cup all the way around.

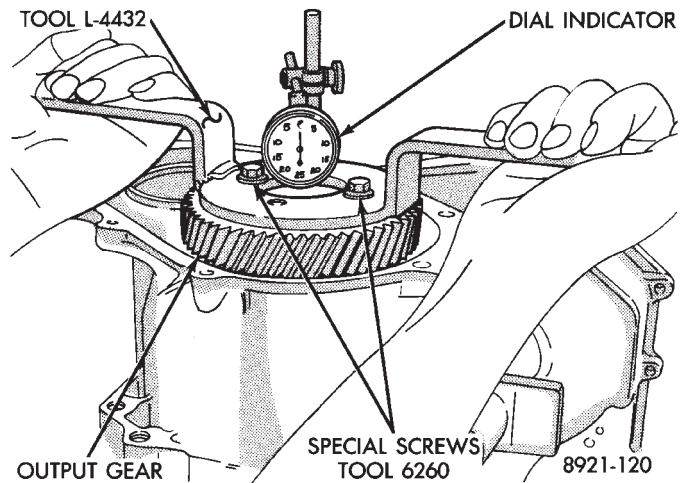

Fig. 85 Checking Output Gear Bearings End Play

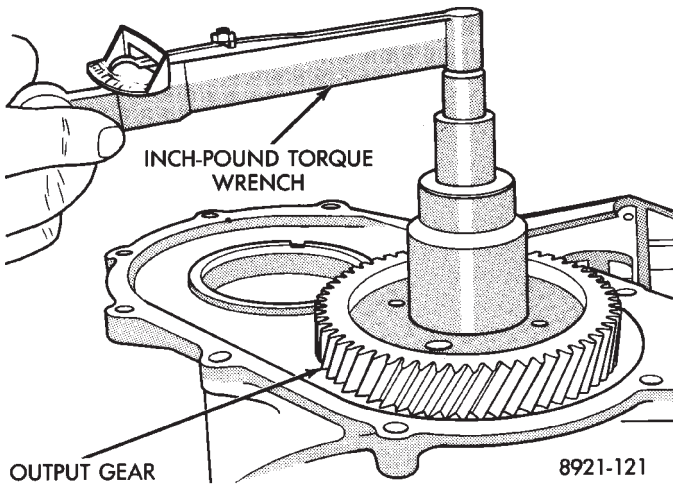

Fig. 86 Checking Output Gear Bearings Turning Torque

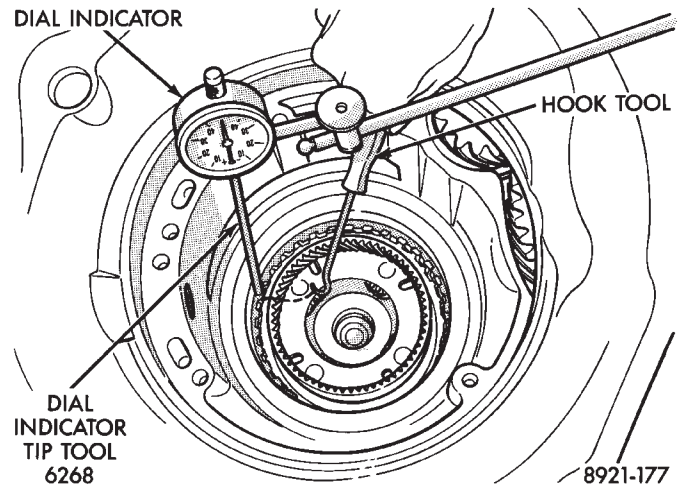

Fig. 88 Check 2/4 Clutch Clearance

tions, the clutch is not assembled properly. **There is no adjustment for the 2/4 clutch clearance.**

DETERMINING No. 4 THRUST PLATE THICKNESS (Input Shaft End Play)

To determine the proper thickness of the No. 4 thrust plate, select the thinnest No. 4 thrust plate. Using petrolatum to hold thrust plate in position, install input clutches assembly. Be sure the input clutches assembly is completely seated.

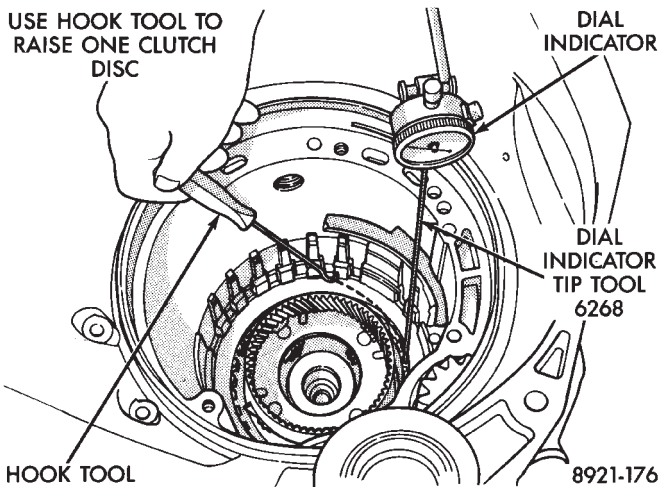

Fig. 87 Check Low/Reverse Clutch Clearance

Press down clutch pack with finger and zero dial indicator. **Low/Reverse clutch pack clearance is 1.04 to 1.65mm (.042 to .065 inch).**

Select the proper low/reverse reaction plate to achieve specifications:

LOW/REVERSE REACTION PLATE CHART

THICKNESS
6.92 mm (.273 in.)
6.66 mm (.262 in.)
6.40 mm (.252 in.)
6.14 mm (.242 in.)
5.88 mm (.232 in.)
5.62 mm (.221 in.)
5.36 mm (.211 in.)

9121-4

Press down clutch pack with finger and zero dial indicator. **The 2/4 clutch pack clearance is 0.76 to 2.64mm (.030 to .104 inch).** If not within specifica-

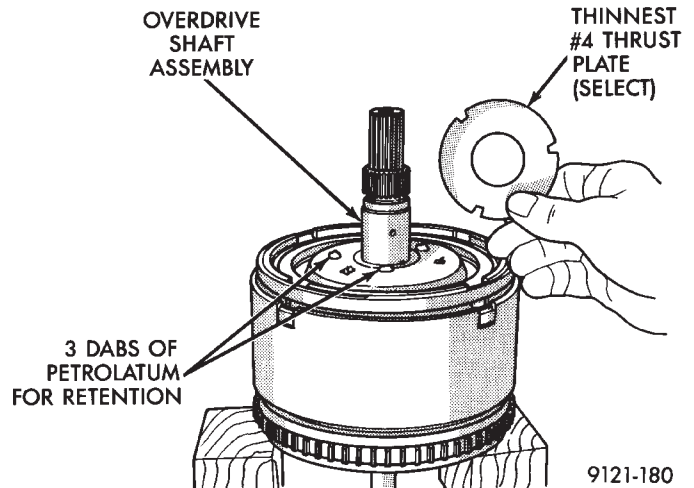
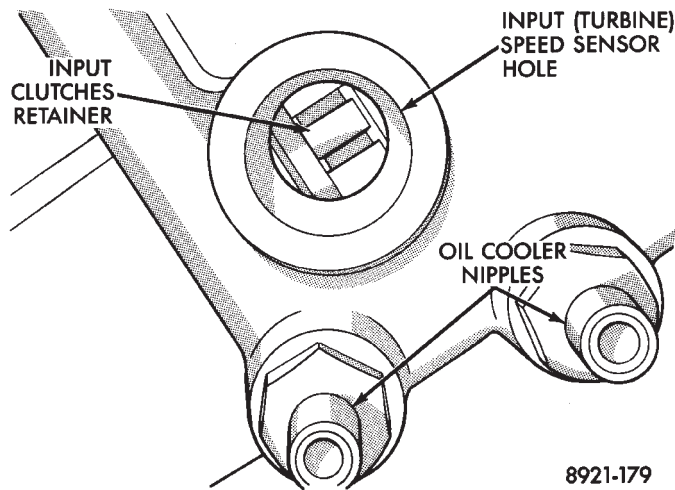

Fig. 89 Select Thinnest No. 4 Thrust Plate



CAUTION: If view through input speed sensor hole is not as shown above, the input clutches assembly is not seated properly.



8921-179

Fig. 90 View Through Input Speed Sensor Hole

CAUTION: Be sure to reinstall O-ring on oil pump after selecting the proper No. 4 thrust plate.

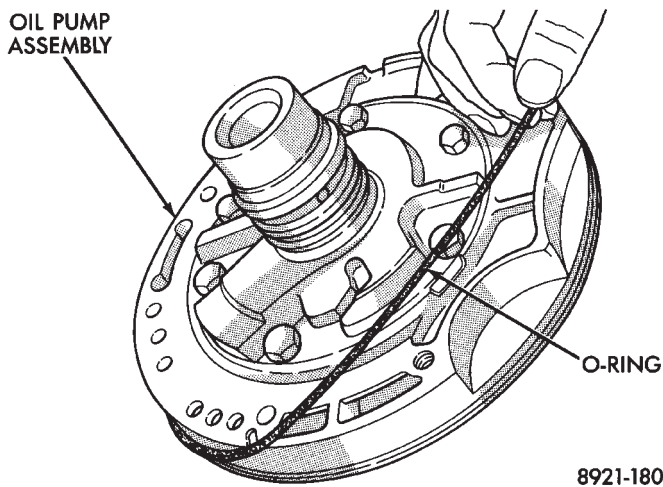

8921-180

Fig. 91 Remove Oil Pump O-Ring

By removing the oil pump O-ring, you will be able to install and remove the oil pump and gasket very easily to select the proper No. 4 thrust plate.

Input shaft end play must be .005 to .025 inch.

For example, if end play reading is .055 inch, select No. 4 Thrust Plate which is .071 to .074 thick. This should provide an input shaft end play reading of .020 inch which is within specifications.

See chart to select the proper No. 4 thrust plate.

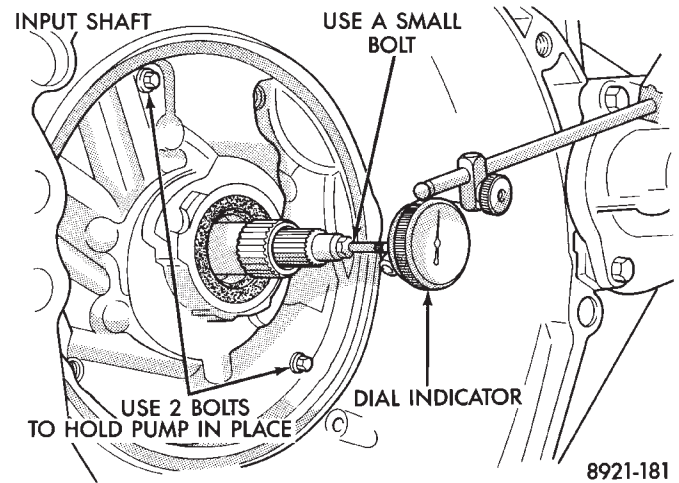

8921-181

Fig. 92 Measure Input Shaft End Play

NO. 4 THRUST PLATE CHART

SHIM THICKNESS	
mm	inch
.81 - 1.03	.032 - .040
1.03 - 1.25	.040 - .049
1.25 - 1.47	.049 - .058
1.47 - 1.69	.058 - .066
1.69 - 1.91	.066 - .075
1.91 - 2.13	.075 - .084
2.13 - 2.35	.084 - .092
2.35 - 2.57	.092 - .101
2.57 - 2.79	.101 - .109
2.79 - 3.01	.109 - .118
3.01 - 3.23	.118 - .131
3.23 - 3.45	.131 - .136

9221-127

INPUT CLUTCHES-RECONDITION

DISASSEMBLY

Tag reverse clutch pack for reassembly identification.

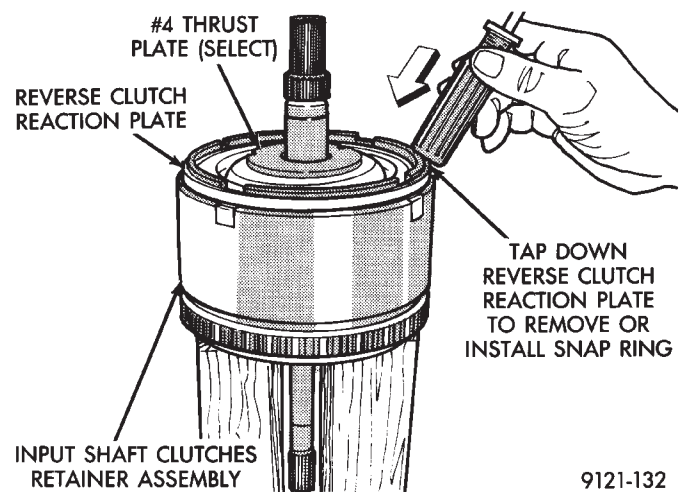

9121-132

Fig. 1 Tapping Reaction Plate

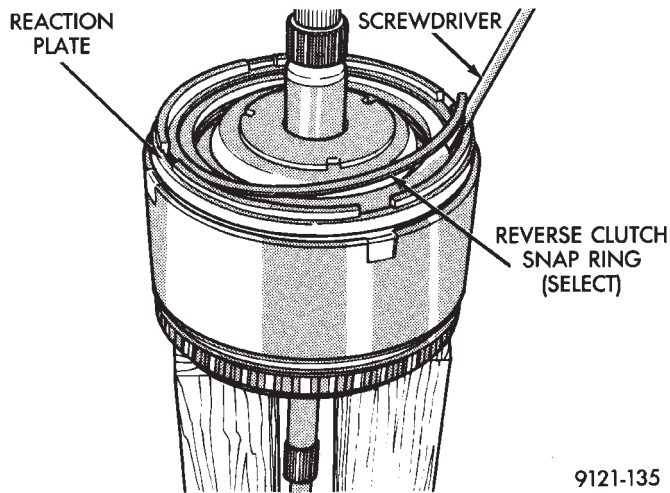

9121-135

Fig. 2 Reverse Clutch Snap Ring

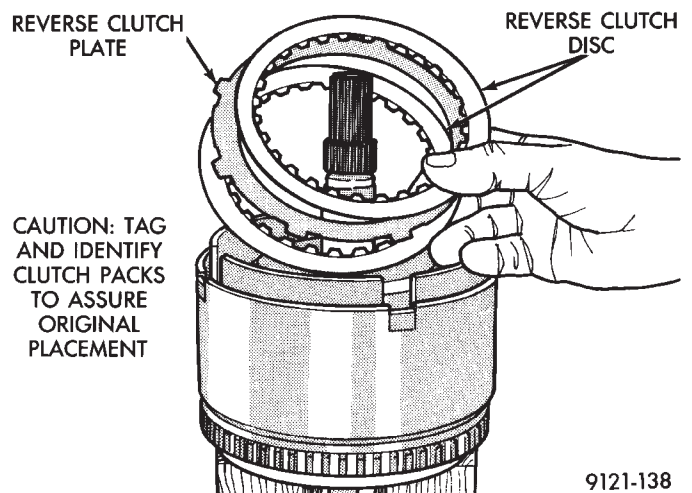

9121-138

Fig. 5 Reverse Clutch Pack

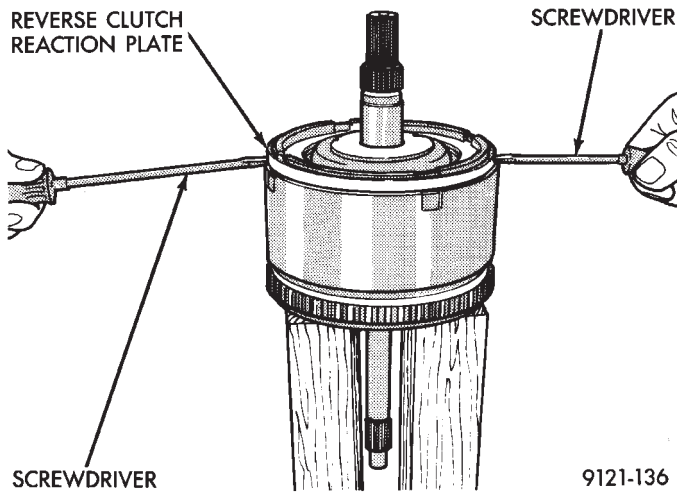

9121-136

Fig. 3 Pry Reverse Clutch Reaction Plate

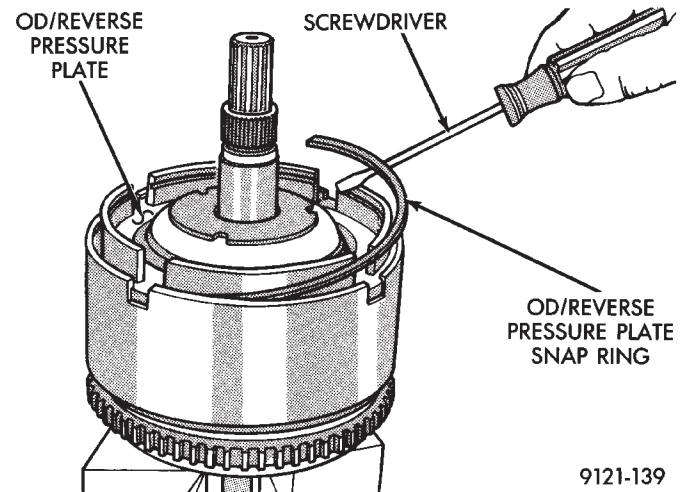

9121-139

Fig. 6 OD/Reverse Pressure Plate Snap Ring 192195

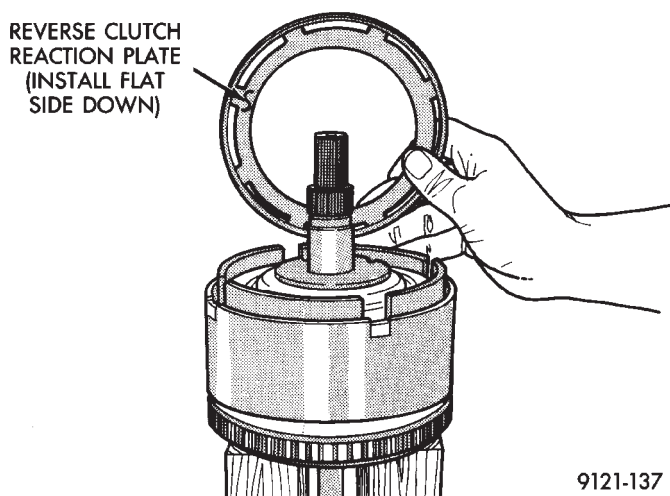

9121-137

Fig. 4 Reverse Clutch Reaction Plate

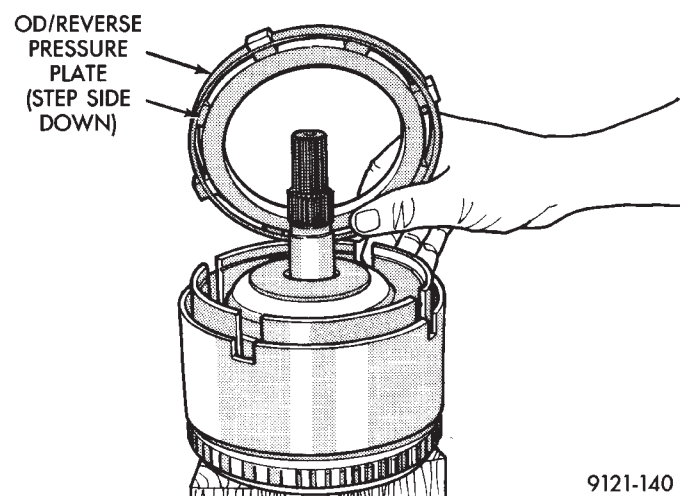

9121-140

Fig. 7 OD/Reverse Pressure Plate

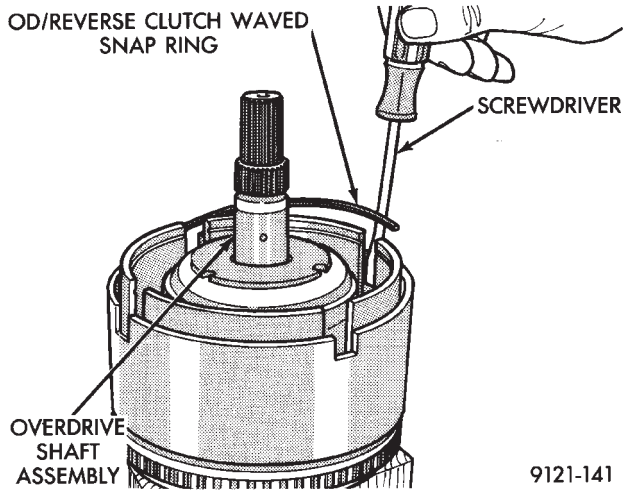

9121-141

Fig. 8 Waved Snap Ring

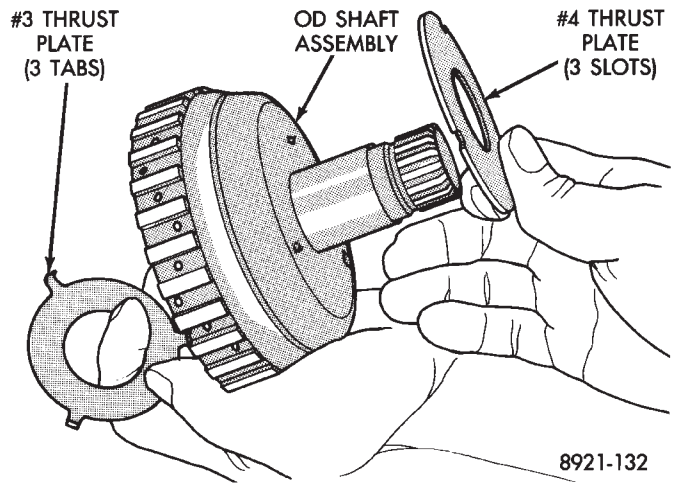

8921-132

Fig. 11 Overdrive Shaft Assembly

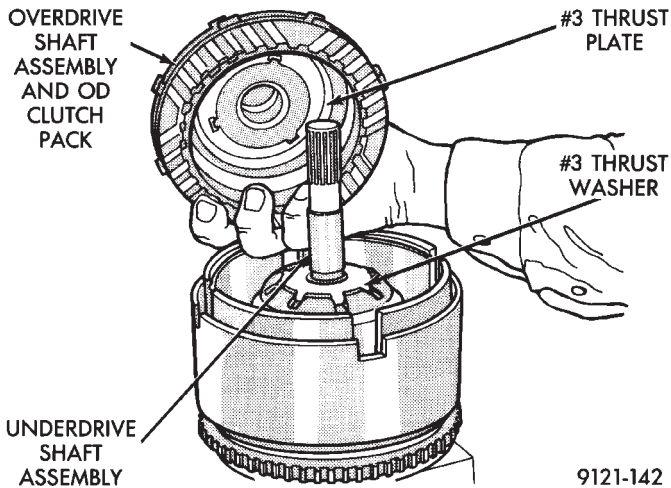

9121-142

Fig. 9 Remove OD Clutch Pack

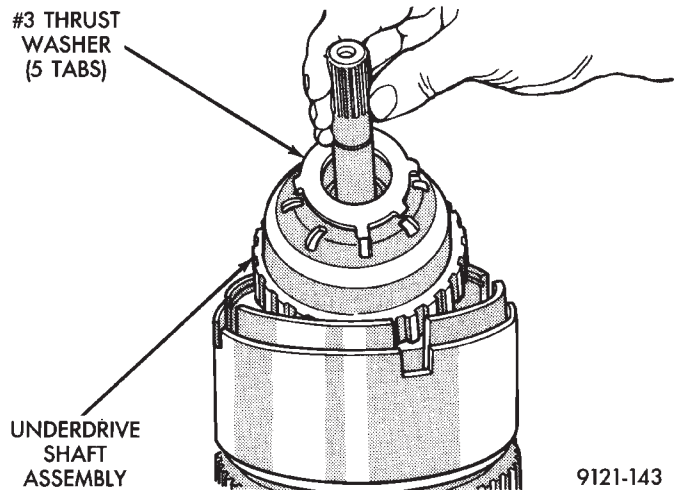

9121-143

Fig. 12 Underdrive Shaft Assembly

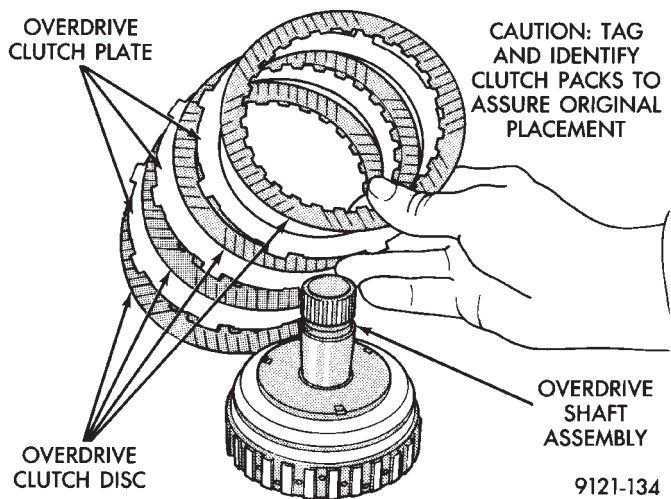

9121-134

Fig. 10 Overdrive Clutch Pack

Tag overdrive clutch pack for reassembly identification.

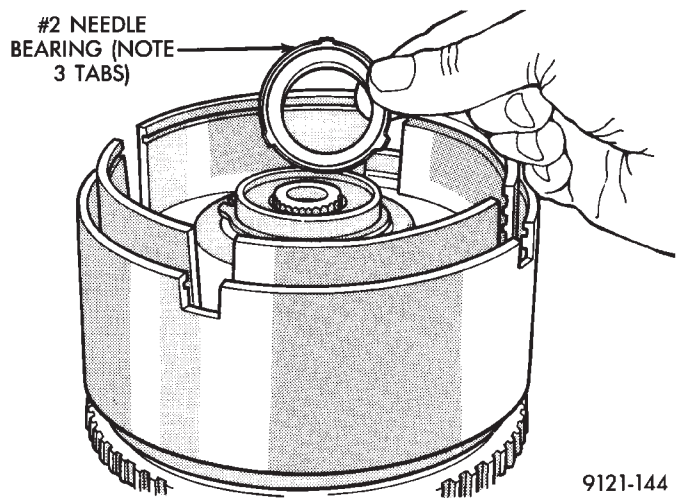

9121-144

Fig. 13 No. 2 Needle Bearing

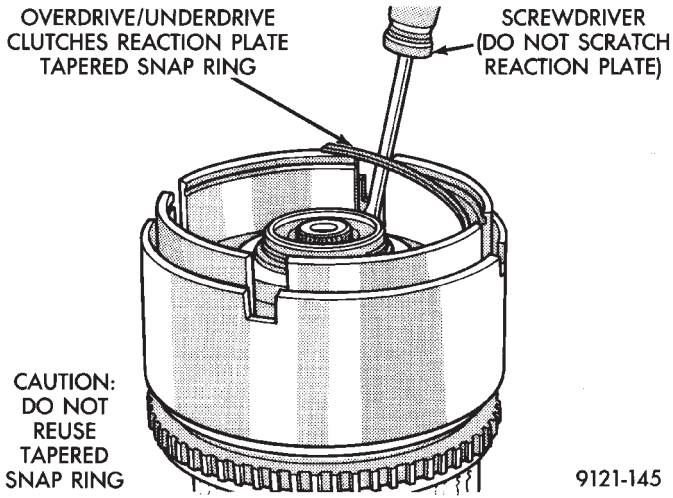

9121-145

Fig. 14 OD/UD Reaction Plate Tapered Snap Ring

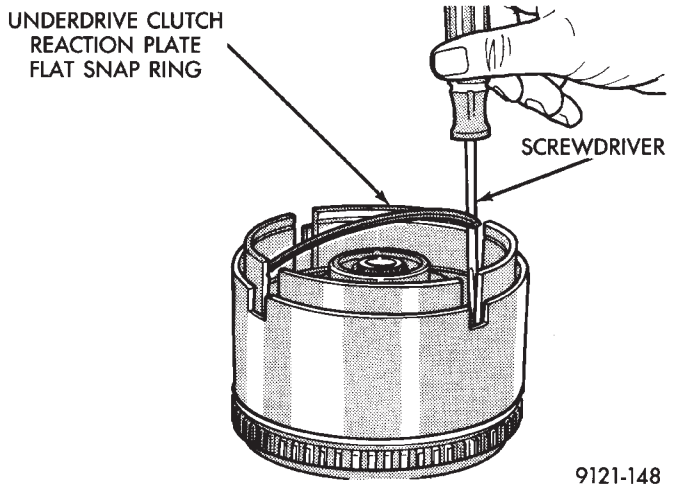

9121-148

Fig. 17 UD Clutch Flat Snap Ring

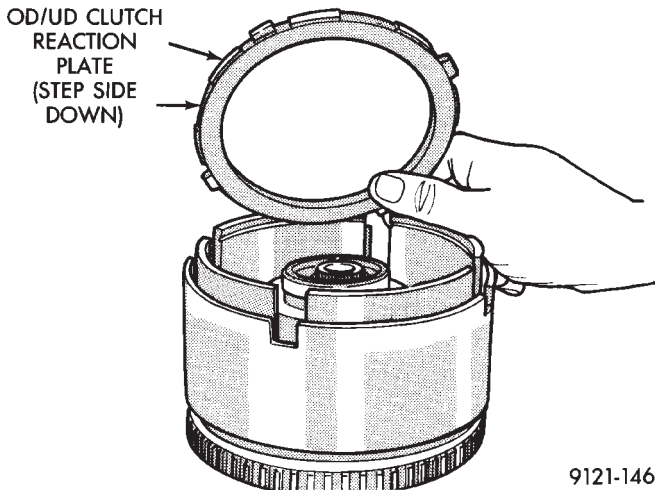

9121-146

Fig. 15 OD/UD Reaction Plate

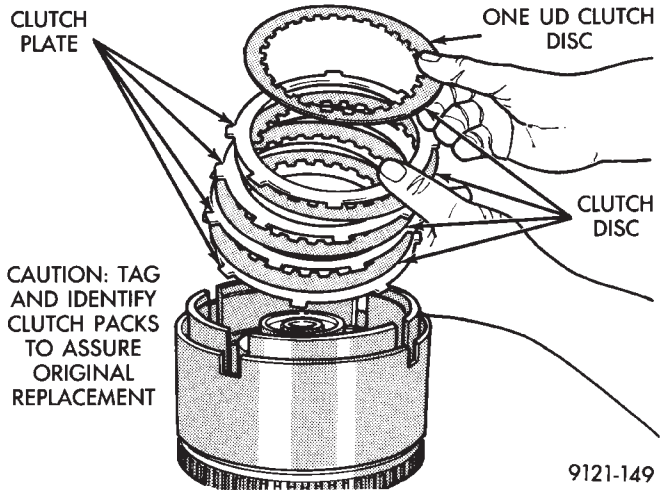

9121-149

Fig. 18 Underdrive Clutch Pack

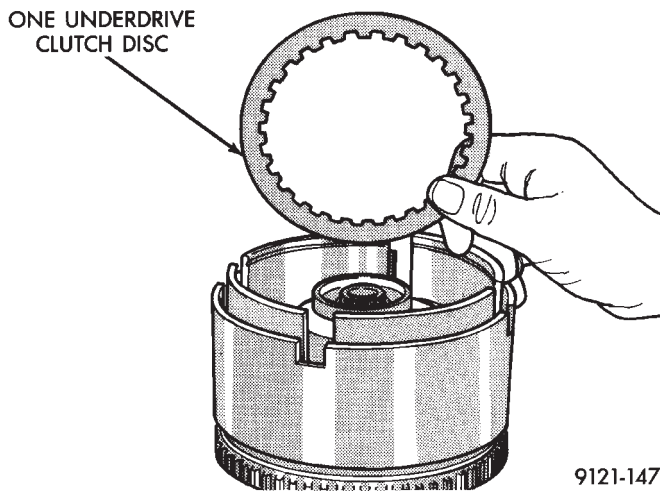

9121-147

Fig. 16 Remove One UD Clutch Disc

Tag underdrive clutch pack for reassembly identification.

CAUTION: Compress return spring just enough to remove or install snap ring.

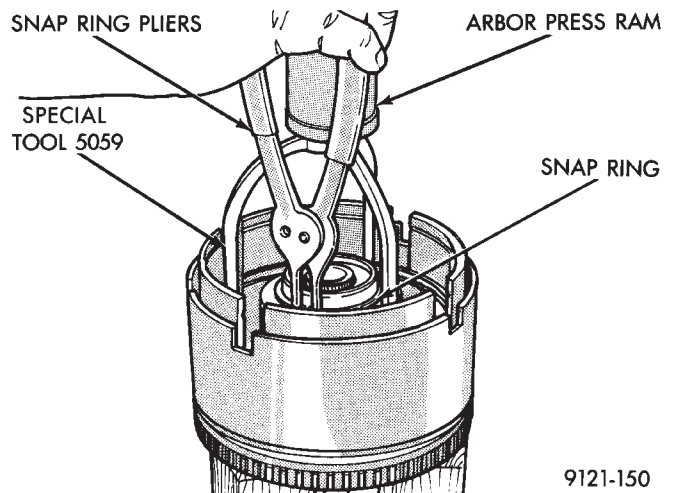

9121-150

Fig. 19 UD Spring Retainer Snap Ring

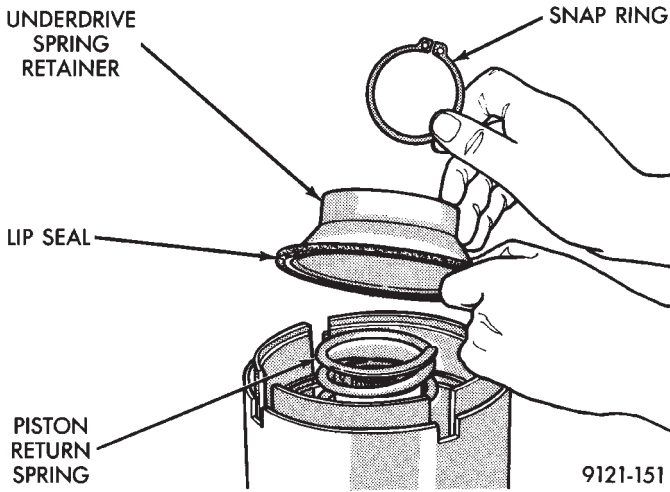

Fig. 20 UD Return Spring and Retainer

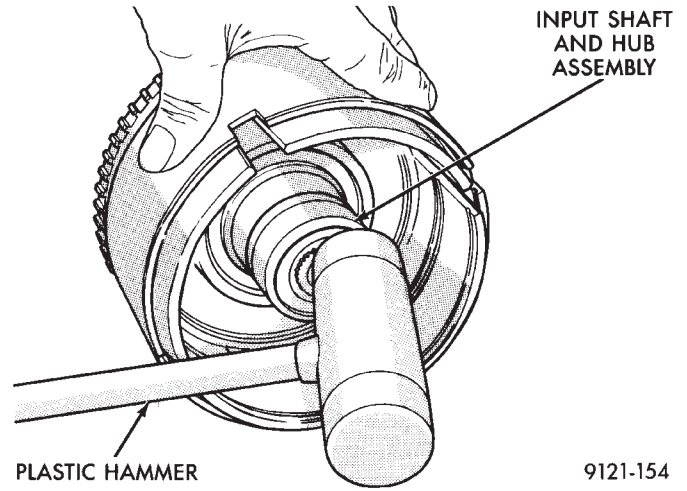

Fig. 23 Tap on Input Hub

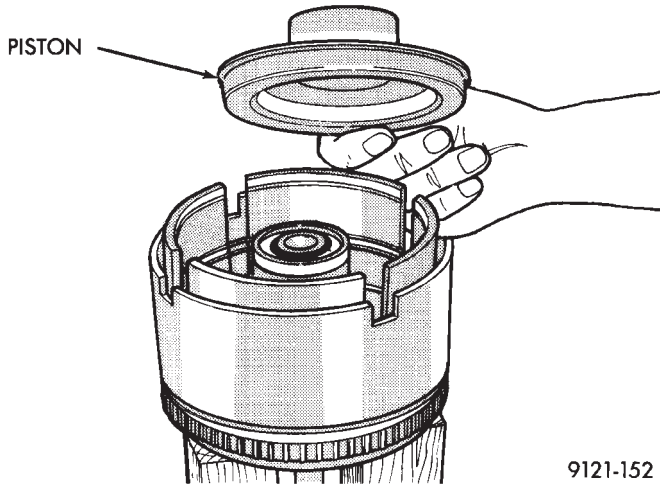

Fig. 21 Underdrive Clutch Piston

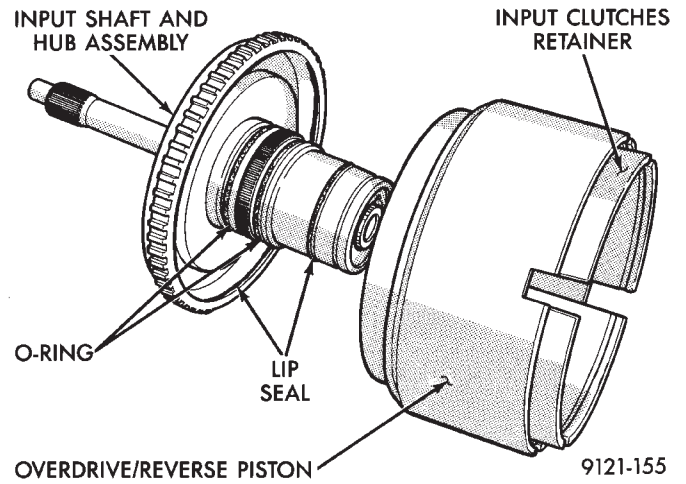

Fig. 24 Input Hub Removed

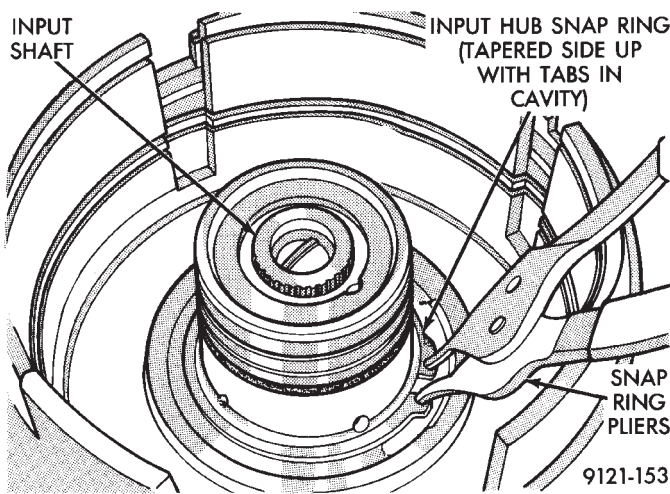

Fig. 22 Input Hub Tapered Snap Ring

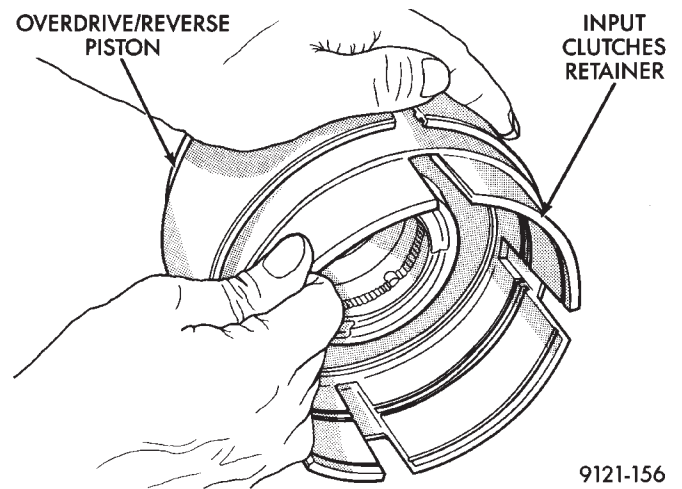

Fig. 25 Pull Retainer from Piston

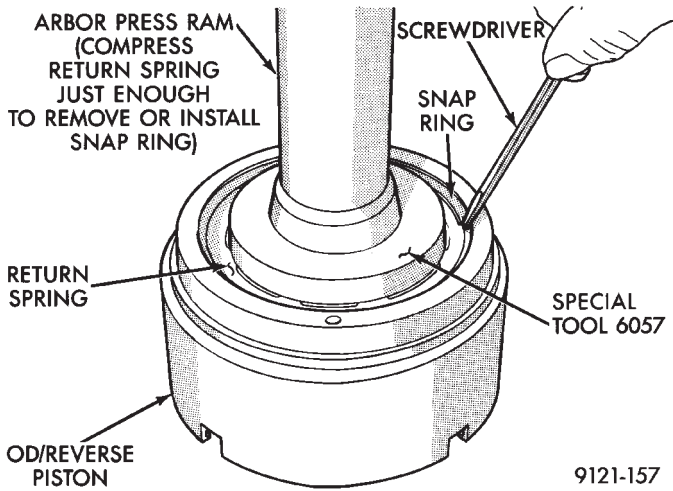

Fig. 26 Install Snap Ring

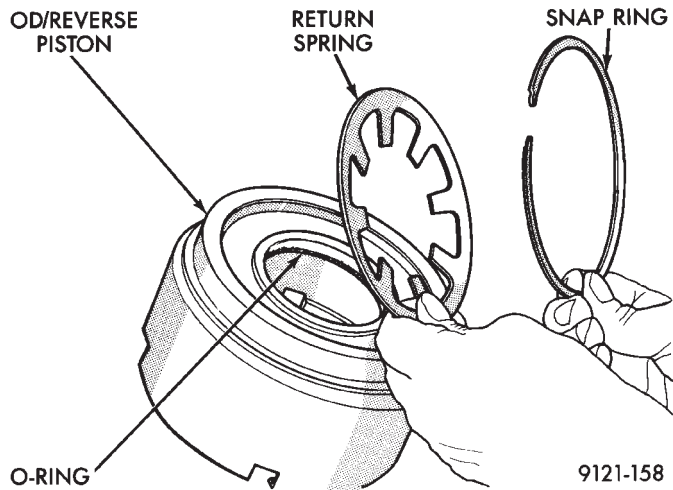

Fig. 27 Snap Ring and Return Spring

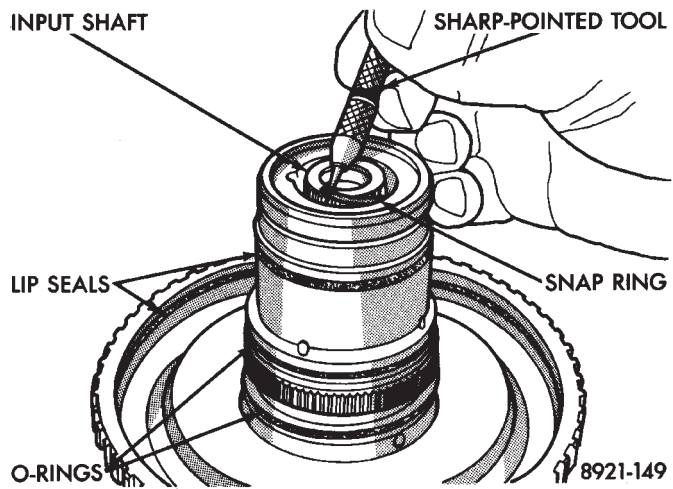

Fig. 28 Remove Input Shaft Snap Ring

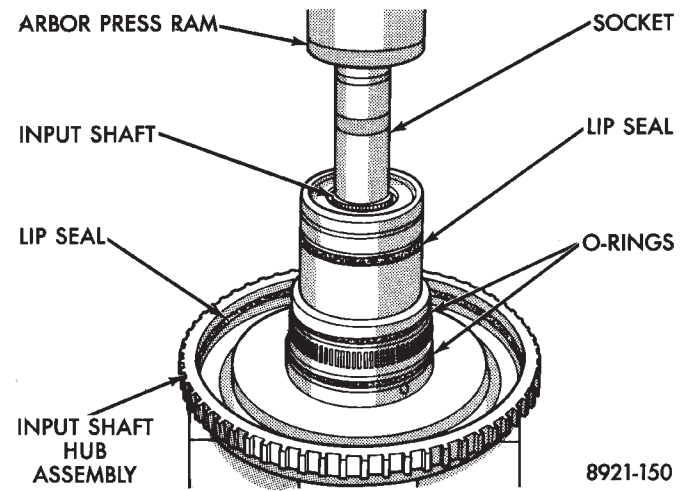

Fig. 29 Remove Input Shaft

ASSEMBLY
Use petrolatum on all seals to ease assembly of components.

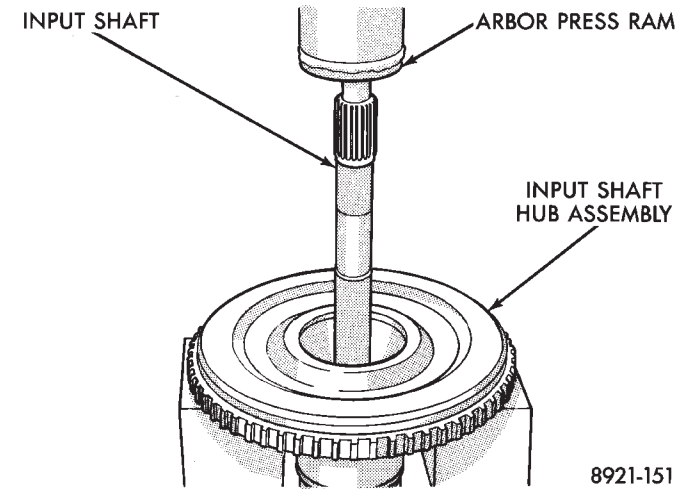

Fig. 1 Install Input Shaft

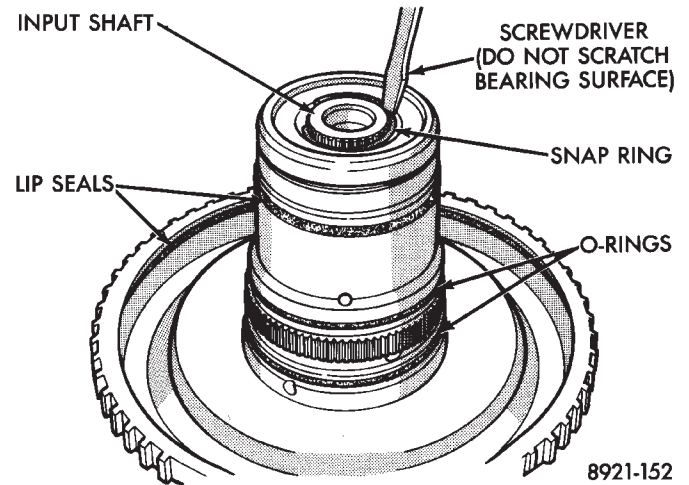
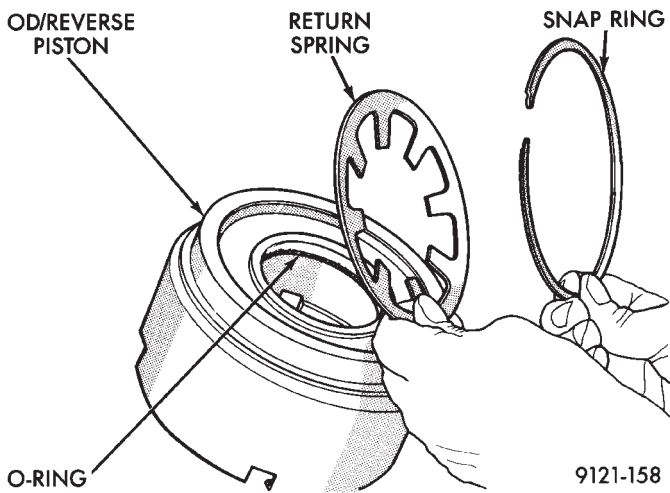
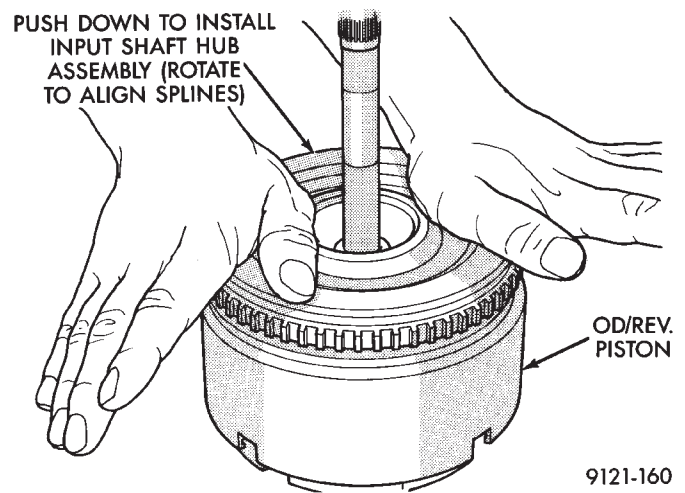

Fig. 2 Install Input Shaft Snap Ring



9121-158

Fig. 3 Return Spring and Snap Ring



9121-160

Fig. 6 Install Input Shaft Hub Assembly

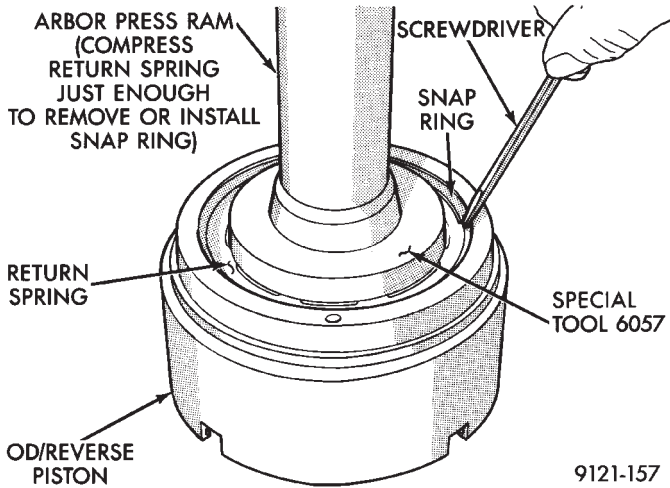

9121-157

Fig. 4 Install Snap Ring

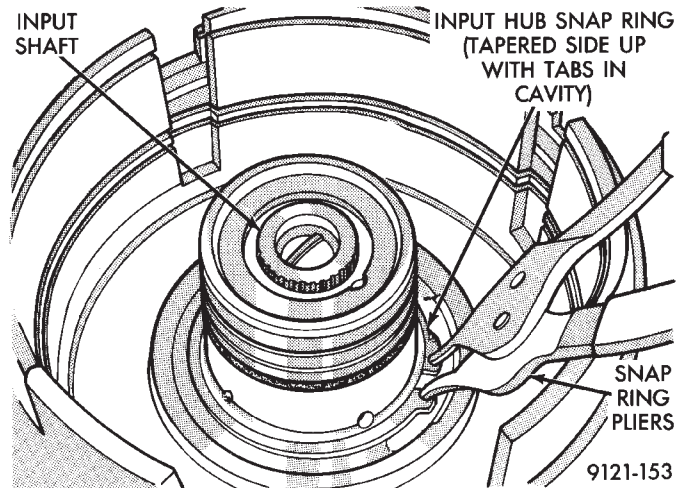

9121-153

Fig. 7 Input Hub Tapered Snap Ring

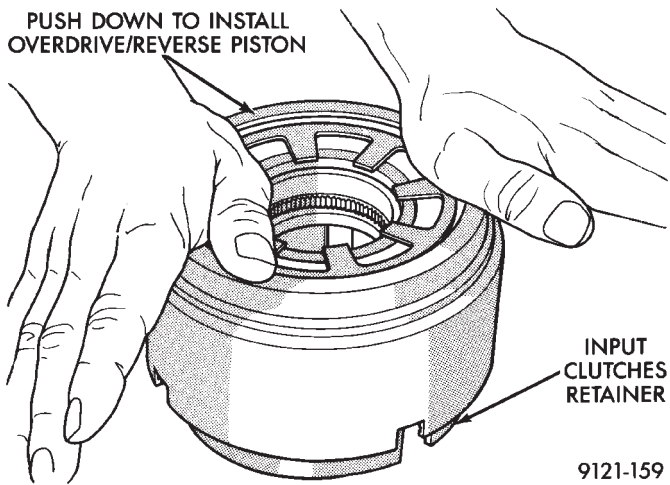

9121-159

Fig. 5 Install OD/Reverse Piston

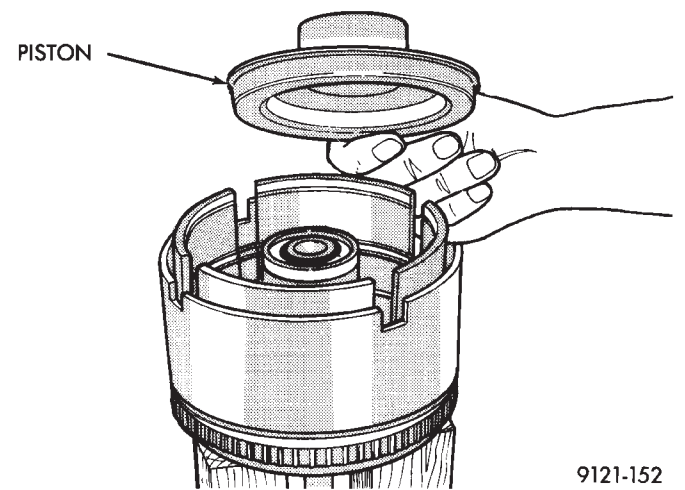

9121-152

Fig. 8 Underdrive Clutch Piston

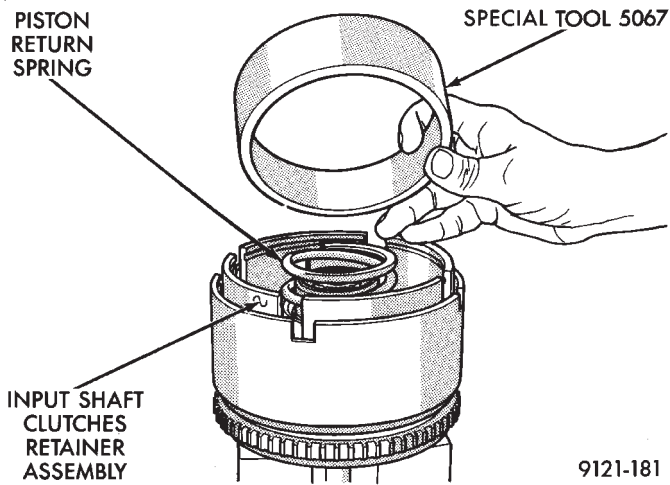

Fig. 9 Seal Compressor Tool 5067

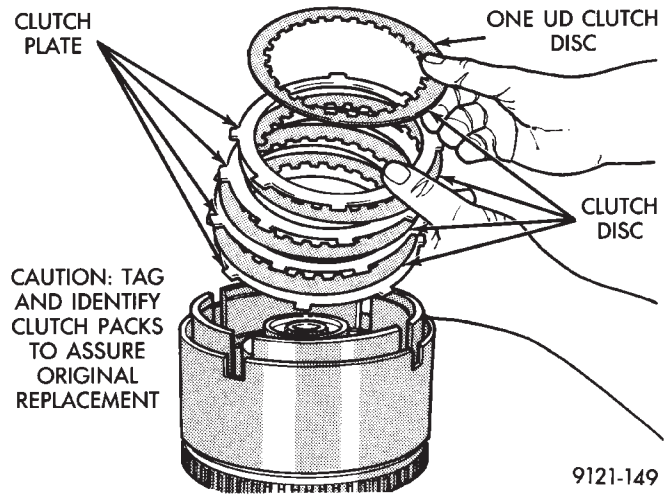

Fig. 12 Underdrive Clutch Pack

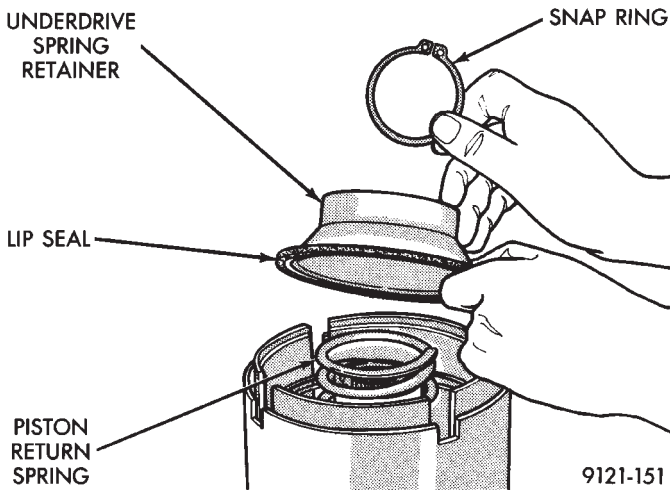

Fig. 10 UD Return Spring and Retainer

CAUTION: Compress return spring just enough to remove or install snap ring.

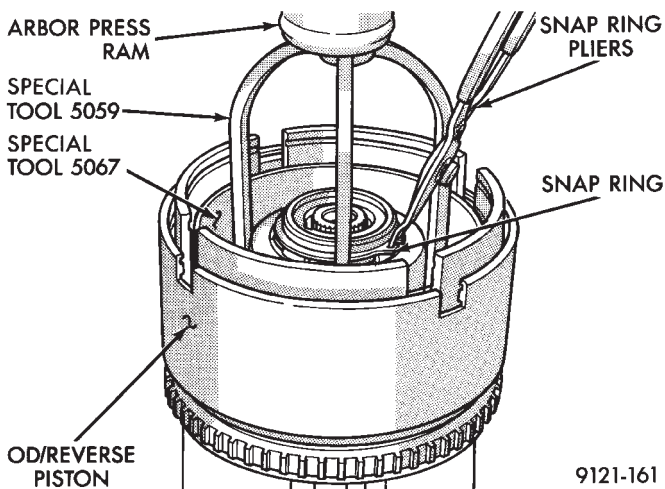

Fig. 11 Install UD Spring Retainer and Snap Ring

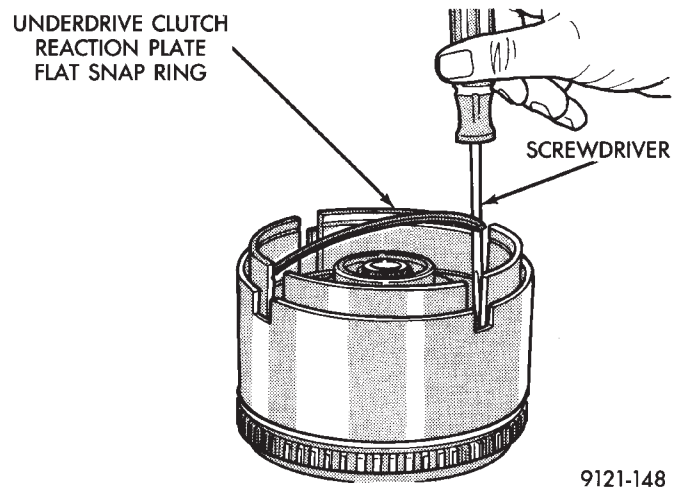

Fig. 13 UD Clutch Flat Snap Ring

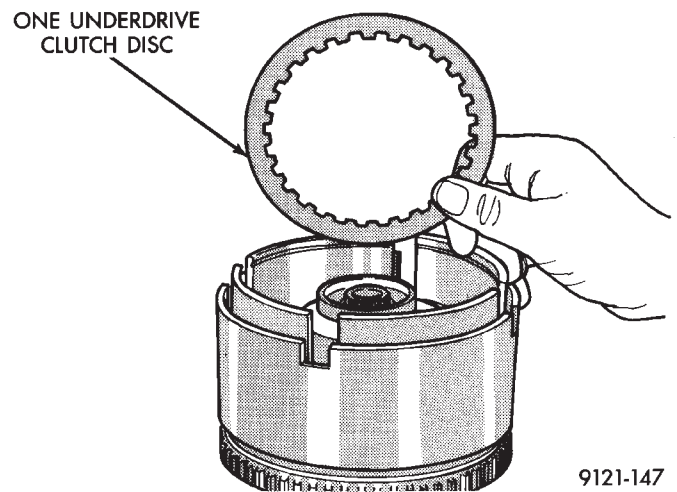
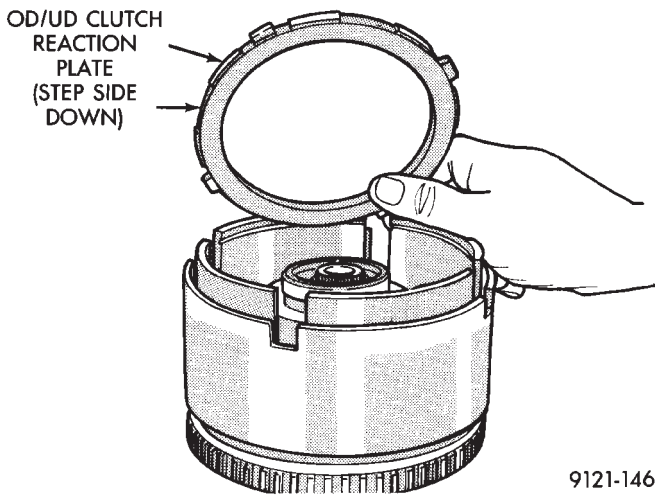
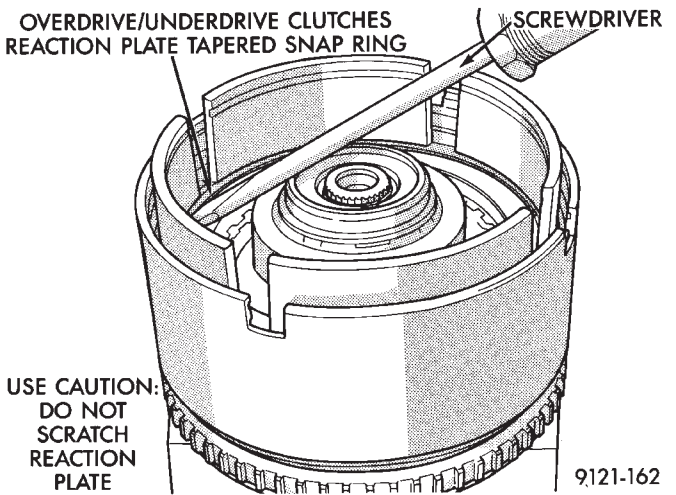

Fig. 14 Install Last UD Clutch Disc



9121-146

Fig. 15 OD/UD Reaction Plate



9121-162

Fig. 17 Seating Tapered Snap Ring

USE CAUTION:
DO NOT
SCRATCH
REACTION
PLATE

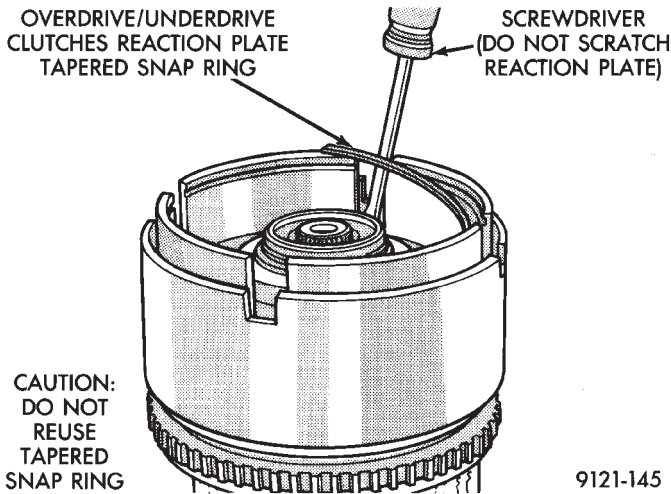

9121-145

Fig. 16 Tapered Snap Ring

CAUTION:
DO NOT
REUSE
TAPERED
SNAP RING

SCREWDRIVER
(DO NOT SCRATCH
REACTION PLATE)

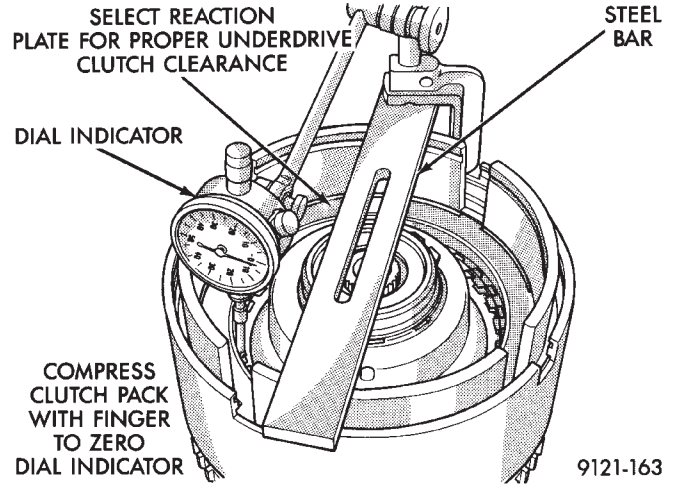

9121-163

Fig. 18 Set Up Dial Indicator for Clutch Clearance

Snap ring ends must be located within one finger of the input clutch hub. Be sure that snap ring is fully seated, by pushing with screwdriver, into snap ring groove all the way around.

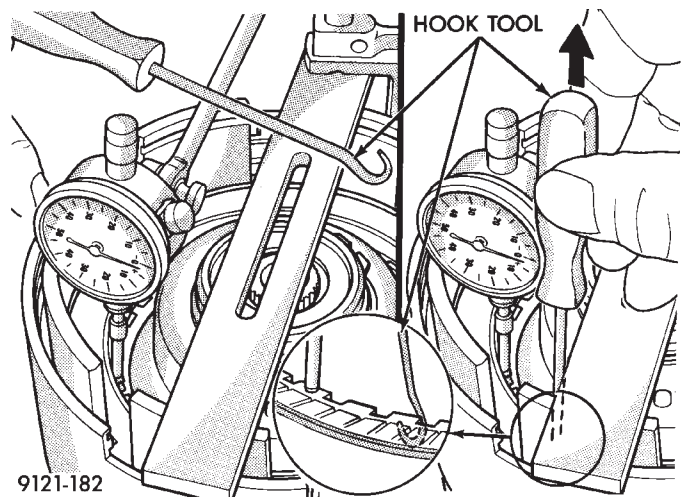

9121-182

Fig. 19 Use Hook Tool to Raise One Clutch Disc



Underdrive clutch pack clearance must be 0.91 to 1.47mm (.036 to .058 inch). Select the proper reaction plate to achieve specifications:

UNDERDRIVE REACTION PLATE CHART

THICKNESS
6.99 mm (.275 in.)
6.50 mm (.256 in.)
6.01 mm (.237 in.)
5.52 mm (.217 in.)

9121-5

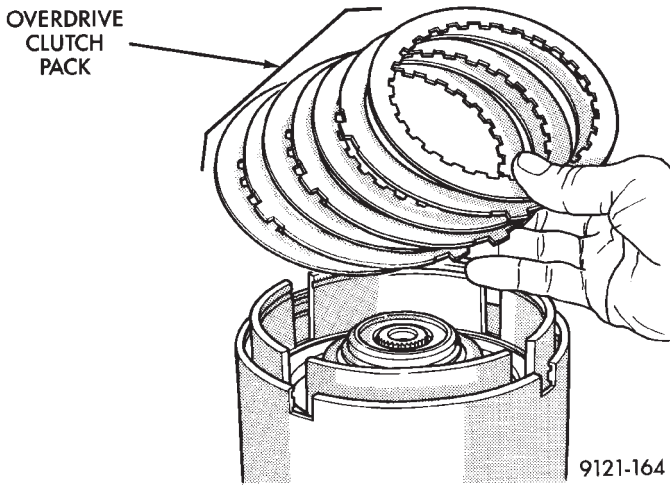

Fig. 20 Install OD Clutch Pack

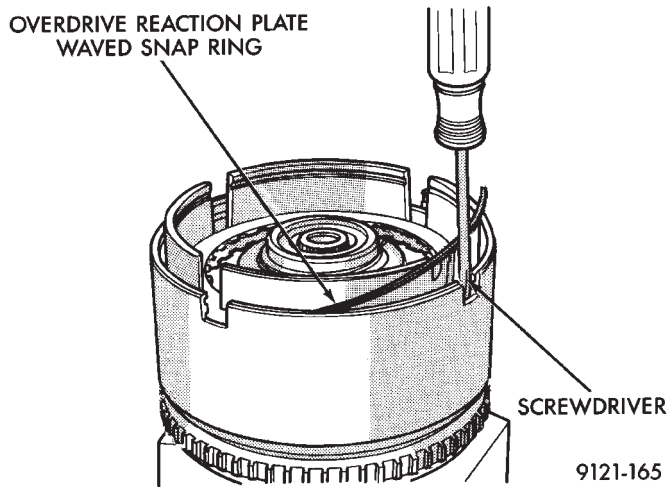

Fig. 21 Install Waved Snap Ring

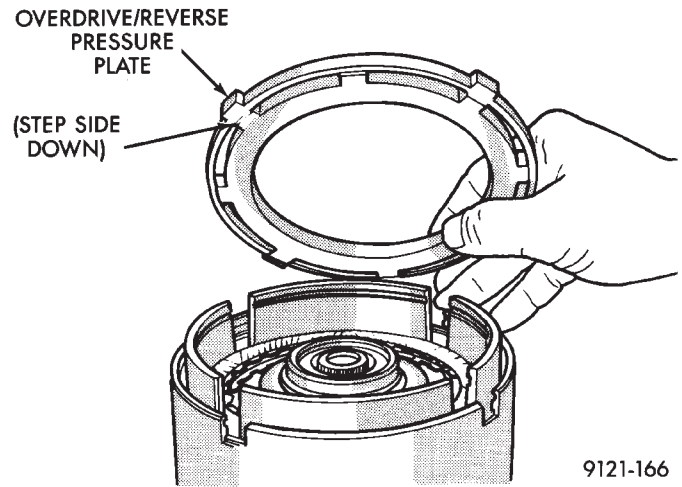

Fig. 22 OD/Reverse Pressure Plate

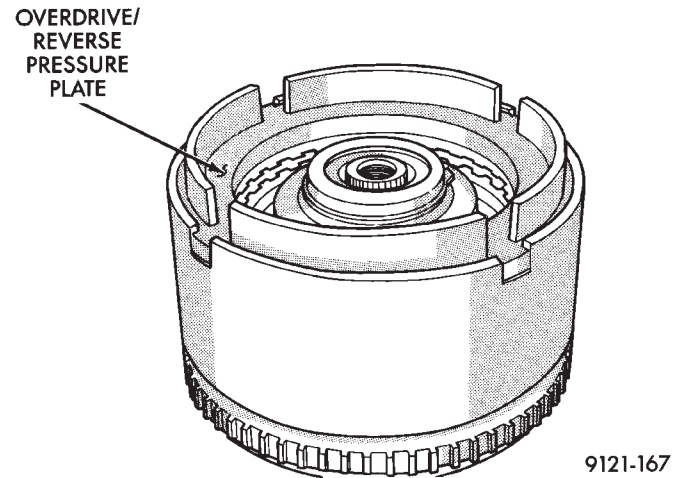

Fig. 23 Pressure Plate Installed

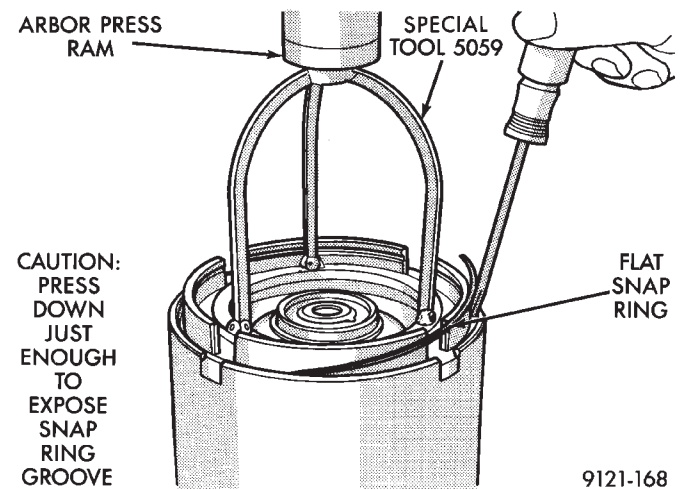

Fig. 24 Install Flat Snap Ring

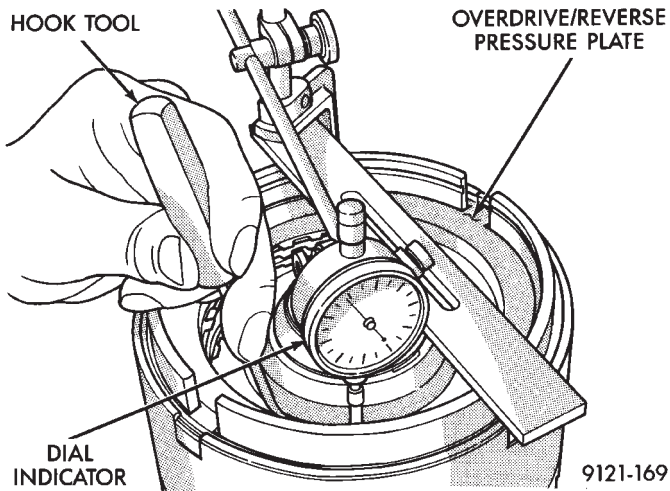

Fig. 25 Check OD Clutch Pack Clearance

The overdrive (OD) clutch pack clearance is .965 to 2.26 mm (.038 to .089 inch). If not within specifications, the clutch is not assembled properly. There is no adjustment for the OD clutch clearance.

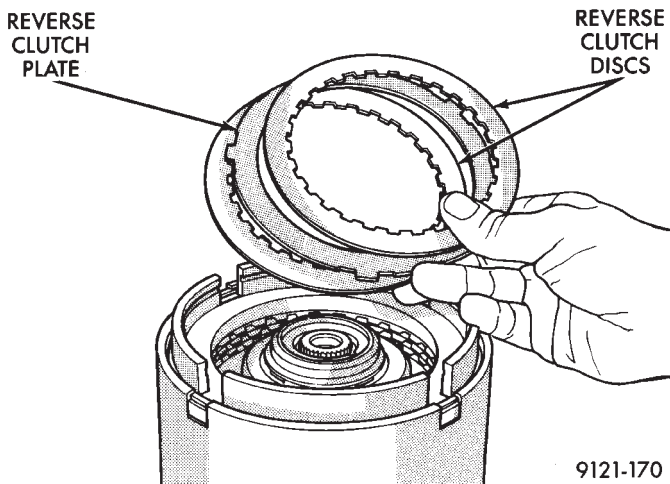

Fig. 26 Install Reverse Clutch Pack

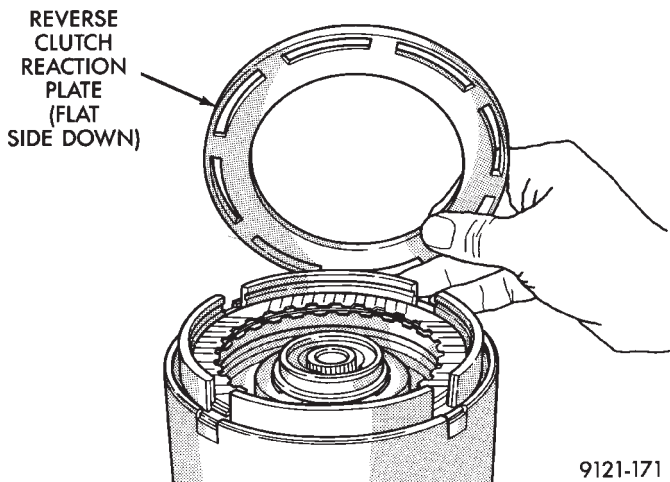

Fig. 27 Install Reaction Plate

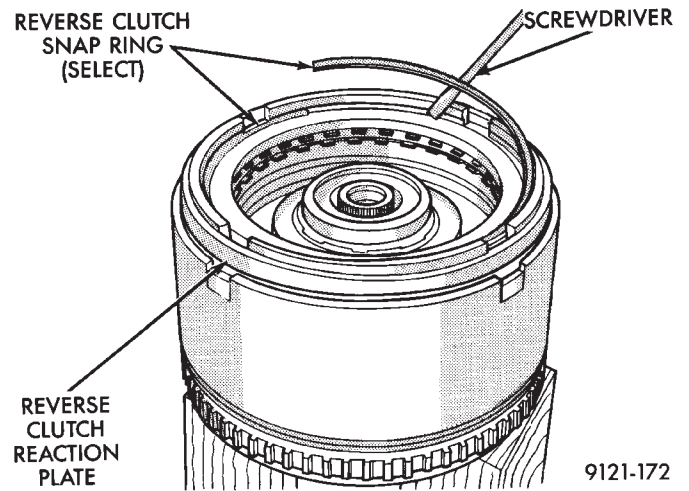

Fig. 28 Install Reverse Clutch Snap Ring

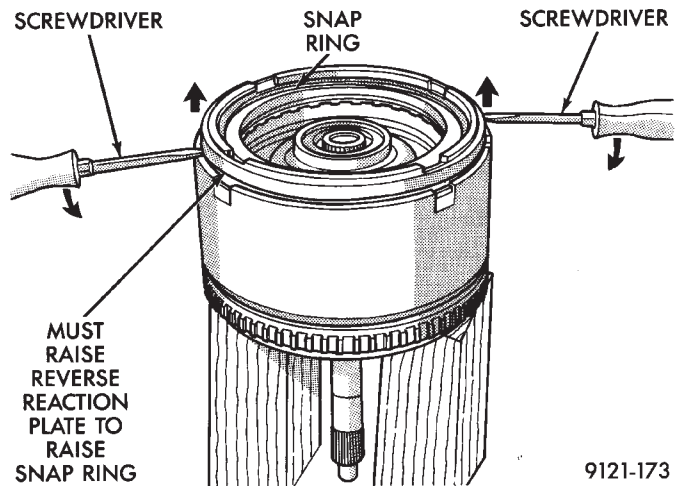

Fig. 29 Seating Snap Ring to Determine Reverse Clutch Clearance

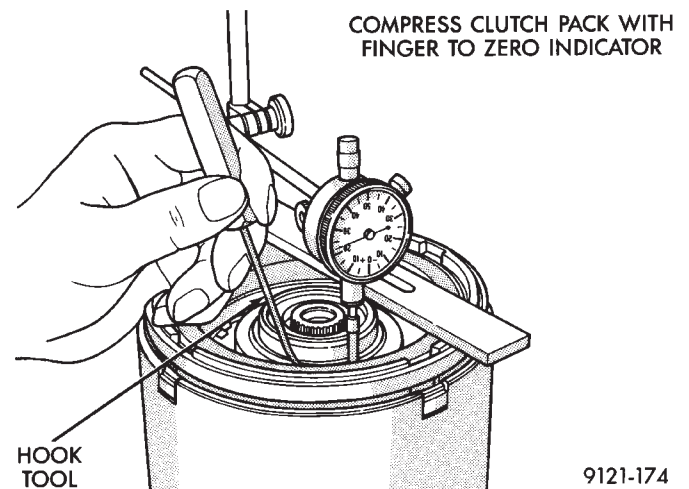

Fig. 30 Check Reverse Clutch Pack Clearance



The reverse clutch pack clearance is 0.76 to 1.24mm (.030 to .049 inch). Select the proper reverse clutch snap ring to achieve specifications:

REVERSE CLUTCH SNAP RING CHART

THICKNESS
1.56 mm (.061 in.)
1.80 mm (.071 in.)
2.05 mm (.081 in.)
2.30 mm (.090 in.)

9121-6

All clutch clearances in the input clutches retainer have now been checked and approved.

To complete the assembly of the input clutches retainer, the reverse clutch and the overdrive clutch must be removed from the retainer.

CAUTION: Do not intermix clutch parts. Keep in exact same order.

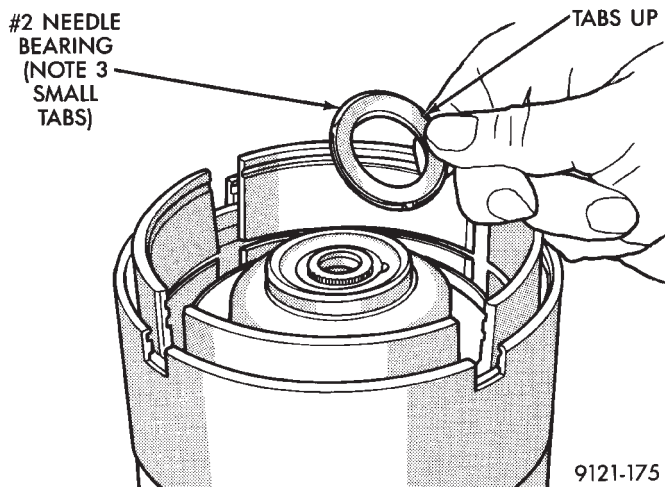

9121-175

Fig. 31 Install No. 2 Needle Bearing

Now proceed with the next phase of the assembly:

Now that both shaft assemblies and thrust washers are properly installed, reinstall overdrive clutch and reverse clutch as shown in Figures 20 through 28. **Rechecking these clutch clearances is not necessary, as they were set and approved previously.**

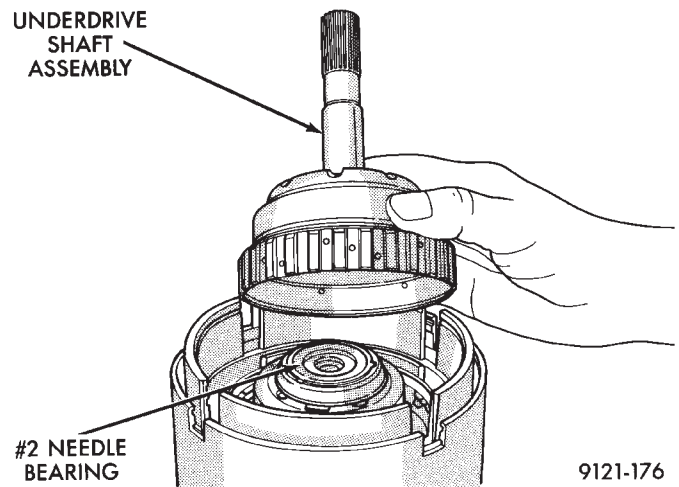

9121-176

Fig. 32 Install Underdrive Shaft Assembly

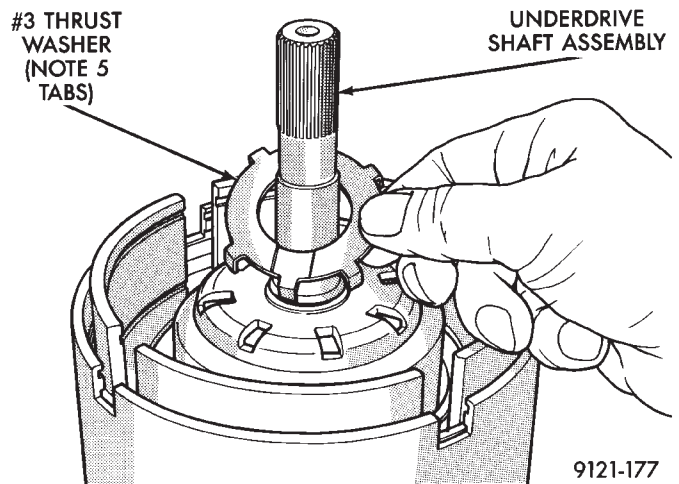

9121-177

Fig. 33 Install No. 3 Thrust Washer

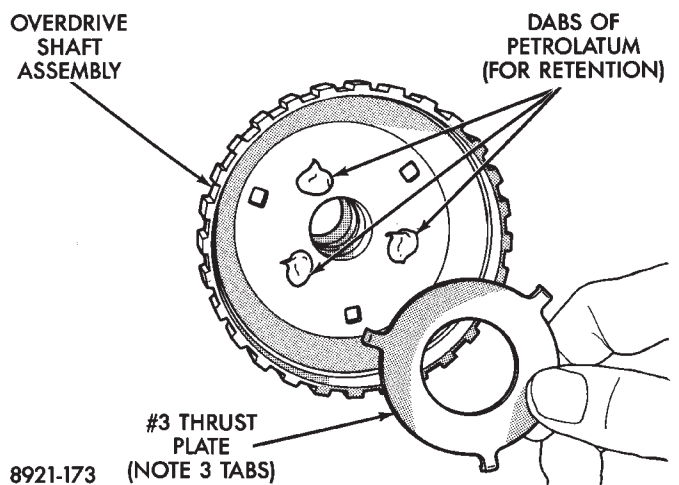

8921-173

Fig. 34 Install No. 3 Thrust Plate

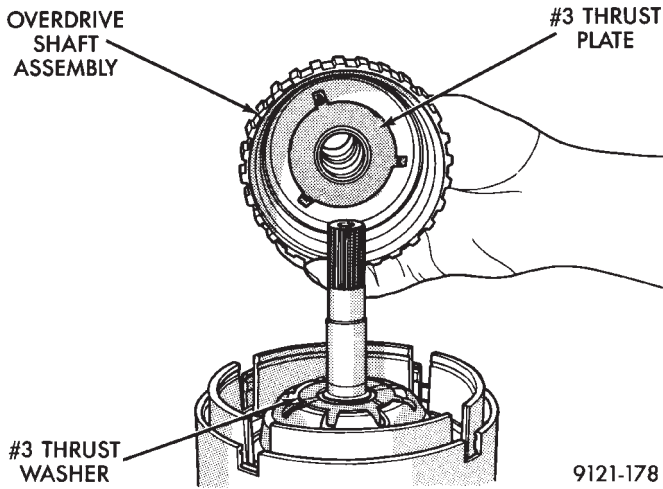

Fig. 35 Install Overdrive Shaft Assembly

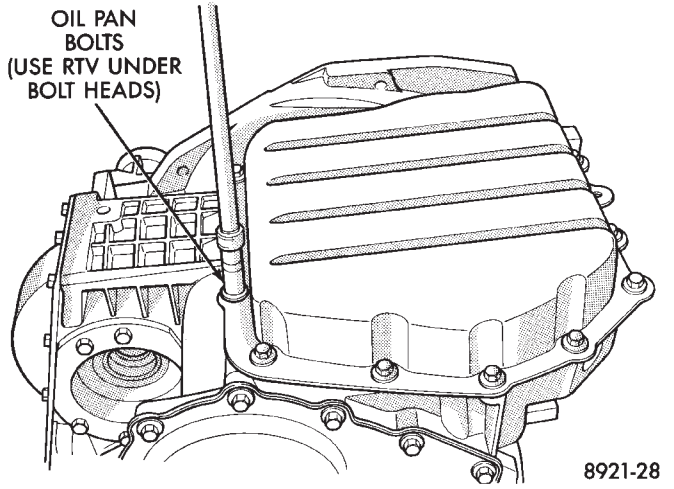

Fig. 1 Oil Pan Bolts

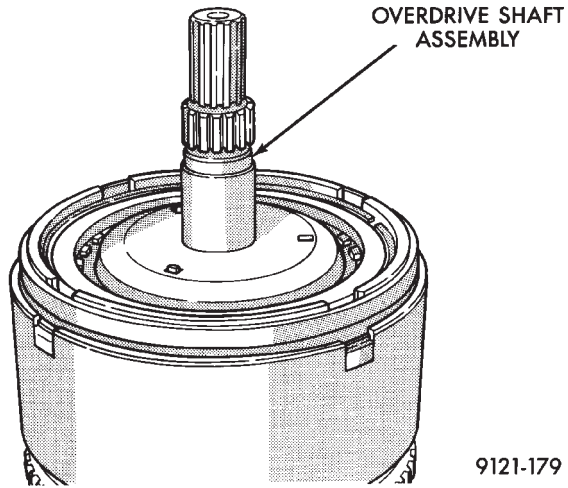

Fig. 36 Input Clutches Assembly

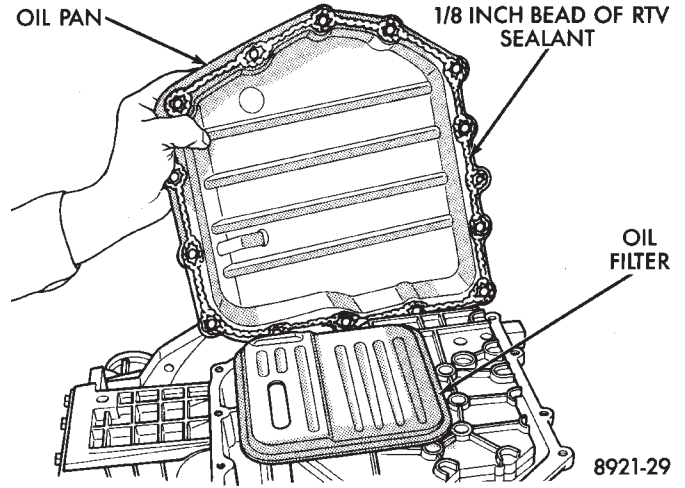

Fig. 2 Oil Pan

VALVE BODY-RECONDITION

Prior to removing any transaxle subassemblies, plug all openings and thoroughly clean exterior of the unit, preferably by steam. Cleanliness through entire disassembly and assembly cannot be overemphasized. When disassembling, each part should be washed in a suitable solvent, then dried by compressed air. **Do not wipe parts with shop towels.** All mating surfaces in the transaxles are accurately machined; therefore, careful handling of all parts must be exercised to avoid nicks or burrs.

Tag all springs, as they are removed, for reassembly identification.

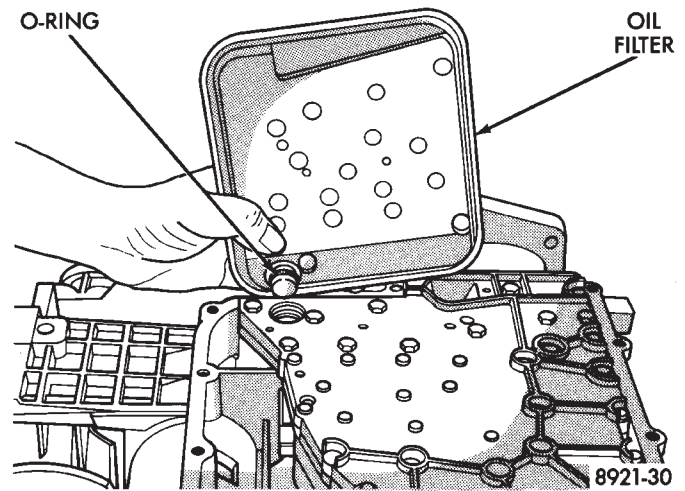

Fig. 3 Oil Filter

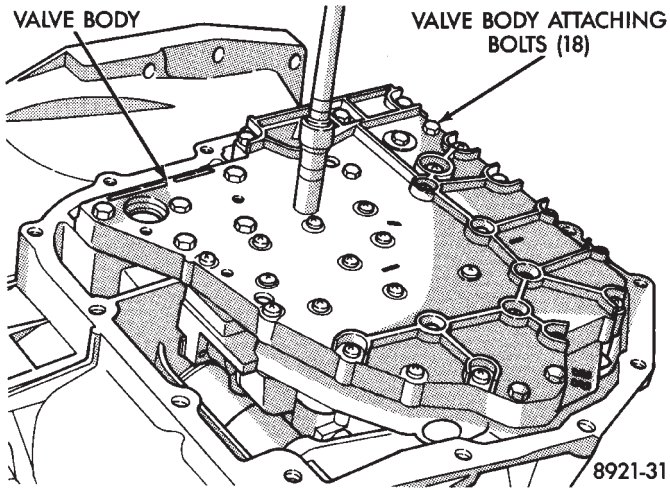

Fig. 4 Valve Body Attaching Bolts

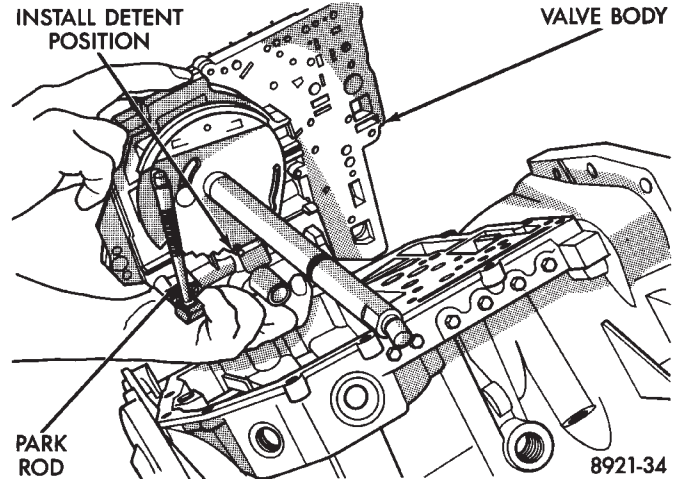

Fig. 7 Valve Body Removed

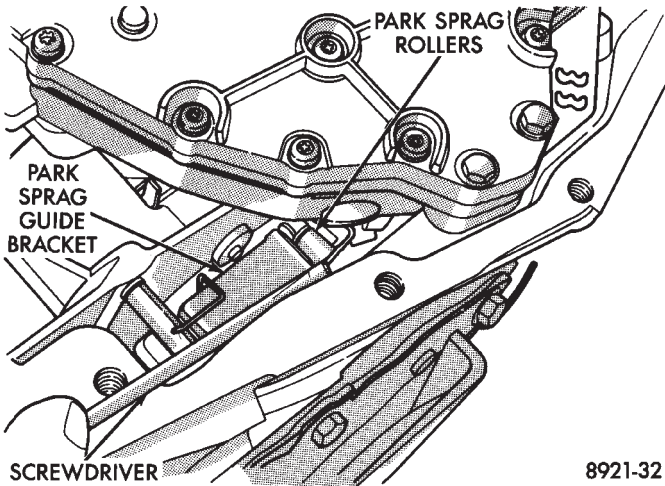

Fig. 5 Push Park Rod Rollers from Guide Bracket

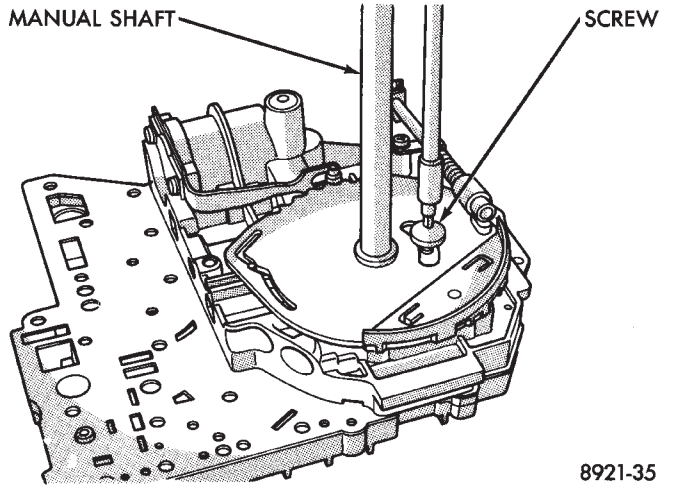

Fig. 8 Manual Shaft Screw

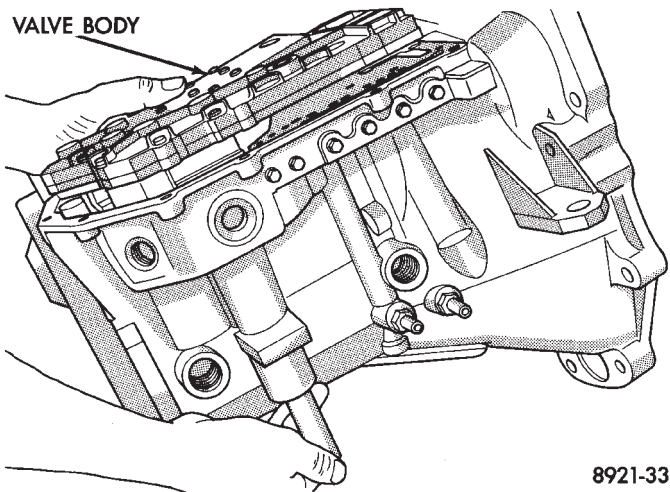

Fig. 6 Remove or Install Valve Body

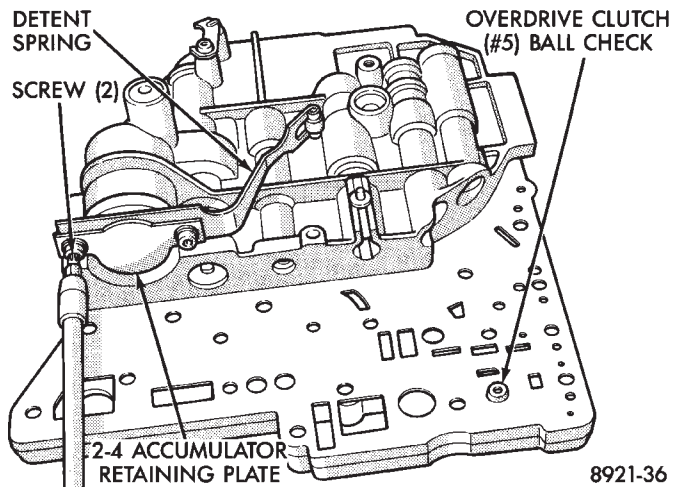

Fig. 9 Retaining Plate Screw

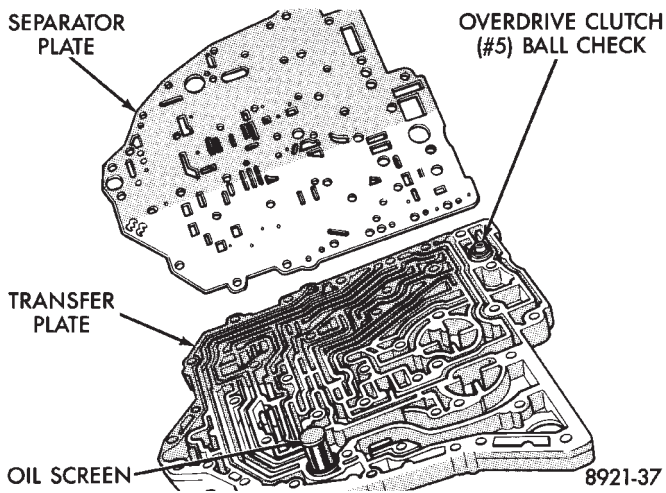

Fig. 10 Transfer Plate and Separator Plate

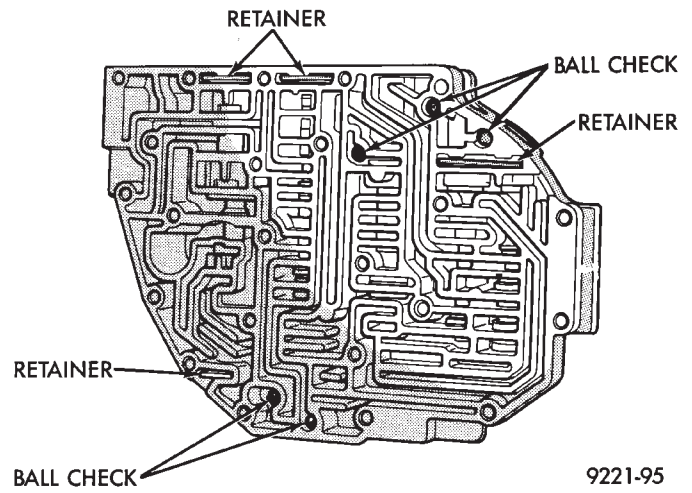

Fig. 12 Ball Check and Retainer Locations

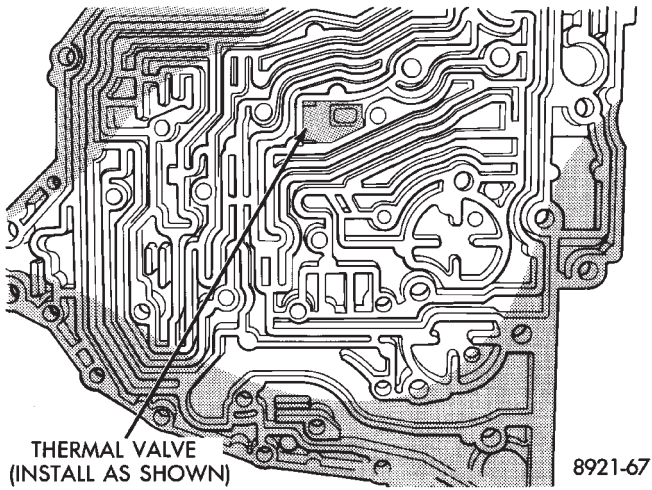
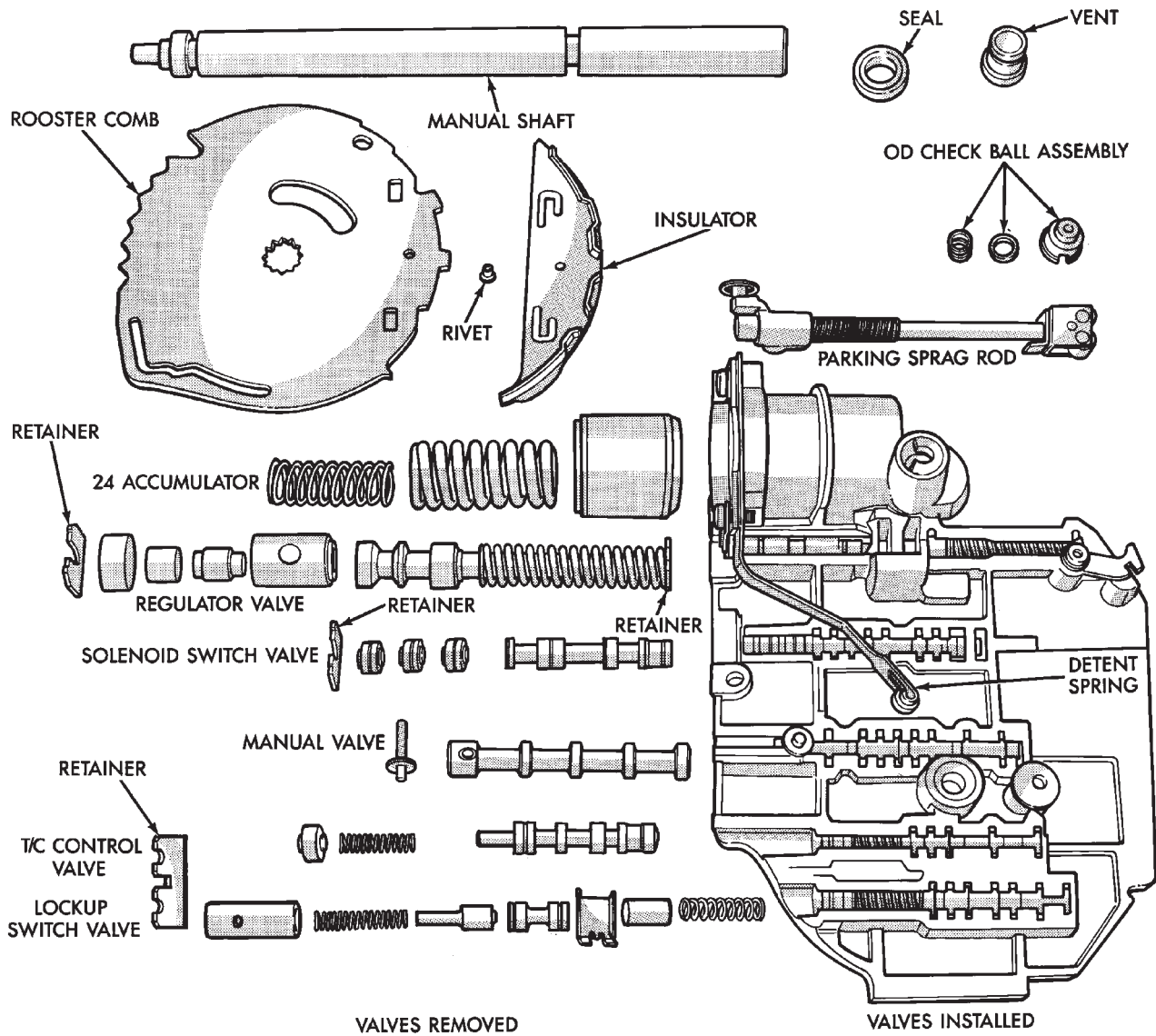

Fig. 11 Transfer Plate



9221-96

Fig. 13 Springs and Valves Identification

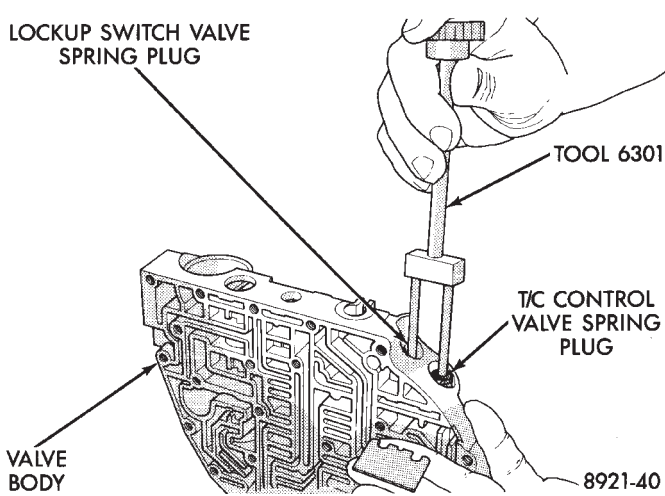

Fig. 14 Remove or Install Dual Retainer Plate

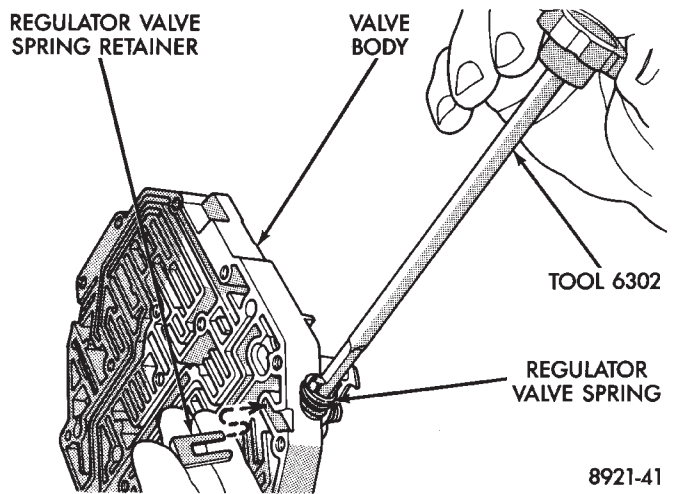

Fig. 15 Remove or Install Retainer Plate



When installing valve body assembly onto transaxle, observe Figure 5. Guide park rod rollers into guide bracket, while shifting manual lever assembly out of the installation position.

OIL PUMP SEAL-REPLACE

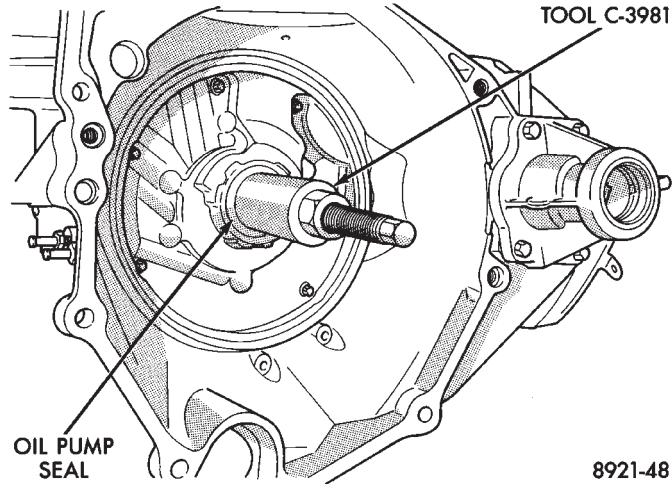

Fig. 16 Remove Oil Pump Seal

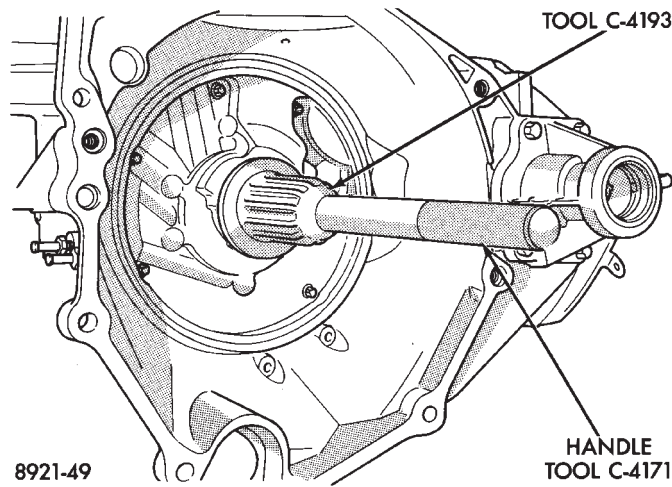

Fig. 17 Install Oil Pump Seal

DIFFERENTIAL REPAIR

The transfer shaft should be removed for differential repair and bearing turning torque checking.

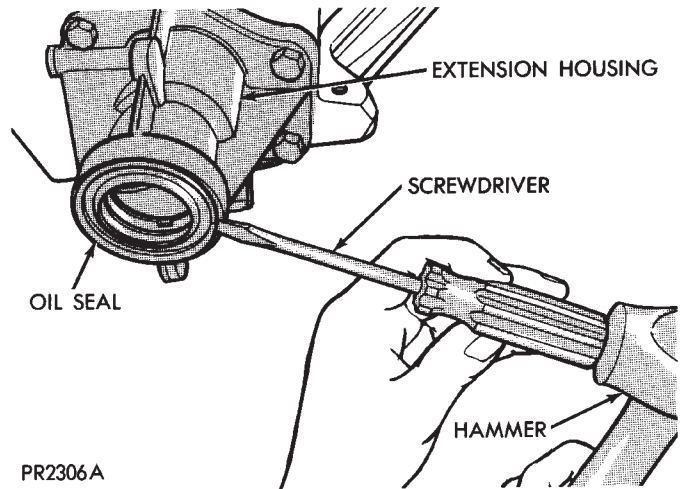

Fig. 1 Remove Extension Seal

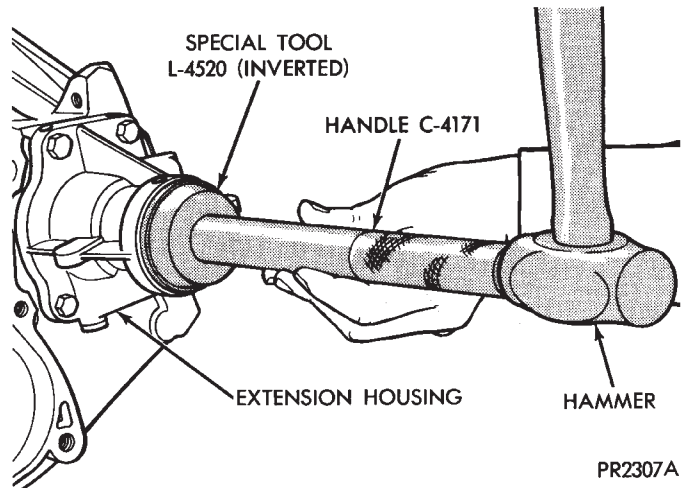

Fig. 2 Install New Seal Into Extension

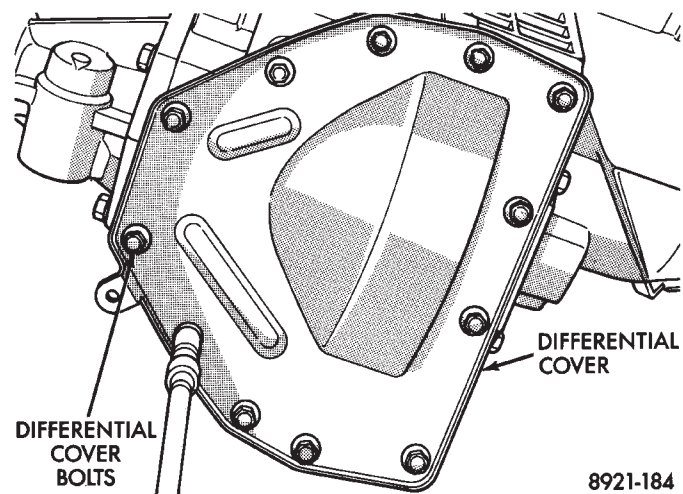

Fig. 3 Differential Cover Bolts

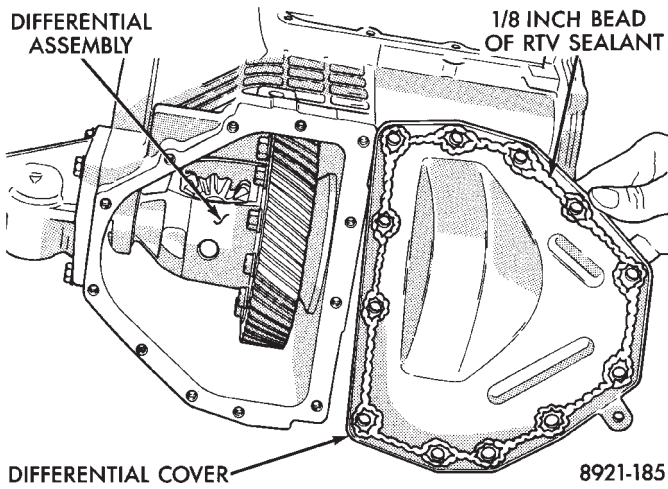

Fig. 4 Remove or Install Differential Cover

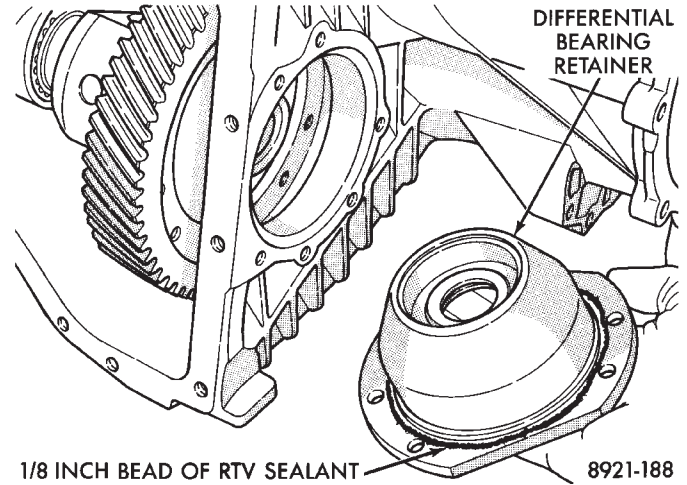

Fig. 7 Differential Bearing Retainer

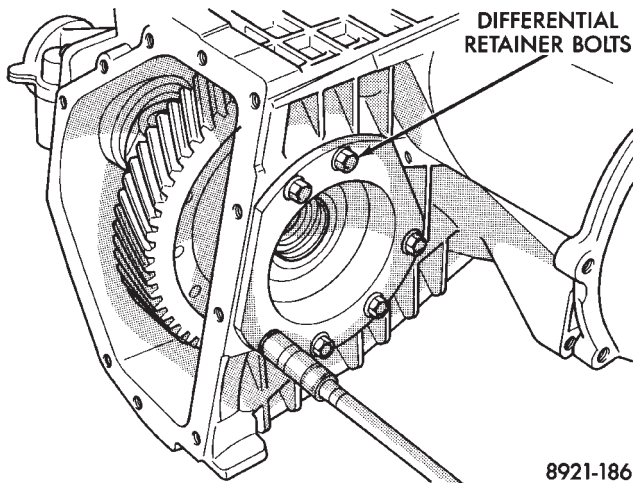

Fig. 5 Differential Retainer Bolts

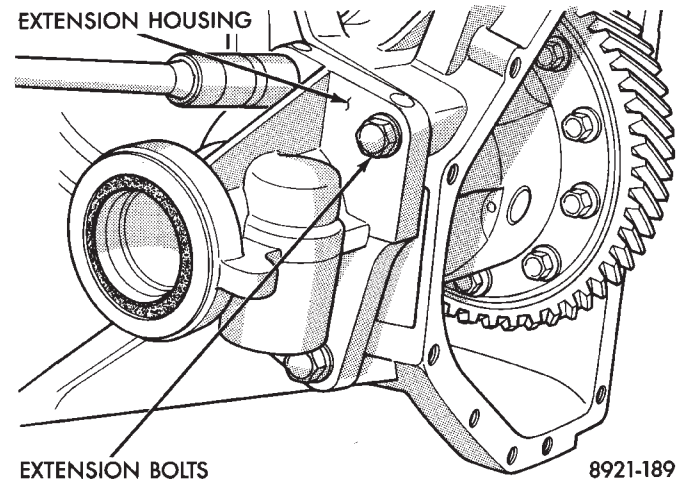

Fig. 8 Extension Bolts (Front Wheel Drive Vehicles)

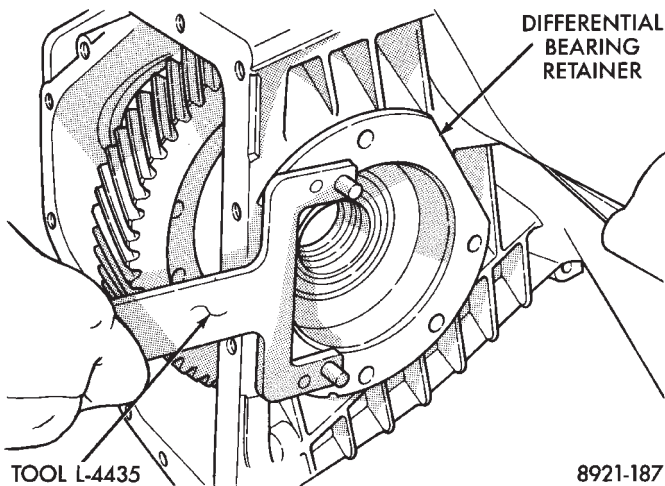

Fig. 6 Remove or Install Bearing Retainer

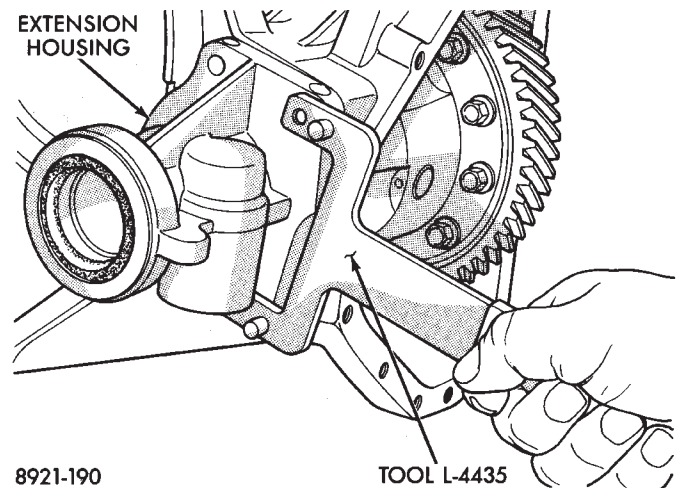

Fig. 9 Remove or Install Extension (Front Wheel Drive vehicles)

CAUTION: Vehicles equipped with All Wheel Drive have a retainer plate instead of an extension housing. Remove retainer plate bolts to remove retainer plate. Disregard Fig. 8, 9 and 10 on vehicles equipped with All Wheel Drive.

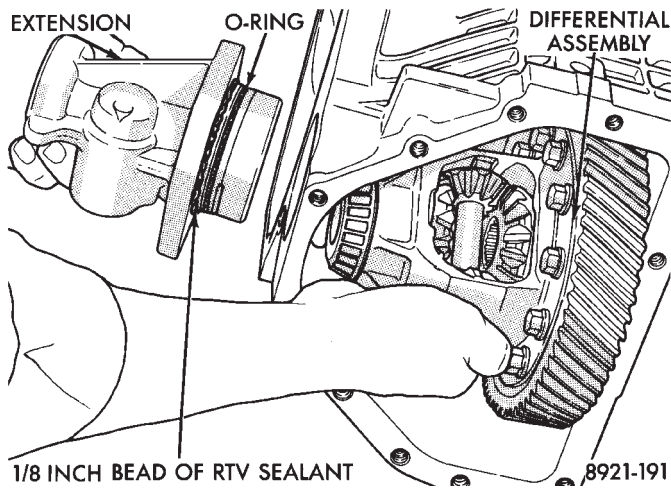

Fig. 10 Differential and Extension (Front Wheel Drive Vehicles)

CAUTION: Vehicles equipped with All Wheel Drive use a larger differential bearing on the retainer plate side of the differential assembly. Be sure to use the correct special tools when removing or installing the differential bearing.

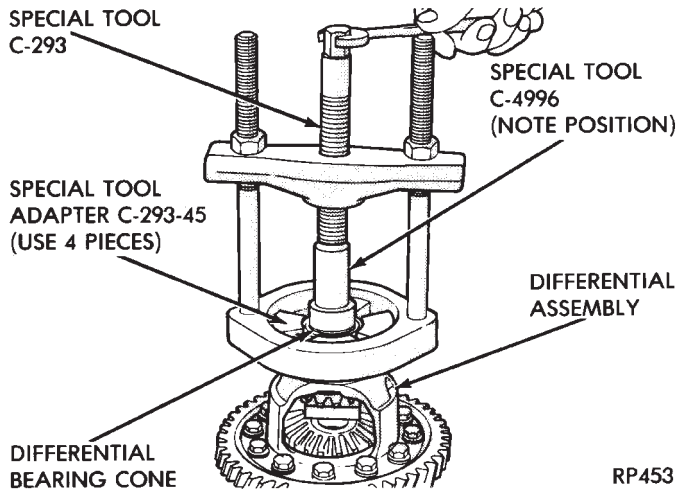

Fig. 11 Remove Differential Bearing Cone (Front Wheel Drive)

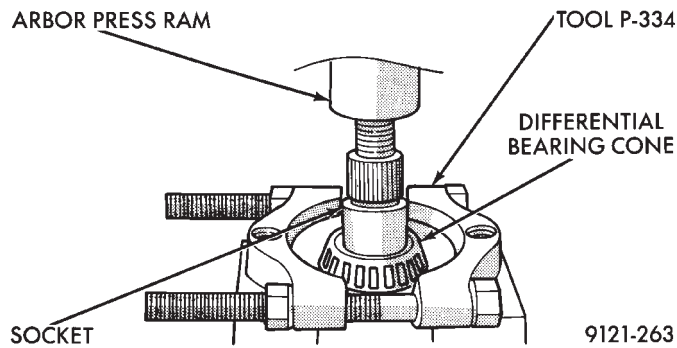

Fig. 12 Remove Differential Bearing Cone (All Wheel Drive)

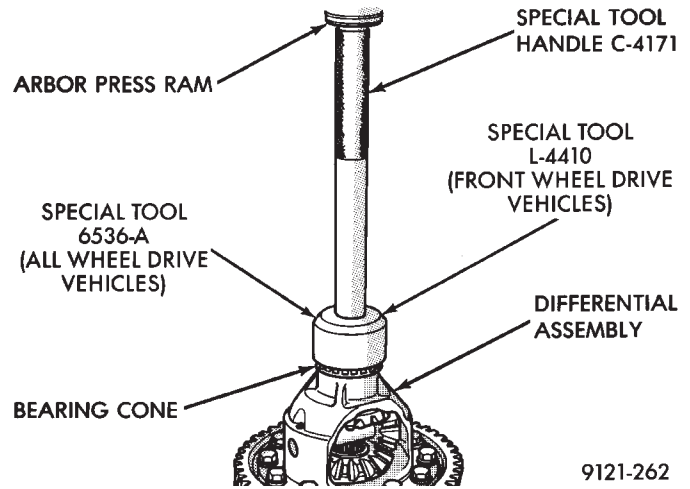

Fig. 13 Install Differential Bearing Cone

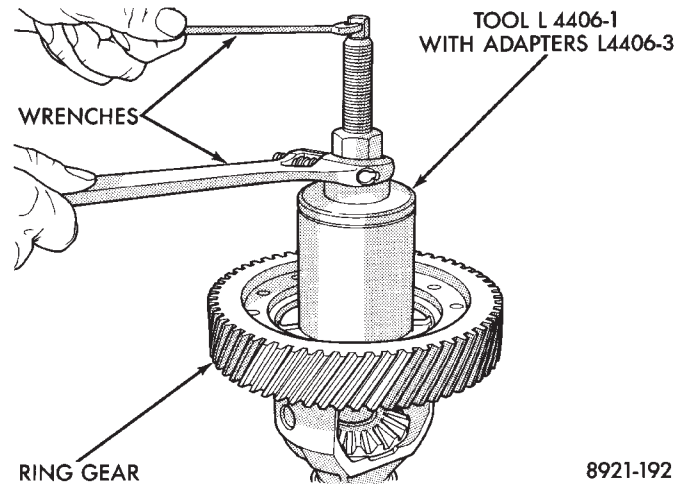

Fig. 14 Remove Differential Bearing Cone (All)

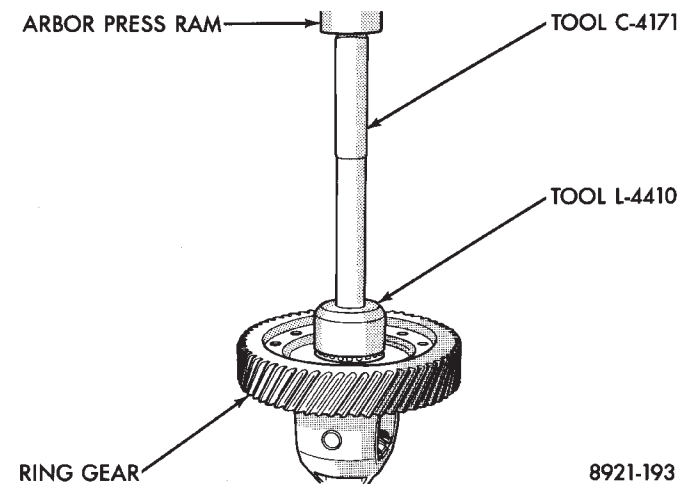

Fig. 15 Install Differential Bearing Cone (All)

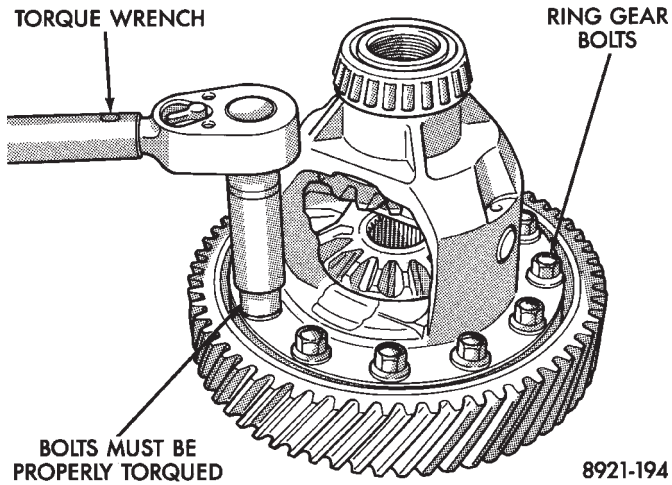

Fig. 16 Torque New Ring Gear Bolts to 95 Nm (70 Ft. Lbs.)

CAUTION: Always install NEW ring gear bolts. Bolts must be properly torqued.

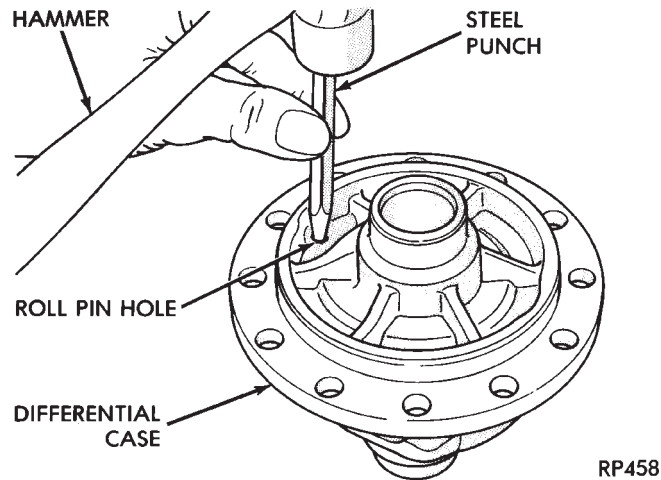

Fig. 17 Remove Pinion Shaft Roll Pin

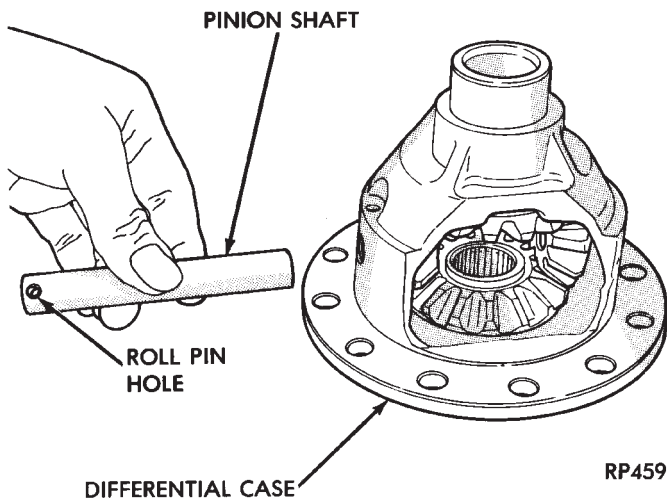

Fig. 18 Remove or Install Pinion Shaft

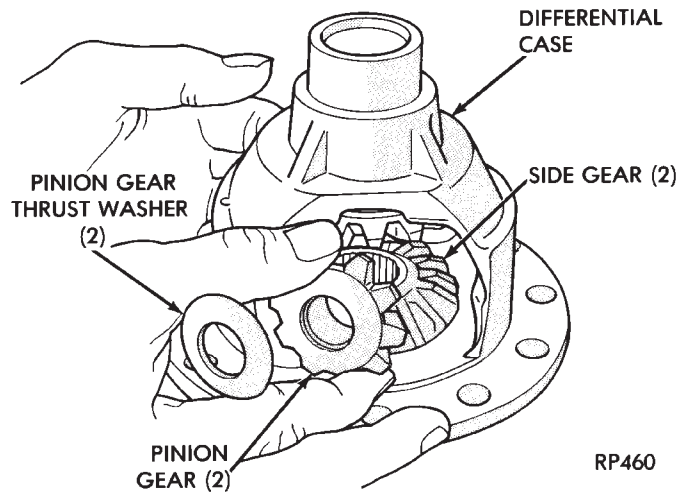

Fig. 19 Remove or Install Pinion Gears, Side Gears, and Tabbed Thrust Washers, by Rotating Pinion Gears to Opening in Differential Case

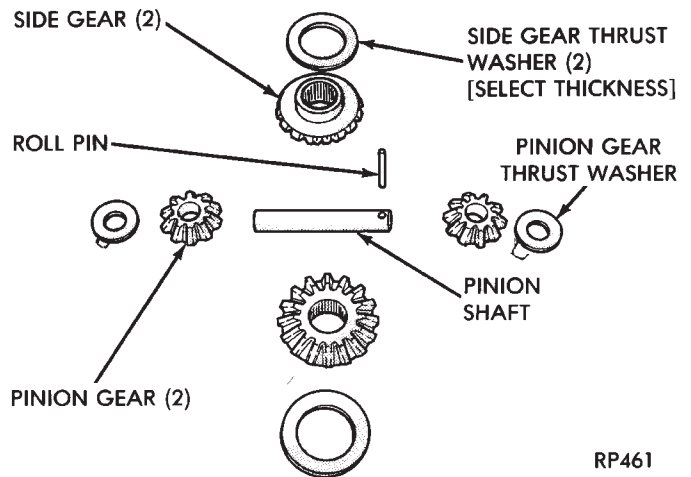

Fig. 20 Differential Gears

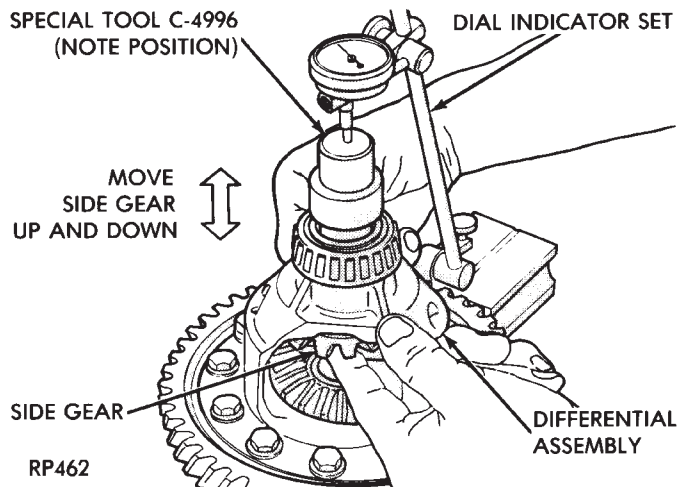
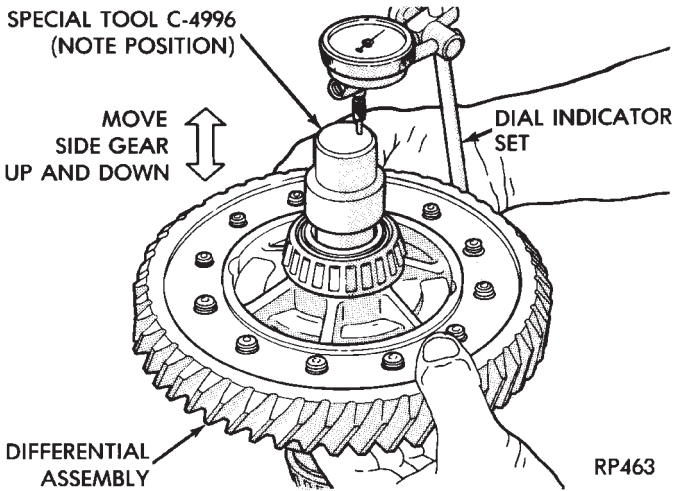

Fig. 21 Checking Side Gear End Play

CAUTION: Side gear end play must be within .001 to .013 inch.



Four select thrust washers are available: .032, .037, .042, and .047 inch.



RP463

Fig. 22 Checking Side Gear End Play

CAUTION: Side gear end play must be within .001 to .013 inch.

Four select thrust washers are available: .032, .037, .042, and .047 inch.

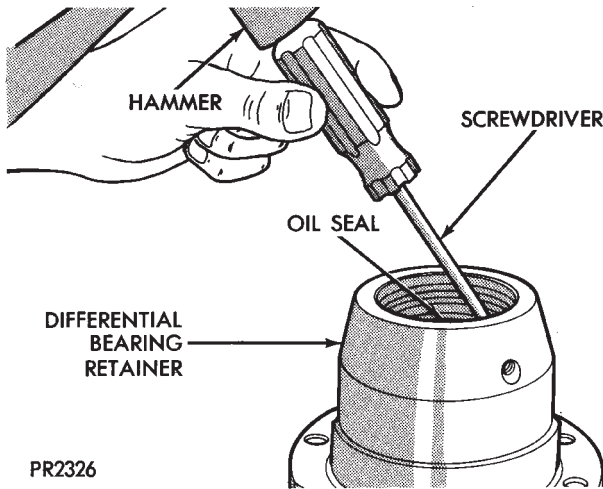

PR2326

Fig. 23 Remove Oil Seal

DETERMINING SHIM THICKNESS

Shim thickness need only be determined if any of the following parts are replaced:

- Transaxle case
- Differential carrier
- Differential bearing retainer
- Extension housing
- Differential bearing cups and cones

Refer to "Bearing Adjustment Procedure" in rear of this section to determine proper shim thickness for correct bearing preload and proper bearing turning torque.

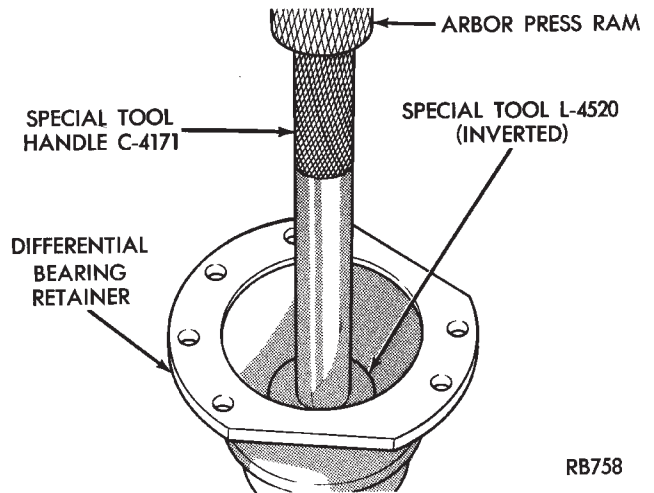

RB758

Fig. 24 Install New Oil Seal

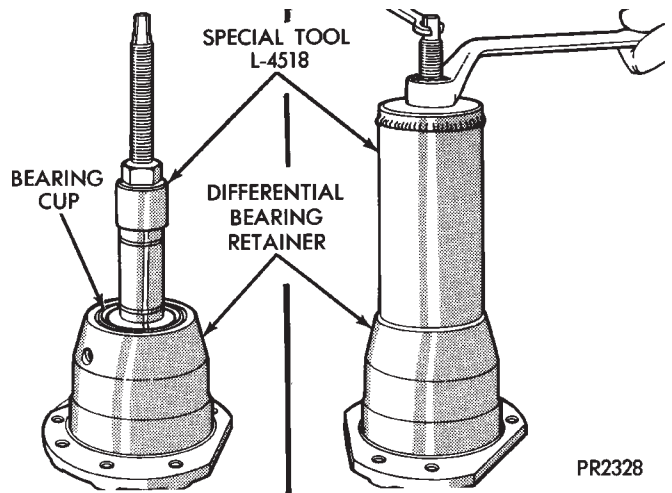

PR2328

Fig. 25 Remove Bearing Cup

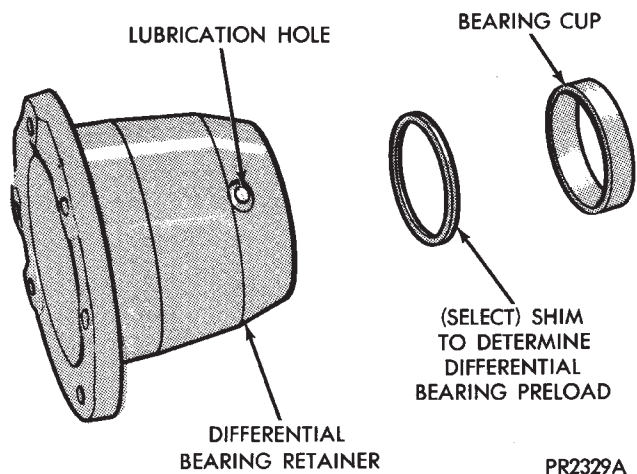

PR2329A

Fig. 26 Differential Bearing Retainer

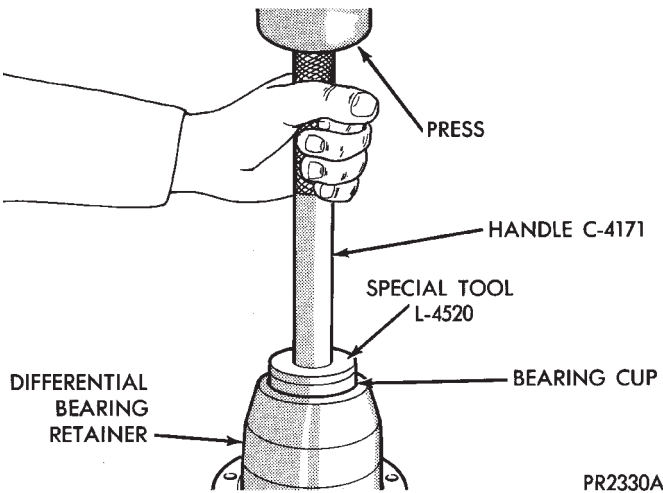

Fig. 27 Install Bearing Cup

When rebuilding, reverse the above procedure.

Remove old sealant before applying new Mo-par® Silicone Rubber Adhesive Sealant. Use Mo-par® Silicone Rubber Adhesive Sealant on retainer to seal retainer to case.

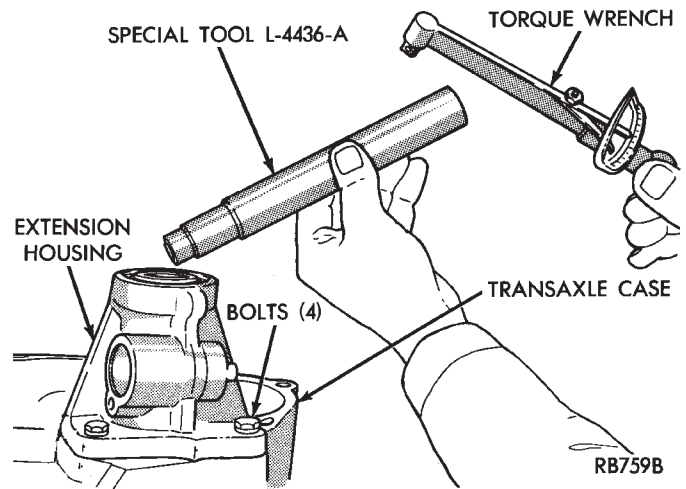

Fig. 29 Tool L-4436 and Torque Wrench

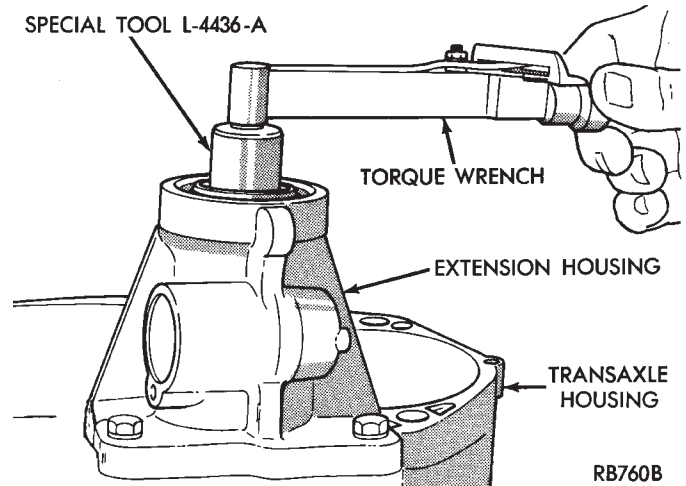

Fig. 30 Checking Differential Bearings Turning Torque

(2) Bearing cups and cones should be replaced if they show signs of pitting or heat distress.

If distress is seen on either the cup or bearing rollers, both cup and cone must be replaced.

Bearing end play and drag torque specifications must be maintained to avoid premature bearing failures.

Used (original) bearing may lose up to 50% of the original drag torque after break-in.

All bearing adjustments must be made with no other component interference or gear intermesh, except the transfer gear bearing.

Oil all bearings before checking turning torque.

OUTPUT GEAR BEARING

With output gear removed:

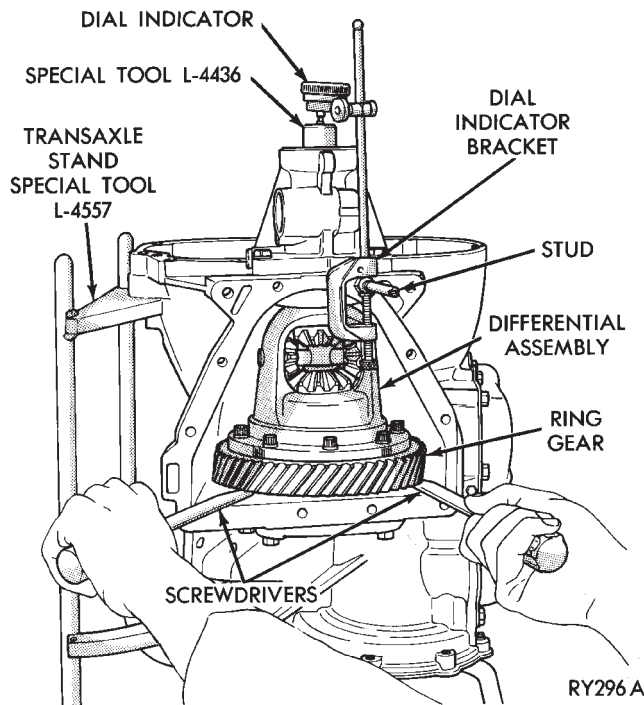

Fig. 28 Checking Differential End Play

BEARING ADJUSTMENT PROCEDURES

GENERAL RULES ON SERVICING BEARINGS

(1) Take extreme care when removing and in stalling bearing cups and cones. **Use only an arbor press for installation**, as a hammer may not properly align the bearing cup or cone. Burrs or nicks on the bearing seat will give a false end play reading, while gauging for proper shims. Improperly seated bearing cup and cones are subject to low-mileage failure.



(1) Install a 4.50 mm (0.177 inch) gauging shim on the rear carrier assembly hub, using grease to hold the shim in place.

(2) Install output gear and bearing assembly. Torque to 271 N•m (200 ft. lbs.).

(3) To measure bearing end play:

(a) Attach Tool L-4432 to the gear.

(b) Push and pull the gear while rotating back and forth to insure seating of the bearing rollers.

(c) Using a dial indicator, mounted to the transaxle case, measure output gear end play.

(4) Once bearing end play has been determined, refer to the output gear bearing shim chart for the required shim to obtain proper bearing setting.

(5) Use Tool 6259 to remove the retaining nut and washer. To remove the output gear, use Tool L-4407.

(6) Remove the gauging shim and install the proper shim. Use grease to hold the shim in place. Install the output gear and bearing assembly.

(7) Install the retaining nut and washer and torque to 271 N•m (200 ft. lbs.).

(8) Using an inch-pound torque wrench, check the turning torque. **The torque should be between 3 and 8 inch-pounds.**

If the turning torque is too high, install a .04 mm (.0016 inch) thicker shim. If the turning torque is too low, install a .04 mm (.0016 inch) thinner shim. Repeat until the proper turning torque is 3 to 8 inch pounds.

OUTPUT GEAR BEARING SHIM CHART

End Play (with 4.50 mm gauging shim installed)		Required Shim	End Play (with 4.50 mm gauging shim installed)		Required Shim
mm	inch		mm	inch	
.05	.002	4.42	.53	.021	3.94
.08	.003	4.38	.56	.022	3.90
.10	.004	4.38	.58	.023	3.90
.13	.005	4.34	.61	.024	3.86
.15	.006	4.30	.64	.025	3.82
.18	.007	4.30	.66	.026	3.82
.20	.008	4.26	.69	.027	3.78
.23	.009	4.22	.71	.028	3.74
.25	.010	4.22	.74	.029	3.74
.28	.011	4.18	.76	.030	3.70
.30	.012	4.14	.79	.031	3.66
.33	.013	4.14	.81	.032	3.66
.36	.014	4.10	.84	.033	3.62
.38	.015	4.10	.86	.034	3.62
.41	.016	4.06	.89	.035	3.58
.43	.017	4.02	.91	.036	3.54
.46	.018	4.02	.94	.037	3.54
.48	.019	3.98	.97	.038	3.50
.51	.020	3.94			

Average conversion .04 mm = .0016 inch

9121-255

DIFFERENTIAL BEARING

(1) Remove the bearing cup from the differential bearing retainer using Tool L-4518, and remove the existing shim from under the cup.

(2) Install a .50 mm (.020 inch) gauging shim and reinstall the bearing cup into the retainer. Use an arbor press to install the cup.

Oil Baffle is not required when making shim selection.

(3) Install the bearing retainer into the case and torque bolts to 28 N•m (250 in. lbs.).

(4) Position the transaxle assembly vertically on the support stand and install Tool C-4995 into side gear.

(5) Rotate the differential at least one full revolution to ensure the tapered roller bearings are fully seated.

(6) Attach a dial indicator to the case and zero the dial indicator. Place the indicator tip on the end of Tool

DIFFERENTIAL BEARING SHIM CHART

End Play (with .50 mm gauging shim installed)		Required Shim Combination	Total Thickness	
mm	inch		mm	inch
.0	.0	.50	.50	.020
.05	.002	.75	.75	.030
.10	.004	.80	.80	.032
.15	.006	.85	.85	.034
.20	.008	.90	.90	.035
.25	.010	.95	.95	.037
.30	.012	1.00	1.00	.039
.35	.014	1.05	1.05	.041
.40	.016	.50 + .60	1.10	.043
.45	.018	.50 + .65	1.15	.045
.50	.020	.50 + .70	1.20	.047
.55	.022	.50 + .75	1.25	.049
.60	.024	.50 + .80	1.30	.051
.65	.026	.50 + .85	1.35	.053
.70	.027	.50 + .90	1.40	.055
.75	.029	.50 + .95	1.45	.057
.80	.031	.50 + 1.00	1.50	.059
.85	.033	.50 + 1.05	1.55	.061
.90	.035	1.00 + .60	1.60	.063
.95	.037	1.00 + .65	1.65	.065
1.00	.039	1.00 + .70	1.70	.067
1.05	.041	1.00 + .75	1.75	.069
1.10	.043	1.00 + .80	1.80	.071
1.15	.045	1.00 + .85	1.85	.073
1.20	.047	1.00 + .90	1.90	.075
1.25	.049	1.00 + .95	1.95	.077
1.30	.051	1.00 + 1.00	2.00	.079
1.35	.053	1.00 + 1.05	2.05	.081
1.40	.055	1.05 + 1.05	2.10	.083

9121-256

L-4436.

(7) Place a large screwdriver to each side of the ring gear and lift. Check the dial indicator for the amount of end play.

CAUTION: Do not damage the transaxle case and/or differential cover sealing surface.

TRANSFER BEARING SHIM CHART

(8) When the end play has been determined, refer to the Differential Bearing Shim Chart for the correct shim combination to obtain the proper bearing setting.

(9) Remove the differential bearing retainer. Remove the bearing cup and the .50 mm (.020 inch) gauging shim.

(10) Install the proper shim combination under the bearing cup. Make sure the oil baffle is installed properly in the bearing retainer, below the bearing shim and cup.

(11) Install the differential bearing retainer. Seal the retainer to the housing with Mopar® Silicone Rubber Adhesive Sealant and torque bolts to 28 N•m (250 in. lbs.).

(12) Using Tool C-4995 and an inch-pound torque wrench, check the turning torque of the differential. **The turning torque should be between 5 and 18 inch-pounds.**

If the turning torque is too high, install a .05 mm (.002 inch) thinner shim. If the turning torque is too low, install a .05 mm (.002 inch) thicker shim. Repeat until 5 to 18 inch-pounds turning torque is obtained.

TRANSFER SHAFT BEARING

(1) Use Tool 6259 to remove the retaining nut and washer. Remove the transfer shaft gear using Tool L-4407.

(2) Install a 4.66 mm (.184 inch) gauging shim on the transfer shaft.

(3) Install transfer shaft gear and bearing assembly and torque the nut to 271 N•m (200 ft. lbs.).

(4) To measure bearing end play:

(a) Attach Tool L-4432 to the transfer gear.

(b) Mount a steel ball with grease into the end of the transfer shaft.

(c) Push and pull the gear while rotating back and forth to insure seating of the bearing rollers.

(d) Using a dial indicator, measure transfer shaft end play.

(5) Refer to the Transfer Bearing Shim Chart for the required shim combination to obtain the proper bearing setting.

(6) Use Tool 6259 to remove the retaining nut and washer. Remove the transfer shaft gear using Tool L-4407.

End Play (with 4.66 mm gauging shim installed)		Required Shim	End Play (with 4.66 mm gauging shim installed)		Required Shim
mm	inch		mm	inch	
.05	.002	4.66	.79	.031	3.90
.08	.003	4.62	.81	.032	3.90
.10	.004	4.58	.84	.033	3.86
.13	.005	4.58	.86	.034	3.82
.15	.006	4.54	.89	.035	3.82
.18	.007	4.50	.91	.036	3.78
.20	.008	4.50	.94	.037	3.74
.23	.009	4.46	.97	.038	3.74
.25	.010	4.46	.99	.039	3.70
.28	.011	4.42	1.02	.040	3.66
.30	.012	4.38	1.04	.041	3.66
.33	.013	4.38	1.07	.042	3.62
.36	.014	4.34	1.08	.043	3.62
.38	.015	4.30	1.12	.044	3.58
.41	.016	4.30	1.14	.045	3.54
.43	.017	4.26	1.17	.046	3.54
.46	.018	4.22	1.19	.047	3.50
.48	.019	4.22	1.22	.048	3.46
.50	.020	4.18	1.24	.049	3.46
.53	.021	4.18	1.27	.050	3.42
.56	.022	4.14	1.30	.051	3.38
.58	.023	4.10	1.32	.052	3.38
.61	.024	4.10	1.35	.053	3.34
.64	.025	4.06	1.37	.054	3.34
.66	.026	4.02	1.40	.055	3.30
.69	.027	4.02	1.42	.056	3.26
.71	.028	3.98	1.45	.057	3.26
.74	.029	3.94	1.47	.058	3.22
.76	.030	3.94			

9121-2

(7) Remove the gauging shim and install the correct shim. Install the transfer gear and bearing assembly.

(8) Install the retaining nut and washer and torque to 271 N•m (200 ft. lbs.). **Measure transfer shaft end play, end play should be .05 to .10 mm (.002 to .004 inch).**

(9) Measure bearing end play as outlined in Step (4). End play should be between .05 mm and .10 mm (.002 to .004 inch).

If end play is too high, install a .04 mm (.0016 inch) thinner shim. If end play is too low, install a .04 mm (.0016 inch) thicker shim combination. Repeat until .05 to .10 mm (.002 to .004 inch) end play is obtained.

BEARING SHIM CHART

Shim Thickness		Bearing Usage		
mm	inch	Output Gear	Transfer Shaft	Differential
3.22	.127	X	X	—
3.26	.128	X	X	—
3.30	.130	X	X	—
3.34	.132	X	X	—
3.38	.133	X	X	—
3.42	.135	X	X	—
3.46	.136	X	X	—
3.50	.138	X	X	—
3.54	.139	X	X	—
3.58	.141	X	X	—
3.62	.143	X	X	—
3.66	.144	X	X	—
3.70	.146	X	X	—
3.74	.147	X	X	—
3.78	.149	X	X	—
3.82	.150	X	X	—
3.86	.152	X	X	—
3.90	.154	X	X	—
3.94	.155	X	X	—
3.98	.157	X	X	—
4.02	.158	X	X	—
4.06	.160	X	X	—
4.10	.161	X	X	—
4.14	.163	X	X	—
4.18	.165	X	X	—
4.22	.166	X	X	—
4.26	.168	X	X	—
4.30	.169	X	X	—
4.34	.171	X	X	—
4.38	.172	X	X	—
4.42	.174	X	X	—
4.46	.175	X	X	—
4.50	.177	X*	X	—
4.54	.178	X	X	—
4.58	.180	X	X	—
4.62	.182	X	X	—
4.66	.183	X	X*	—
0.50	.020	—	—	X*
0.55	.022	—	—	X
0.60	.024	—	—	X
0.65	.026	—	—	X
0.70	.027	—	—	X
0.75	.029	—	—	X
0.80	.031	—	—	X
0.85	.033	—	—	X
0.90	.035	—	—	X
0.95	.037	—	—	X
1.00	.039	—	—	X
1.05	.041	—	—	X

* Also used as gauging shims

9121-1

ALL WHEEL DRIVE POWER TRANSFER UNIT (P.T.U.)

INDEX

	page		page
Fluid Leak Diagnosis	141	Power Transfer Unit Input Shaft End Seal	153
General Information	141	Power Transfer Unit Input Shaft Seal	146
Output Flange Shim Selection	150	Power Transfer Unit Outer Half Shaft Seal	155
Power Transfer Unit (P.T.U.)	142	Power Transfer Unit Output Seal	148
Power Transfer Unit End Cover Ball Bearing	155	Power Transfer Unit Rear Cover O-Ring	148
Power Transfer Unit End Cover—Reseal	145	Seal Identification	141
Power Transfer Unit Half Shaft Inner Seal	152	Transaxle Differential Carrier Seal	147
Power Transfer Unit Input Shaft Cover Seal	150		

GENERAL INFORMATION

The Power Transfer Unit (P.T.U.) is attached to a modified automatic transaxle case where the right half shaft extension housing would normally be located. The Transfer Unit provides the power to the rear wheels through a hypoid ring gear and pinion set.

The Power Transfer Unit is sealed from the transaxle and has its own oil sump. The Unit uses SAE 85W-90 gear lubricant and holds 1.15 liters (1.22 quarts).

The Power Transfer Unit fill plug is located on the end cover (Fig. 1). **Do not mistake the black plastic inspection plug located on the P.T.U. case for the fill plug.**

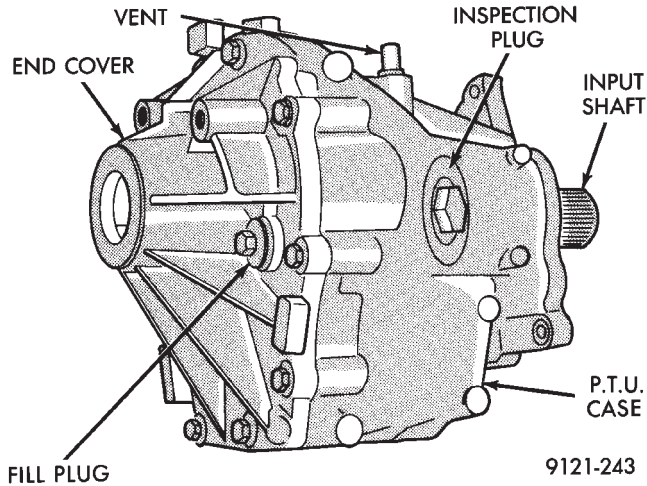

Fig. 1 Fill Plug Location

Service of the Power Transfer Unit is limited to the seals, gaskets and one ball bearing. If the ring gear and pinion, any tapered roller bearings, case, covers, or pinion carrier fail the entire unit must be replaced.

SEAL IDENTIFICATION

For accurate seal diagnosis and repair seal name and location is critical. Refer to figures 1, 2, 3 and 4 for appropriate seal name and location.

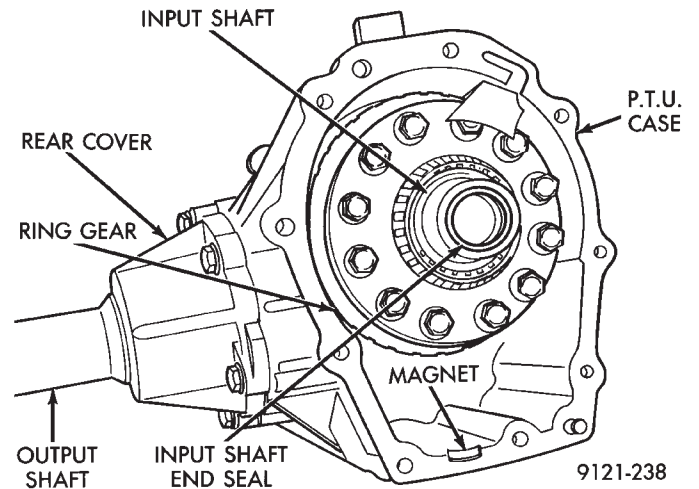

Fig. 1 Seal Location

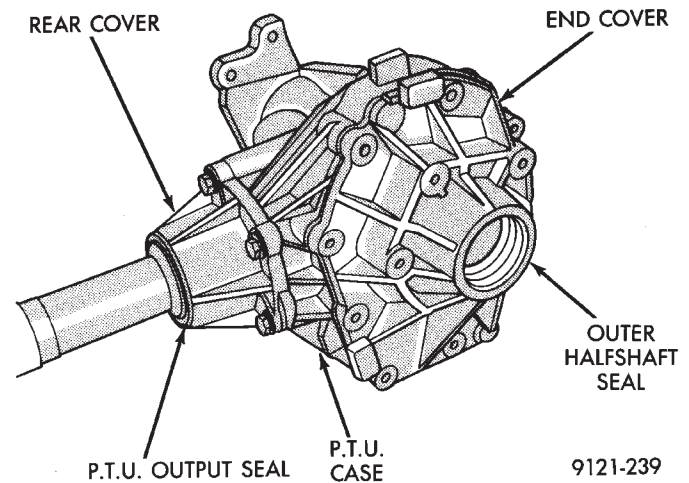

Fig. 2 Seal Location

FLUID LEAK DIAGNOSIS

When diagnosing fluid leaks on the Power Transfer Unit assembly two weep holes are provided to diagnose certain seal leaks. These holes are located on the bottom side of the assembly (Fig. 5).

If fluid leak is detected from either weep hole, seal replacement is necessary. **Do not attempt to repair**

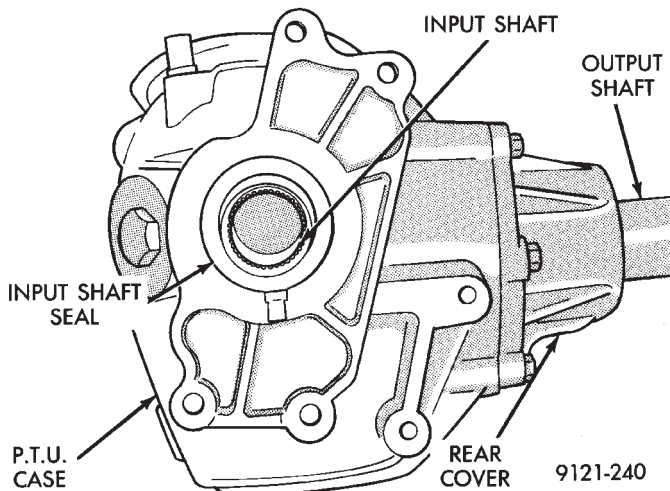

Fig. 3 Seal Location

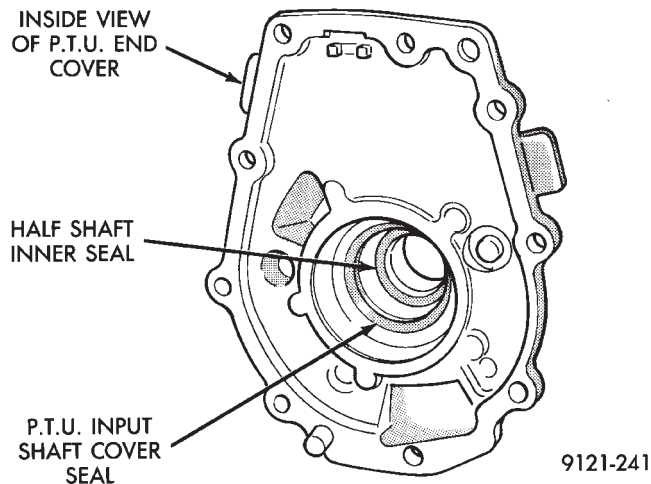

Fig. 4 Seal Location

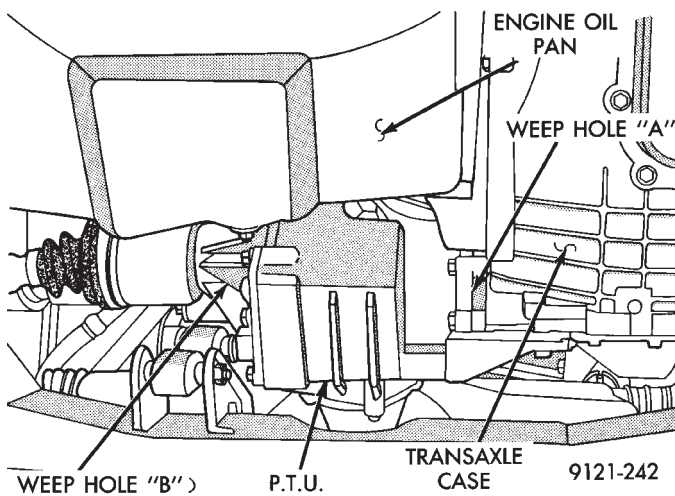

Fig. 5 Weep Hole Locations

the leak by sealing weep holes, they must be kept clear of sealants for proper seal operation.

If fluid is leaking from weep hole "A" (Fig. 5) the type of fluid leaking will determine which seal needs to be replaced. If the fluid leaking is red in color (transmis-

sion fluid) this indicates that the Transmission differential carrier seal should be replaced. If the fluid leaking is light brown (gear lube) this indicates that the Power Transfer Unit input seal should be replaced. For replacement of these seals refer to Power Transfer Unit Service Procedures.

If fluid is leaking from weep hole "B" (Fig. 5) the type of fluid leaking will determine which seal is leaking. If the fluid leaking is red in color (transmission fluid) this indicates that the input shaft end seal should be replaced. If the fluid leaking is light brown (gear lube) this indicates that the half shaft inner seal and P.T.U. input shaft cover seal should be replaced. For replacement of these seals refer to Power Transfer Unit Service Procedures.

Before condemning any seal or gasket be sure that the rear rocker arm cover on the engine is not the cause of the oil leak. Oil leaking from the rocker arm cover is easily mistaken for a leaking Power Transfer Unit.

POWER TRANSFER UNIT (P.T.U.)

REMOVAL AND INSTALLATION

- (1) Raise vehicle and remove front wheels.
- (2) Remove propeller shaft assembly.

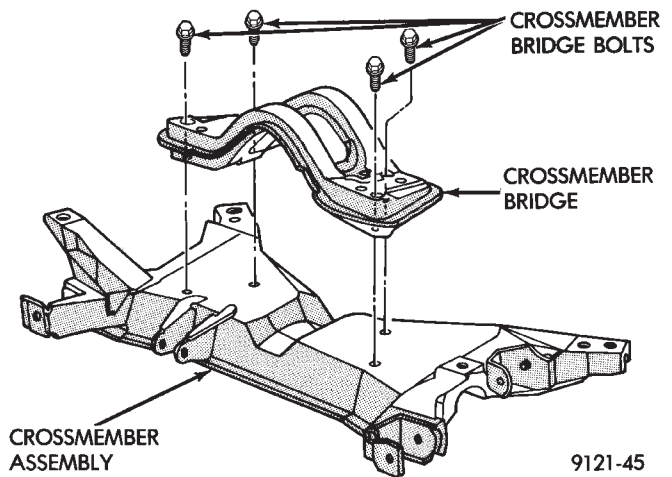

Fig. 1 Remove Cross Member Bridge Bolts

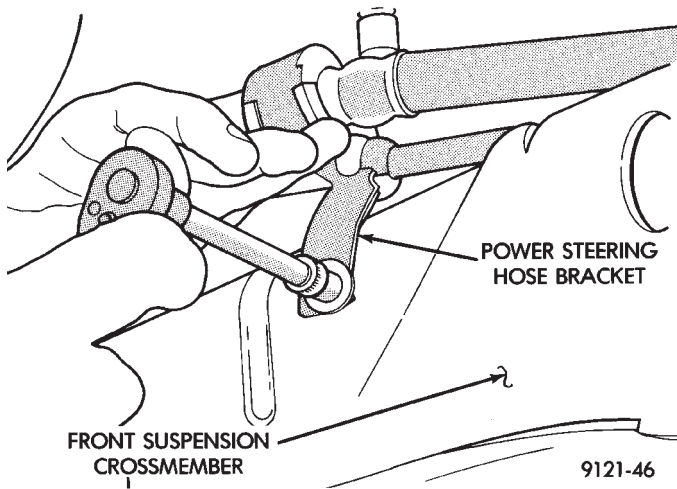

Fig. 2 Remove Power Steering Hose Bracket

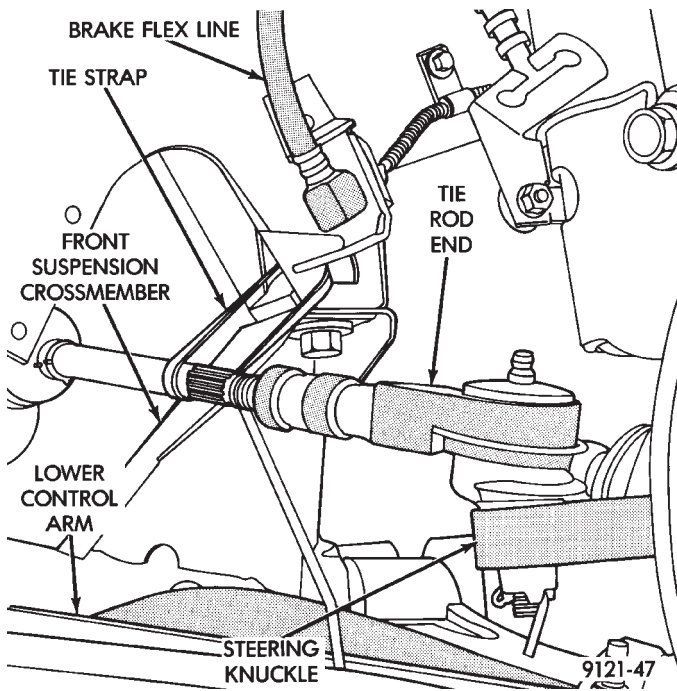

Fig. 3 Secure Rack and Pinion to Frame Rail

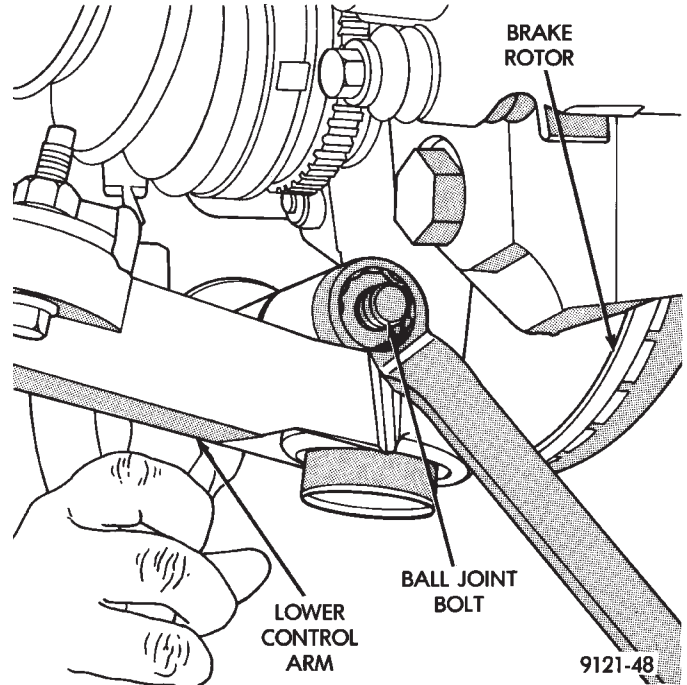

Fig. 4 Remove Ball Joint Bolt (Right and Left Side)

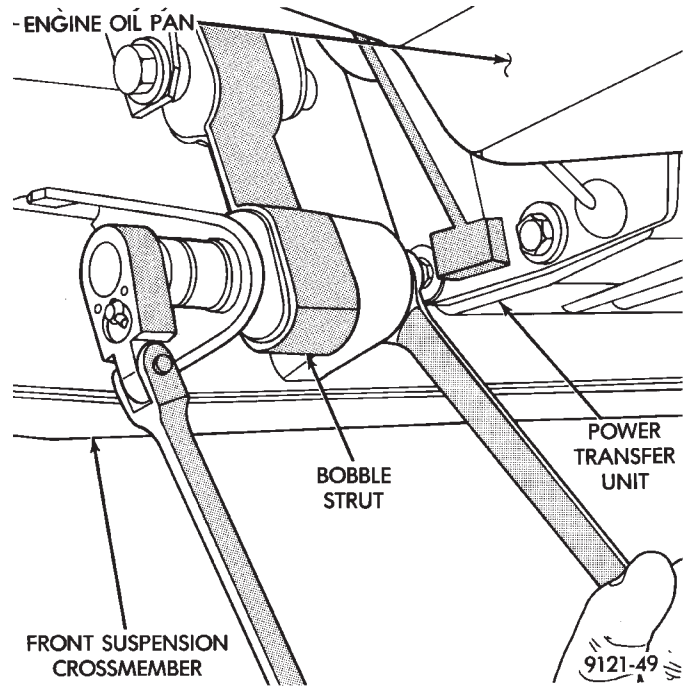

Fig. 5 Remove Lower Bobble Strut Bolt

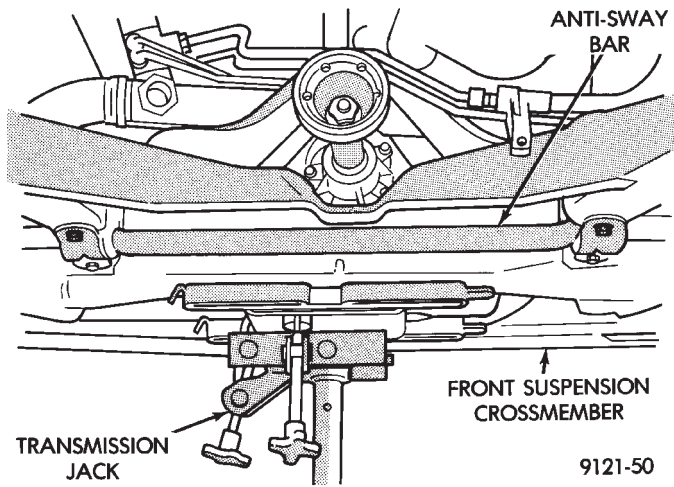

Fig. 6 Support Crossmember with Transmission Jack

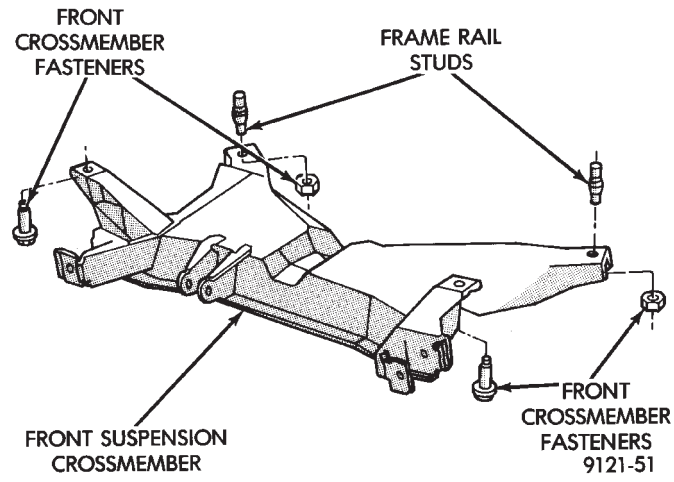

Fig. 7 Remove Front Suspension Crossmember Fasteners

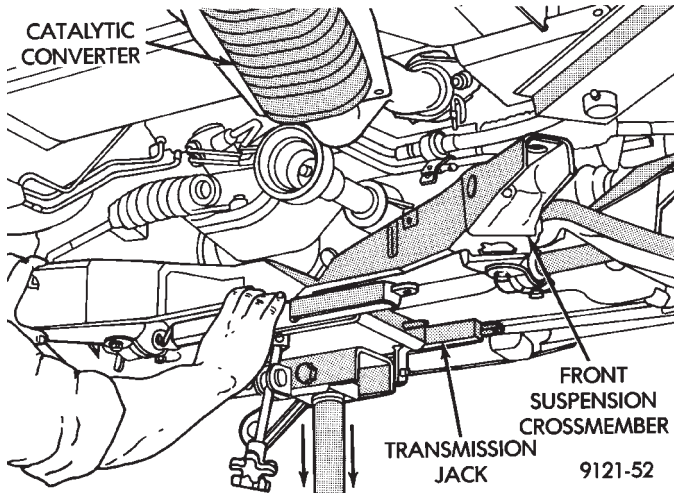

Fig. 8 Lower Crossmember Assembly and Remove
CAUTION: A certain amount of oil will drain out of the transaxle when the drive shaft is removed.

Remove right front drive shaft. Refer to "Suspension, Group 2" to remove or install wheel hub nut and right drive shaft.

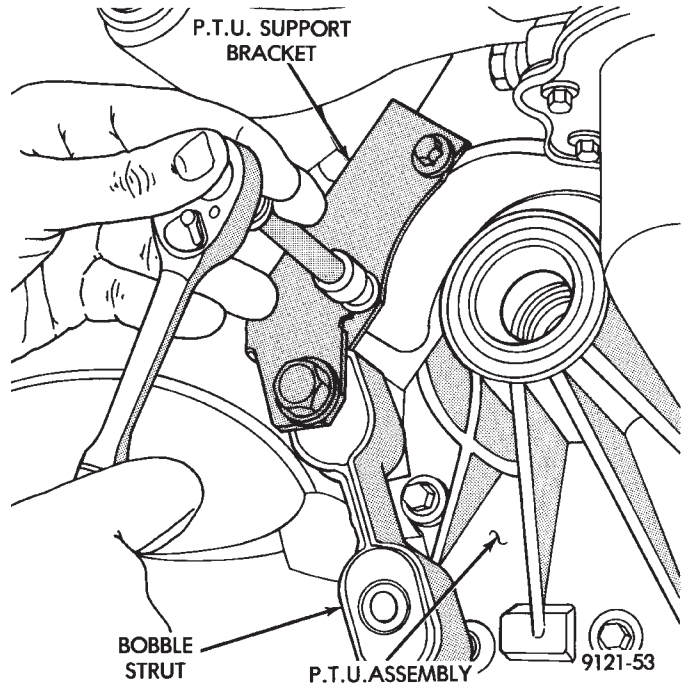

Fig. 9 Remove P.T.U Support Bracket and Bobble Strut Assembly

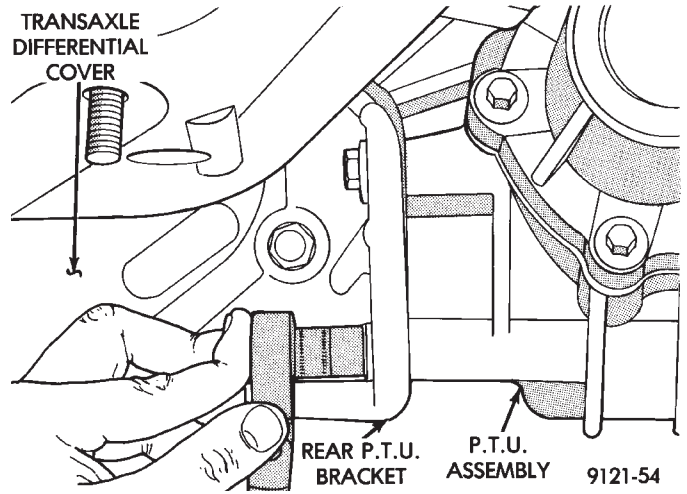

Fig. 10 Remove Rear P.T.U Brace Bolts

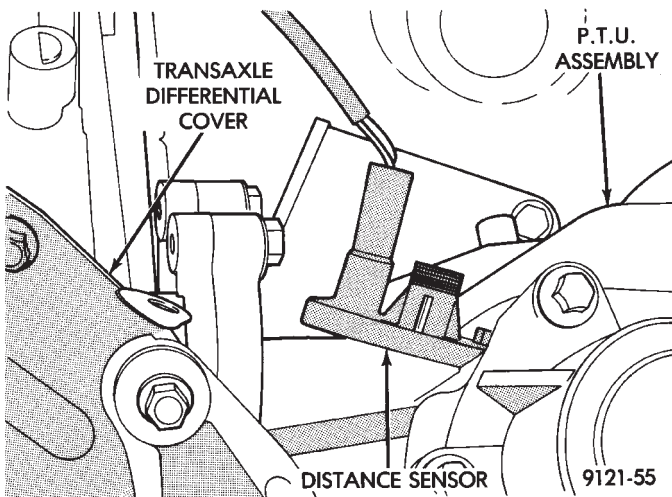

Fig. 11 Remove Distance Sensor from P.T.U.

Remove P.T.U. remote vent from left engine mount.

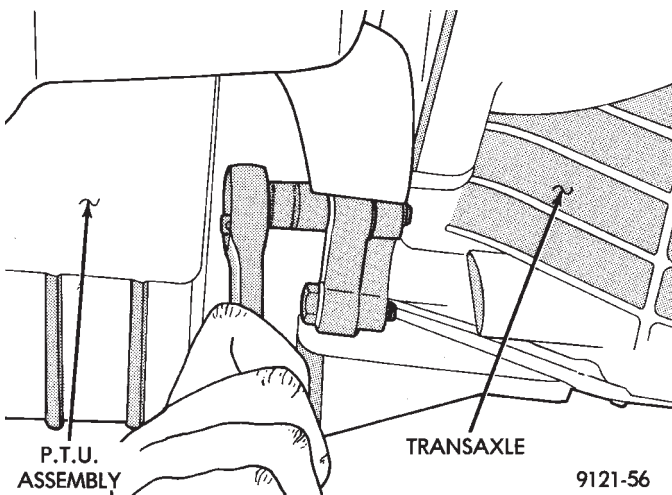

Fig. 12 Remove P.T.U. Mounting Bolts (4)

**Remove P.T.U. assembly from vehicle.
To Install, Reverse Removal Procedure.**

POWER TRANSFER UNIT END COVER—RESEAL

The Power Transfer Unit must be removed from the vehicle to perform this operation. Refer to Power Transfer Unit Removal in this section for procedures.

- (1) Remove P.T.U. end cover bolts (Fig. 13).
- (2) Gently tap on end cover ears with a hammer to separate end cover from the case (Fig. 14).
- (3) Clean and inspect sealer surfaces.
- (4) Apply Mopar® Gasket Maker, Loctite Gasket Eliminator No.518 or equivalent to sealing surfaces.
- (5) Reinstall cover and tighten bolts to 28 N•m (250 in. lbs.) in the sequence shown in figure 15. Retighten first bolt after all others are tight.

CAUTION: When end cover is installed be careful not to damage the P.T.U. Input Shaft Cover Seal.

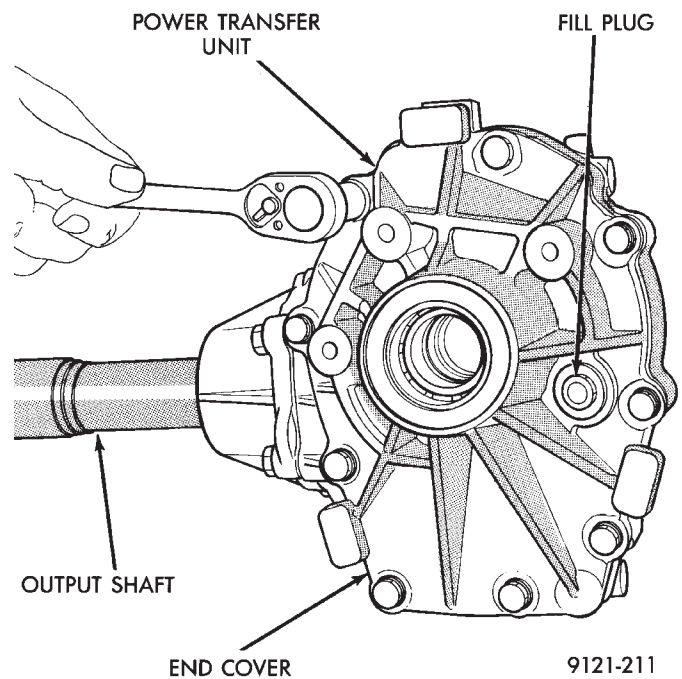

Fig. 13 P.T.U. End Cover Bolts

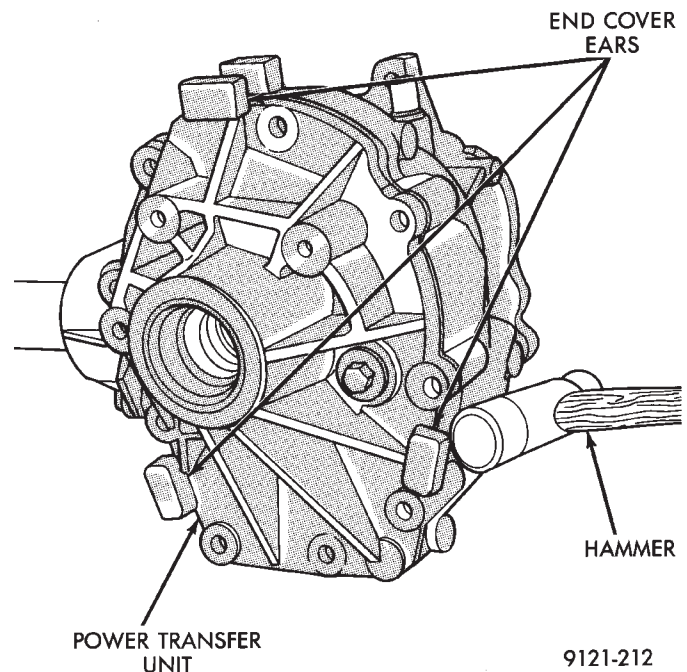

Fig. 14 End Cover Removal

- (6) Reinstall P.T.U. into vehicle.
- (7) Check and fill fluids as required.

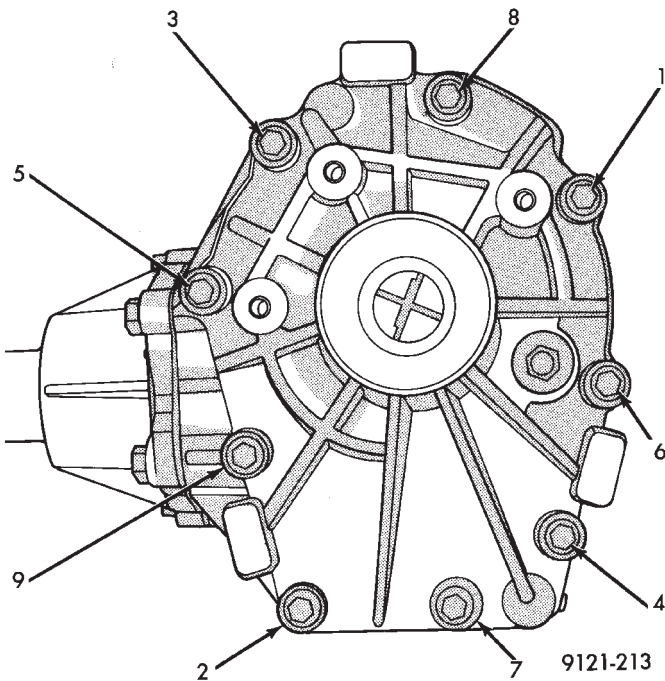

Fig. 15 Bolt Tightening Sequence

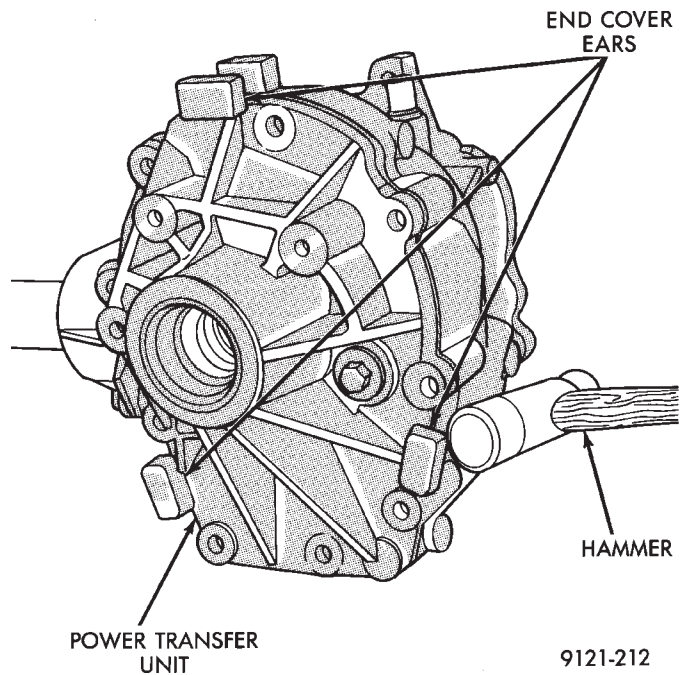

Fig. 2 End Cover Removal

POWER TRANSFER UNIT INPUT SHAFT SEAL

The Power Transfer Unit must be removed from the vehicle to service this seal. Refer to Power Transfer Unit Removal in this section for procedures.

REMOVAL

- (1) Remove P.T.U. end cover bolts (Fig. 1).

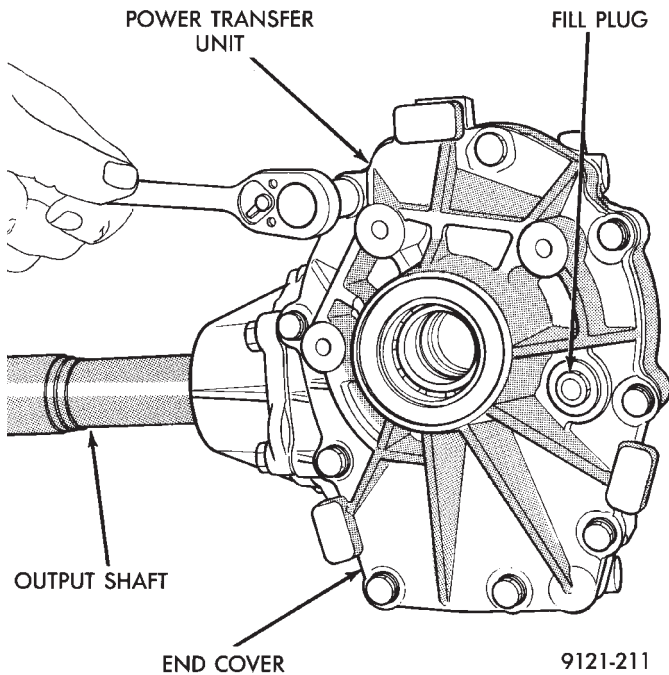

Fig. 1 P.T.U. End Cover Bolts

- (2) Gently tap on end cover ears to separate cover from case (Fig. 2).

- (3) Remove ring gear oil slinger (Fig. 3).

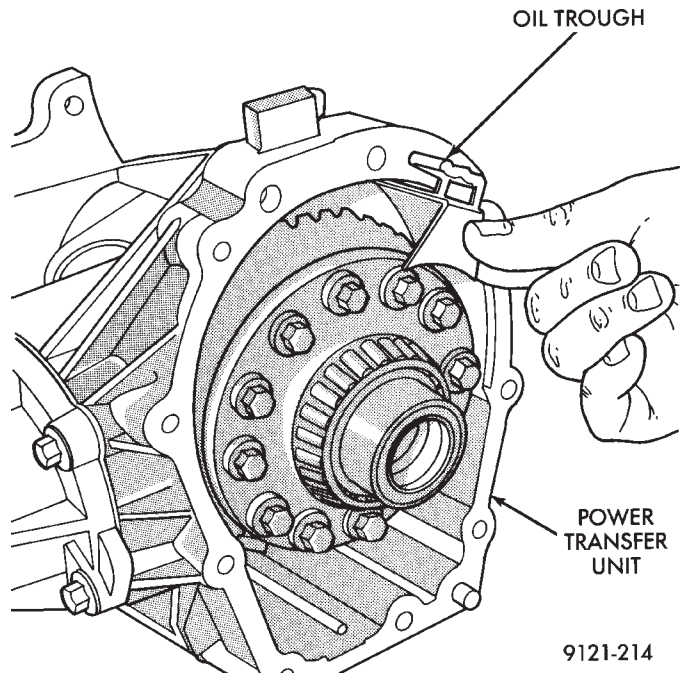

Fig. 3 Oil Trough

- (4) Remove input shaft and ring gear from case (Fig. 4).

- (5) Use Special Tool No. 7794-A (seal puller) to remove seal (Fig. 5).

INSTALLATION

- (1) Clean and inspect seal area.

- (2) Lay housing on bench and install new seal with seal driver C-4657 and handle C-4171 (Fig. 6). The seal must be installed with the spring side facing to-

wards the ring gear. Drive the seal in until it bottoms against the case shoulder.

- (3) Install input shaft.
- (4) Install oil trough.
- (5) Apply Mopar® Gasket Maker, Loctite Gasket Eliminator No. 518 or equivalent to sealing surfaces of end cover and reinstall. Tighten bolts to 28 N•m (250 in. lbs.)

CAUTION: When end cover is installed be careful not to damage the P.T.U. Input Shaft Cover Seal.

- (6) Reinstall P.T.U. assembly into vehicle.
- (7) Check and fill fluids as required.

TRANSAXLE DIFFERENTIAL CARRIER SEAL

The Power Transfer Unit must be removed from the vehicle to replace this seal.

REMOVAL

- (1) Remove P.T.U. from vehicle.

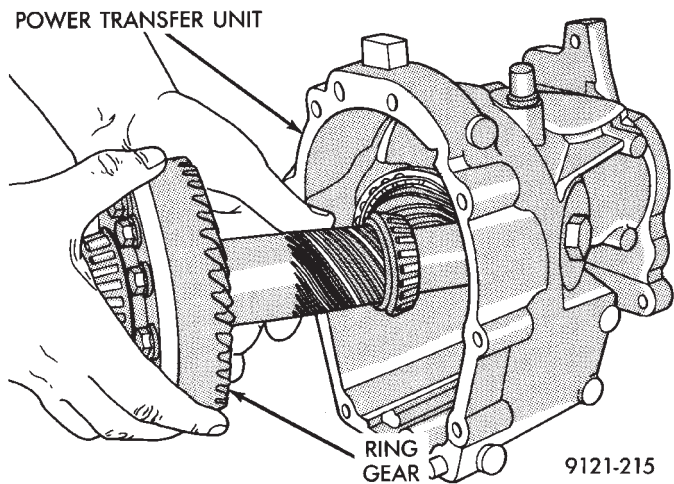

Fig. 4 Input Shaft and Ring Gear Removal

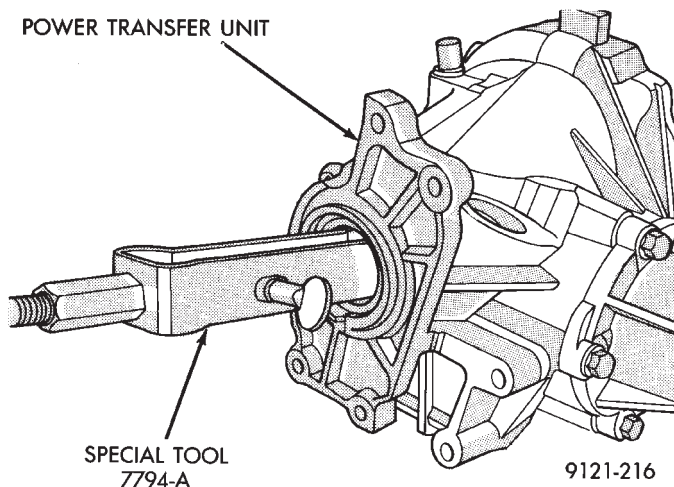

Fig. 5 Seal Removal

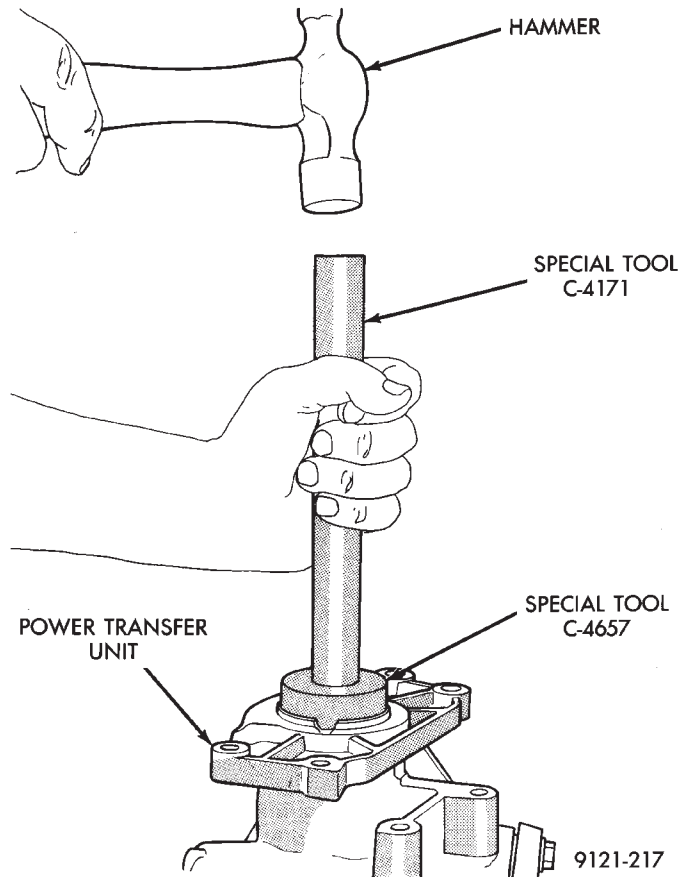

Fig. 6 Seal Installation

- (2) Use a pry bar to remove seal from retainer plate (Fig. 7). Be careful not to damage seal journal when removing seal.

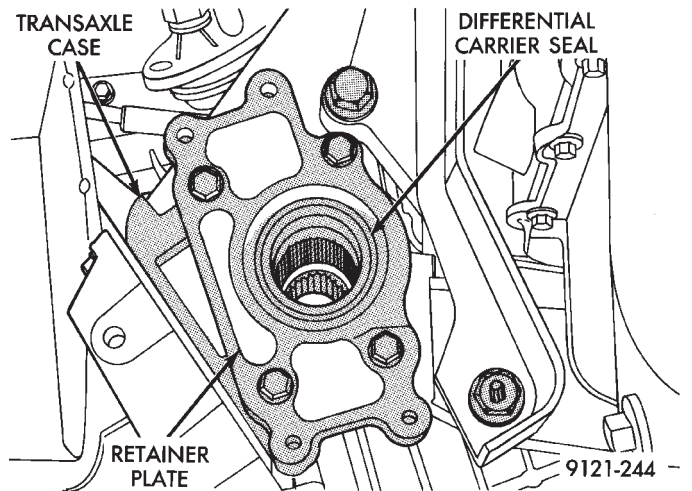

Fig. 7 Transaxle Differential Carrier Seal

INSTALLATION

- (1) Using a large socket, carefully install new seal. The spring side of the seal must face the transaxle differential.
- (2) Reinstall the P.T.U. into the vehicle.
- (3) Check and fill fluids as required.



POWER TRANSFER UNIT REAR COVER O-RING

REMOVAL

- (1) Raise vehicle on hoist.
- (2) Remove rear cover retaining bolts (Fig. 1).

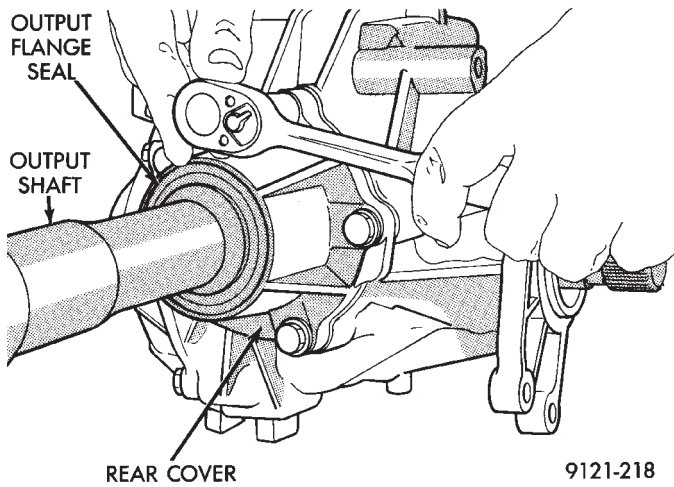

Fig. 1 Rear Cover Bolts

- (3) Index rear cover to the case for later reassembly (Fig. 2).

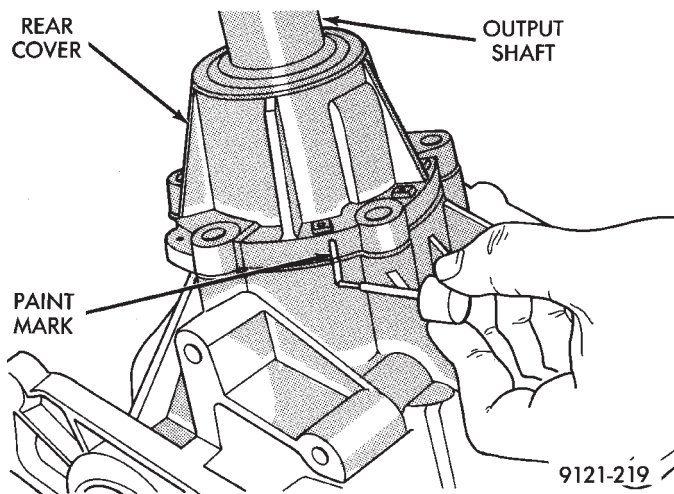

Fig. 2 Mark Rear Cover

- (4) Pull rear cover out of the P.T.U. case (Fig. 3).
- (5) Remove rear cover O-Ring (Fig. 4).
- (6) To Install, Reverse Removal Procedure.

POWER TRANSFER UNIT OUTPUT SEAL

The power transfer unit must be removed from the vehicle to replace this seal.

REMOVAL

- (1) Raise vehicle on hoist.
- (2) Remove propeller shaft.
- (3) Remove rear cover retaining bolts (Fig. 5).
- (4) Index rear cover to the case for later reassembly (Fig. 6).
- (5) Pull rear cover out of the P.T.U. case (Fig. 7).

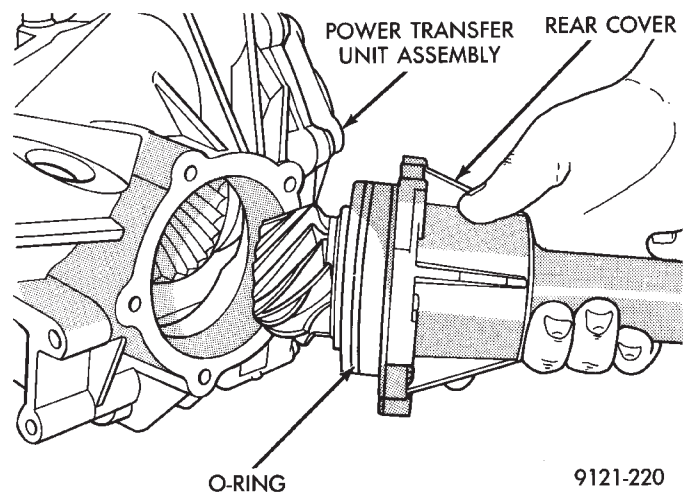

Fig. 3 Rear Cover Removal

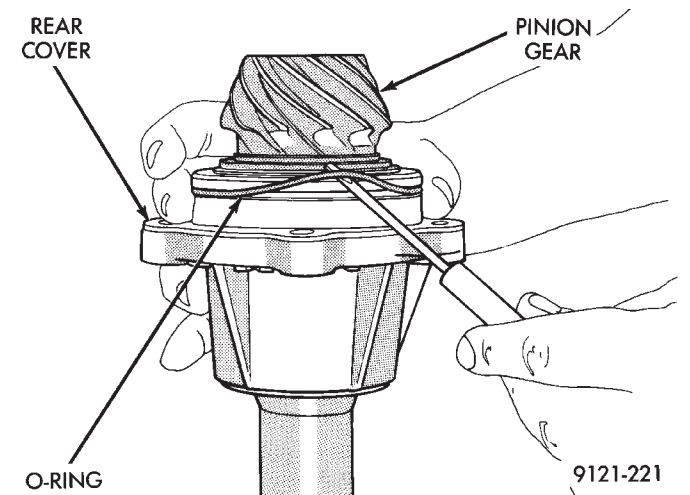

Fig. 4 O-Ring Removal

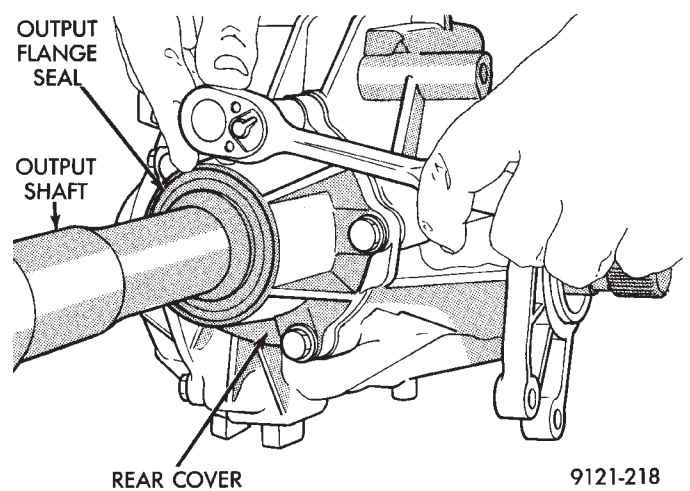

Fig. 5 Rear Cover Bolts

- (6) Remove output flange nut (Fig. 8).
- (7) Index the pinion to the flange (Fig. 9).
- (8) Using a hydraulic press, press off output flange from pinion.

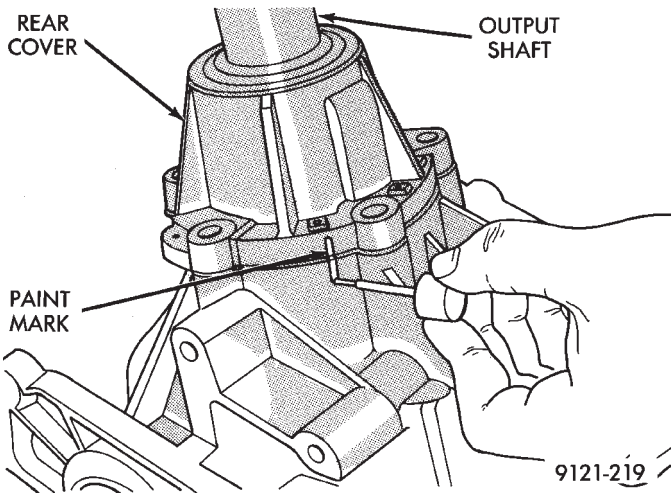

Fig. 6 Mark Rear Cover

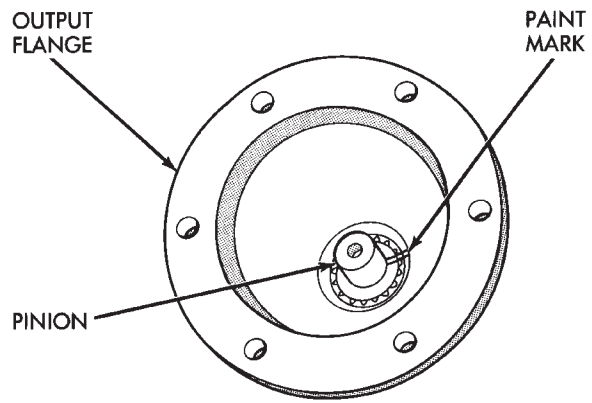

Fig. 9 Mark Flange and shaft

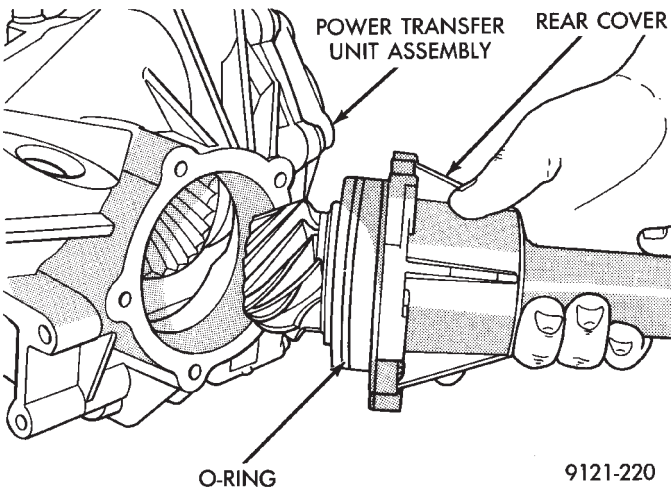

Fig. 7 Rear Cover Removal

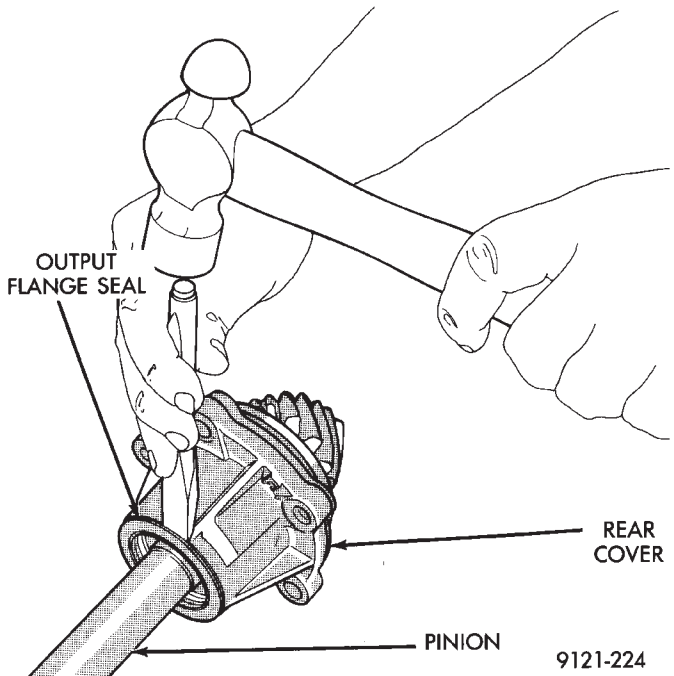

Fig. 10 Seal Removal

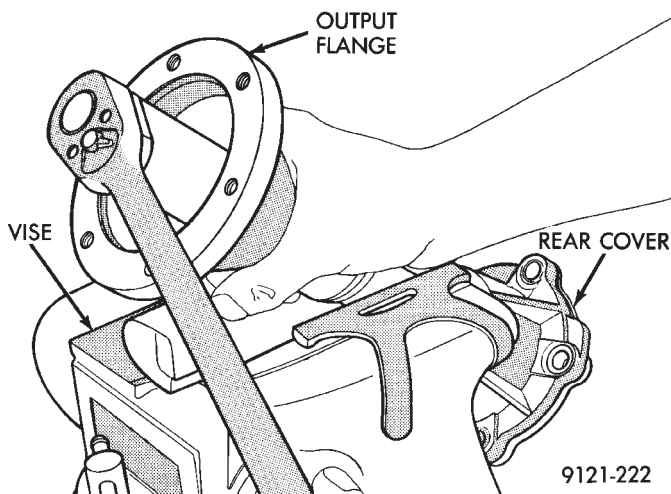

Fig. 8 Output Flange Nut

(9) Use a hammer and chisel to remove output seal (Fig. 10).

CAUTION: If the output flange requires replacement, a new shim may be required. Refer to Output Flange

Shim Selection procedure in this section to determine correct shim requirements.

INSTALLATION

- (1) Install new seal with Seal Installer 5049 (Fig. 11).
- (2) If the original flange is used, align index marks and press flange onto pinion. If a new flange is used disregard the alignment marks on the pinion and press flange onto the pinion.
- (3) Install flange nut and tighten to 163 N•m (120 ft. lbs.).
- (4) Install rear cover. Use care not to cut rear cover O-Ring when installing rear cover into P.T.U. housing.

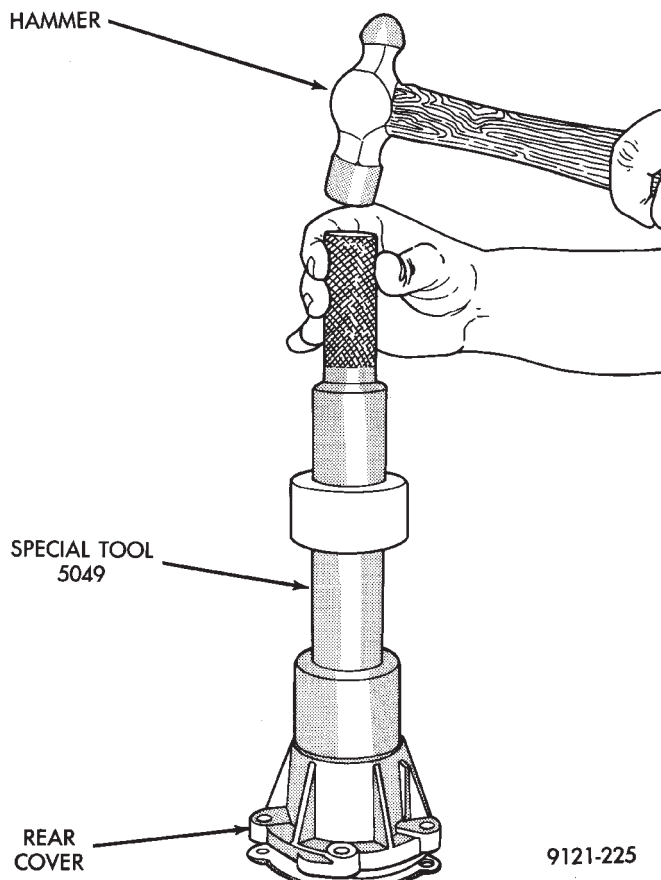

Fig. 11 Seal Installation

- (5) Install rear cover retaining bolts and tighten to 28 N•m (250 in. lbs.).
- (6) Install propeller shaft.
- (7) Check and fill fluids as required.

OUTPUT FLANGE SHIM SELECTION

This procedure is used when the output flange is replaced. Replacement of the output flange requires installation of the correct size shim to maintain bearing preload. **The shim must protrude from the new output flange the same distance that the original shim protruded from the original flange.**

- (1) Stand the original output flange on end with shim side pointing up.
- (2) Place original shim into groove in top of flange.
- (3) Place a straight edge across the shim.
- (4) Using feeler gauge, measure the distance between the straight edge and the top of the flange (Fig. 12). Record this measurement.
- (5) Repeat steps 1 through 4 using the **new flange and the original shim**. Record this measurement.
- (6) If measurements are not equal, use a new shim that will protrude from new output flange the same amount that original shim protruded from original output flange.

For Example: The original shim protrudes 0.075 inch from the original output flange. Place the **original shim** into the new output flange. The protrusion of the

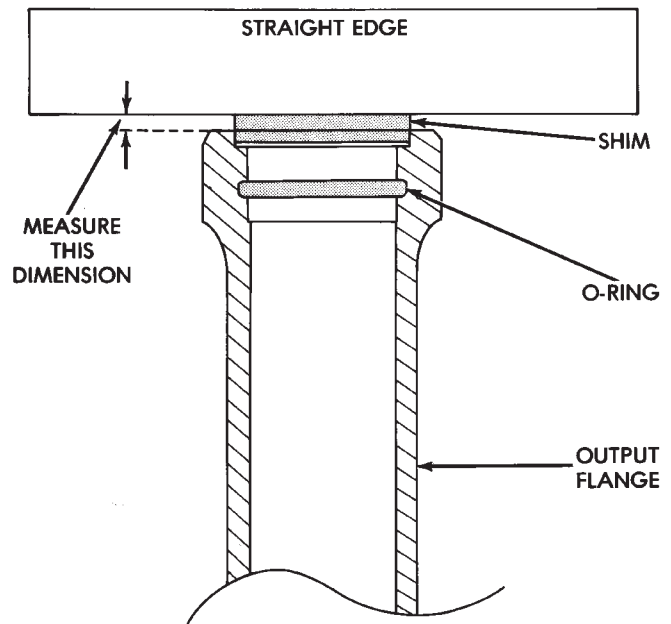

9121-279

Fig. 12 Output Flange Shim Measurement

shim in the new flange is 0.085 inch. This indicates that a 0.010 inch thinner shim is required to maintain the original protrusion.

- (7) Install output flange and torque flange nut to 163 N•m (120 ft. lbs.).

- (8) Check the turning torque of the pinion before installing the rear cover into the P.T.U. The turning torque should be between 2.6 N•m and 3.0 N•m (23 in. lbs. and 27 in. lbs.).

POWER TRANSFER UNIT INPUT SHAFT COVER SEAL

The power transfer unit input shaft cover seal is the larger of the two seals located on the inside of the end cover. The differential bearing cup must be removed to service this seal.

The Power Transfer Unit must be removed from vehicle to perform this operation.

REMOVAL

- (1) Remove P.T.U. end cover bolts (Fig. 1).
- (2) Gently tap on end cover ears to separate cover from case (Fig. 2).
- (3) Use special tool No. 6514 and remove the differential bearing race located in the end cover (Fig. 3). The race must be removed to gain access to the seal.
- (4) Use special tool No. 7794-A to remove seal (Fig. 4).

INSTALLATION

- (1) Clean and inspect seal area.

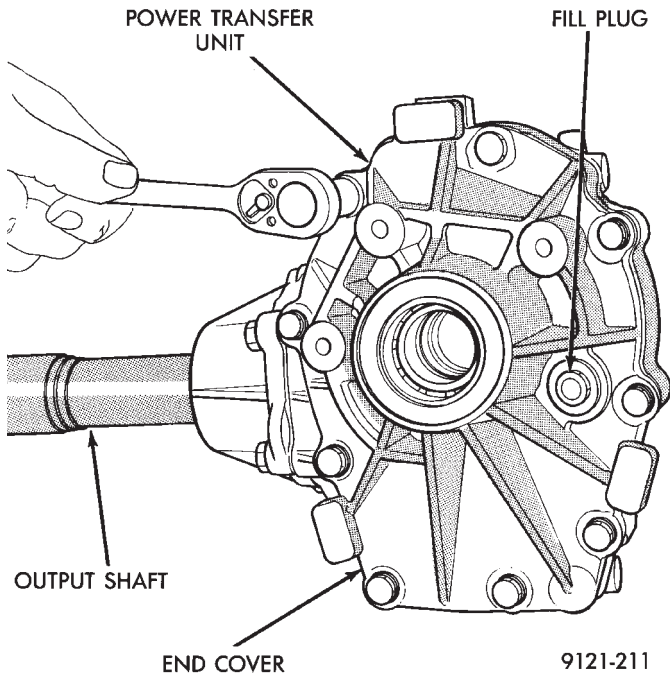

Fig. 1 P.T.U. End Cover Bolts

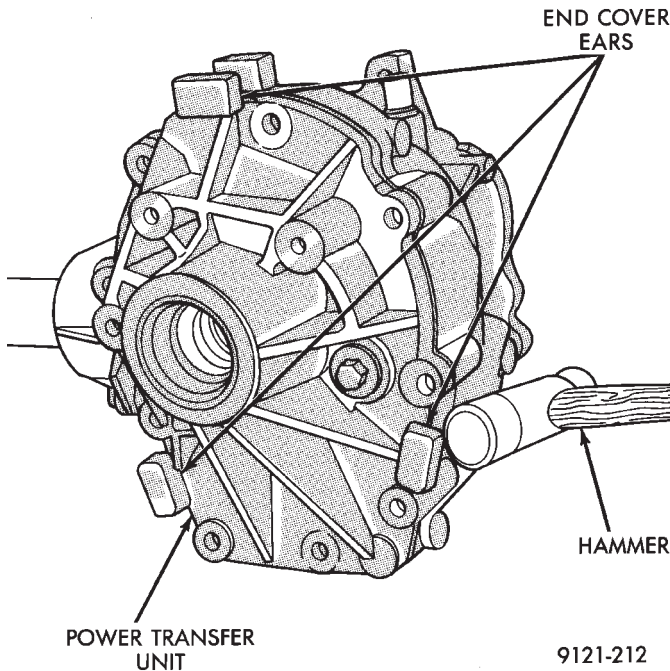

Fig. 2 End Cover Removal

(2) Use special tool No. MD998803 and install seal (Fig 5). When installing seal the spring side of the seal must face toward the special tool.

(3) Reinstall the original bearing race and shim using special tool No. 6522 (Fig. 6 and 7).

CAUTION:The original shim must be installed behind the bearing cup to maintain proper bearing preload.

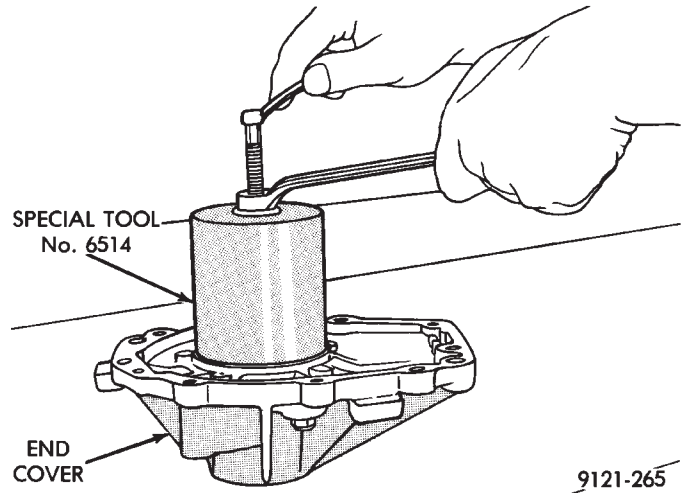

Fig. 3 Bearing Race Removal

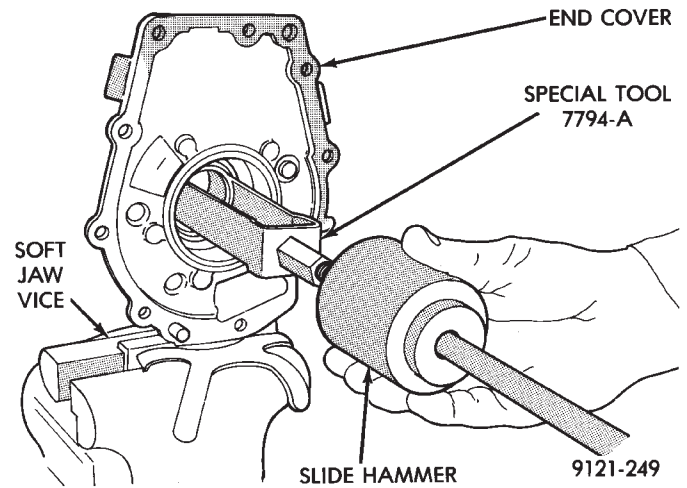

Fig. 4 Seal Removal

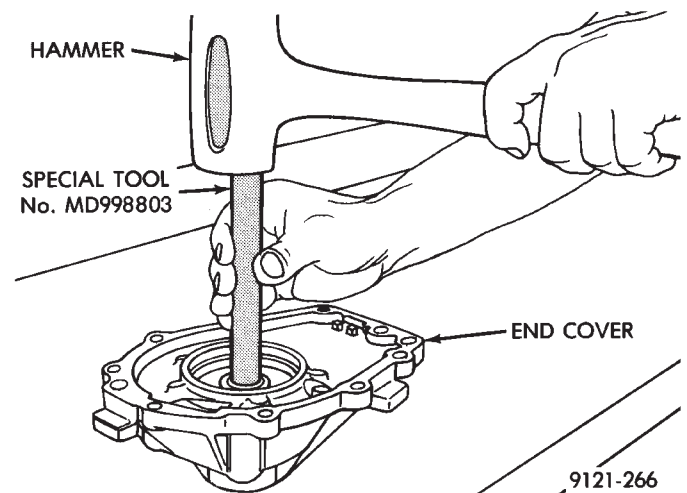

Fig. 5 Seal Installation

(4) Apply Mopar® Gasket Maker, Loctite Gasket Eliminator No. 518 or equivalent to sealing surfaces of end cover.

(5) Place end cover onto P.T.U. case and install bolts. Tighten bolts to 28 N•m (250 in. lbs.) in the se-

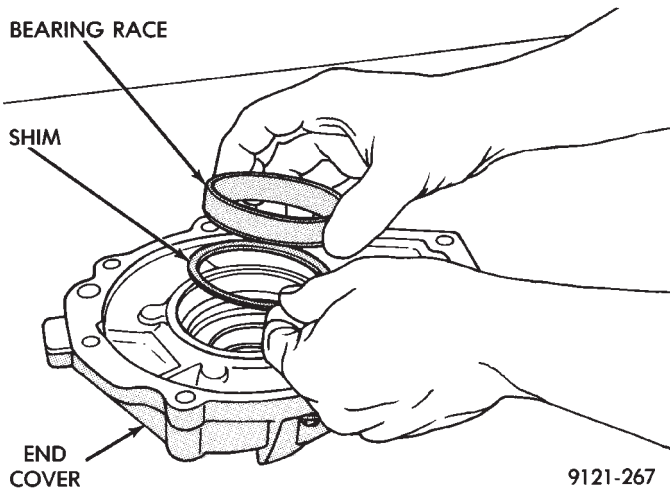

Fig. 6 Bearing Shim and Race

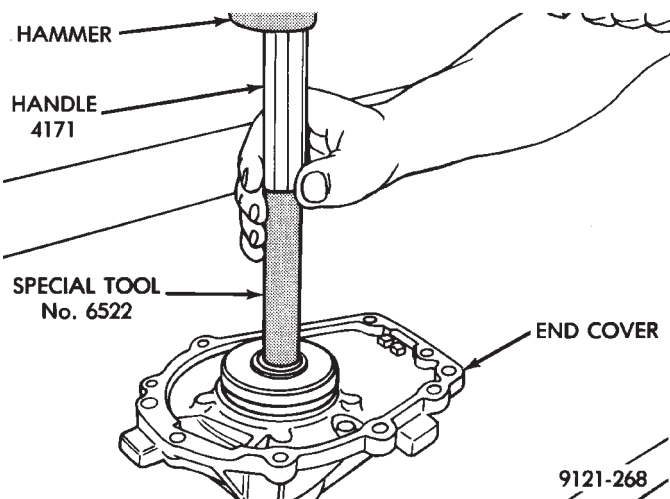

Fig. 7 Installing Bearing Race

quence shown in figure 8. Retighten first bolt after all others are tight.

CAUTION: When end cover is installed be careful not to damage the P.T.U. Input Shaft Cover Seal.

- (6) Reinstall P.T.U. assembly into vehicle.
- (7) Check and fill fluids as required.

POWER TRANSFER UNIT HALF SHAFT INNER SEAL

The power transfer unit half shaft inner seal is the smaller of the two seals located on the inside of the end cover.

REMOVAL

- (1) Remove power transfer unit from the vehicle.
- (2) Remove end cover bolts (Fig. 1).
- (3) Tap on end cover ears to separate cover from case (Fig. 2).
- (4) Drive seal out with a hammer and small chisel (Fig. 3).

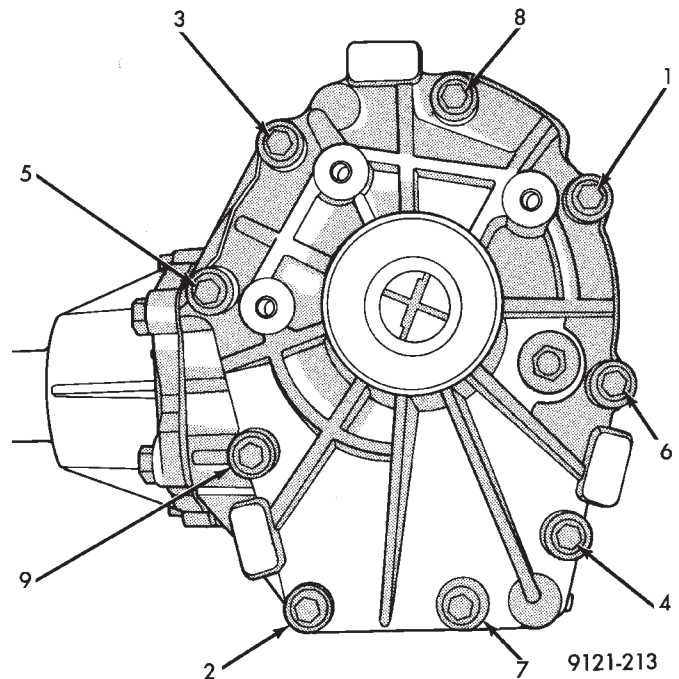

Fig. 8 Bolt Tightening Sequence

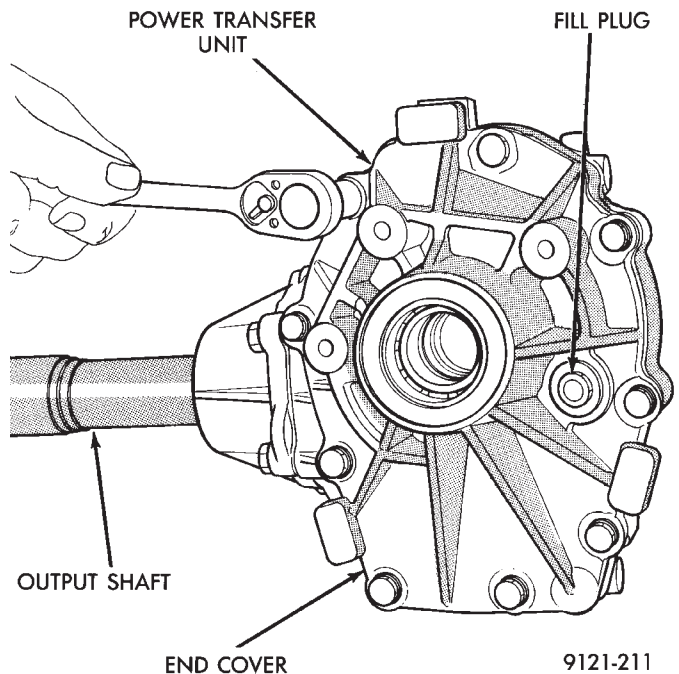

Fig. 1 End Cover Bolts

INSTALLATION

- (1) Clean and inspect seal area.
- (2) Install seal with a 1 1/16 inch socket (Fig. 4). The seal must be installed with the spring side of the seal facing end cover ball bearing. The seal will bottom against a machined shoulder in the cover.
- (3) Clean sealing surfaces of the end cover and P.T.U. case. Apply a bead of Mopar® Gasket Maker, Loctite Gasket Eliminator No. 518 or equivalent.

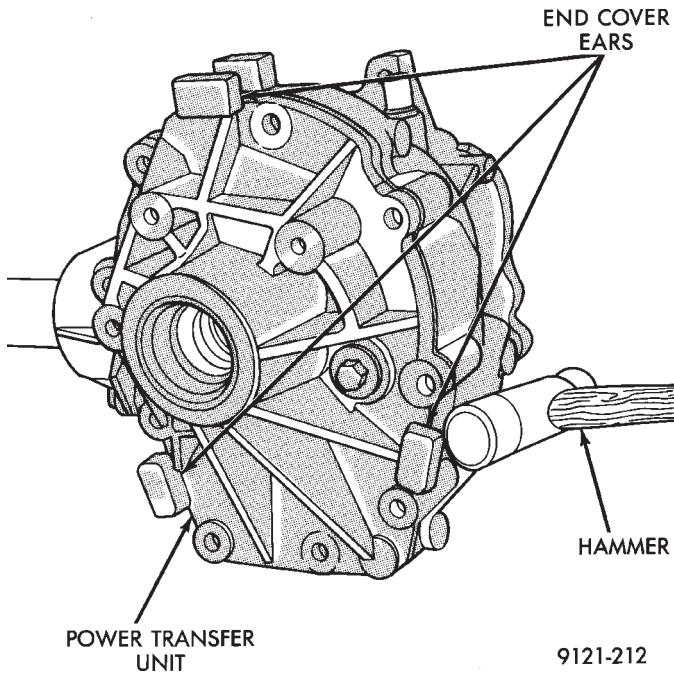

Fig. 2 End Cover Removal

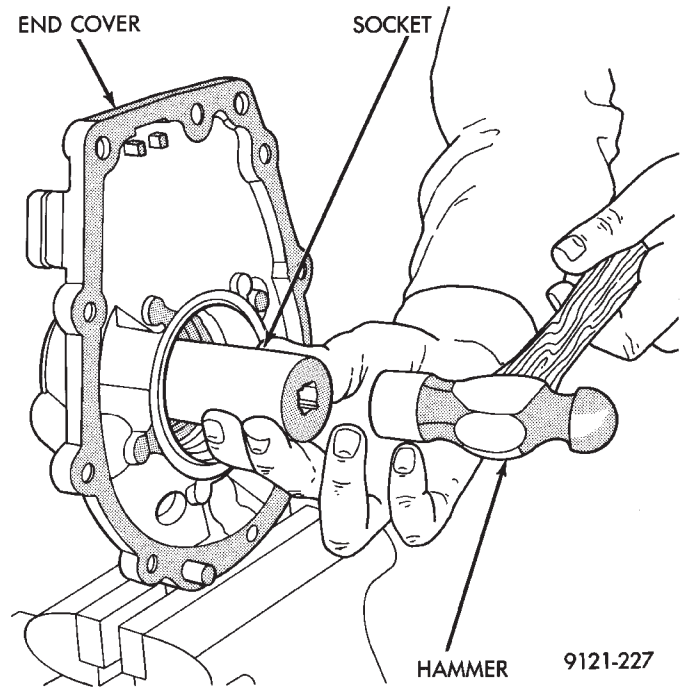

Fig. 4 Seal Installation

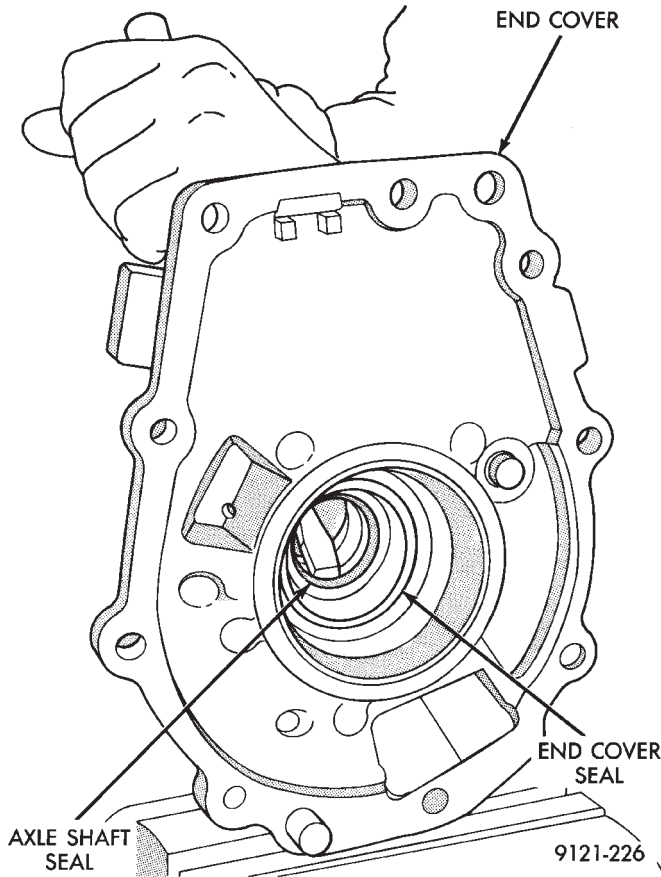

Fig. 3 Seal Removal

(4) Place end cover onto P.T.U. case and install bolts. Tighten bolts to 28 N•m (250 in. lbs.) in the sequence shown in figure 5. Retighten first bolt after all other bolts are tight.

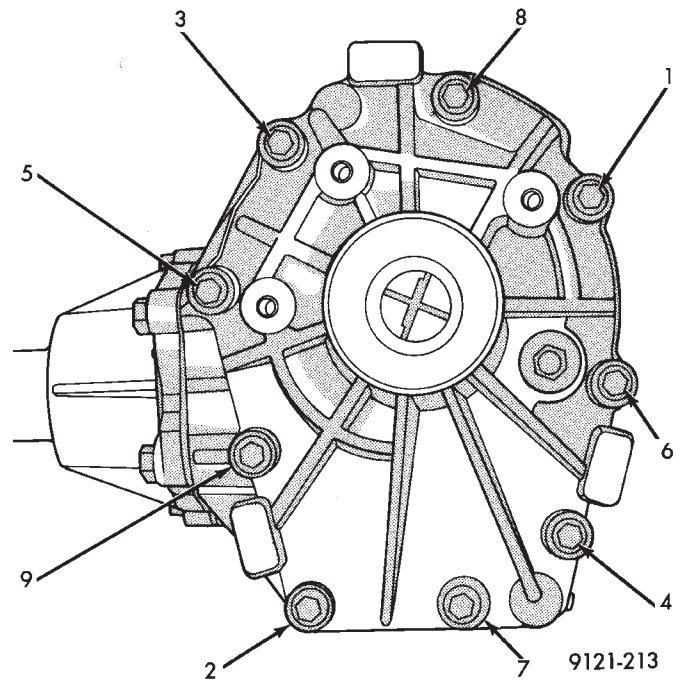

Fig. 5 Bolt Tightening Sequence

- (5) Reinstall P.T.U. assembly.
- (6) Check and fill fluids as required.

POWER TRANSFER UNIT INPUT SHAFT END SEAL
The input shaft end seal is located on the end of the input shaft.

REMOVAL

- (1) Remove power transfer unit from the vehicle.
- (2) Remove end cover bolts (Fig. 6).

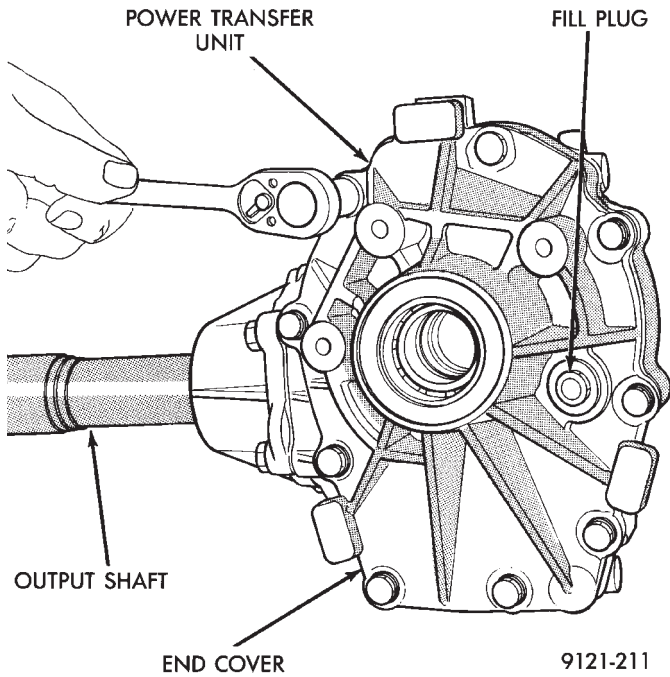

Fig. 6 End Cover Bolts

(3) Tap on end cover ears to separate end cover from case (Fig. 7).

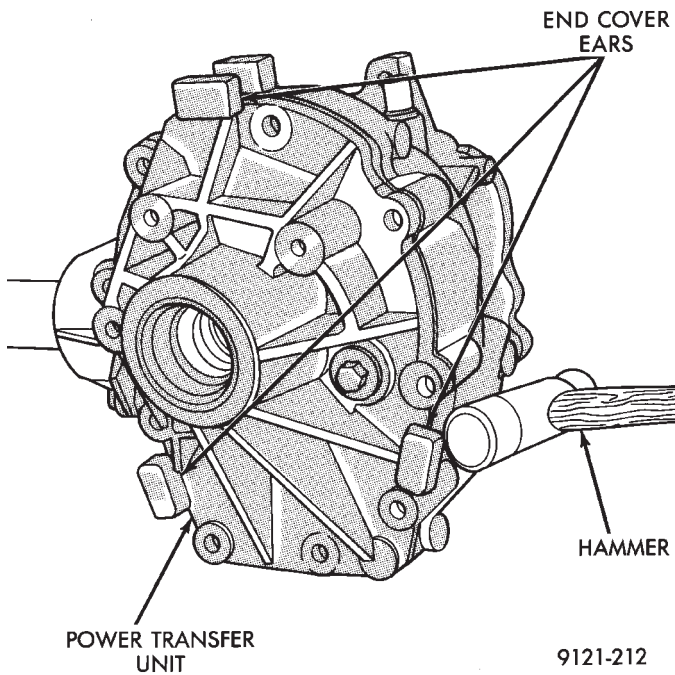

Fig. 7 End Cover Removal

(4) Pry out seal with a pry bar (Fig. 8).

INSTALLATION

- (1) Clean and inspect seal area.
- (2) Remove input shaft from housing and stand on soft block of wood. Install input shaft end seal with seal installer 5065 and handle C-4171.

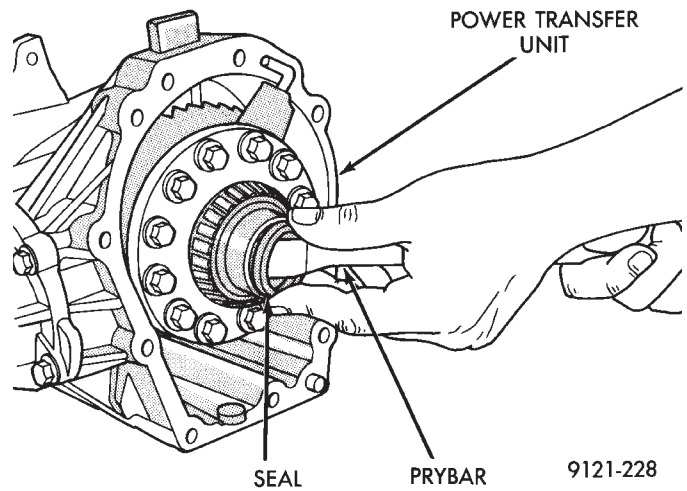

Fig. 8 Seal Removal

(3) Lubricate seal lip after installing seal into input shaft.

(4) Clean sealing surfaces of the end cover and P.T.U. case. Apply a bead of Mopar® Gasket Maker, Loctite Gasket Eliminator No. 518 or equivalent.

(5) Place end cover onto P.T.U. case and install bolts. Tighten bolts to 28 N•m (250 in. lbs.) in the sequence shown in figure 9. Retighten first bolt after all others are tight.

CAUTION: When end cover is installed be careful not to damage the P.T.U. Input Shaft Cover Seal.

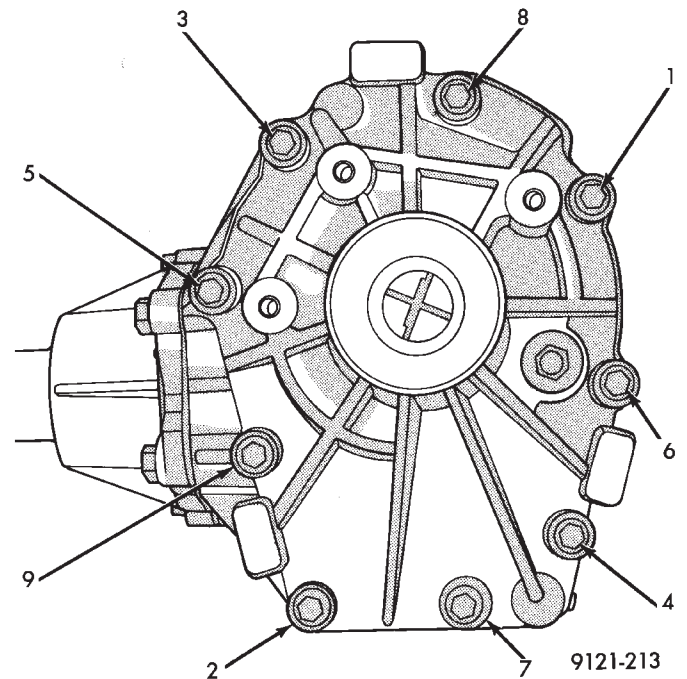

Fig. 9 Bolt Tightening Sequence

- (6) Reinstall P.T.U. assembly.
- (7) Check and fill fluids as required.

POWER TRANSFER UNIT OUTER HALF SHAFT SEAL

The outer half shaft seal is located on the outside of the end cover. The P.T.U. does not have to be removed to replace this seal.

REMOVAL

- (1) Lift vehicle on hoist.
- (2) Remove right front half shaft from vehicle.
- (3) Remove seal with a chisel and hammer (Fig. 1).

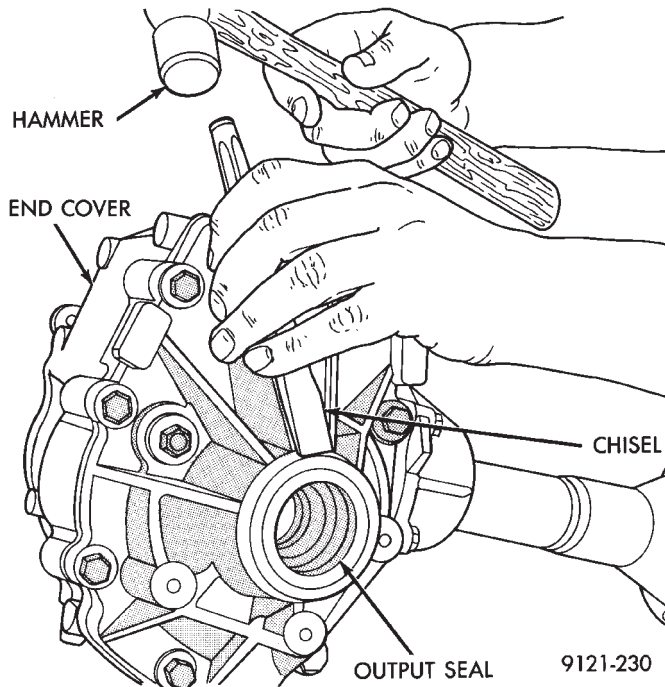

Fig. 1 Seal Removal

INSTALLATION

- (1) Clean and inspect seal area.
- (2) Install new seal with seal installer MD998334 (Fig. 2).

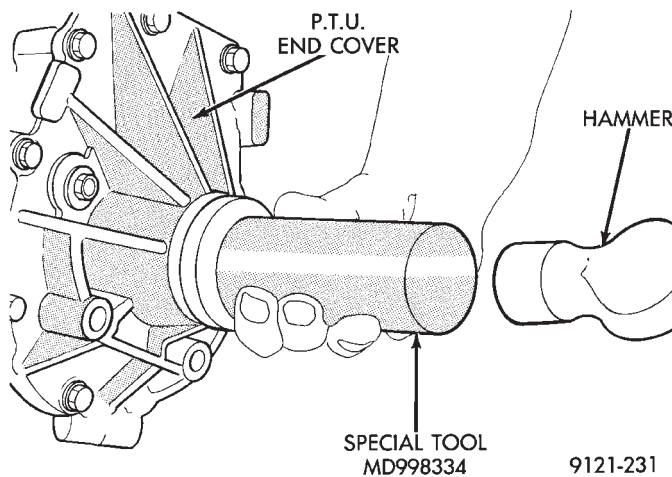

Fig. 2 Seal Installation

- (3) Reinstall right front half shaft.
- (4) Check and fill fluids as required.

POWER TRANSFER UNIT END COVER BALL BEARING

The end cover ball bearing can be removed and installed without removing the Power Transfer Unit from the vehicle. When replacing the bearing the output seal must be removed to gain access to the bearing.

REMOVAL

- (1) Raise vehicle on hoist.
- (2) Remove right front half shaft from vehicle.
- (3) Remove output seal with a hammer and chisel (Fig. 3).

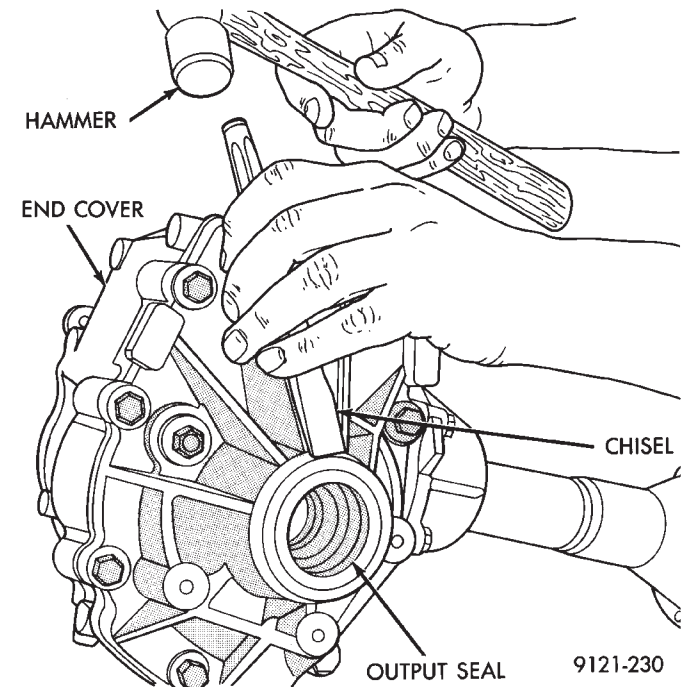

Fig. 3 Output Seal Removal

- (4) Remove bearing retaining snap ring (Fig. 4).

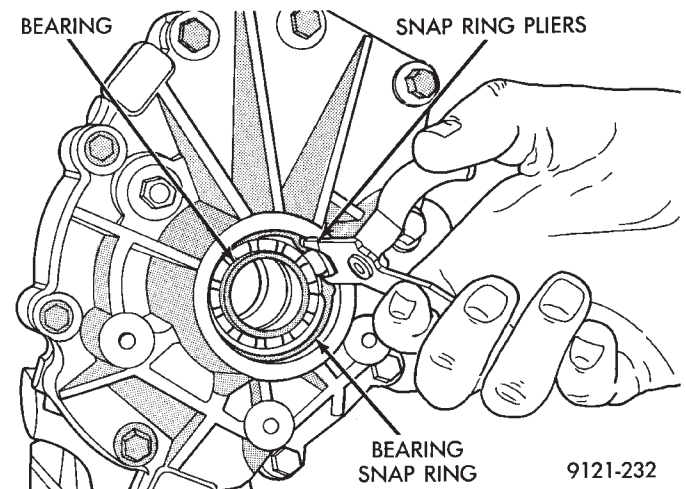

Fig. 4 Bearing Snap Ring

(5) Use bearing puller MD998346 to remove bearing (Fig.5).

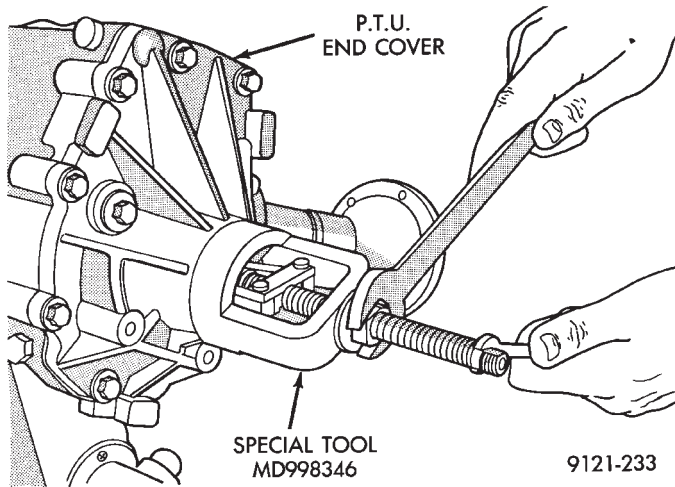

Fig. 5 Bearing Removal

INSTALLATION

(1) Use bearing driver L-4530 and handle C-4171-2 to install bearing.

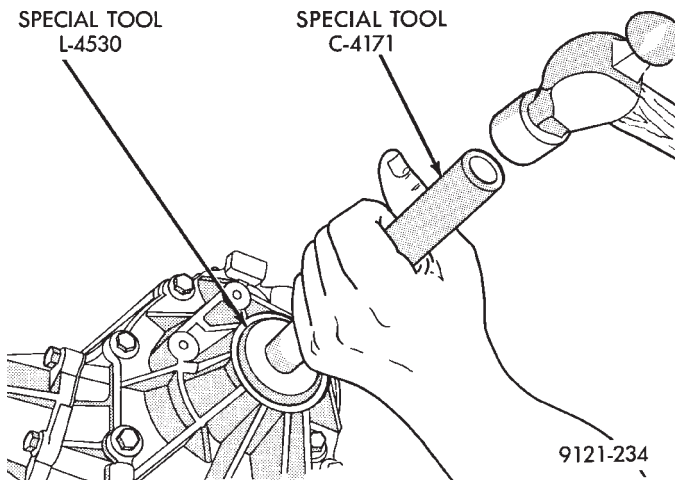

Fig. 6 Bearing Installation

(2) Install bearing retaining snap ring.

CAUTION:When installing bearing retaining snap ring, be sure to index the snap ring so that the snap ring does not cover bearing oil passage.

(3) Install new output seal using MD998334 seal installer (Fig. 7). **Do not reuse the old seal.**

(4) Reinstall right front half shaft.

(5) Check and fill fluids as required.

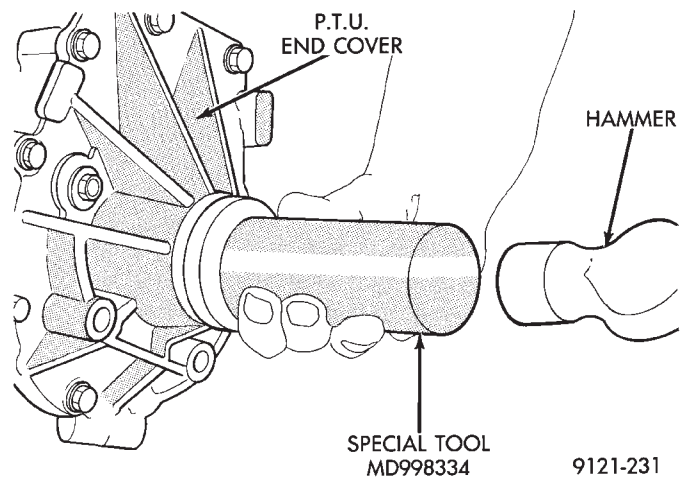

Fig. 7 Installing New Seal

4-SPEED ELECTRONIC TRANSAXLE ON-BOARD DIAGNOSTICS

INDEX

	page		page
Ccd Bus	157	Limp-In Mode	157
DRBII (Diagnostic Read-Out Box)	158	On-Board Diagnostics Information	157
Fault Code Charts	158	System Fault Messages/Codes	157
General Information	157	Wiring Diagram	174
Glossary	175		

GENERAL INFORMATION

The information in this manual is designed to help the technician understand and repair the electronic transaxle with the aid of the built in on-board diagnostics.

Chrysler Corporation has developed a complete set of diagnostic manuals which cover diagnosis. They have been designed to make transaxle diagnosis accurate and simple. Use these manuals with the DRBII and the latest cartridge, when diagnosing transaxle problems.

ON-BOARD DIAGNOSTICS INFORMATION

The 4-Speed Electronic Transaxle is controlled and monitored by the EATX controller. The controller monitors critical input and output circuits within the Electronic Transaxle system.

Some circuits are tested continuously; others are checked only under certain conditions. Each circuit monitored by the controller has a corresponding fault message assigned to it that can be read with the DRBII.

If the on-board diagnostic system senses that one of the circuits is malfunctioning, the corresponding fault message is stored in memory. If the malfunction goes away after the fault code is stored, the controller will erase the fault after 75 key cycles.

CCD BUS

In order to diagnose the EATX, fault codes in the EATX controller's memory should be read using the Diagnostic Readout Box (DRBII). If more than one fault code exists, diagnostic priority should be given to the most recent code. With CCD bus bias and communication problems, however, the DRBII displays an appropriate message and fault codes might not be accessible until the bus problem is fixed. The following is a list of probable causes for a bus problem:

- Open or short to ground/battery in either or both CCD bus wires (pins 4 and 43).
- Open or short to ground/battery in either or both EATX bias wires (pin 5 and 44) on vehicles requiring EATX to bias the bus.
- Open or short to ground/battery in the diagnostic connector bus wire.

- Internal failure of any controller connected to the bus.

The CCD bus should have 2.5 volts (+2.5 volts on CCD+ and -2.5 volts on CCD-).

The bus error message displayed by the DRBII should be helpful in diagnosing the CCD bus.

For more detailed information on diagnosing CCD bus problems, refer to the 1992 diagnostic procedures Manual for non-communication with the CCD bus problems. All other problems refer to the 1992 Body Vehicle Communications Diagnostic Procedures Manual.

SYSTEM FAULT MESSAGES/CODES

Fault codes are two-digit numbers that identify which circuit is malfunctioning. A fault code can be set for hydraulic and mechanical reasons as well as for electrical problems. In most cases, fault codes do not pinpoint which specific component is defective.

Fault code can only be read with the use of the DRBII Read-out Box or equivalent.

HARD FAULTS

Any fault code that comes back within 3 engine starts (reset count 3 or less) is a "Hard Fault". This means that the defect is there every time the controller checks that circuit.

SOFT FAULTS

A "Soft Fault" is one that occurs intermittently. It is not there every time the controller checks the circuit. Most soft faults are caused by wiring or connector problems. Intermittent defects must be looked for under the specific conditions that caused them.

LIMP-IN MODE

The controller continuously checks for electrical and internal transaxle problems. When a problem is sensed, the controller stores a fault code. All but twelve of these codes cause the transaxle to go into the "Limp-in mode". While in this mode, electrical power is taken away from the transaxle. When this happens, the only transaxle ranges that will function are:

- Park
- Neutral
- Reverse
- Second Gear

No upshifts or downshifts are allowed while in the Limp-in mode. The position of the manual valve alone allows the three ranges that are available.

Although engine performance will be reduced while in this mode, the vehicle can be driven in for service.

DRBII (DIAGNOSTIC READ-OUT BOX)

The DRBII is a diagnostic read-out box designed by Chrysler to gain access to the on-board diagnostics that are found on all Chrysler-built cars and trucks.

The DRBII has a few diagnostic capabilities by itself. To perform most diagnostic tests, a program cartridge must be inserted. It contains the diagnostic test programs.

There are diagnostic read-out boxes available from other manufactures that can be used on Chrysler vehicles. However, the diagnostic test procedures in this manual have been designed for use with the Chrysler's DRBII diagnostic readout box.

The DRBII operates by communicating with the controller of the vehicle system being tested. To communicate with the controller, the DRBII must be connected to the blue CCD bus connector located under the instrument panel. Refer to the "Using the DRBII" manual or the Diagnostic Procedures Manual for complete information on how to hook up and use the DRBII.

FAULT CODE CHARTS

Below is a brief description of what each section of the fault code charts are addressing.

- **FAULT CODE**-Tells the code number and name (as shown on the DRBII).
- **BACKGROUND**-A brief description of the circuit that the controller is monitoring.
- **WHEN CHECKED**-The point of time or condition when the controller makes it's system check.
- **ARMING CONDITIONS**-The parameters that must be met before a code can be set.
- **FAULT CONDITION**-What the controller saw that is determined to be a problem. (ie. voltage to high or low, switch/solenoid problems)
- **FAULT SET TIME**-Refers to the amount of time (in seconds) a failure must occur before a fault code is set in memory.
- **EFFECT**-Refers to how the fault effects transaxle operations.
- **POSSIBLE CAUSE**-Refers to the systems or circuits which could cause the fault to be recorded.

FAULT CODE 11

FAULT CODE:	11 Internal A-604 Controller (Watchdog Circuit Test)
BACKGROUND:	The internal watchdog (WD) circuit continuously monitors the microprocessor. It provides a transmission limp-in when it detects a problem in the microprocessor. On the other hand, the microprocessor periodically TESTs the WD's ability to provide this shutdown function.
WHEN CHECKED:	After a reset (ignition key turned to the RUN position or after cranking engine), and periodically thereafter.
ARMING CONDITIONS:	(1) Solenoid test must not be in progress. (2) Watchdog test must be in progress. (3) A specific type of watchdog test must be scheduled.
FAULT CONDITIONS:	The Delay/Monitor line remains high after period has elapsed for corresponding Watchdog Test.
FAULT SET TIME:	Less than 1 second.
EFFECT:	Transmission limp-in.
POSSIBLE CAUSES:	Internal controller failure.



FAULT CODE 12

FAULT CODE:	12 Battery Was Disconnected. Note: This is not a fault code. It exists to provide reference information only.
BACKGROUND:	A battery-backed RAM is used to maintain some learned values. When the battery is disconnected, this memory is lost and, when the battery is connected, it will be detected by the controller. The code will be set and the learned values will be initialized to known constants.
WHEN CHECKED:	After a reset (ignition key turned to the RUN position or after cranking engine).
ARMING CONDITIONS:	None.
FAULT CONDITIONS:	Battery disconnected or first installation. – OR – Software interrupt. – OR – Watchdog re-initialization.
RESET CONDITIONS:	75 or more restarts without setting a new fault.
FAULT SET TIME:	Less than 1 second.
EFFECT:	Setting the code has no effect except for re-initialization of some learned values. However, disconnecting the battery will result in transmission limp-in.
POSSIBLE CAUSES:	Battery disconnected.

FAULT CODE 13

9221-101

FAULT CODE:	13 Internal A-604 Controller (Watchdog Circuit Shutdown)
BACKGROUND:	The internal watchdog (WD) circuit continuously monitors the microprocessor. It provides a shutdown function when it detects a problem in the microprocessor.
WHEN CHECKED:	After a reset (ignition key turned to the RUN position or after ranking engine), and periodically thereafter.
ARMING CONDITIONS:	(1) Watchdog test must not be in progress. (2) The Delay/Monitor line must be detected to be low. – OR – The relay coil power must be detected to be low. – OR – The switched battery must be detected to be low.
FAULT CONDITIONS:	Delay/Monitor is low for more than 0.6 second. – OR – Delay/Monitor is low and either Relay Power or Switched Battery is low for more than 0.2 second.
FAULT SET TIME:	Less than 1 second.
EFFECT:	Transmission limp-in.
POSSIBLE CAUSES:	Internal controller failure.

FAULT CODE 14

FAULT CODE:	14 EATX Relay Output Always On (Relay Contacts Are Welded Closed)
BACKGROUND:	<p>The EATX relay is used to supply power to the solenoid pack (when in normal operating mode) and to turn off power (when in transmission "limp-in" mode). The relay output (which supplies power to the solenoid pack) is fed back to the controller through pins 16 and 17. It is referred to as SWITCHED BATTERY.</p> <p>After a controller reset (ignition key turned to the RUN position or after cranking engine), the controller energizes the relay. But before this is done, the controller verifies that the relay contacts are open by checking for no voltage on Switched Battery (i.e., relay output).</p>
WHEN CHECKED:	After a reset (ignition key turned to the RUN position or after cranking engine) and after a powerdown.
ARMING CONDITIONS:	Before the controller energizes the solenoid relay.
FAULT CONDITIONS:	Relay output (Switched Battery) has more than 3 volts when relay is not energized by controller.
FAULT SET TIME:	Less than 1 second.
EFFECT:	Transmission limp-in.
POSSIBLE CAUSES:	<p>Relay failure (welded contacts).</p> <p>Short to battery in EATX Relay Coil Power circuit.</p> <p>Short to battery in EATX Relay Output circuit.</p> <p>40-way connector problem (Cavities 15, 16, and 17).</p> <p>Internal controller failure.</p>

9221-103

FAULT CODE 15

FAULT CODE:	15 EATX Relay Output Always Off (Relay Contacts Are Stuck Open)
BACKGROUND:	<p>The EATX relay is used to supply power to the solenoid pack (when in normal operating mode) and to turn off power (when in transmission "limp-in" mode). The relay output (which supplies power to the solenoid pack) is fed back to the controller through pins 16 and 17. It is referred to as SWITCHED BATTERY.</p> <p>After a controller reset (ignition key turned to the RUN position or when cranking engine), the controller energizes the relay. Then the controller makes sure that the relay contacts closed by checking for voltage on Switched Battery (i.e., relay output).</p>
WHEN CHECKED:	After a reset (ignition key turned to the RUN position or after cranking engine).
ARMING CONDITIONS:	After the controller energizes the solenoid relay.
FAULT CONDITIONS:	Relay output (Switched Battery) has less than 3 volts when relay is energized by the controller.
FAULT SET TIME:	Less than 1 second.
EFFECT:	Transmission limp-in.
POSSIBLE CAUSES:	<p>Relay failure (open contacts).</p> <p>Short to ground in EATX Relay Coil Power circuit.</p> <p>Open EATX Relay Coil Power circuit between relay and controller.</p> <p>Open EATX Relay Output circuit between relay and controller.</p> <p>Open EATX Power Ground (B-) circuit from relay to ground.</p> <p>Open Battery Feed circuit from relay to splice.</p> <p>40-way connector problem (cavities 15, 16, and 17).</p> <p>Internal controller failure.</p>

9221-104

FAULT CODE 16

FAULT CODE:	16 Internal A-604 Controller (ROM Check Failure)
BACKGROUND:	When the controller is reset, the microprocessor checks the integrity of the program memory (ROM). It adds all used bytes in the program memory. The amount should be the same as a known constant (stored in program memory).
WHEN CHECKED:	After a reset (ignition key turned to the RUN position or after cranking engine).
ARMING CONDITIONS:	None.
FAULT CONDITIONS:	ROM check sum does not match a known constant.
FAULT SET TIME:	Less than 1 second.
EFFECT:	Transmission limp-in.
POSSIBLE CAUSES:	Internal controller failure.

9221-105

FAULT CODE 17

FAULT CODE:	17 Internal A-604 Controller (RAM Check Failure)
BACKGROUND:	When the controller is reset, the microprocessor checks the integrity of each RAM location by writing to it and reading back from it. The read value should be the same as the value written.
WHEN CHECKED:	After a reset (ignition key turned to the RUN position or after cranking engine).
ARMING CONDITIONS:	Data read from at least one RAM location does not match data written to it.
FAULT CONDITIONS:	RAM check sum does not match a known constant.
FAULT SET TIME:	Less than 1 second.
EFFECT:	Transmission limp-in.
POSSIBLE CAUSES:	Internal controller failure.

9221-106

FAULT CODE 18

FAULT CODE:	18 Engine Speed Sensor Circuit (Loss of Engine Speed Signal)
BACKGROUND:	EATX uses a distributor signal to calculate the engine rpm (which could be zero when the ignition key is in the RUN position and the engine is not running). When the calculated engine rpm is almost zero, it is compared to the engine speed received from the engine controller over the CCD bus to confirm that the engine is actually not running. Otherwise this means a problem with the engine speed signal circuit.
WHEN CHECKED:	Every 0.007 second.
ARMING CONDITIONS:	(1) Calculated engine speed is less than or equal to the start-run threshold of 390 rpm. (2) CCD bus must be operational during the last 1.0 second.
FAULT CONDITIONS:	Engine speed received from the engine controller over the CCD bus is greater than 384 rpm.
FAULT SET TIME:	2 seconds.
EFFECT:	Transmission limp-in.
POSSIBLE CAUSES:	Open/short in Engine Speed Signal circuit (distributor pickup or crank sensor signal). Defective distributor reference pickup or crank sensor. 40-way connector problem (cavity 45). Internal controller failure.

9221-107

FAULT CODE 19

FAULT CODE:	19 Bus Communication With Engine Module
BACKGROUND:	EATX communicates with the engine controller over the CCD bus. Engine rpm, Engine and Ambient Temperature are among the information received by EATX. The controller continuously monitors the bus activity and receives the messages it needs.
WHEN CHECKED:	Every 0.007 second.
ARMING CONDITIONS:	Engine speed must not equal zero (engine cranking or running).
FAULT CONDITIONS:	No CCD messages received for 10 seconds.
FAULT SET TIME:	10 seconds.
EFFECT:	No limp-in. Due to loss of temperature information: (a) Delayed 3/4 shift and early 4/3 shift for few minutes after engine is started. (b) No lock-up operations for a few minutes after the engine is started.
POSSIBLE CAUSES:	Open Serial Bus (+) circuit or Serial Bus (-) circuits between EATX and engine controller. Shorted Serial Bus (+) or Serial Bus (-) circuit. CCD bus biasing problem (bus has to be properly biased by one of the vehicle's controllers). Engine-controller CCD problem circuit. EATX or body-controller CCD circuit problem.

9221-108



FAULT CODE 20

FAULT CODE:	20 Switched Battery
BACKGROUND:	<p>The EATX relay is used to supply power to the solenoid pack (when in normal operating mode) and to turn off power (when in transmission "limp-in" mode). The relay output (which supplies power to the solenoid pack) is fed back to the controller through pins 16 and 17. It is referred to as SWITCHED BATTERY.</p> <p>After a controller reset (ignition key turned to the RUN position or after cranking engine), the controller energizes the relay. But before this is done, the controller verifies that the relay contacts are open by checking for no voltage on Switched Battery (i.e., relay output). After Switched Battery is verified for no voltage, the voltage of the solenoid pack pressure switches is also checked. Since the solenoid pack is not powered up, there should be no voltage on any of the pressure switches. Otherwise there is a problem on the switched battery.</p>
WHEN CHECKED:	After a reset (ignition key turned to the RUN position or after cranking engine).
ARMING CONDITIONS:	Switched battery relay contacts are open.
FAULT CONDITIONS:	A voltage is detected on any of the pressure switches before the relay is energized.
FAULT SET TIME:	Less than 1 second.
EFFECT:	Transmission limp-in.
POSSIBLE CAUSES:	<p>Defective EATX relay (welded contacts) with an open EATX Relay Output circuit between controller and splice.</p> <p>Intermittent short to battery on EATX Relay Output circuit.</p> <p>Defective relay (intermittent contacts).</p> <p>Internal controller failure.</p>



FAULT CODE 21-27

<p>FAULT CODE:</p>	<p>21-27 Pressure Switch Circuits Code 21 OD Pressure Switch Circuit Code 22 2/4 Pressure Switch Circuit Code 23 2/4-OD Pressure Switch Circuit Code 24 LR Pressure Switch Circuit Code 25 LR-OD Pressure Switch Circuit Code 26 LR-2/4 Pressure Switch Circuit Code 27 All Pressure Switch Circuits</p>																												
<p>BACKGROUND:</p>	<p>The A-604 transmission system uses three pressure switches to monitor the fluid pressure in the LR, 2/4, and OD elements. The pressure switches are continuously checked for the correct states in each gear as indicated below:</p> <p style="text-align: center;">Normal Pressure Switch States</p> <table border="1" data-bbox="740 674 1175 909"> <thead> <tr> <th>GEAR</th> <th>LR</th> <th>2/4</th> <th>OD</th> </tr> </thead> <tbody> <tr> <td>R</td> <td>O</td> <td>O</td> <td>O</td> </tr> <tr> <td>N</td> <td>C</td> <td>O</td> <td>O</td> </tr> <tr> <td>1ST</td> <td>C</td> <td>O</td> <td>O</td> </tr> <tr> <td>2ND</td> <td>O</td> <td>C</td> <td>O</td> </tr> <tr> <td>3RD</td> <td>O</td> <td>O</td> <td>C</td> </tr> <tr> <td>4TH</td> <td>O</td> <td>C</td> <td>C</td> </tr> </tbody> </table> <p style="text-align: center;">O = Switch is open C = Switch is closed</p> <p>When a pressure switch mismatch is detected, the solenoid circuits are tested for continuity. If that test fails, solenoid circuits are blamed for the pressure switches mismatch. Otherwise the appropriate pressure switch code is set.</p>	GEAR	LR	2/4	OD	R	O	O	O	N	C	O	O	1ST	C	O	O	2ND	O	C	O	3RD	O	O	C	4TH	O	C	C
GEAR	LR	2/4	OD																										
R	O	O	O																										
N	C	O	O																										
1ST	C	O	O																										
2ND	O	C	O																										
3RD	O	O	C																										
4TH	O	C	C																										
<p>WHEN CHECKED:</p>	<p>Every 0.007 second.</p>																												
<p>ARMING CONDITIONS:</p>	<p>(1) More than 2.0 seconds since start-up. (2) No loss of transaxle oil pump prime. (3) Engine speed greater than 500 rpm. (4) No shift in progress. (5) Pressure switch mask inconsistent with the normal pressure switch state table. Use DRB II A-604 State Input/Output display.</p>																												
<p>FAULT CONDITIONS:</p>	<p>Pressure switch error count must equal 255.</p>																												
<p>FAULT SET TIME:</p>	<p>For hard faults when super cold = 3.3 seconds For hard faults when cold = 2.2 seconds For hard faults when warm = 1.4 seconds For hard faults when hot = 0.6 second (Temperature description based off of DRB II transaxle state display)</p>																												
<p>EFFECT:</p>	<p>Transmission limp-in.</p>																												
<p>POSSIBLE CAUSES:</p>	<p>Low/high fluid level in transmission. Short/open in LR Pressure Switch circuit, 2/4 Pressure Switch circuit, or OD Pressure Switch circuit. Solenoid pack internal problem. Internal transmission problem. 40-way connector problem (cavities 9, 47, and 50). Internal controller failure.</p>																												



FAULT CODE 28

FAULT CODE:	28 Check Shifter Signal (Bad PRNODL Data)																																													
BACKGROUND:	<p>PRNODL and Neutral/Start switches are used to:</p> <ol style="list-style-type: none"> (1) Determine the Shift Lever Position. (2) Supply a ground to the Starter Relay in Park and Neutral only. (3) Supply a ground to the Backup Lamp Relay in Reverse only. <p>The controller reads the switch signals (from Neutral/Start switch, and from PRNODL switch) according to the table below, which includes two recognized temporary codes that occur while moving Shift Lever Position (SLP).</p> <p style="text-align: center;">Normal PRNODL & Neutral/Start Switch States</p> <table border="1" style="margin-left: auto; margin-right: auto;"> <thead> <tr> <th>SLP</th> <th>T42</th> <th>T41</th> <th>T01</th> <th>T03</th> </tr> </thead> <tbody> <tr> <td>P</td> <td>C</td> <td>C</td> <td>O</td> <td>O</td> </tr> <tr> <td>R</td> <td>O</td> <td>O</td> <td>C</td> <td>C</td> </tr> <tr> <td>N</td> <td>O</td> <td>C</td> <td>C</td> <td>O</td> </tr> <tr> <td>OD</td> <td>O</td> <td>O</td> <td>O</td> <td>C</td> </tr> <tr> <td>D</td> <td>O</td> <td>O</td> <td>C</td> <td>O</td> </tr> <tr> <td>L</td> <td>C</td> <td>O</td> <td>O</td> <td>O</td> </tr> <tr> <td>T1</td> <td>O</td> <td>C</td> <td>O</td> <td>O</td> </tr> <tr> <td>T2</td> <td>O</td> <td>O</td> <td>O</td> <td>O</td> </tr> </tbody> </table> <p style="text-align: center;">O = Switch is open C = Switch is closed</p> <p>When an invalid code is seen, the controller tries to determine Shift Lever Position through hydraulic interpretation (by energizing some solenoids and monitoring the pressure switch responses).</p>	SLP	T42	T41	T01	T03	P	C	C	O	O	R	O	O	C	C	N	O	C	C	O	OD	O	O	O	C	D	O	O	C	O	L	C	O	O	O	T1	O	C	O	O	T2	O	O	O	O
SLP	T42	T41	T01	T03																																										
P	C	C	O	O																																										
R	O	O	C	C																																										
N	O	C	C	O																																										
OD	O	O	O	C																																										
D	O	O	C	O																																										
L	C	O	O	O																																										
T1	O	C	O	O																																										
T2	O	O	O	O																																										
WHEN CHECKED:	Every 0.007 second.																																													
ARMING CONDITIONS:	<ol style="list-style-type: none"> (1) Ignition key turned to the run position. (2) Loss of prime test must not be in progress. (3) CASE 1: PRNODL switch mask inconsistent with normal PRNODL switch state table. (Invalid PRNODL code.) Use DRB II A-604 State Monitor for Shift Lever display. CASE 2: PRNODL data error flag is set due to invalid sequence of old PRNODL data versus new PRNODL data (i.e., instantaneous PRNODL data change from reverse to overdrive or overdrive to reverse.) 																																													
FAULT CONDITIONS:	<p>CASE 1: Invalid code timer has expired (0.1 second).</p> <p>CASE 2: Third occurrence of setting PRNODL data error flag since start-up.</p>																																													
FAULT SET TIME:	<p>CASE 1: 0.1 second.</p> <p>CASE 2: Third occurrence of setting PRNODL data error flag since start-up. This fault case is not time specific.</p>																																													
EFFECT:	No limp-in. However, valid but incorrect PRNODL and Neutral/Start signals (e.g., shift lever is in OD position where R code is being received) might result in other fault codes and possibly a limp-in. This is why it is very important to verify the correctness of the Shift Lever Position signals before diagnosing any problems.																																													
POSSIBLE CAUSES:	<p>Open/short Starter Relay Ground, PRNDL (T42) circuit, Neutral Start Switch circuit, PRNDL (T01) circuit, or Back up Lamp Relay Coil Driver.</p> <p>Open Ignition (+) circuit between Neutral Safety switch and splice.</p> <p>Open ETAX power Ground (B-) circuit between PRNODL switch and splice.</p> <p>Defective or disconnected Neutral Safety or PRNODL switch.</p> <p>Defective or disconnected Backup Lamp Relay.</p> <p>40-way connector problem (cavities 1, 2, 3, 41, and 42).</p> <p>Internal controller failure.</p>																																													

FAULT CODE 29

FAULT CODE:	29 Throttle Position Signal
BACKGROUND:	The EATX controller receives the Throttle Position Signal circuit and its ground (Signal Reference circuit) from the Throttle Position Sensor (TPS). The TPS has a 5-volt pull-up supplied by the engine controller. The throttle signal is checked for out-of-range as well as intermittency (excessive signal changes).
WHEN CHECKED:	Every 0.007 second.
ARMING CONDITIONS:	Engine must be running.
FAULT CONDITIONS:	Throttle angle less than 6 degrees. -OR- Throttle angle greater than 120 degrees.
FAULT SET TIME:	0.6 second.
EFFECT:	No limp-in. A default throttle value is used. No lockup. No 4th gear. Limited shift schedule.
POSSIBLE CAUSES:	Open/shorted Throttle Position Signal circuit. Open Signal Reference circuit. Open 5-volt output (for TPS) circuit between TPS and engine controller. 40-way connector problem. Defective TPS. Defective engine controller. Internal controller failure.

9221-112

FAULT CODE 31-32

FAULT CODE:	31-32 Hydraulic Pressure Switch Failure Code 31 OD Hydraulic Pressure Switch Code 32 2/4 Hydraulic Pressure Switch
BACKGROUND:	The controller tests the OD and 2/4 pressure switches when they are off (i.e., when the corresponding friction element [clutch] is not applied). The test makes sure the switches are operational. The controller verifies that the switch closes when the corresponding element is applied. If a switch fails to respond, it is retested.
WHEN CHECKED:	After a shift is made, periodically thereafter.
ARMING CONDITIONS:	(1) Transmission is at normal operating temperature. (2) Must be in 1st, 2nd or 3rd Gear. (3) Engine rpm fast enough to provide pump pressure (1000 rpm). (4) Acceptable pressure switch fault count (60). (5) Acceptable speed check fault count (80).
FAULT CONDITIONS:	Pressure switch does not respond within specified time for given temperature range.
FAULT SET TIME:	5 seconds.
EFFECT:	Transmission limp-in.
POSSIBLE CAUSES:	Low/high transmission fluid level. Solenoid pack problem. Internal transmission problem.

9221-113

FAULT CODE 36

FAULT CODE:	36 Fault Immediately After Shift
BACKGROUND:	<p>This code is not stored alone. It is stored if a speed error (codes 50 through 58) is detected immediately after shift.</p> <p>The existence of code 36 indicates a mechanical or hydraulic (non-electrical) related problem. It should be noted, however, that all mechanical problems don't necessarily result in code 36.</p> <p>When this code exists, diagnosing the system should be based on the associated code and ONLY mechanical causes should be considered.</p>
WHEN CHECKED:	After a Speed Error code is stored.
ARMING CONDITIONS:	Fault code 50 – 58 (Speed Error) has already been set.
FAULT CONDITIONS:	Fault happened within 1.3 seconds of a shift.
FAULT SET TIME:	Same as associated speed error.
EFFECT:	Same as associated speed error.
POSSIBLE CAUSES:	Internal transmission problem (refer to Speed Errors).

9221-114

FAULT CODE 37

FAULT CODE:	37 Solenoid Switch Valve in the LU Position
BACKGROUND:	<p>The Solenoid Switch Valve (SSV) controls the direction of the transmission fluid when the LR/LU solenoid is energized. Solenoid Switch Valve will be in the downshifted position in 1st gear, thus directing the fluid to the LR element. In 2nd, 3rd and 4th, it will be in the upshifted position and directs the fluid into the Lockup Switch Valve which controls the Torque Converter.</p> <p>When shifting into 1st gear, a special sequence is followed to make sure the Solenoid Switch Valve moves into the downshifted position. LR pressure switch is monitored to confirm Solenoid Switch Valve movement. If Solenoid Switch Valve movement is not confirmed, 2nd gear is substituted for 1st.</p>
WHEN CHECKED:	Prior to a shift into 1st.
ARMING CONDITIONS:	<p>(1) Transmission at normal operating temperature.</p> <p>(2) Solenoid Switch Valve flag must be set.</p>
FAULT CONDITIONS:	Three unsuccessful attempts to shift into 1st gear.
FAULT SET TIME:	Concurrent with the third consecutive unsuccessful attempt to shift into 1st gear.
EFFECT:	<p>No limp-in.</p> <p>No 1st gear (2nd gear is substituted).</p> <p>No lockup operation.</p>
POSSIBLE CAUSES:	Internal transmission problem.

9221-115

FAULT CODE 38

FAULT CODE:	38 Lockup Control (Out of Range)
BACKGROUND:	When in 2nd, 3rd or 4th gear, the torque converter can be locked when certain conditions are met. The LU piston is modulated (partial lockup) by modulating the LR/LU solenoid until the torque converter slip (difference between engine and turbine rpm) is within a desired range. Then the LR/LU solenoid is fully energized (full lockup).
WHEN CHECKED:	When in partial lockup.
ARMING CONDITIONS:	(1) In partial lockup. (2) Turbine speed greater than 1750 rpm. (3) Transmission temperature not cold or warm. (4) Brake not on. (5) PRNODL is in 'OD' position.
FAULT CONDITIONS:	Partial lock fault counter equals 255.
FAULT SET TIME:	7 seconds.
EFFECT:	No limp-in. Lockup operation is not allowed.
POSSIBLE CAUSES:	Low/high transmission fluid. Internal transmission problem.



FAULT CODE 41-44

FAULT CODE:	41-44 Solenoid Continuity Test Failure Code 41 LR Solenoid Circuit Code 42 2/4 Solenoid Circuit Code 43 OD Solenoid Circuit Code 44 UD Solenoid Circuit
BACKGROUND:	Four Solenoids are used to control the friction elements (clutches). The continuity of the solenoid circuits is tested periodically. Each solenoid is turned off and an inductive voltage spike should be detected. When no spike is detected, the solenoid circuits are tested a second time to verify the failure. In addition to the periodic testing, solenoid circuits are tested when a speed or pressure switch circuit error occurs. In this case, one failure will result in setting the appropriate code.
WHEN CHECKED:	After a reset, then every 10 seconds thereafter. When a speed error or pressure switch mismatch is detected.
ARMING CONDITIONS:	(1) Shift not in progress. (2) Shift Lever Position Test not in progress. (3) Pressure Switch Test not in progress. (4) Watchdog Test not in progress. (5) No voltage spike detected from solenoid during first test.
FAULT CONDITIONS:	Solenoid Continuity Test failed for the second time. – OR – Either a pressure switch or speed data problem and Solenoid Continuity Test failed for the first time.
FAULT SET TIME:	Without Speed or Pressure Switch error 12.0 seconds. – OR – With Speed error 0.2 second. – OR – With Pressure Switch error Super Cold: 3.0 seconds Cold: 2.0 seconds Warm: 1.2 seconds Hot: 0.5 second (Temperature description based off of DRB II transaxle state display.)
EFFECT:	Transmission limp-in.
POSSIBLE CAUSES:	Open/shorted LR Solenoid Driver circuit, 2/4 Solenoid Driver circuit, UD Solenoid Driver circuit and OD Solenoid Driver circuit. Open Power Ground circuit. 60-way connector problem (cavities 16, 17, 19, 20, 57, 58, 59, and 60). 8-way connector problem (cavities 4, 5, 6, 7, and 8). Solenoid Pack internal problem. Internal controller failure.

FAULT CODE 45

FAULT CODE:	45 Internal Controller (EEPROM Byte Failure)
BACKGROUND:	<p>The transmission system supports several engine models, each requiring different shift schedules and calibration constants. The EATX controller receives the engine model code from the engine controller and stores it in the microprocessor's EEPROM memory. Once the engine model code is established in the EEPROM memory, it is used to select the appropriate shift schedule and other calibrations.</p> <p>The EEPROM memory location used for the engine model code is checked to make sure it can hold data. If the EEPROM memory location fails the checks, the code is set.</p>
WHEN CHECKED:	After a reset (ignition key turned to the RUN position or after cranking engine).
ARMING CONDITIONS:	<p>(1) No write request to EEPROM.</p> <p>(2) Engine model not erased from transaxle controller memory.</p>
FAULT CONDITIONS:	Engine model stored in EEPROM is different from data stored in RAM.
FAULT SET TIME:	14 seconds.
EFFECT:	No limp-in.
POSSIBLE CAUSES:	Internal controller failure.

9221-118X

FAULT CODE 46

FAULT CODE:	46 3/4 Shift Abort (UD Hydraulic Circuit Failure)																																																
BACKGROUND:	<p>The following table shows the clutches applied in each gear:</p> <table border="1" data-bbox="581 1213 1344 1495"> <thead> <tr> <th>Gear</th> <th>UD</th> <th>OD</th> <th>REV.</th> <th>2/4</th> <th>LR</th> </tr> </thead> <tbody> <tr> <td>Park</td> <td></td> <td></td> <td></td> <td></td> <td>X</td> </tr> <tr> <td>Reverse</td> <td></td> <td></td> <td>X</td> <td></td> <td>X</td> </tr> <tr> <td>Neutral</td> <td></td> <td></td> <td></td> <td></td> <td>X</td> </tr> <tr> <td>1st</td> <td>X</td> <td></td> <td></td> <td></td> <td>X</td> </tr> <tr> <td>2nd</td> <td>X</td> <td></td> <td></td> <td>X</td> <td></td> </tr> <tr> <td>3rd</td> <td>X</td> <td>X</td> <td></td> <td></td> <td></td> </tr> <tr> <td>4th</td> <td></td> <td>X</td> <td></td> <td>X</td> <td></td> </tr> </tbody> </table> <p>When shifting from 3rd to 4th gear, a delayed speed change will indicate a problem in the UD hydraulic circuit. When this is detected, the 3/4 shift is aborted temporarily. The controller will attempt the 3/4 shift again. After three unsuccessful shift attempts, the code is set.</p>	Gear	UD	OD	REV.	2/4	LR	Park					X	Reverse			X		X	Neutral					X	1st	X				X	2nd	X			X		3rd	X	X				4th		X		X	
Gear	UD	OD	REV.	2/4	LR																																												
Park					X																																												
Reverse			X		X																																												
Neutral					X																																												
1st	X				X																																												
2nd	X			X																																													
3rd	X	X																																															
4th		X		X																																													
WHEN CHECKED:	Prior to the 3/4 shift.																																																
ARMING CONDITIONS:	<p>(1) Must be doing a 3/4 shift.</p> <p>(2) Under Drive Failure flag must be set. (Temperature must not be cold.)</p>																																																
FAULT CONDITIONS:	Under Drive Fault Counter is greater than three.																																																
FAULT SET TIME:	Concurrent with the third consecutive 3/4 shift abort.																																																
EFFECT:	No limp-in.																																																
POSSIBLE CAUSES:	Internal transmission failure.																																																

9221-119

FAULT CODE 47

FAULT CODE:	47 Solenoid Switch Valve in LR Position
BACKGROUND:	<p>The Solenoid Switch Valve (SSV) controls the direction of the transmission fluid when the LR/LU solenoid is energized. Solenoid Switch Valve will be in the downshifted position in 1st gear, thus directing the fluid to the LR element. In 2nd, 3rd, and 4th, it will be in the upshifted position and directs the fluid into the Lockup Switch Valve which controls the Torque Converter.</p> <p>When doing partial lockup or full lockup, the LR pressure switch should indicate no pressure if Solenoid Switch Valve is in the LU position. If LR pressure switch indicates pressure for some time while in partial or full lockup, lockup operation is stopped to avoid accidental application of the LR clutch.</p> <p>Partial lockup is attempted when there is no LR pressure. A second detection of LR pressure will result in setting the fault code and a shutdown.</p>
WHEN CHECKED:	Continuously when doing partial or full lockup.
ARMING CONDITIONS:	Must be in partial or full lockup.
FAULT CONDITIONS:	LR pressure is high for the second time.
FAULT SET TIME:	1.5 seconds (minimum). 2.6 seconds (maximum).
EFFECT:	Transmission limp-in.
POSSIBLE CAUSES:	Internal transmission problem.



FAULT CODE 50-58

FAULT CODE:	50-58 Speeds Error Code 50 Gear Ratio in Reverse Code 51 Gear Ratio in 1st Code 52 Gear Ratio in 2nd Code 53 Gear Ratio in 3rd Code 54 Gear Ratio in 4th Code 55 (Not Used) Code 56 Turbine Speed Sensor Code 57 Output Speed Sensor Code 58 Speed Sensors' Ground
BACKGROUND:	The system uses two speed sensors, one for turbine rpm and the other for output rpm. These inputs are very essential for transaxle operation. Therefore, the integrity of this data is verified through the following checks: (1) When in gear, if the ratio of the turbine rpm speed sensor to the output rpm speed sensor doesn't compare to a known gear ratio, the corresponding in-gear fault code is set (50 through 54). (2) An excessive change in turbine or output speeds indicating signal intermittency will result in codes 56 and 57 respectively. (3) After a reset in neutral, observing a certain turbine rpm speed sensor or output rpm speed sensor ratio indicates a loss of the common speed sensors ground which sets code 58. Note: When any of these codes is set immediately after a shift, code 36 will also be set which indicates mechanical hydraulic problems (see code 36).
WHEN CHECKED:	Continuously when transmission is in gear.
ARMING CONDITIONS:	(1) Must not be extremely cold. (2) Engine must be running. (3) Delay after start-up must be greater than 0.3 second. (4) Shift must not be in progress. (5) Engine speed is greater than 500 rpm. (6) Codes 50 through 54 In-Gear Ratio Error. The ratio of the Turbine rpm speed sensor to the output rpm speed sensor doesn't compare to the particular gear ratio. Code 56 Turbine Speed Sensor An excessive change in turbine rpm speed sensor in any gear. Code 57 Output Speed Sensor An excessive change in output rpm speed sensor in any gear. Code 58 Sensors Ground After a reset in Neutral and Turbine speed sensor or Output speed sensor equals a ratio of turbine gear teeth to output gear teeth of 2:50.
FAULT CONDITIONS:	A hard fault is considered to exist when the fault counter has matured to a value of 255. An intermittent fault is considered to be present when the fault counter is greater than or equal to 6 and less than 255. No fault is considered to exist when the fault counter is less than 6.
FAULT SET TIME:	If hard fault speed signal(s): If cold: 2.7 seconds If intermittent speed signal(s): 15.0 seconds If not cold: 1.2 seconds
EFFECT:	Transmission limp-in. Solenoid circuits are tested and, if they fail, are blamed for the speeds error. Shifts are inhibited. Lockup operation is inhibited.

POSSIBLE CAUSES:	Speed Error Code									
	50	51	52	53	54	55	56	57	58	
Open/shorted Output Speed Sensor Circuit	X	X								
Defective Output Sensor	X	X						X		
Output Sensor Connector Problem	X	X						X		
40-way Connector Problem Cavity 13	X	X					X	X		
Cavity 14	X	X						X		
Cavity 52	X	X					X			
Open/shorted Turbine Speed Sensor Circuit	X	X								
Defective Turbine Sensor	X	X					X			
Turbine Sensor Connector Problem	X	X					X			
Open Output Sensor Ground Circuit										X
Internal Controller Failure	X	X					X	X	X	
Internal Transmission Problem	X	X	X	X	X					

FAULT CODE 60-63

FAULT CODE:	60-63 Inadequate Element Volumes Code 60 Inadequate LR Element Volume Code 61 Inadequate 2/4 Element Volume Code 62 Inadequate OD Element Volume Code 63 Inadequate UD Element Volume
BACKGROUND:	The volumes of the transmission fluid needed to apply the friction elements are continuously monitored and learned for adaptive controls. As the friction material wears, the volume of fluid needed to apply the element increases. The following are the typical A-604 clutch volumes (in 3) beyond which the clutches might be damaged: LR: 35-83 OD: 75-150 2/4: 20-77 UD: 24-70 However, certain transmission mechanical problems (such as broken return spring, out-of-position snap ring, etc.) can cause near-zero learned volumes resulting in setting the appropriate code.
WHEN CHECKED:	When volumes are updated: LR: When doing a 2/1 or 3/1 shift. 2/4: When doing a 1/2 shift. OD: When doing a 2/3 shift. UD: When doing a 4/3 or 4/2 shift.
ARMING CONDITIONS:	None.
FAULT CONDITIONS:	The updated learned volume is below a threshold value.
FAULT SET TIME:	Less than 1 second.
EFFECT:	No limp-in.
POSSIBLE CAUSES:	Internal transmission problem.

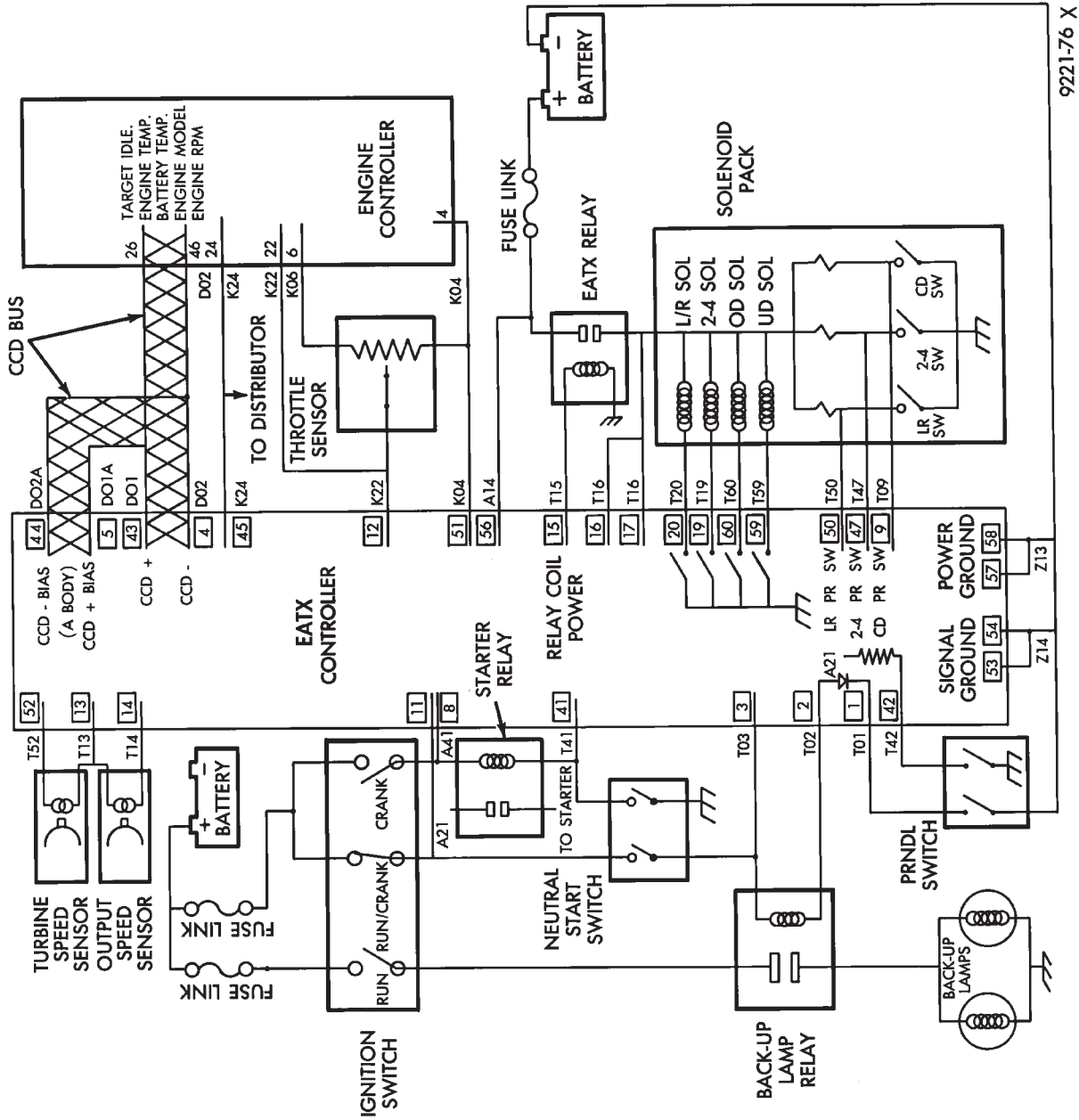

9221-76 X

4 SPEED ELECTRONIC TRANSAXLE WIRING DIAGRAM

PIN NO.	CIRCUIT	WIRE COLOR
1	T01	LG/*
2	T02	TN/BK
3	T03	VT
4	D02	WT/BK
5	D01A	VT/BR
6	K44	TN/YL
7	BLANK	BLANK
8	A41	YL
9	T09	OR/BK
10	BLANK	BLANK
11	A21	DB
12	K22	OR/DB
13	T13	DB/BK
14	T14	LG/WT
15	T15	LG
16	T16	RD
17	T16	RD
18	BLANK	BLANK
19	T19	WT
20	T20	LB
41	T41	BR/YL
42	T42	VT/*
43	D01	VT/BR
44	D02A	WT/BK
45	K24	GR/BK
46	BLANK	BLANK
47	T47	YL/BK
48	BLANK	BLANK
49	BLANK	BLANK
50	T50	DG
51	K04	BK/LB
52	T52	RD/BK
53	Z14	BK/YL
54	Z14	BK/YL
55	BLANK	BLANK
56	A14	RD/*
57	Z13	BK/RD
58	Z13	BK/RD
59	T59	PK
60	T60	BR

ON BOARD DIAGNOSTICS GLOSSARY

ACCESS	The ability to get information or use a computer or program.
ADDRESS	Designates the location of an item of information stored in the computer's memory.
CCD	Acronym for Chrysler Collision Detection System. The system used to communicate between controllers (also called BUS).
CHIP	A term for the integrated circuit and its package which contains coded information.
DATABASE	A large amount of data stored in a well-organized format. A database management system is a program that allows access to the information.
EATX	Acronym for Electronic Automatic Transaxle.
EEPROM	A computer chip which contains memory that can be reprogrammed or erased without removal from circuit board.
ERROR FLAG	An indicator within the controller which tells the controller of a problem.
FAULT COUNTER	A counter within the controller which must reach a predetermined value before a fault code is stored into memory.
KNOWN CONSTANTS	A predetermined value used by the controller.
LEARNED VALUES	Quantities that are adjusted by the controller to compensate for electrical or mechanical variables in a system.
MEMORY	The internal device within the controller used for the storage of information.
MICROPROCESSOR	The control or processing portion of a controller.
PRESSURE SWITCH CIRCUITS	An electrical switch in the hydraulic circuit used to monitor fluid pressures.
PRESSURE SWITCH TEST	A series of tests used to check pressure switch operation.
RAM	An acronym for Random Access Memory. A type of memory which allows the information in it to be modified.
ROM	An acronym for Read Only Memory. A type of memory which does not allow the information to be modified.
SHIFT LEVER POSITION TEST	A test performed by the controller used to determine the position of the shifter.
SOLENOID PACK	A group of four solenoids and three pressure switches. They are used to control and monitor hydraulic fluid within the transaxle.
SWITCHED BATTERY	A term for EATX relay output.
THRESHOLD	A value used to determine if a failure has occurred.
WATCHDOG (WD) CIRCUIT	A circuit in the controller used to monitor the microprocessor within the controller for any problems.



THREE SPEED TRANSAXLE HYDRAULIC SCHEMATICS

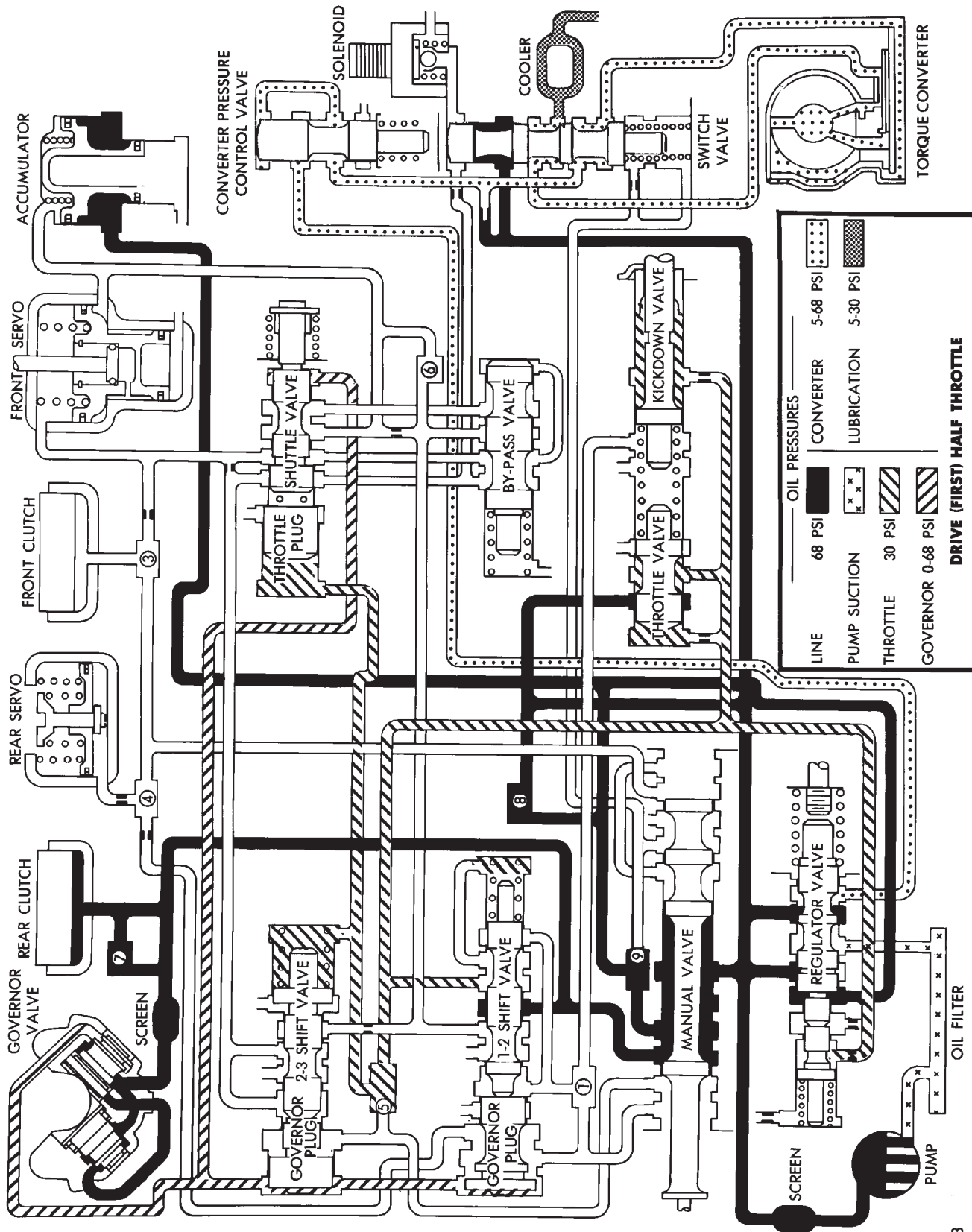

THREE SPEED TRANSAXLE HYDRAULIC SCHEMATIC

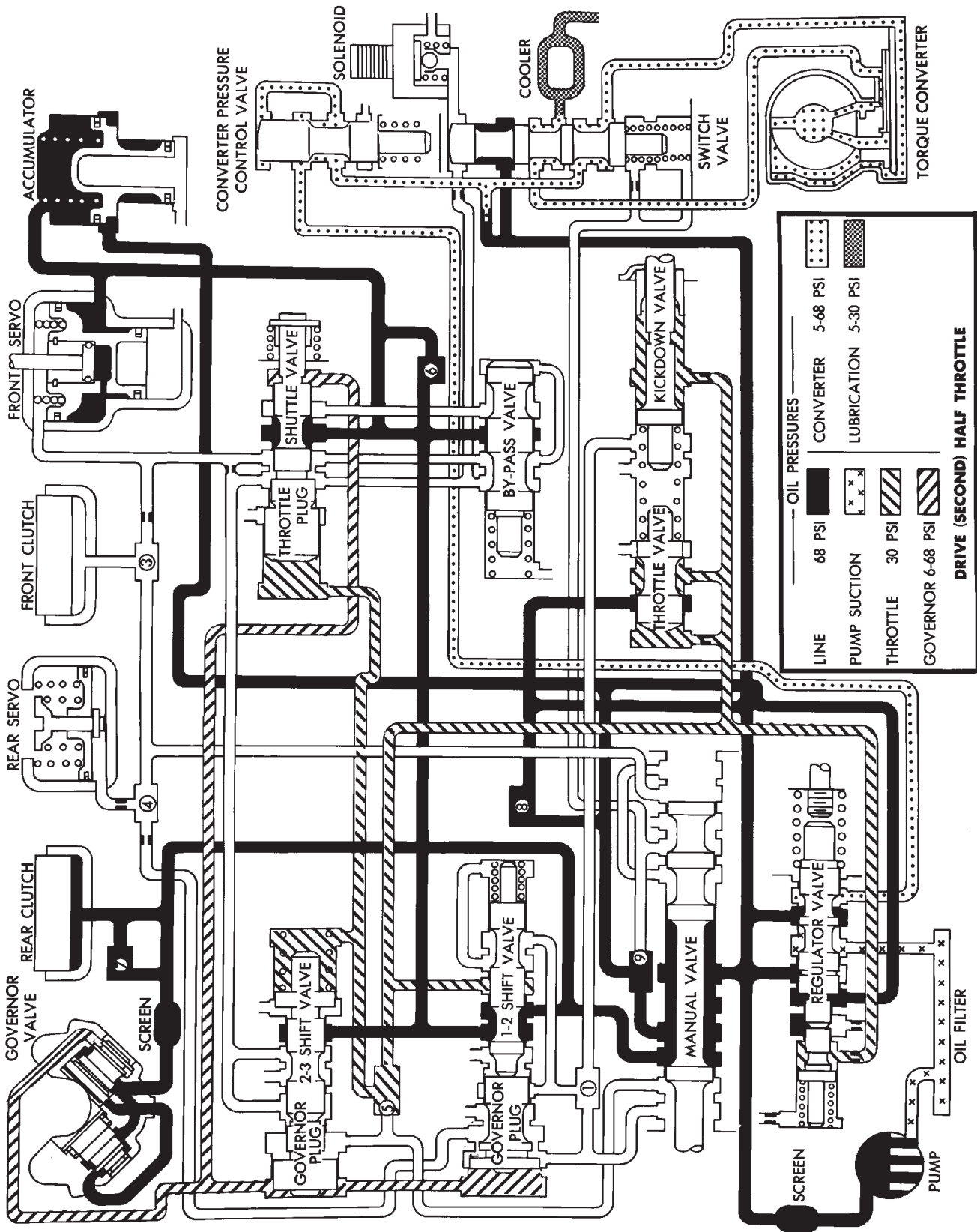

THREE SPEED TRANSAXLE HYDRAULIC SCHEMATIC

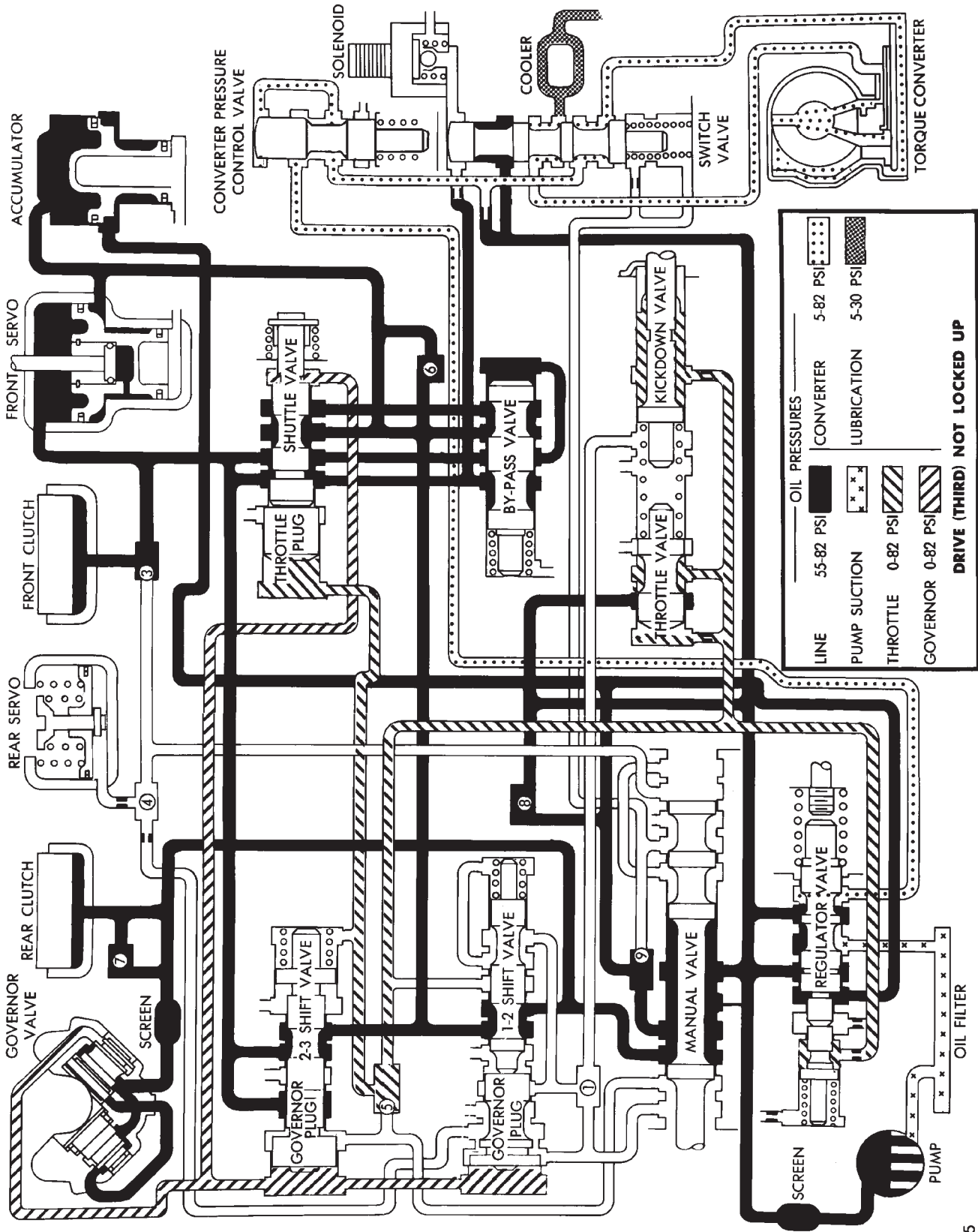

THREE SPEED TRANSAXLE HYDRAULIC SCHEMATIC

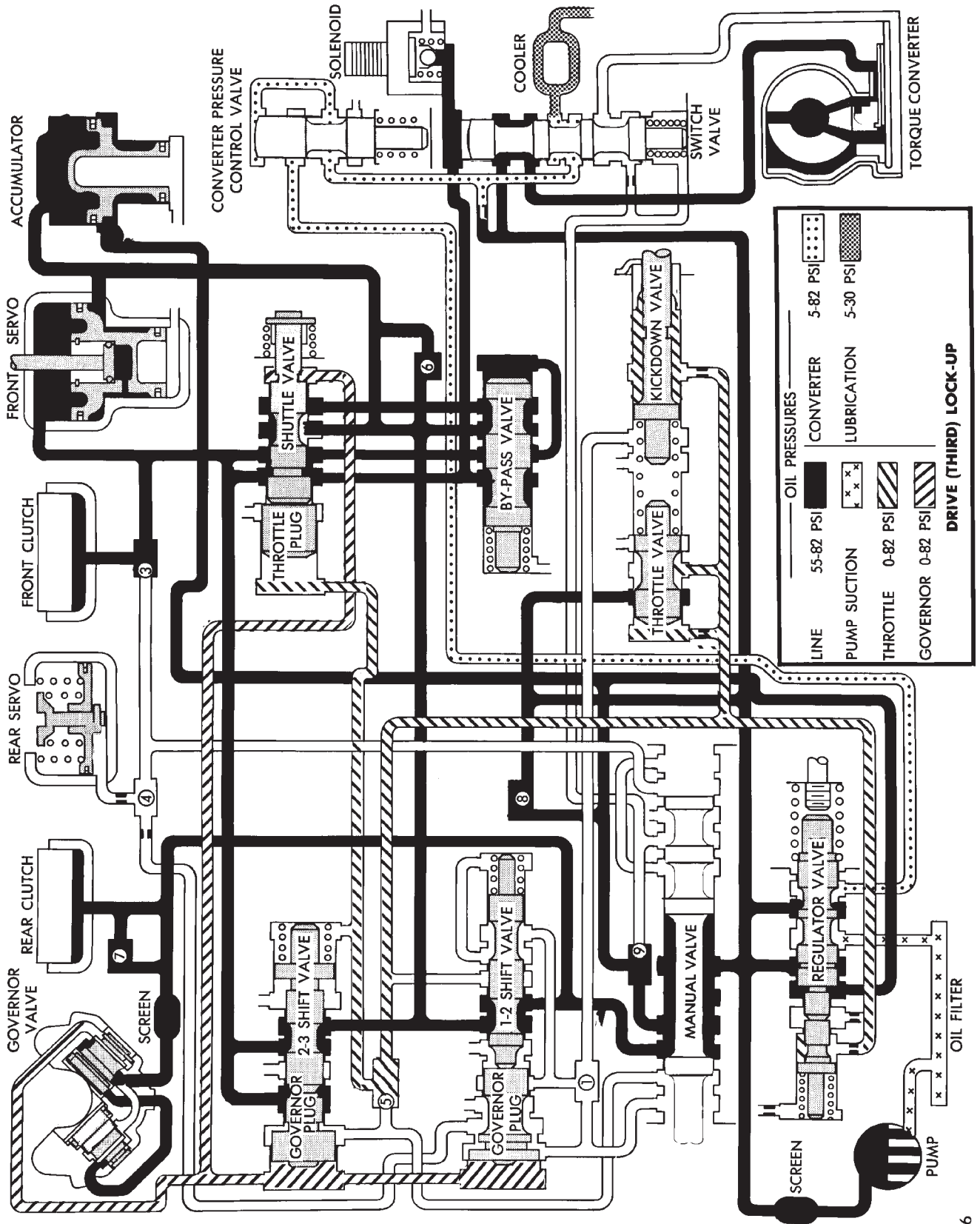

THREE SPEED TRANSAXLE HYDRAULIC SCHEMATIC

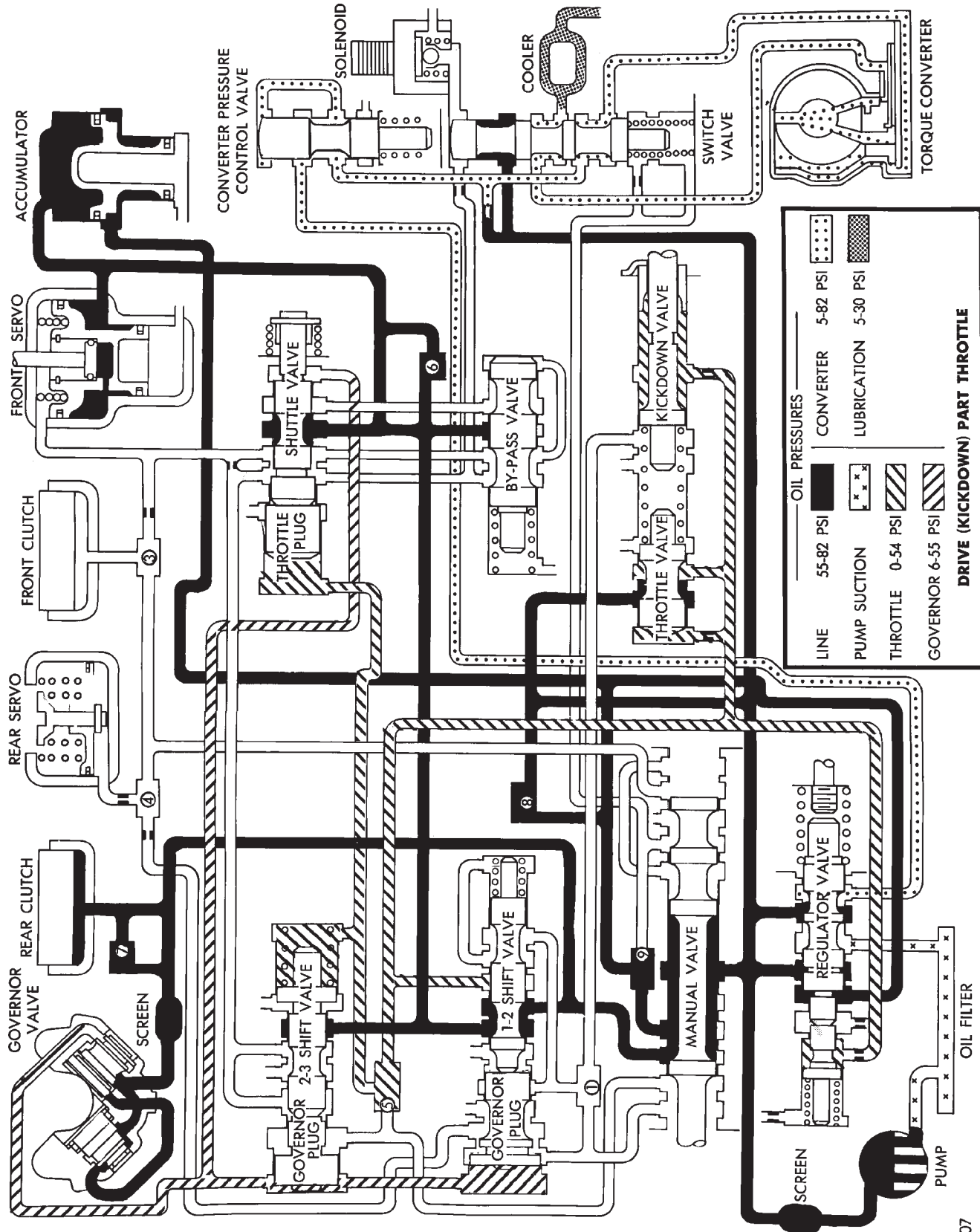

9121-207

THREE SPEED TRANSAXLE HYDRAULIC SCHEMATIC

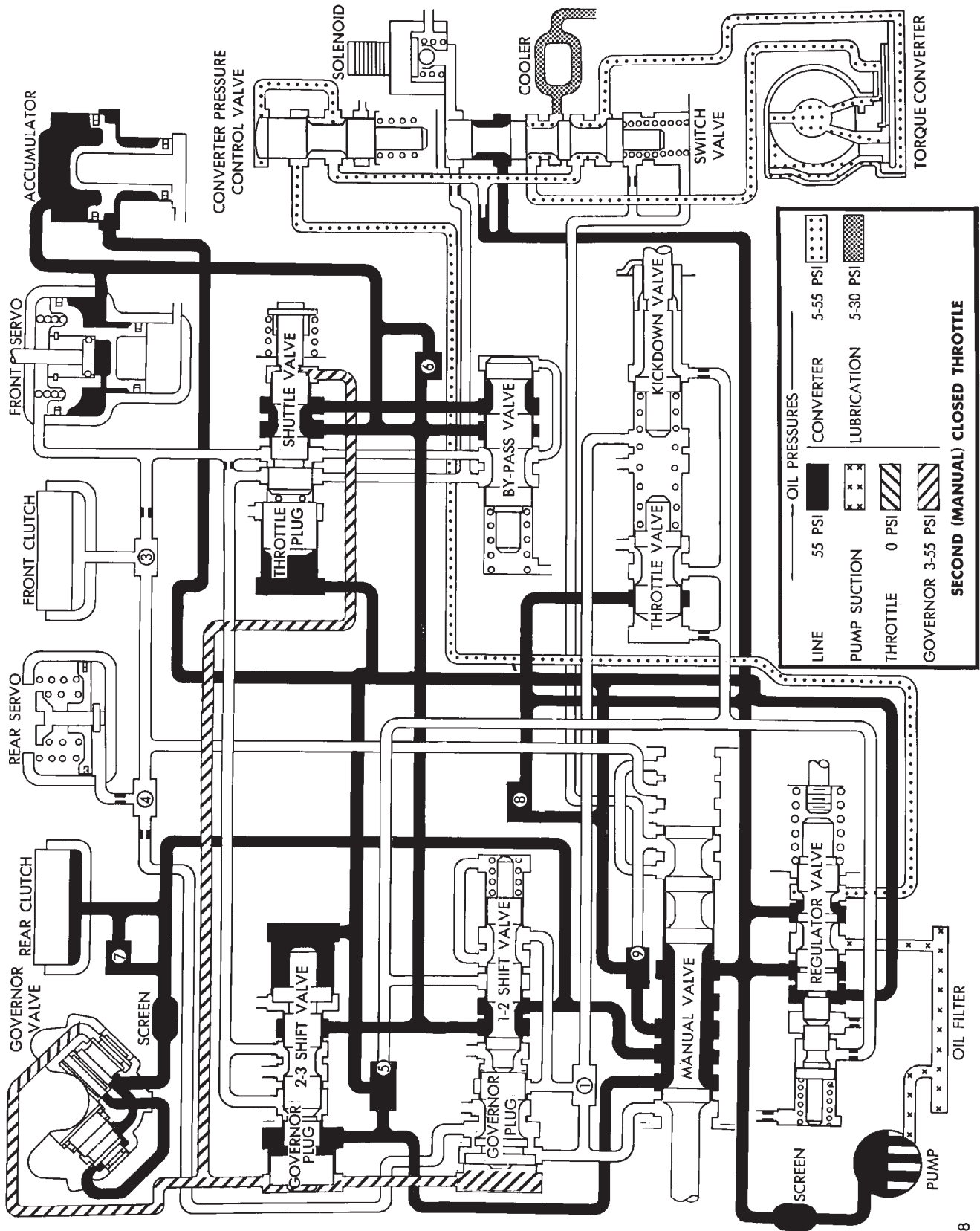

THREE SPEED TRANSAXLE HYDRAULIC SCHEMATIC

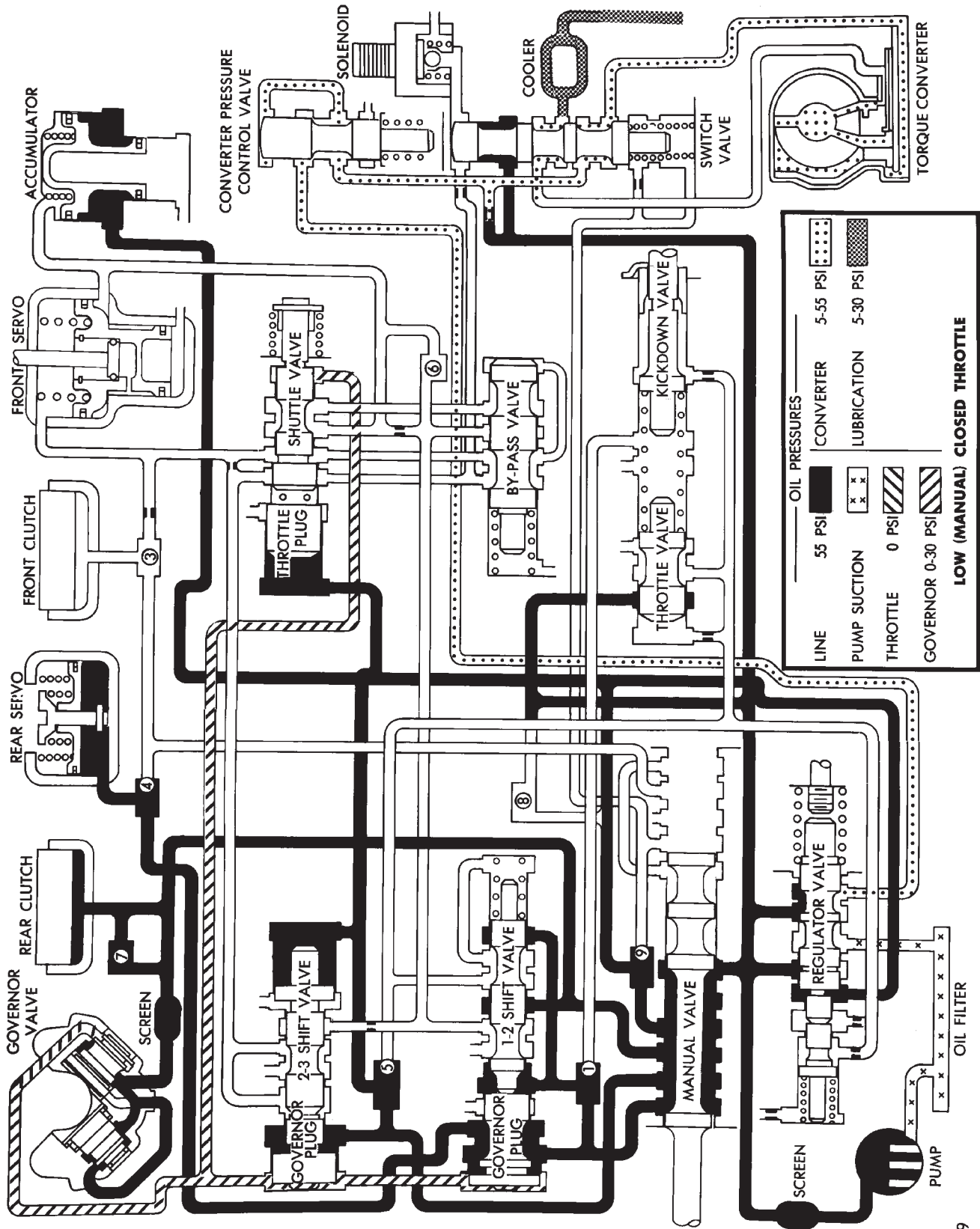

9121-209

THREE SPEED TRANSAXLE HYDRAULIC SCHEMATIC

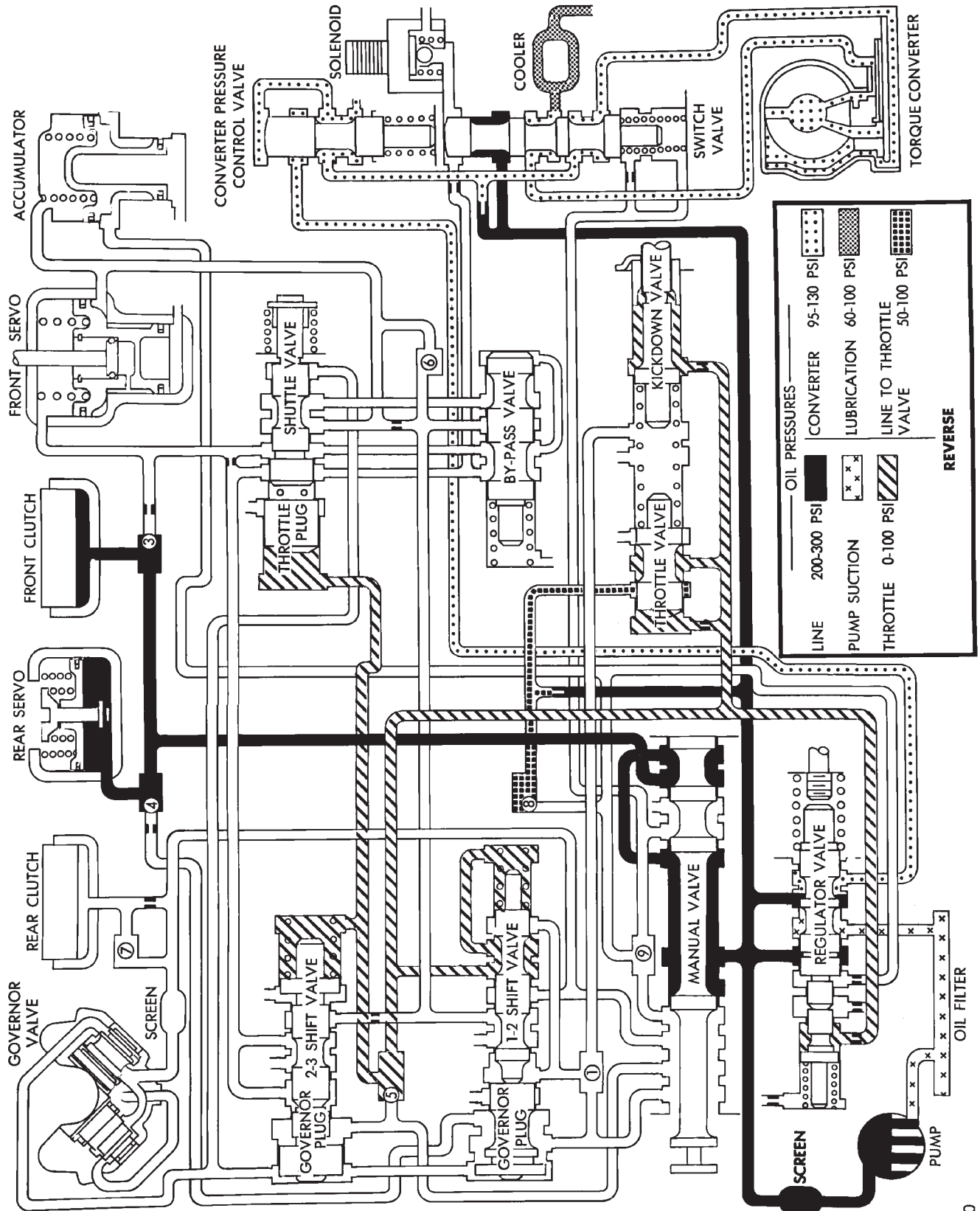

THREE SPEED TRANSAXLE HYDRAULIC SCHEMATIC



4 SPEED ELECTRONIC TRANSAXLE HYDRAULIC SCHEMATICS

9221-78

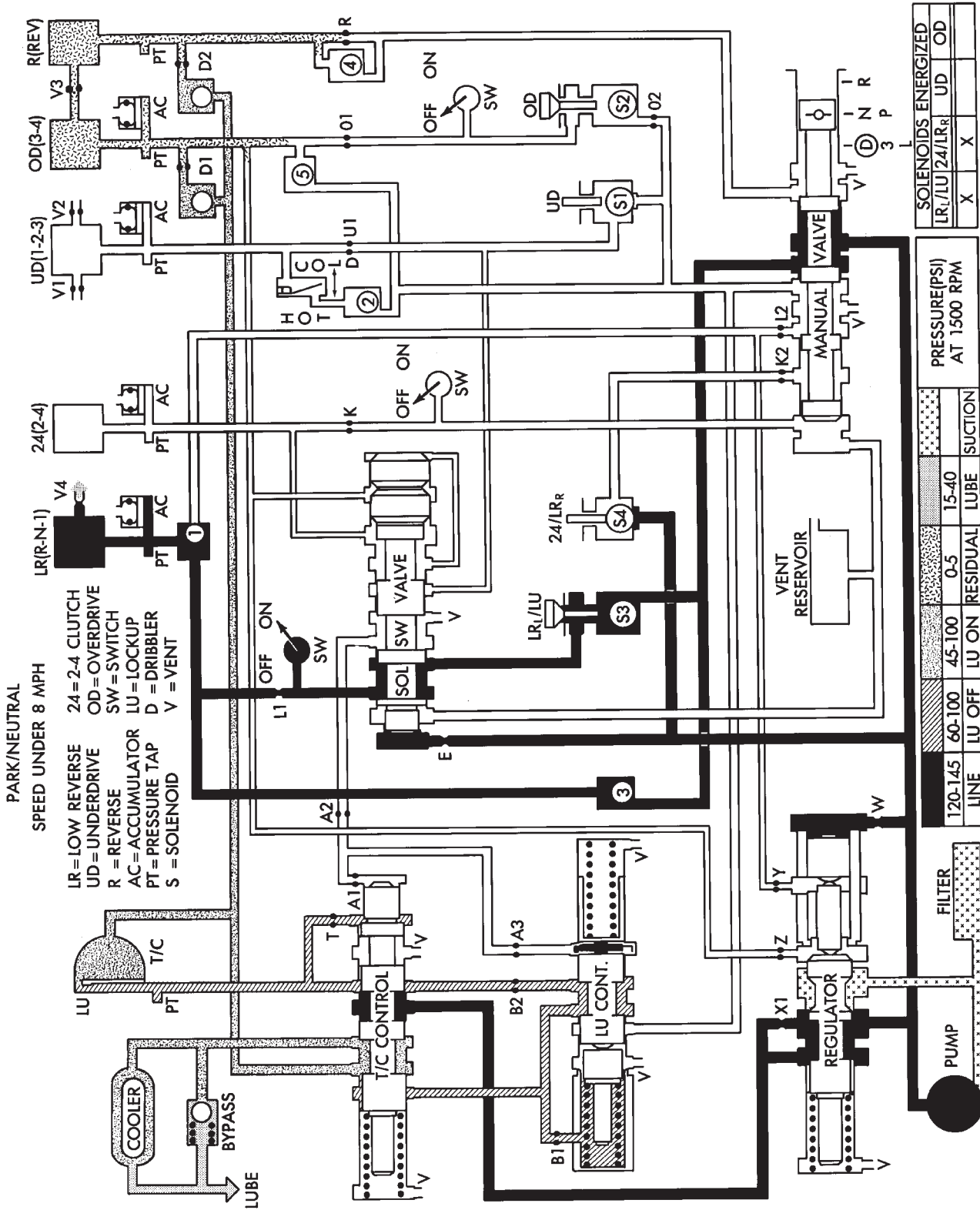

4-SPEED ELECTRONIC TRANSAXLE HYDRAULIC SCHEMATIC



9221-79

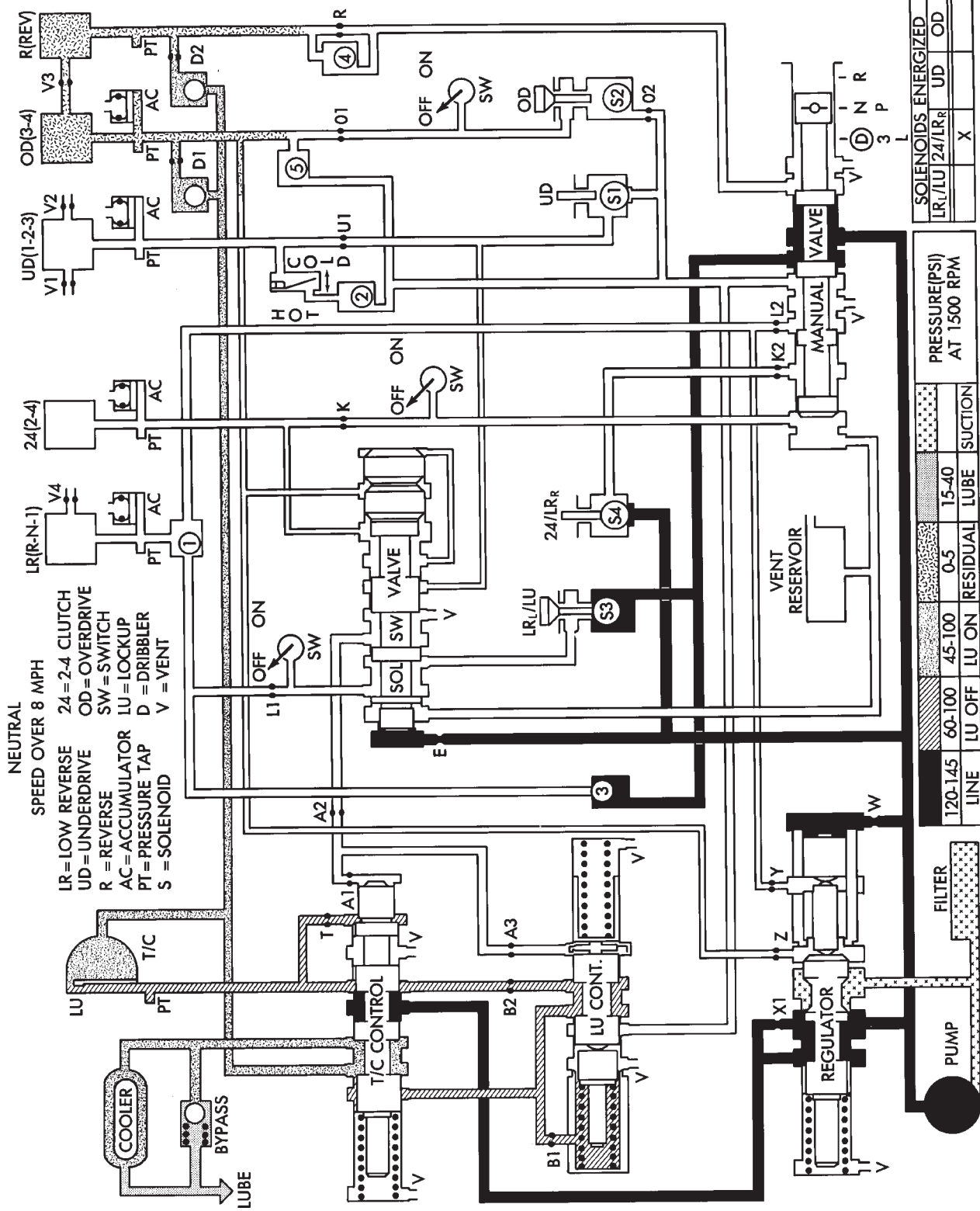

4-SPEED ELECTRONIC TRANSAXLE HYDRAULIC SCHEMATIC

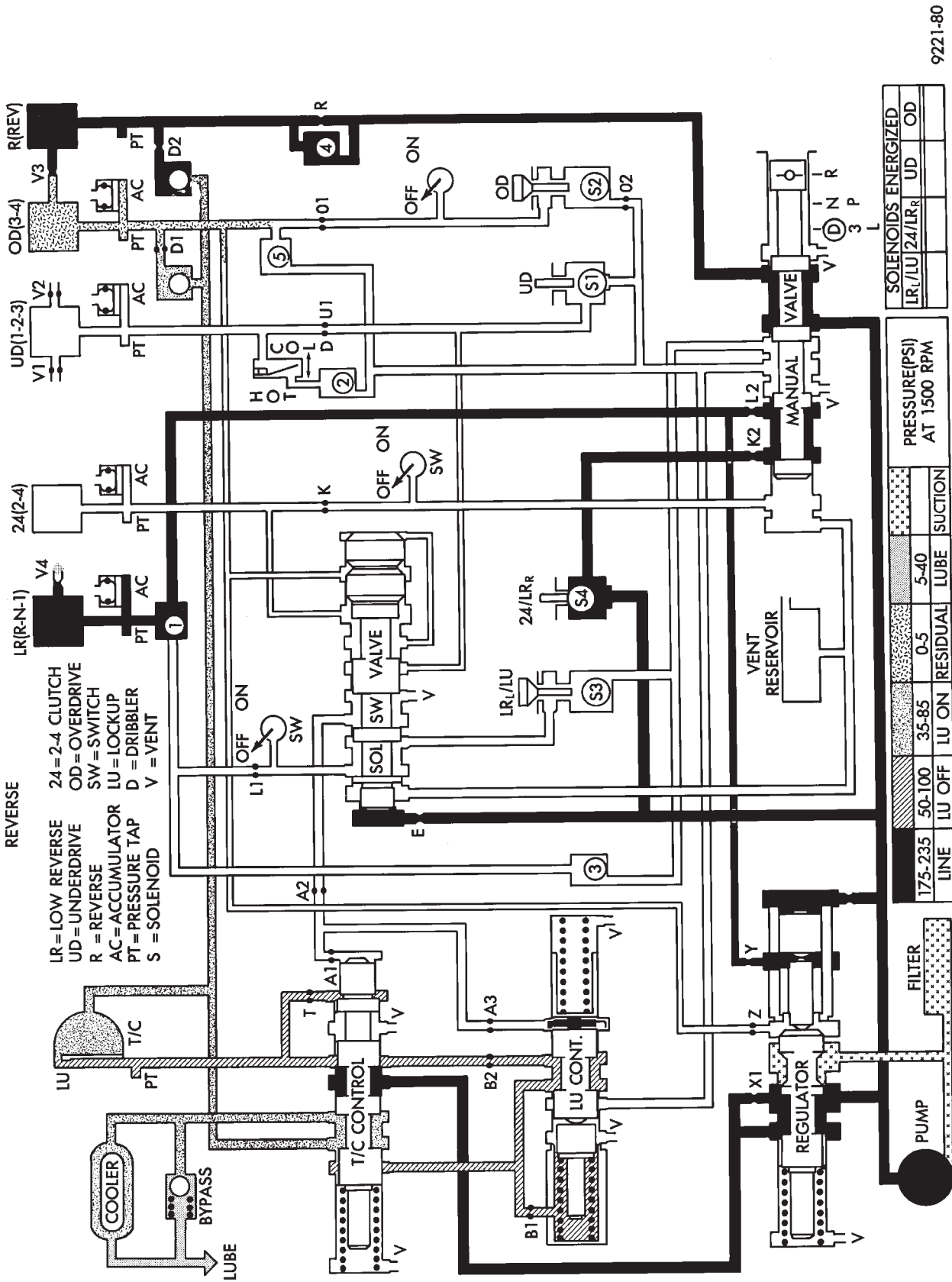

9221-80

4 SPEED ELECTRONIC TRANSAXLE HYDRAULIC SCHEMATIC



REVERSE BLOCK

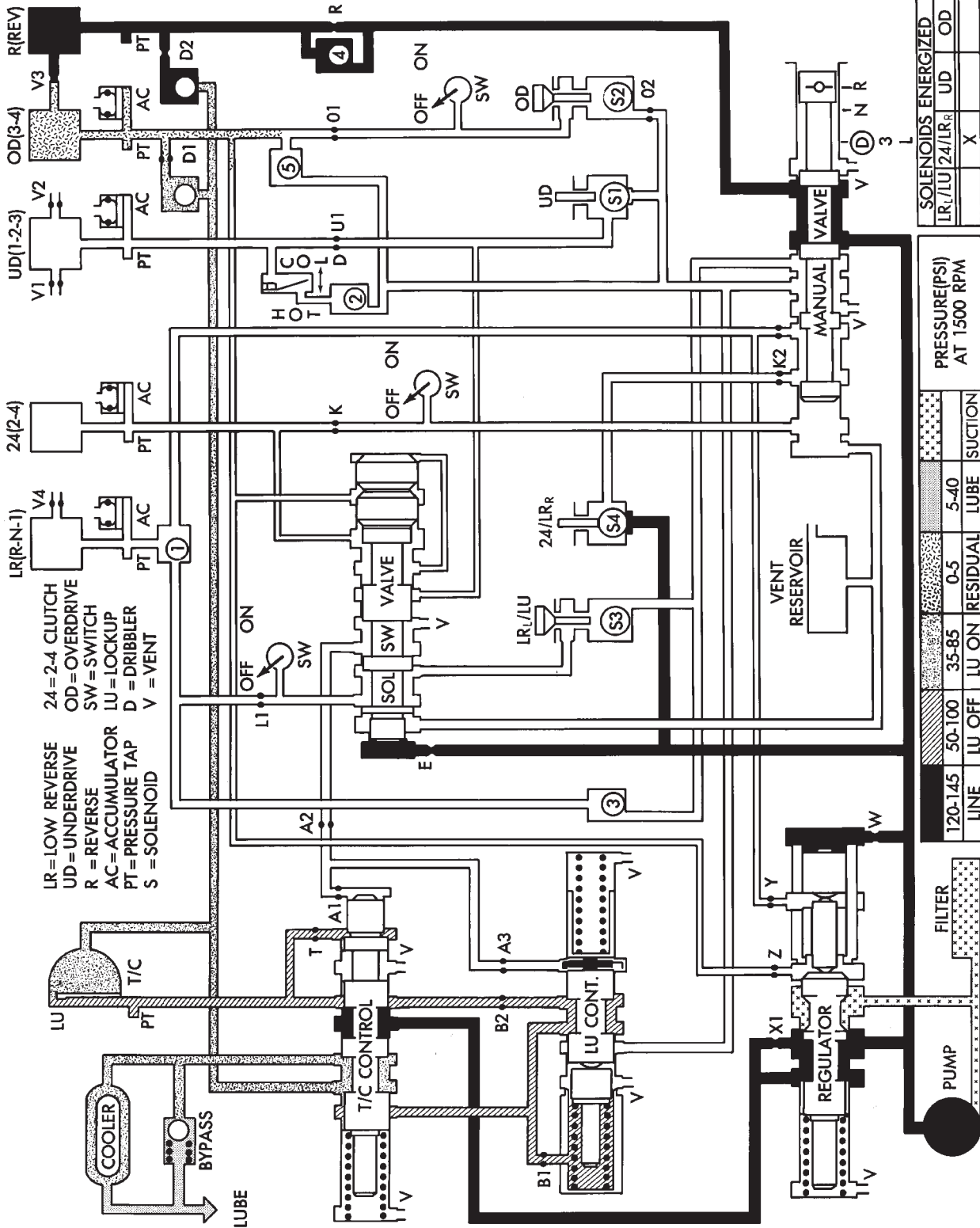

9221-81

SOLENOIDS ENERGIZED			
LR, LU	24/LR _r	UD	OD
		X	
PRESSURE (PSI) AT 1500 RPM			
120-145	50-100	35-85	0-5
LINE	LU OFF	LU ON	RESIDUAL
			LUBE
		5-40	SUCTION

4 SPEED ELECTRONIC TRANSAXLE HYDRAULIC SCHEMATIC



FIRST GEAR

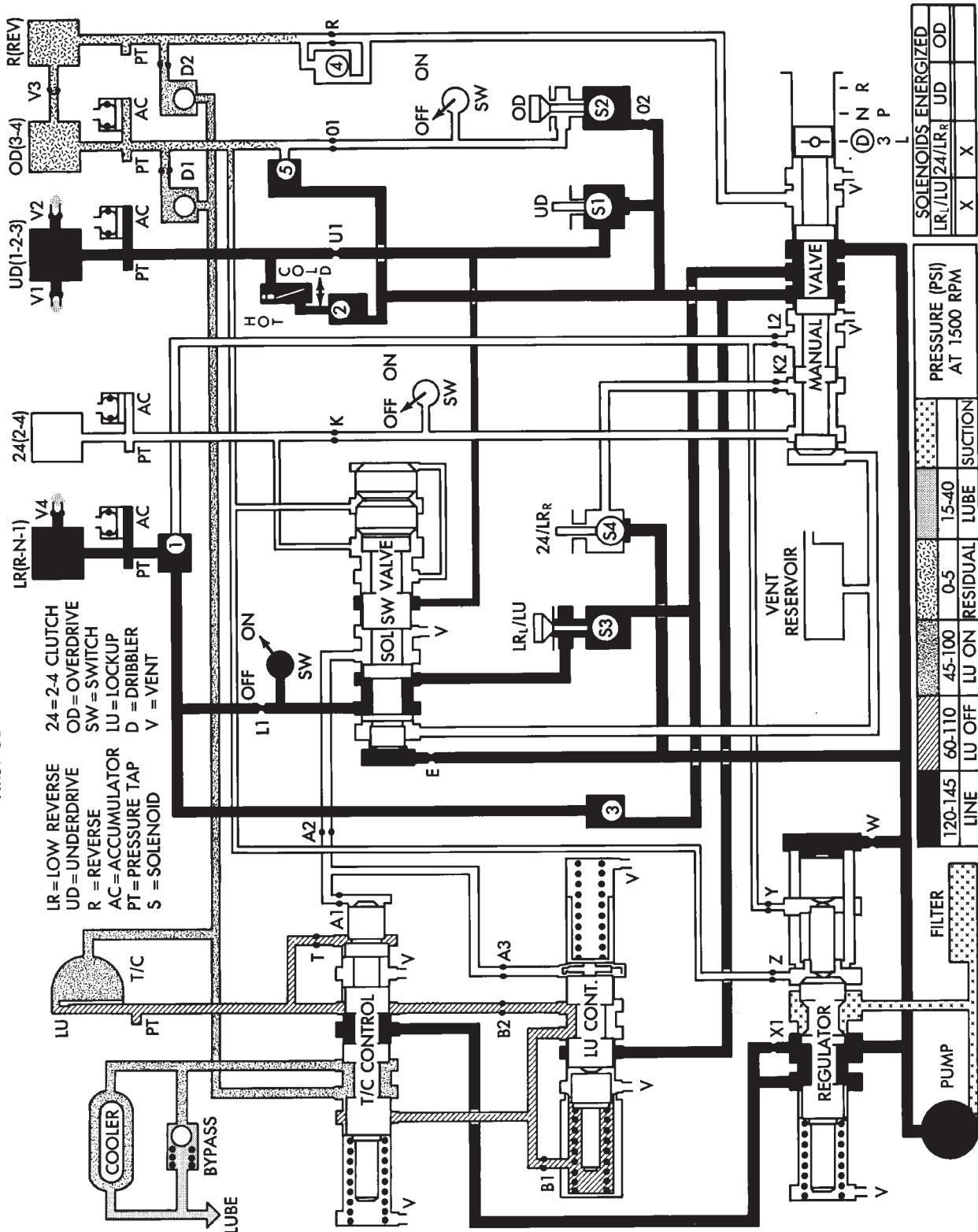

LR = LOW REVERSE
 UD = UNDERDRIVE
 R = REVERSE
 AC = ACCUMULATOR
 PT = PRESSURE TAP
 S = SOLENOID

24 = 2-4 CLUTCH
 OD = OVERDRIVE
 SW = SWITCH
 LU = LOCKUP
 D = DRIBBLER
 V = VENT

SOLENOIDS ENERGIZED			
LR _L /LU	24/LR _R	UD	OD
X	X		

PRESSURE (PSI) AT 1500 RPM			
LU OFF	LU ON	RESIDUAL	LUBE SUCTION
120-145	60-110	45-100	0-5
LINE	LU OFF	LU ON	RESIDUAL

SOLENOIDS ENERGIZED			
LR _L /LU	24/LR _R	UD	OD
X	X		

9221-82

4 SPEED ELECTRONIC TRANSAXLE HYDRAULIC SCHEMATIC



9221-83

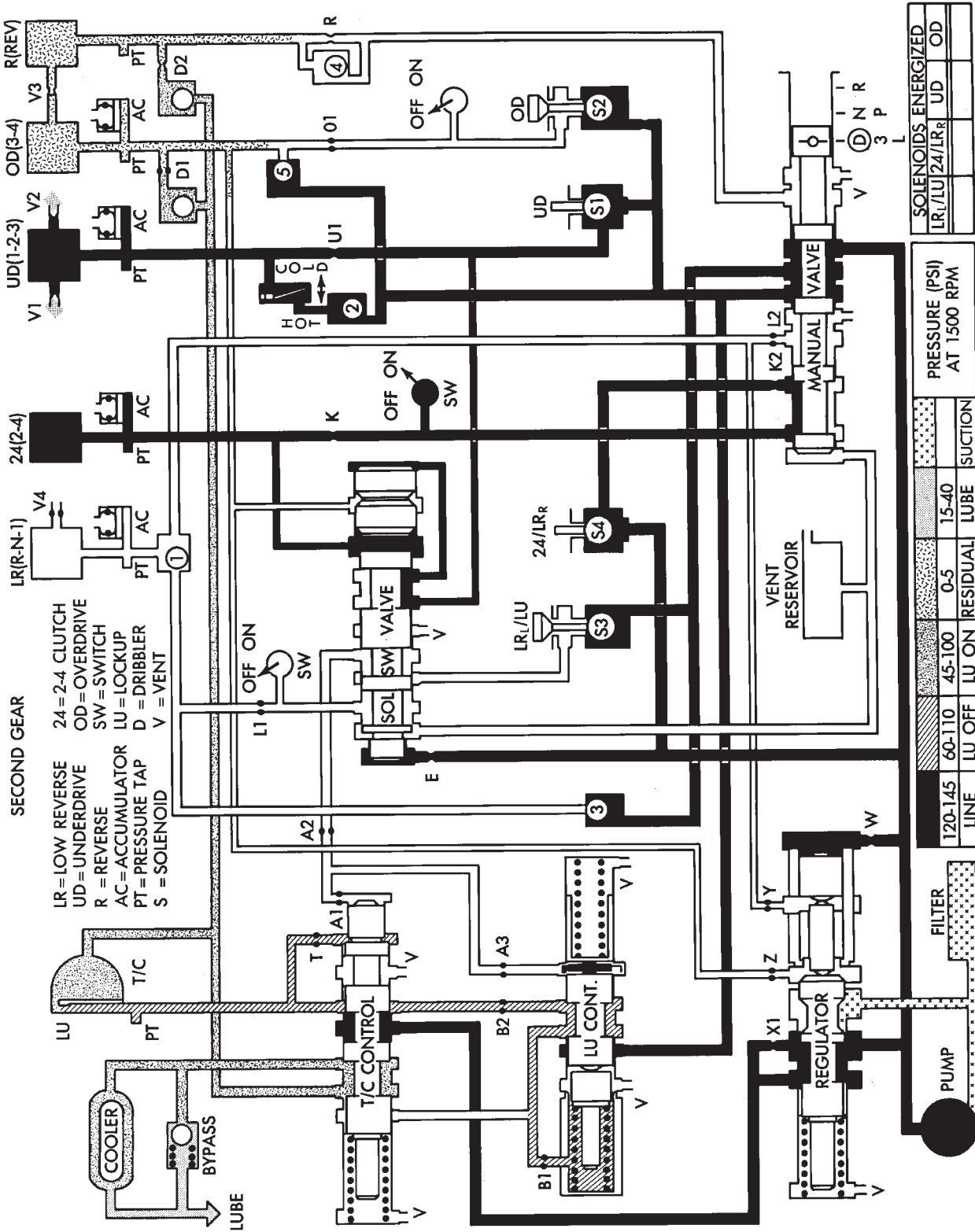

4 SPEED ELECTRONIC TRANSAXLE HYDRAULIC SCHEMATIC



SECOND GEAR

PARTIAL LOCKUP

- LR = LOW REVERSE
- UD = UNDERDRIVE
- R = REVERSE
- AC = ACCUMULATOR
- PT = PRESSURE TAP
- S = SOLENOID
- 24 = 2-4 CLUTCH
- OD = OVERDRIVE
- SW = SWITCH
- LU = LOCKUP
- D = DRIBBLER
- V = VENT

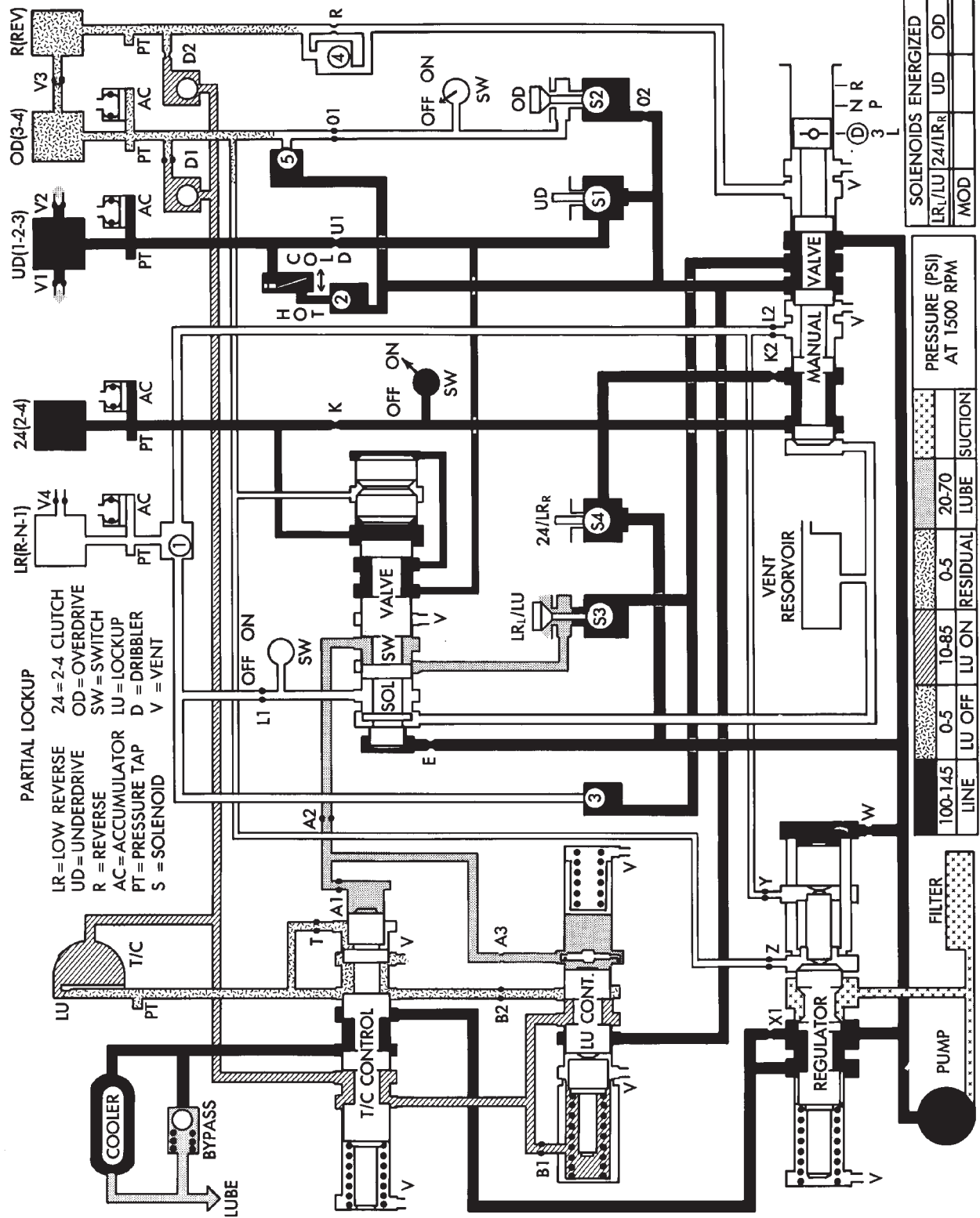

PRESSURE (PSI) AT 1500 RPM		SOLENOIDS ENERGIZED	
LINE	SUCTION	LR/LU	24/LR
100-145	0-5		
0-5	10-85		
LU OFF	LU ON	RESIDUAL	LUBE
20-70			
		UD	OD
		MOD	

9221-84

4 SPEED ELECTRONIC TRANSAXLE HYDRAULIC SCHEMATIC

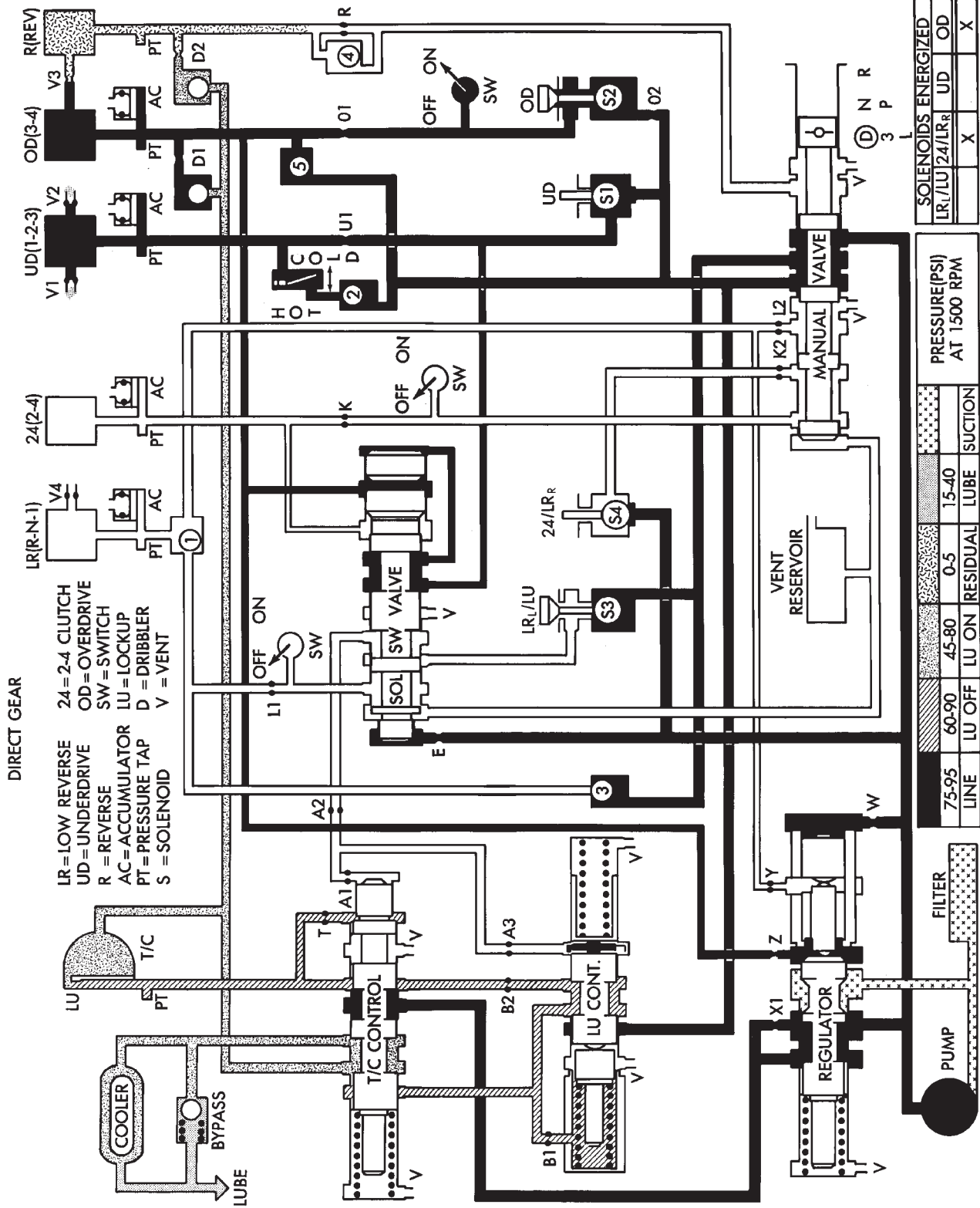

9221-85

4 SPEED ELECTRONIC TRANSAXLE HYDRAULIC SCHEMATIC



DIRECT GEAR
PARTIAL LOCKUP

LR = LOW REVERSE
UD = UNDERDRIVE
R = REVERSE
AC = ACCUMULATOR
PT = PRESSURE TAP
S = SOLENOID

24 = 2-4 CLUTCH
OD = OVERDRIVE
SW = SWITCH
LU = LOCKUP
D = DRIBBLER
V = VENT

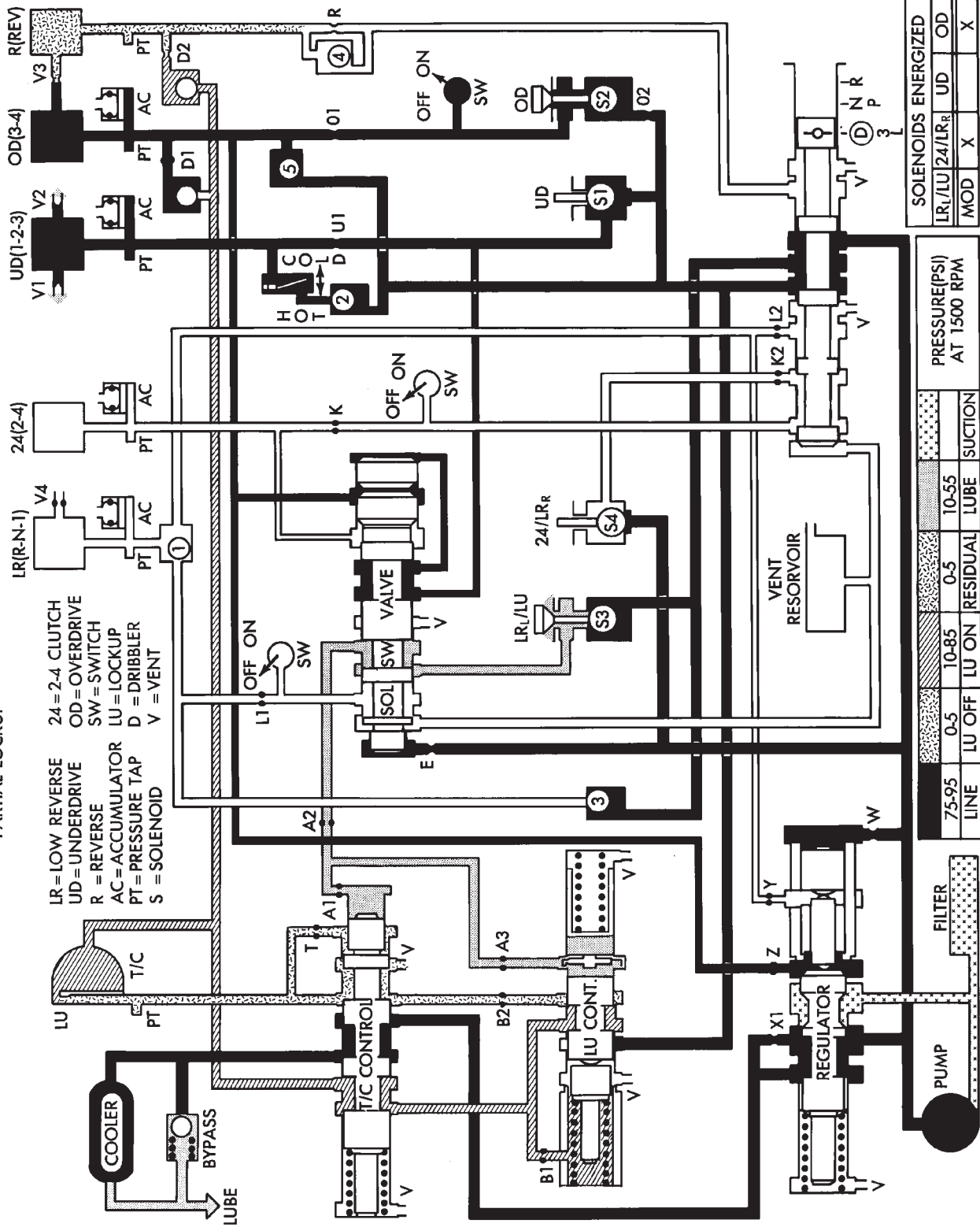

SOLENOIDS ENERGIZED	
LR, LU, 24/LR, UD	OD
MOD	X

PRESSURE (PSI) AT 1500 RPM	
0-5	10-55
LU OFF	LU ON
RESIDUAL	LUBE
SUCTION	

LINE	75-95	0-5	10-85	0-5	10-55	SUCTION
	LU OFF	LU ON	RESIDUAL	LUBE		

9221-86

4 SPEED ELECTRONIC TRANSAXLE HYDRAULIC SCHEMATIC

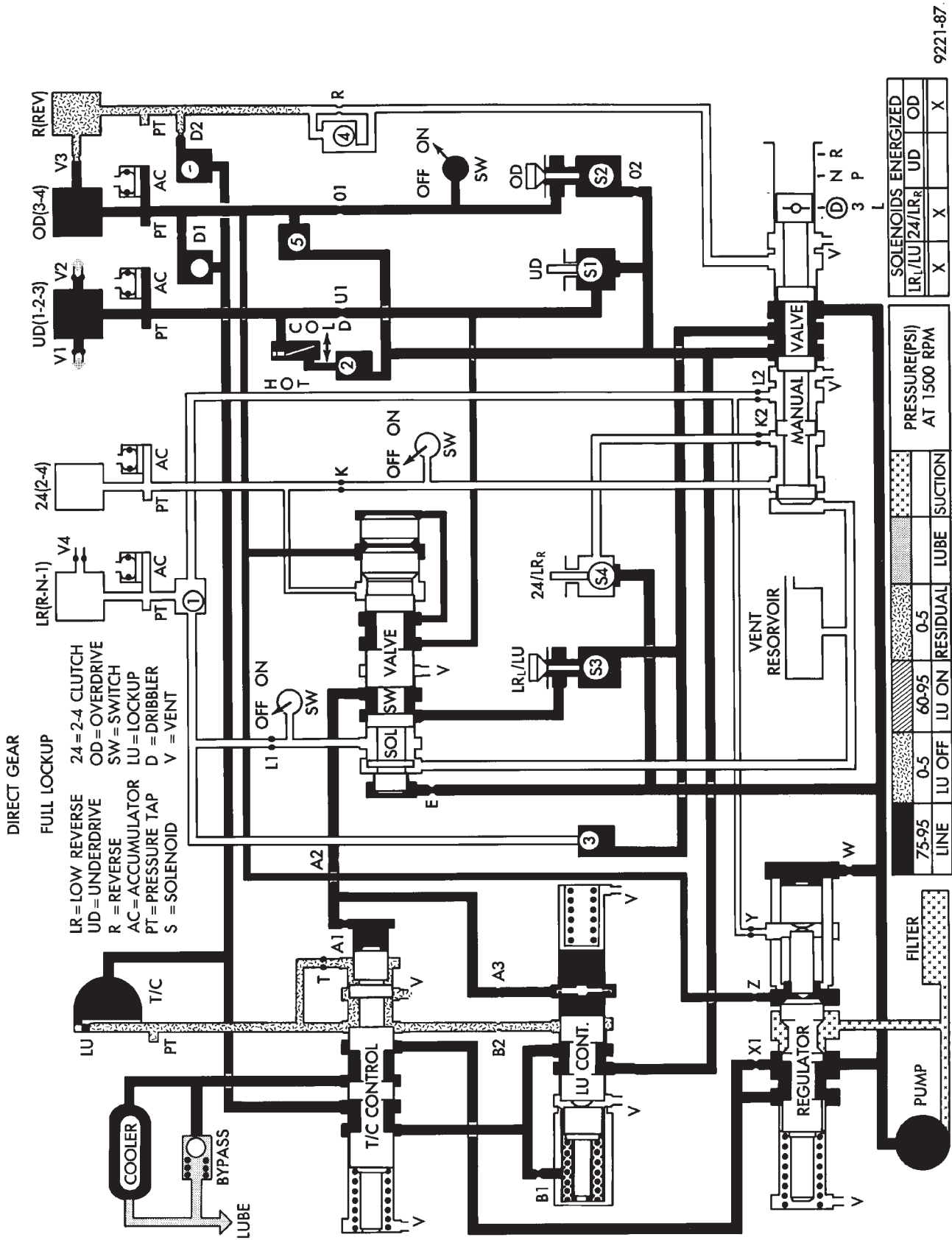

4 SPEED ELECTRONIC TRANSAXLE HYDRAULIC SCHEMATIC

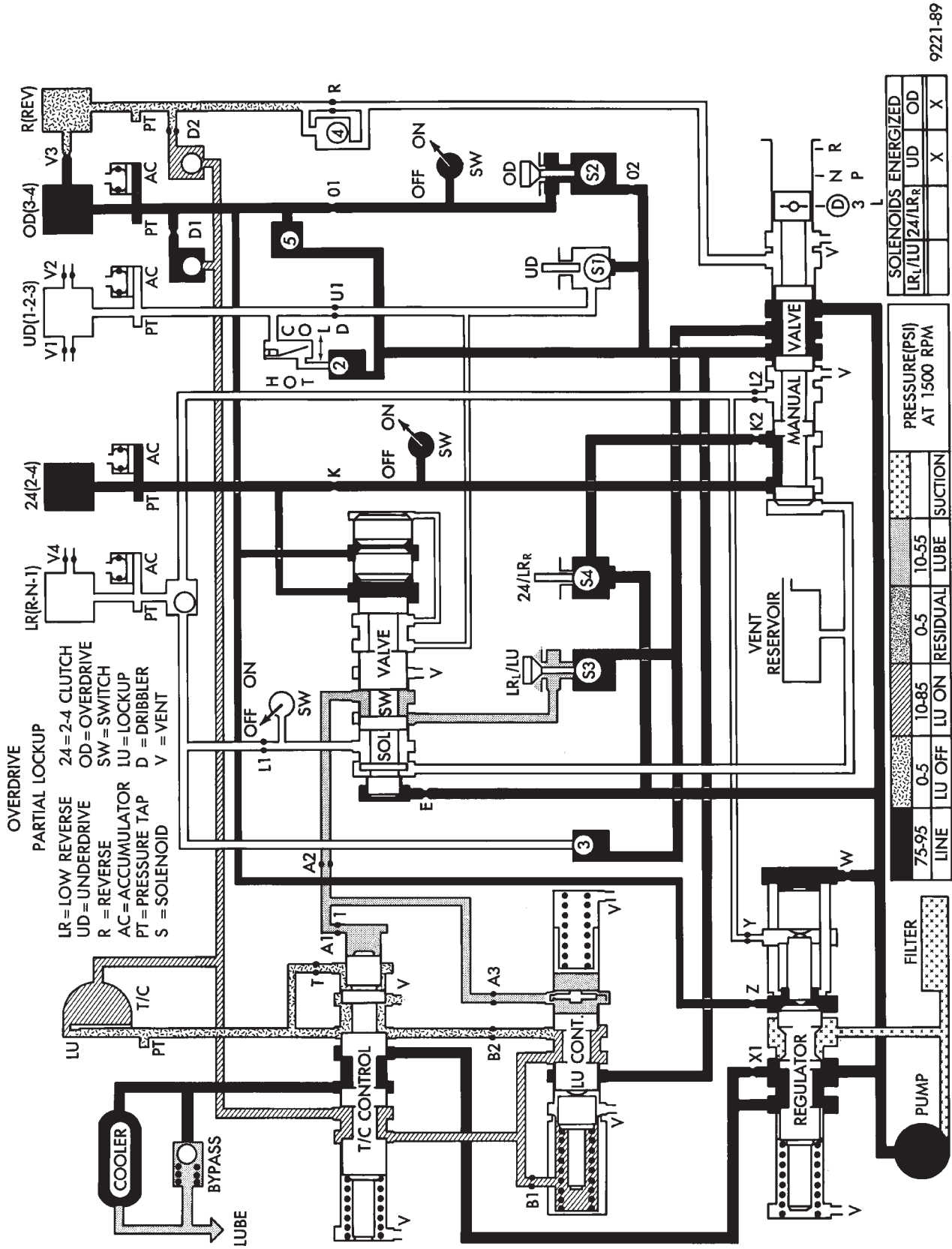

4 SPEED ELECTRONIC TRANSAXLE HYDRAULIC SCHEMATIC

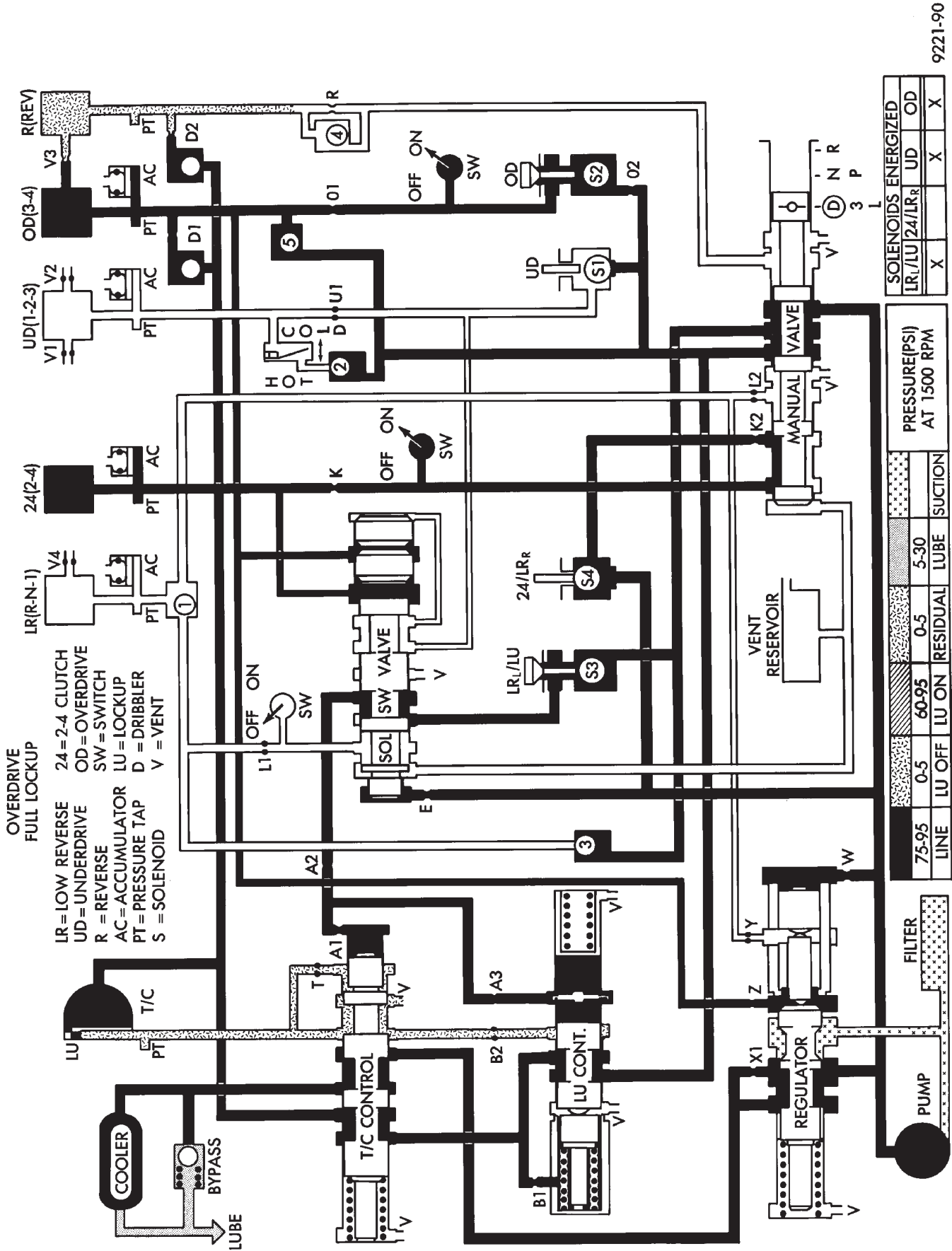

OVERDRIVE FULL LOCKUP
 LR = LOW REVERSE
 UD = UNDERDRIVE
 R = REVERSE
 AC = ACCUMULATOR
 PT = PRESSURE TAP
 S = SOLENOID
 24 = 2-4 CLUTCH
 OD = OVERDRIVE
 SW = SWITCH
 LU = LOCKUP
 D = DRIBBLER
 V = VENT

SOLENOIDS ENERGIZED			
LR/LU	24/LR	UD	OD
X		X	X

PRESSURE (PSI) AT 1500 RPM			
LINE	LU OFF	LU ON	SUCTION
75-95	0-5	60-95	0-5
	0-5	5-30	5-30

SOLENOIDS ENERGIZED			
LR/LU	24/LR	UD	OD
X		X	X

9221-90

4 SPEED ELECTRONIC TRANSAXLE HYDRAULIC SCHEMATIC

4-SPEED ELECTRONIC AUTOMATIC TRANSAXLE

Type	Fully-adaptive, electronically-controlled, four-speed automatic with torque converter and integral differential	
Torque Converter Diameter	241 millimeters (9.48 inches)	
Oil Capacity—Transaxle and Torque Converter	8.6 Liters (18.25 pints)	
Oil Type	MOPAR ATF Type 7176 (or DEXRON II)	
Cooling Method	Water heat exchanger and/or air-to-oil heat exchanger	
Lubrication	Pump (internal-external gear type)	
Gear Ratios:		
Transmission portion:		
First	2.84	
Second	1.57	
Direct	1.00	
Overdrive69	
Rreverse	2.21	
Overall Top Gear Ratio:		
(in overdrive)	2.36	
Pump Clearances:		
Outer Gear to Pocket	Millimeter .045-.141	Inch .0018-.0056
Outer Gear Side Clearance ..	.020-.046	.0008-.0018
Inner Gear Side Clearance ..	.020-.046	.0008-.0018
Tapered Roller Bearing Settings:		
Output Gear	Millimeter .02-.05 Preload	Inch .0008-.002 Preload
Transfer Shaft05-.10 End Play	.002-.004 End Play
Differential15-.29 Preload	.006-.012 Preload
Clutch Clearances:		
Underdrive Clutch	Millimeter .091 to 1.47	Inch .036 to .058
Overdrive Clutch	1.07 to 2.44	.042 to .096
Reverse Clutch	0.76 to 1.24	.030 to .049
2/4 Clutch	0.76 to 2.64	.030 to .104
Low/Reverse Clutch	1.04 to 1.65	.042 to .065

THREE SPEED TRANSAXLE TIGHTENING REFERENCE

Item	Thread Size	Torque		
		Newton-meters	Inch-Pounds	Foot-Pounds
Three Speed Automatic Transaxle:				
Bolt—Bell Housing Cover	9.8-M6-1-10	12	105	—
Bolt—Flex Plate to Crank	M10×1.5×18	95	—	70
Bolt—Flex Plate to Torque Converter	10.9-M10×1.5×13.2	74	—	55
Screw Assy. Transaxle to Cyl. Block	9.8A-M12-1.75-65	95	—	70
Screw Assy. Lower Bell Housing Cover	9.8-M6-1-10	12	105	—
Screw Assy. Manual Control Lever	9.8A-M6-1-35	12	105	—
Screw Assy. Speedometer to Extension	9.8A-M6-1-14	7	60	—
Connector, Cooler Hose to Radiator	1/8-27 NPTF	12	110	—
Bolt—Starter to Transaxle Bell Housing	M10-1.5-30	54	—	40
Bolt—Throttle Cable to Transaxle Case	M6-1.0-14	12	105	—
Bolt—Throttle Lever to Transaxle Shaft	M6-1-25	12	105	—
Bolt—Manual Cable to Transaxle Case	M8-1.75-30	28	250	—
Bolt—Front Motor Mount	M10	54	—	40
Bolt—Left Motor Mount	M10-1.5-25	54	—	40
Dress Up:				
Connector Assembly, Cooler Line	M12-1.75-122	28	250	—
Plug, Pressure Check	1/16-27 NPTF	5	45	—
Switch, Neutral Safety	3/4-16UNF	34	—	25
Differential Area:				
Ring Gear Screw	12.9-M10-1.5-25	95	—	70
Bolt, Extension to Case	9.8-M8-1.25-28	28	250	—
Bolt, Differential Bearing Retainer to Case	9.8-M8-1.25-28	28	250	—
Screw Assy. Differential Cover to Case	9.8-M8-1.25-16	19	165	—
Transfer & Output Shaft Areas:				
Nut, Output Shaft	M20-1.5	271	—	200
Nut, Transfer Shaft	M20-1.5	271	—	200
Bolt, Gov to Support	9.8-M5-0.8-20	7	60	—
Bolt, Gov to Support	9.8-M5-0.8-30	7	60	—
Screw Assy., Governor Counterweight	M8-1.25-35	28	250	—
Screw Assy., Rear Cover to Case	9.8-M8-1.25-16	19	165	—
Plug, Reverse Band Shaft	1/4-18-NPTF	7	60	—
Pump & Kickdown Band Areas:				
Bolt, Reaction Shaft Assembly	9.8-M8-1.25-19	28	250	—
Bolt Assy., Pump to Case	10.9-M8-1.25-25	31	275	—
Nut, Kickdown Band Adjustment Lock	M12-1.75	47	—	35
Valve Body & Sprag Areas:				
Bolt, Sprag Retainer to Transfer Case	9.8-M8-1.25-23	28	250	—
Screw Assy., Valve Body	9.8A-M5-0.8-11	5	40	—
Screw Assy., Transfer Plate	9.8A-M5-0.8-25	5	40	—
Screw Assy., Filter	9.8A-M5-0.8-30	5	40	—
Screw, Transfer Plate to Case	9.8-M6-1-30	12	105	—
Screw Assy., Oil Pan to Case	9.8-M8-1.25-16	19	165	—
Nut, Reverse Band Adjusting Lock	M8-1.25	14	120	—

9121-11

SPECIFICATIONS

4 SPEED ELECTRONIC TRANSAXLE TIGHTENING REFERENCE

Item	Thread Size	Torque		
		Newton-Meters	Inch-Pounds	Foot-Pounds
Electronic Automatic Transaxle:				
Cooler Line Fittings	1/8 × 27 NPT	12	110	—
Differential Cover	M8 × 1.25	19	165	—
Differential Ring Gear	M10 × 1.0 × 25	95	—	70
Differential Bearing Retainer	M8 × 1.25 × 23	28	—	21
Rear End Cover	M8 × 1.25	19	—	14
Extension Housing	M8 × 1.25 × 33	28	—	21
Input Speed Sensor	M22 × 1.5	27	—	20
L/R Clutch Retainer	M5 × 0.8	5	40	—
Neutral Safety Switch	3/4 IN. × 16	34	—	25
Oil Pan to Case	M8 × 1.25	19	—	14
Output Gear Bolt (1.5 inch hex)	M18 × 1.75	271	—	200
Output Speed Sensor	M24 × 2	27	—	20
Pressure Taps	1/16—27 NPTF	5	45	—
PRNDL Switch	M22 × 2.5	34	—	25
Pump to Case	M8 × 1.25	22	—	23
Reaction Shaft to Pump	M8 × 1.25	22	—	23
Solenoid Assy. to Case	M6 × 1.0 × 93.5	12	105	—
Transfer Plate to Case	M6 × 1.0	12	105	—
Transfer Gear Nut (1.25 inch hex)	M22 × 1.5	271	—	200
Valve Body & Transfer Plate	M5 × 0.8	5	40	—
Vent Assembly	1/8 PIPE	12	110	—
8-Way Solenoid Connector	M6 × 1.0	4	38	—
60-Way EATX Connector	M6 × 1.0	4	38	—

9121-12

POWER TRANSFER UNIT TIGHTENING REFERENCE

APPLICATION	THREAD SIZE	NEWTON-METERS	INCH POUNDS	FOOT POUNDS
Flange Nut	M16 × 1.5	162	—	120
End Cover	M8 × 1.25	28	250	—
Rear Cover	M8 × 1.25	28	250	—
Ring Gear	M10 × 1.0	94	—	70
Fill Plug	1/2 × 20	27	240	—
Inspection Plug	M50 × 1.5	20	180	—

9121-72



<CONVERSION CHART

INCHES TO MILLIMETERS

All values in this table are exact

inches	0.000	0.001	0.002	0.003	0.004	0.005	0.006	0.007	0.008	0.009
	millimeters									
0.000	—	0.0254	0.0508	0.0762	0.1016	0.1270	0.1524	0.1778	0.2032	0.2286
0.010	0.2540	0.2794	0.3048	0.3302	0.3556	0.3810	0.4064	0.4318	0.4572	0.4826
0.020	0.5080	0.5334	0.5588	0.5842	0.6096	0.6350	0.6604	0.6858	0.7112	0.7366
0.030	0.7620	0.7874	0.8128	0.8382	0.8636	0.8890	0.9144	0.9398	0.9652	0.9906
0.040	1.0160	1.0414	1.0668	1.0922	1.1176	1.1430	1.1684	1.1938	1.2192	1.2446
0.050	1.2700	1.2954	1.3208	1.3462	1.3716	1.3970	1.4224	1.4478	1.4732	1.4986
0.060	1.5240	1.5494	1.5748	1.6002	1.6256	1.6510	1.6764	1.7018	1.7272	1.7526
0.070	1.7780	1.8034	1.8288	1.8542	1.8796	1.9050	1.9304	1.9558	1.9812	2.0066
0.080	2.0320	2.0574	2.0828	2.1082	2.1336	2.1590	2.1844	2.2098	2.2352	2.2606
0.090	2.2860	2.3114	2.3368	2.3622	2.3876	2.4130	2.4384	2.4638	2.4892	2.5146
0.100	2.5400	2.5654	2.5908	2.6162	2.6416	2.6670	2.6924	2.7178	2.7432	2.7686
0.110	2.7940	2.8194	2.8448	2.8702	2.8956	2.9210	2.9464	2.9718	2.9972	3.0226
0.120	3.0480	3.0734	3.0988	3.1242	3.1496	3.1750	3.2004	3.2258	3.2512	3.2766
0.130	3.3020	3.3274	3.3528	3.3782	3.4036	3.4290	3.4544	3.4798	3.5052	3.5306
0.140	3.5560	3.5814	3.6068	3.6322	3.6576	3.6830	3.7084	3.7338	3.7592	3.7846
0.150	3.8100	3.8354	3.8608	3.8862	3.9116	3.9370	3.9624	3.9878	4.0132	4.0386
0.160	4.0640	4.0894	4.1148	4.1402	4.1656	4.1910	4.2164	4.2418	4.2672	4.2926
0.170	4.3180	4.3434	4.3688	4.3942	4.4196	4.4450	4.4704	4.4958	4.5212	4.5466
0.180	4.5720	4.5974	4.6228	4.6482	4.6736	4.6990	4.7244	4.7498	4.7752	4.8006
0.190	4.8260	4.8514	4.8768	4.9022	4.9276	4.9530	4.9784	5.0038	5.0292	5.0546
0.200	5.0800	5.1054	5.1308	5.1562	5.1816	5.2070	5.2324	5.2578	5.2832	5.3086
0.210	5.3340	5.3594	5.3848	5.4102	5.4356	5.4610	5.4864	5.5118	5.5372	5.5626
0.220	5.5880	5.6134	5.6388	5.6642	5.6896	5.7150	5.7404	5.7658	5.7912	5.8166
0.230	5.8420	5.8674	5.8928	5.9182	5.9436	5.9690	5.9944	6.0198	6.0452	6.0706
0.240	6.0960	6.1214	6.1468	6.1722	6.1976	6.2230	6.2484	6.2738	6.2992	6.3246
0.250	6.3500	6.3754	6.4008	6.4262	6.4516	6.4770	6.5024	6.5278	6.5532	6.5786
0.260	6.6040	6.6294	6.6548	6.6802	6.7056	6.7310	6.7564	6.7818	6.8072	6.8326
0.270	6.8580	6.8834	6.9088	6.9342	6.9596	6.9850	7.0104	7.0358	7.0612	7.0866
0.280	7.1120	7.1374	7.1628	7.1882	7.2136	7.2390	7.2644	7.2898	7.3152	7.3406
0.290	7.3660	7.3914	7.4168	7.4422	7.4676	7.4930	7.5184	7.5438	7.5692	7.5946
0.300	7.6200	7.6454	7.6708	7.6962	7.7216	7.7470	7.7724	7.7978	7.8232	7.8486
0.310	7.8740	7.8994	7.9248	7.9502	7.9756	8.0010	8.0264	8.0518	8.0772	8.1026
0.320	8.1280	8.1534	8.1788	8.2042	8.2296	8.2550	8.2804	8.3058	8.3312	8.3566
0.330	8.3820	8.4074	8.4328	8.4582	8.4836	8.5090	8.5344	8.5598	8.5852	8.6106
0.340	8.6360	8.6614	8.6868	8.7122	8.7376	8.7630	8.7884	8.8138	8.8392	8.8646
0.350	8.8900	8.9154	8.9408	8.9662	8.9916	9.0170	9.0424	9.0678	9.0932	9.1186
0.360	9.1440	9.1694	9.1948	9.2202	9.2456	9.2710	9.2964	9.3218	9.3472	9.3726
0.370	9.3980	9.4234	9.4488	9.4742	9.4996	9.5250	9.5504	9.5758	9.6012	9.6266
0.380	9.6520	9.6774	9.7028	9.7282	9.7586	9.7790	9.8044	9.8298	9.8552	9.8806
0.390	9.9060	9.9314	9.9568	9.9822	10.0076	10.0330	10.0584	10.0838	10.1092	10.1346
0.400	10.1600	10.1854	10.2108	10.2362	10.2616	10.2870	10.3124	10.3378	10.3632	10.3886
0.410	10.4140	10.4394	10.4648	10.4902	10.5156	10.5410	10.5664	10.5918	10.6172	10.6426
0.420	10.6680	10.6934	10.7188	10.7442	10.7696	10.7950	10.8204	10.8458	10.8712	10.8966
0.430	10.9220	10.9474	10.9728	10.9982	11.0236	11.0490	11.0744	11.0998	11.1252	11.1506
0.440	11.1760	11.2014	11.2268	11.2522	11.2776	11.3030	11.3284	11.3538	11.3792	11.4046
0.450	11.4300	11.4554	11.4808	11.5062	11.5316	11.5570	11.5824	11.6078	11.6332	11.6586
0.460	11.6840	11.7094	11.7348	11.7602	11.7856	11.8110	11.8364	11.8618	11.8872	11.9126
0.470	11.9380	11.9634	11.9888	12.0142	12.0396	12.0650	12.0904	12.1158	12.1412	12.1666
0.480	12.1920	12.2174	12.2428	12.2682	12.2936	12.3190	12.3444	12.3698	12.3952	12.4206
0.490	12.4460	12.4714	12.4968	12.5222	12.5476	12.5730	12.5984	12.6238	12.6492	12.6746
inches	0.000	0.001	0.002	0.003	0.004	0.005	0.006	0.007	0.008	0.009

