

MANUAL TRANSAXLE CLUTCH

CONTENTS

	page		page
CLEANING PRECAUTIONS	9	CLUTCH/STARTER INTERLOCK SWITCH	7
CLUTCH DISC REPLACEMENT	8	EXCESSIVE CLUTCH SPIN TIME/CLASH	
CLUTCH CABLE REPLACEMENT	5	INTO REVERSE COMPLAINTS	1
CLUTCH CABLE MECHANISM	1	GENERAL INFORMATION	1
CLUTCH CHATTER COMPLAINTS	1	RELEASE BEARING AND FORK	9

GENERAL INFORMATION

Throughout this group, references may be made to a particular vehicle by letter or number designation. A chart showing the breakdown of these designations is included in the Introduction Section at the front of this service manual.

The clutch used in all models is a single, dry disc type with automatic adjustment for wear being provided in the clutch pedal.

The clutch pedal is connected to the torque shaft through a cable and lever.

The upper end of the clutch pedal pivots in the pedal bracket on two nylon bushings. These bushings do not require periodic lubrication.

CLUTCH CHATTER COMPLAINTS

For all clutch chatter complaints, do the following:

- (1) Check for loose, misaligned, or broken engine and transmission mounts. If present, they should be corrected at this time. Test vehicle for chatter. If chatter is gone, there is no need to go any further. If chatter persists:
- (2) Check to see if clutch cable routing is correct and operates smoothly.
- (3) Check for loose connections in drive train. Correct any problems and determine if clutch chatter complaint has been satisfied. If not,
- (4) Remove transaxle. See Group 21, Manual Transaxle, for procedure.
- (5) Check to see if the release bearing is sticky or binding. Replace bearing, if needed.
- (6) Check linkage for excessive wear on bushings. Replace all worn parts.
- (7) Check flywheel and clutch pressure plate for contamination (dirt, oil) or scored. Replace flywheel and/or pressure plate, if required.
- (8) Check to see if the clutch disc hub splines are damaged. Replace with new disc.
- (9) Check input shaft on the transaxle for damaged splines. Replace if necessary.
- (10) Check for uneven wear on clutch fingers.

EXCESSIVE CLUTCH SPIN TIME/CLASH INTO REVERSE COMPLAINTS

For all excessive clutch spin time/clash into reverse complaints, do the following:

- (1) Depress clutch pedal to floor and hold. After three seconds, shift to reverse. If clash is present, clutch has excessive spin time.
- (2) Remove transaxle. See Group 21, Manual Transaxle, for procedure.
- (3) Check the input shaft spline, clutch disc spline and release bearing for dry rust. If dry rust is present, clean rust off. Apply a light coat of bearing grease to the input shaft spline, where the clutch disc slides.
- (4) Check to see if the clutch disc hub splines are damaged. If damaged replace with new disc.
- (5) Check input shaft spline of the transaxle for damage. Replace input shaft if required.
- (6) Install clutch assembly and transaxle.

CLUTCH CABLE MECHANISM

The manual transaxle clutch release system has a unique self-adjusting mechanism to compensate for clutch disc wear. This adjuster mechanism is located within the clutch pedal. The preload spring maintains tension on the cable. This tension keeps the clutch release bearing continuously loaded against the fingers of the clutch cover assembly.

When the pedal is depressed, teeth on the adjuster and the positioner engage and pull the release cable. A spring located behind the adjuster ensures proper tooth engagement.

When the pedal is released, the adjuster contacts the bumper. This separates the adjuster and positioner teeth, allowing the preload spring to function.

SERVICE DIAGNOSIS—CLUTCH SLIPS

CONDITION FOUND	CAUSE	CORRECTION
1. Disc facing worn out.	a) Normal wear. b) Driver frequently "rides" (slips) clutch. Results in rapid wear overheating. c) Insufficient clutch cover diaphragm spring tension.	Replace clutch disc. Also replace cover if spring is weak or pressure plate surface is damaged.
2. Clutch disc facing contaminated with oil or grease.	a) Leak at rear main seal or at transmission input shaft seal. b) Excessive amount of grease applied to input shaft splines. c) Road splash, water entering housing.	a), b), c), d) Replace leaking seals. Apply less grease to input shaft splines. Replace clutch disc (do not clean and reuse) and clutch cover.
3. Clutch is running partially disengaged.	Release bearing sticking-binding. Does not return to normal running position.	Verify that bearing is actually binding, then replace bearing and transmission front bearing retainer if sleeve surface is damaged.
4. Flywheel height incorrect.	Flywheel surface improperly machined. Too much stock removed or surface is excessively tapered.	Replace flywheel.
5. Wrong disc or pressure plate installed.	Incorrect parts order or model number.	Replace with correct parts. Compare old and new parts before installation.
6. Clutch disc, cover and/or diaphragm spring, warped, distorted.	a) Rough handling (impact) bent cover, spring, or disc. b) Incorrect bolt tightening sequence and method caused warped cover.	Install new disc or cover as needed. Follow installation/tightening instructions.
7. Facing on flywheel side of disc torn, gouged, worn.	Flywheel surface scored and nicked.	Reduce scores and nicks by sanding or surface grinding. Replace flywheel if scores-nicks are deeper than .002-.004 inch.
8. Clutch disc facing burnt (charred). Flywheel and cover pressure plate surfaces heavily glazed.	a) Frequent operation under high loads or hard acceleration conditions. b) Driver frequently "rides" (slips) clutch. Results in rapid wear and overheating of disc and cover.	Scuff sand flywheel. Replace clutch cover and disc. Alert driver to problem cause.
9. One or both clutch disc facings have fractured into small pieces.	a) Driver performs a 5-1 downshift at vehicle speed in excess of 60 mph. b) Leak of rear main seal or transaxle input shaft seal. c) Excessive heat from slippage.	Alert driver to problem cause. Replace clutch cover and disc. Make sure flywheel surface is not damaged. If so, replace.

SERVICE DIAGNOSIS—IMPROPER CLUTCH RELEASE

CONDITION FOUND	CAUSE	CORRECTION
1. Clutch disc warped.	New disc not checked for axial runout before installation.	Replace disc.
2. Clutch disc binds on input shaft splines.	<ul style="list-style-type: none"> a) Clutch disc hub splines damaged during installation. b) Input shaft splines rough, damaged. c) Corrosion; rust formations on splines of disc and input shaft. 	Clean, smooth and lubricate disc and shaft spines. Replace disc and/or input shaft if splines are severely damaged.
3. Clutch disc rusted to flywheel and/or pressure plate.	Occurs in vehicles stored, or not driven for extended periods of time. Also occurs after steam cleaning if vehicle is not used for extended periods.	Remove clutch cover and disc. Sand rusted surfaces clean with 180 grit paper. Replace disc cover, and flywheel if corrosion is severe.
4. Clutch disc too thick.	Wrong disc installed.	Replace disc.
5. Clutch will not disengage properly.	<ul style="list-style-type: none"> a) Clutch cover loose. b) Wrong clutch disc. c) Disc bent, distorted during installation. d) Clutch cover diaphragm spring bent or warped during transmission installation. e) Clutch disc installed backwards. f) Release fork bent loose or damaged. g) Clutch cable binding or routed incorrectly. h) Self adjuster in pedal not functioning properly. 	<ul style="list-style-type: none"> a) Tighten bolts. b) Install correct disc. c) Replace disc. d) Replace cover. e) Remove and reinstall disc correctly. Be sure disc side marked "Flywheel side" is actually toward flywheel. f) Replace fork if worn or damaged. g) Check cable routing. h) Pull pedal upward to disengage cable adjuster.

SERVICE DIAGNOSIS—CLUTCH NOISE

CONDITION FOUND	CAUSE	CORRECTION
1. Clutch components damaged or worn out prematurely.	Incorrect or sub-standard clutch parts.	Replace with parts of correct type and quality.
2. Release shaft bushings in transaxle binding or seized.	a) Dirt or contamination. b) Corrosion.	a, b) Wipe shaft, replace or lube bushings.
3. Loose components.	Attaching bolts loose at flywheel, cover, or clutch housing.	Tighten bolts to specific torque. Replace any clutch bolts that are damaged.
4. Contact surface of release bearing damaged.	a) Clutch cover incorrect, or release fingers are bent or distorted causing damage. b) Release bearing defect.	a) Replace clutch cover and bearing. b) Replace bearing.
5. Release bearing is noisy.	Release bearing defect.	Replace bearing.
6. Clutch pedal squeak.	a) Pedal bushings worn out or cracked. b) Inadequate lubrication.	a) Replace bushings if worn or damaged. b) Lubricate bushings, adjuster and positioner.

SERVICE DIAGNOSIS—CLUTCH GRAB/CHATTER

CONDITION FOUND	CAUSE	CORRECTION
1. Clutch disc facing covered with oil or grease.	a) Oil leak at engine rear main or transaxle input shaft seal. b) Too much grease applied to splines or disc and input shaft.	a) Correct leak and replace disc (do not clean and reuse the disc). Clean flywheel and clutch pressure plate. b) Apply lighter grease coating to splines and replace disc (do not clean and reuse the disc).
2. Clutch disc and/or cover warped, or disc facings exhibit unusual wear or appear to be wrong type.	Incorrect or substandard parts.	Replace disc and/or cover with correct parts.
3. No fault found with clutch components.	a) Problem actually related to suspension or driveline component. b) Engine related problems.	a) Further diagnosis required. Check engine/transmission mounts, suspension attaching parts and other driveline components as needed. b) Check EFI and ignition systems.
4. Partial engagement of clutch disc (one side worn-opposite side glazed and lightly worn).	a) Clutch cover, spring, or release fingers bent, distorted (rough handling, improper assembly). b) Clutch disc damaged or distorted. c) Clutch misalignment.	a) Replace clutch cover and disc. b) Replace disc. c) Check alignment and runout of flywheel, disc, or cover and/or clutch housing. Correct as necessary.

9206-8

CLUTCH CABLE REPLACEMENT

(1) Remove retainer from clutch release lever at transaxle by pulling on the tail of the ball stud (Fig. 1).

(2) Pry out ball end of cable from positioner adjuster and remove cable, passing it through the hoop in the shock tower mounting bracket.

(3) Inspect cable for wear and contamination. The inner cable strand should move smoothly inside the cable housing. If cable is worn or damaged, replace the cable. **Do not lubricate.**

(4) Inspect the clutch pedal and adjuster mechanism for wear. Apply a multipurpose lubricant on parts indicated (Fig. 1).

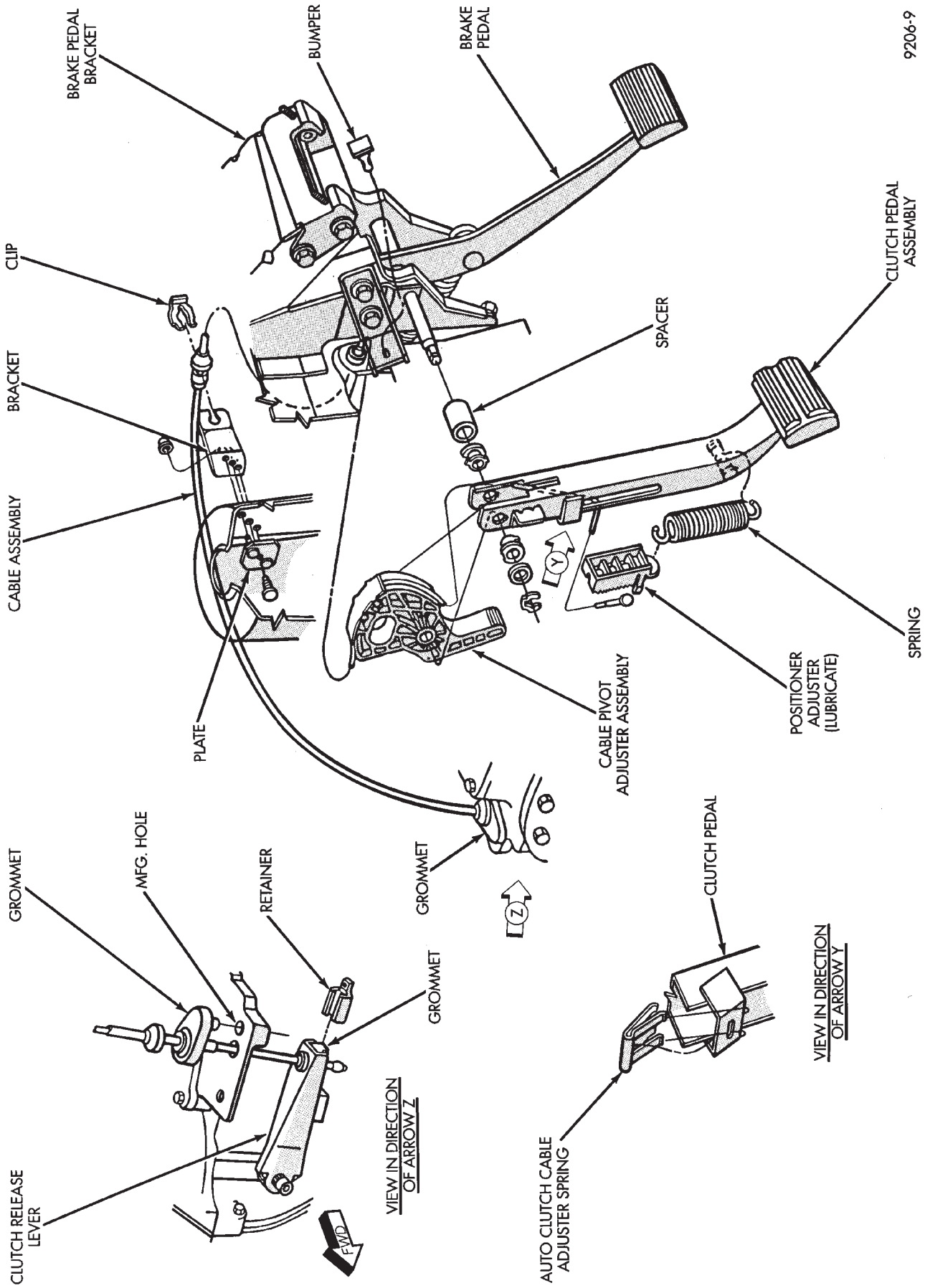

9206-9

Fig. 1 Self-Adjusting Clutch Release Mechanism

(5) To install, reverse procedure of steps (3) through (1).

(6) After installation, push and lift the clutch pedal 2 or 3 times to allow adjuster mechanism to function.

(7) Check clutch pedal starter interlock switch operation.

CLUTCH/STARTER INTERLOCK SWITCH

The clutch/starter interlock switch functions as a safety interlock device. It prevents possible engine cranking with the manual transmission in gear.

The clutch switch is wired in series between the starter relay coil and the ignition switch.

The clutch/starter interlock switch is mounted to a bracket located next to the clutch pedal. The switch is held in place by two plastic wing tabs.

The clutch/starter interlock switch has an adjustable striker plate. The striker plate is located on the left side of the clutch pedal (Fig. 2).

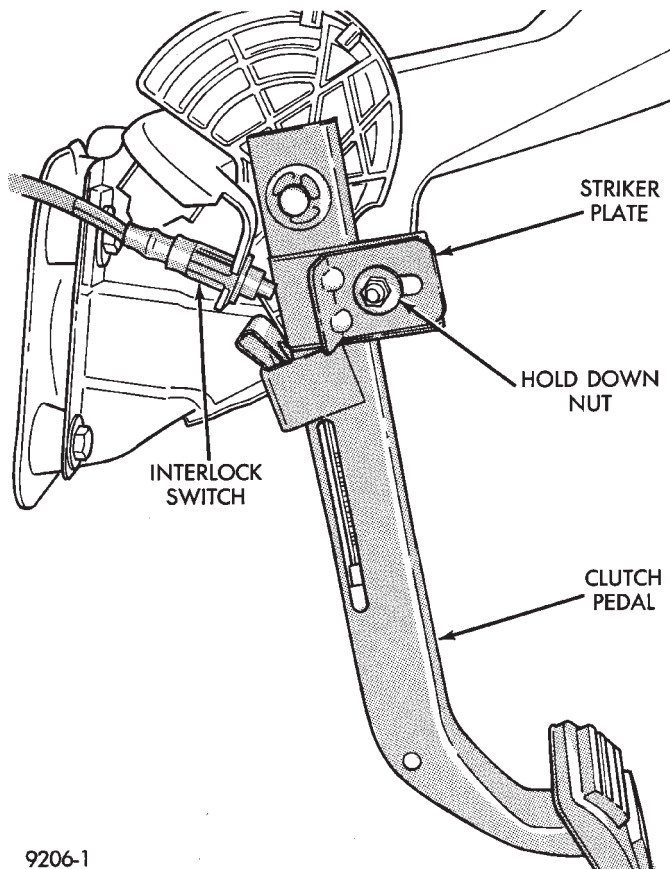

9206-1

Fig. 2 Clutch Interlock Switch and Components

DIAGNOSIS

Disconnect clutch/starter interlock switch harness from instrument panel wiring harness. Using an ohm meter, check for continuity between the two terminals in the connector on the switch harness. There should be no continuity between the terminals when the switch is in its neutral (fully extended) position. When

the switch is depressed more than 1 mm (0.040) the ohm meter should show continuity at the switch harness.

If all ohm meter readings are correct and the switch does not operate correctly, adjustment is required. Refer to Switch Adjustment Procedure to adjust switch.

REMOVAL

(1) Disconnect electrical harness to switch connector.

(2) Push switch out of mounting bracket and slide wires through slot in bracket.

INSTALLATION

(1) Slide switch wires through slot in switch bracket.

(2) Line up switch tab with slot in switch bracket and push switch into position. Do not pull on the switch wires to seat switch into bracket, switch damage may occur.

(3) After installation, the switch must be adjusted and checked for proper operation. Refer to Switch Adjustment Procedure.

ADJUSTMENT PROCEDURE

When performing switch adjustment, the floor mat should be removed before beginning adjustment procedures.

(1) Set the park brake.

(2) Disconnect clutch cable at the transaxle end of the cable.

(3) Depress clutch pedal, loosen adjusting nut and slide the striker plate forward to fully compress the interlock switch plunger.

(4) Tighten adjusting nut to 12 N•m (105 in. lbs.).

(5) Reconnect clutch cable.

The interlock switch is now adjusted. A final check is required to insure that the switch is made below the clutch release point.

(1) With the park brake set and the vehicle **IN NEUTRAL** turn the key to the start position. The vehicle should not crank. **If the vehicle cranks do not continue with this test.** Recheck the switch and switch adjustment to determine the cause. If the vehicle does not crank proceed to step 2.

(2) With the park brake set and the vehicle **IN GEAR** turn the key to the start position.

WARNING: BEFORE PERFORMING STEP THREE BE SURE THAT THE AREA IN FRONT OF THE VEHICLE IS CLEAR OF OBSTRUCTIONS AND PEOPLE. VEHICLE MAY MOVE WHEN PERFORMING THIS TEST.

(3) Slowly depress the clutch pedal and feel for any vehicle motion when the starter is energized. If there is no motion the switch is properly adjusted. If motion is felt, repeat the adjustment procedure.

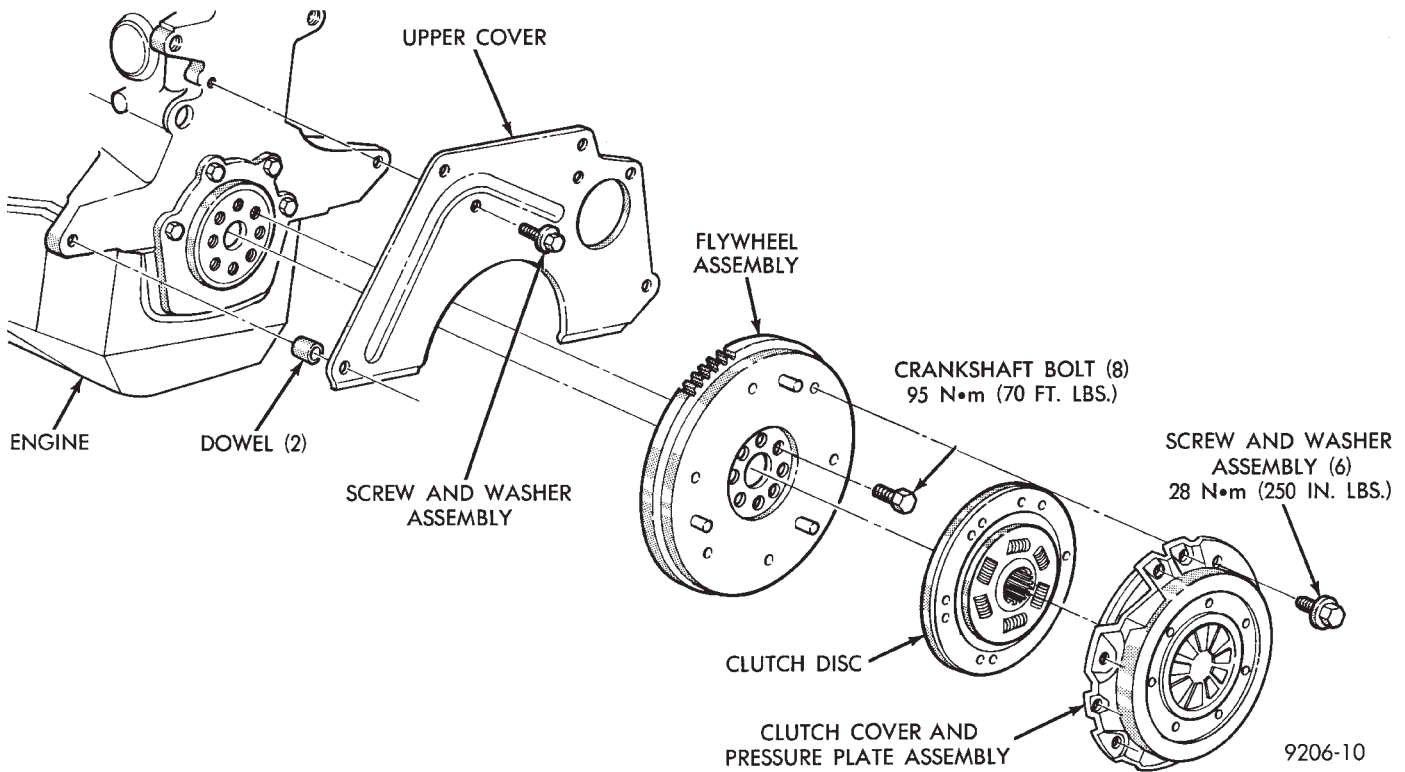

Fig. 3 Manual Transaxle Clutch

CLUTCH DISC REPLACEMENT

REMOVAL

(1) Remove transaxle. See Group 21, Manual Transaxle, for procedure.

(2) Mark clutch cover and flywheel, to maintain their same relative positions when installing clutch assembly (Fig. 3).

(3) Insert Clutch Disc Aligning Tool C-4676 through the clutch disc hub to prevent the clutch disc from falling and damaging the facings (Fig. 4).

(4) Loosen clutch cover attaching bolts, one or two turns at a time, in a crisscross pattern, to release spring pressure evenly and avoid cover damage.

(5) Remove the clutch pressure plate and cover assembly and disc from flywheel. Handle carefully to avoid contaminating the friction surfaces.

CAUTION: Avoid touching disc face with oily hands. Clutch chatter may result.

INSPECTION

(1) Inspect for oil leakage through engine rear main bearing oil seal and transaxle drive pinion seal. If leakage is noted, it should be corrected at this time.

(2) The friction faces of the flywheel and pressure plate should not have excessive discoloration, burned areas, small cracks, deep grooves, or ridges. Replace parts as required.

(3) Clean the flywheel face with crocus cloth or fine sandpaper (400-600 grade), then wipe the surface with

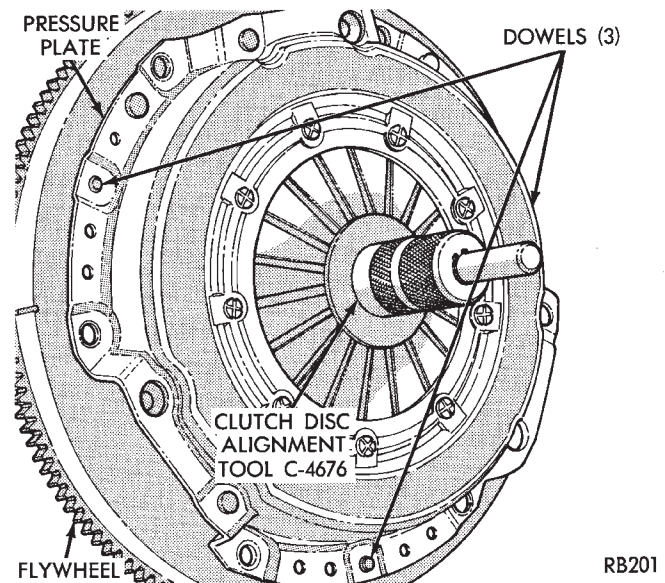

Fig. 4 Clutch Disc Aligning Tool

mineral spirits. If the surface is severely scored, heat checked, or warped, replace the flywheel.

CAUTION: Do not flat-machine the flywheel face. The surface profile is tapered.

(4) The heavy side of the flywheel is indicated by a daub of white paint near the outside diameter. To

minimize the effects of flywheel unbalance, perform the following installation procedure:

- (a) Loosely assemble the flywheel to the crankshaft. Use new flywheel attaching bolts which have sealant on the threads. If new bolts are not available, apply Loctite sealant to the threads of the original bolts. This sealant is required to prevent engine oil leakage.
- (b) Rotate the flywheel and crankshaft until the daub of white paint (heavy side) is at the 12 o'clock position.
- (c) Torque flywheel attaching bolts to 95 N•m (70 ft. lbs.) using a crisscross pattern.
- (5) The disc assembly should be handled without touching the facings. Replace disc if the facings show evidence of grease or oil soakage, or wear to within less than .38 mm (.015 inch) of the rivet heads. The splines on the disc hub and transaxle input shaft should be a snug fit without signs of excessive wear. Metallic portions of disc assembly should be dry and clean, and not been discolored from excessive heat. Each of the arched springs between the facings should not be broken and all rivets should be tight.
- (6) Wipe the friction surface of the pressure plate with mineral spirits.
- (7) Using a straight edge, check pressure plate for flatness. The pressure plate friction area should be flat within .010 inch and free from discoloration, burned areas, cracks, grooves, or ridges.
- (8) Using a surface plate, test cover for flatness. All sections around attaching bolt holes should be in contact with surface plate within .015 inch.
- (9) The cover should be a snug fit on flywheel dowels. If the clutch assembly does not meet these requirements, it should be replaced.

INSTALLATION

- (1) Mount clutch assembly on flywheel, being careful to properly align dowels and the alignment marks made before removal. If new clutch or flywheel is installed, align cover balance spot as close as possible to flywheel balance orange spot. Apply pressure to the alignment tool. Center the tip of the tool into the crankshaft and the sliding cone into the clutch fingers. Tighten the clutch attaching bolts sufficiently to hold the disc in position.
- (2) To avoid distortion of the clutch cover, bolts should be tightened a few turns at a time, in a crisscross pattern, until they are all seated. Tighten bolts to 28 N•m (250 in. lbs.) following a crisscross pattern sequence. Remove clutch disc alignment tool.
- (3) Install transaxle. See Group 21, Manual Transaxle, for procedure.

RELEASE BEARING AND FORK

Remove the transaxle from the vehicle. See Group 21 for removal and installation procedures.

REMOVAL AND INSTALLATION

- (1) Remove clutch release shaft E-clip.
- (2) Remove the clutch release shaft and then slide the fork and bearing assembly off the bearing pilot.
- (3) Remove the fork from the bearing thrust plate.
- (4) Examine the condition of the release bearing. **It is pre-lubricated and sealed and should not be immersed in solvent.**
- (5) The bearing should turn smoothly when held in the hand under a light thrust load. A light drag caused by the lubricant fill is normal. If the bearing is noisy, rough, or dry, replace the complete bearing assembly with a new bearing.
- (6) The bearing has a plastic sleeve pre-lubricated at assembly. Wipe out the old grease. Refill the sleeve cavities and coat the inner surface with multipurpose grease. If the liner is cracked or worn, replace the bearing assembly.
- (7) Check the condition of the spring clips. If the clips are broken or distorted, replace the bearing assembly.
- (8) Before assembling the fork, lubricate the rounded thrust pads and the spring clip cavities with multipurpose grease.
- (9) Assemble the fork to the bearing by sliding the thrust pads under the spring clips. Be careful to avoid distorting the spring clips. **These clips prevent the bearing thrust plate from rotating with the bearing.**
- (10) Slide the bearing and fork assembly onto the input shaft bearing retainer.
- (11) Position the release shaft bushings in the housing and install the release shaft. A small amount of bearing grease between the release shaft bushing and the shaft is often beneficial but not required.
- (12) Install the retainer clip in the shaft groove near the large bushing.
- (13) Install the release lever and retaining clip on the outer end of the release shaft.

CLEANING PRECAUTIONS

Condensation from steam vapors tend to accumulate on the internal clutch mechanism when the vehicle is steam cleaned. The facing of the disc will absorb moisture. The force exerted by the pressure plate will bond the facings to flywheel and/or, pressure plate, if vehicle is allowed to stand for some time before use. If this condition occurs, it will require replacement of disc assembly, flywheel, and/or clutch assembly. After cleaning, drive the vehicle to its normal clutch operating temperature. This will dry off disc assembly, pressure plate, and flywheel.

