

ELECTRICAL

GROUP INDEX

	Page		Page
AUDIO SYSTEMS	8F	POWER MIRRORS	8T
BATTERY/STARTER/ALTERNATOR SERVICE ...	8B	POWER SEATS	8R
BATTERY/STARTING/CHARGING SYSTEMS		POWER WINDOWS	8S
DIAGNOSTICS	8A	REAR WINDOW DEFOGGER	8N
CHIME/BUZZER WARNING SYSTEM	8U	RESTRAINT SYSTEM	8M
HORNS	8G	SPEED CONTROL	8H
IGNITION SYSTEM	8D	TURN SIGNAL AND FLASHERS	8J
INSTRUMENT PANEL AND GAUGES	8E	WINDSHIELD WIPERS AND WASHERS	8K
LAMPS	8L	WIRING DIAGRAMS	8W
OVERHEAD CONSOLE	8C		
POWER LOCKS	8P		

BATTERY/STARTING/CHARGING SYSTEMS DIAGNOSTICS

CONTENTS

	page		page
ALTERNATOR TEST PROCEDURES ON VEHICLE	15	GENERAL INFORMATION	1
BATTERY TEST PROCEDURES ON-VEHICLE ...	2	IGNITION OFF DRAW (IOD)	7
FAULT CODES—ON BOARD DIAGNOSTICS ...	18	SPECIFICATIONS	23
		STARTER TEST PROCEDURES ON VEHICLE ...	9

GENERAL INFORMATION

• For Battery, Starter or Alternator Replacement, refer to Group 8B, Battery/Starter/Alternator Service. Group 8A, Battery/Starting/Charging Systems Diagnostics will cover diagnostics only.

The Battery, Starting, and Charging Systems operate in conjunction with one another, and must be thoroughly tested as a complete system. To enable the vehicle to start and charge properly, it must have a battery that will perform to specifications. The starter motor, alternator, wiring, and electronics also must perform within specifications. Group 8A will cover Starting (Fig. 1) and Charging System (Fig. 2) diagnostic procedures. These will be covered from the most basic conventional methods to On Board Diagnostics (OBD) built into the vehicle's electronics. The need for conventional testing equipment has not been elimi-

nated by the introduction of OBD. Frequent use of an ammeter, volt/ohmmeter, battery charger, carbon pile rheostat (load tester), and 12 volt (low wattage) test light will be required.

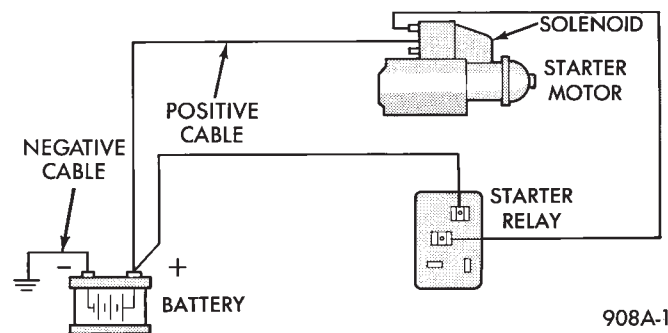

Fig. 1 Starting System Components

All front wheel drive vehicles are equipped with OBD and all OBD sensing systems are monitored by

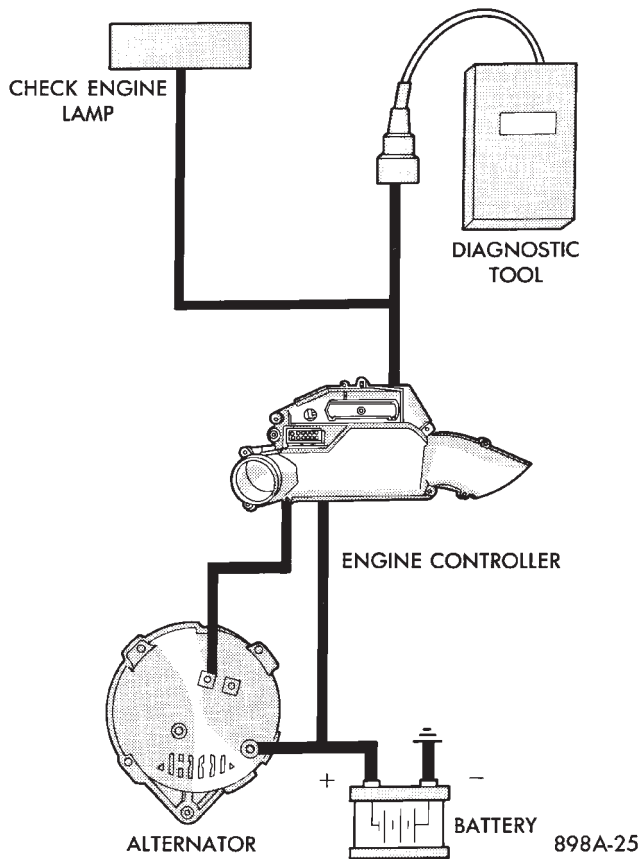

Fig. 2 Charging System Components

the Engine Control computer. The Engine Control computer will store in electronic memory, any detectable failure within the monitored circuits. It will retain this information for a period of 50 engine starts, then erase the memory if the failure does not reoccur during that period. This also will translate a monitored failure in the form of a FAULT CODE when a readout command is given. A readout command can be made by turning the ignition switch to ON-OFF-ON-OFF-ON without starting the engine. The CHECK ENGINE LAMP on the instrument cluster will flash in predetermined sequences to show Fault Codes. However, the Check Engine Lamp cannot express fault codes for all failures. Fault codes are easier to obtain and more complete with the use of Diagnostic Tool (DRB II). This tool is plugged into the diagnostic connector located in the engine compartment (Fig. 2). Refer to the instructions provided with the (DRB II) tool being used.

For numbered Fault Codes pertaining to components within this particular Group, refer to Failure Codes—On Board Diagnostics in Group 8A. For other numbered Fault Codes not pertaining to this Group (8A), refer to On Board Diagnostics in the General Diagnosis section of Group 14, Fuel System for more information.

BATTERY TEST PROCEDURES ON-VEHICLE

INDEX

	page		page
Battery Charging	6	General Information	2
Battery Load Test	4	State of Charge Tests	3
Battery Open Circuit Voltage Test	4	Test Indicator	3
Causes of Battery Discharging	3		

GENERAL INFORMATION

The battery stores, stabilizes, and produces electrical current to operate various electrical systems in the vehicle. The determination of whether a battery is good or bad is made by its ability to accept a charge. It also must produce high-amperage current output over an extended period to be able to start the vehicle. The capability of the battery to store electrical current comes from a chemical reaction. This reaction takes place between the sulfuric acid solution electrolyte and the lead +/- plates in each cell of the battery. As the battery discharges, the plates react with the acid from the electrolyte. When the charging system charges the battery, the water is converted to sulfuric acid in the battery. The amount of acid, specific gravity in the electrolyte can be measured with a hydrometer. The factory

installed battery is equipped with a built-in hydrometer, as a test indicator (Figs. 3, 4 and 5) to assist in decide its state of charge. The factory installed battery is also sealed. Water cannot and should not be added.

The battery is vented to release gases that are created when the battery is being charged and discharged. The battery top, posts, and terminals should be cleaned when other under hood maintenance is performed (Fig. 3).

WARNING: DO NOT ASSIST BOOST, CHARGE, ADD WATER, OR LOAD TEST BATTERY WHEN ELECTROLYTE LEVEL IS BELOW THE TOP OF THE PLATES. PERSONAL INJURY MAY OCCUR.

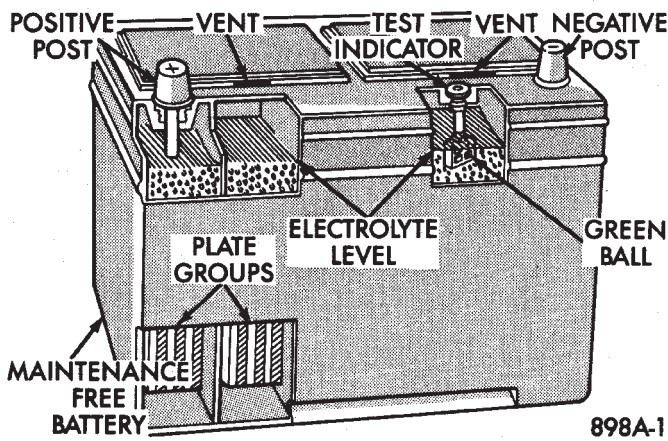

Fig. 3 Battery Construction and Test Indicator

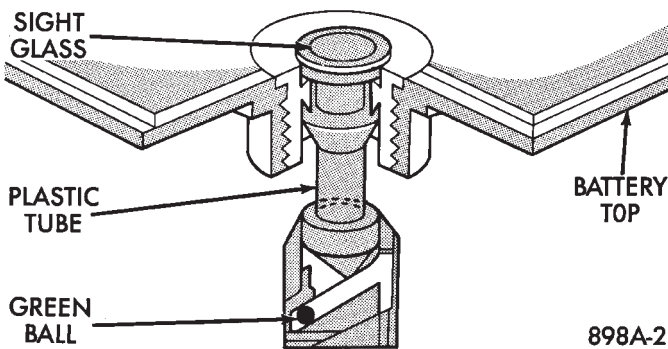

Fig. 4 Built in Test Indicator

TEST INDICATOR/STATE OF CHARGE		
100% ←	75% ←	○ REPLACE BATTERY
GREEN	BLACK	YELLOW 898A-3

Fig. 5 Test Indicator Sight Glass

When the electrolyte level is below the top of the plates a yellow or bright color indicator in sight glass (Figs. 4 and 5), the battery must be replaced. Refer to Test Indicator. The battery must be completely charged with a green color in sight glass. The top, posts, and terminals should be properly cleaned before diagnostic procedures are performed. Also refer to Group 8B, Battery/Starter/Alternator Service for additional information.

TEST INDICATOR

A test indicator a hydrometer viewed through a sight glass, is built into the top of battery case (Figs. 3, 4 and 5). This provides visual information for battery testing.

The test indicator sight glass is to be used with diagnostic procedures described in this Group.

It is important when using the Test Indicator that the battery be level and have a clean top to see the correct indications. A light may be required to view the Indicator.

WARNING: DO NOT USE OPEN FLAME NEAR BATTERY. EXPLOSIVE GASES FORM ABOVE BATTERY.

STATE OF CHARGE TESTS

USING TEST INDICATOR

The built-in test hydrometer (Figs. 3, 4 and 5) measures the specific gravity of the electrolyte. Specific Gravity (SG) of the electrolyte will show state-of-charge (voltage). The test indicator WILL NOT show cranking capacity of the battery. Refer to Battery Load Test for more information. Look into the sight glass (Figs. 4 and 5) and note the color of the indicator (Fig. 5). Refer to the following description as color show:

- GREEN = 75 to 100 state-of-charge
- BLACK OR DARK = 0 to 75 state-of-charge

The battery is adequately charged for further testing and may be returned to use. If the vehicle will not crank for a maximum 15 seconds, refer to BATTERY LOAD TEST in this Group for more information.

BLACK OR DARK = 0 to 75 state-of-charge

The battery is INADEQUATELY charged and must be charged until green dot is visible, (12.4 volts or greater) before the battery is tested or returned to use. Refer to Causes of Battery Discharging in this Group for more information.

YELLOW OR BRIGHT COLOR = Battery must be replaced.

WARNING: DO NOT CHARGE, ASSIST BOOST, LOAD TEST, OR ADD WATER TO THE BATTERY WHEN YELLOW OR BRIGHT COLOR DOT IS VISIBLE. PERSONAL INJURY MAY OCCUR.

A yellow or bright color dot shows electrolyte level in battery is below the test indicator (Fig. 5). Water cannot be added to a maintenance free battery. The battery must be replaced. A low electrolyte level may be caused by an over charging condition. Refer to Alternator Test Procedures on Vehicle.

CAUSES OF BATTERY DISCHARGING

It is normal to have a small 5 to 30 milliamperes continuous electrical draw from the battery. This draw will take place with the ignition in the OFF position, and the courtesy, dome, storage compart-

ments, and engine compartment lights OFF. The continuous draw is due to various electronic features or accessories that require electrical current with the ignition OFF to function properly. When a vehicle is not used over an extended period of approximately 20 days the Main Fusible Link Connector (Fig. 6) should be disconnected. This is located near the battery on the engine wiring harness. Disconnection of this connector will help prevent battery discharging.

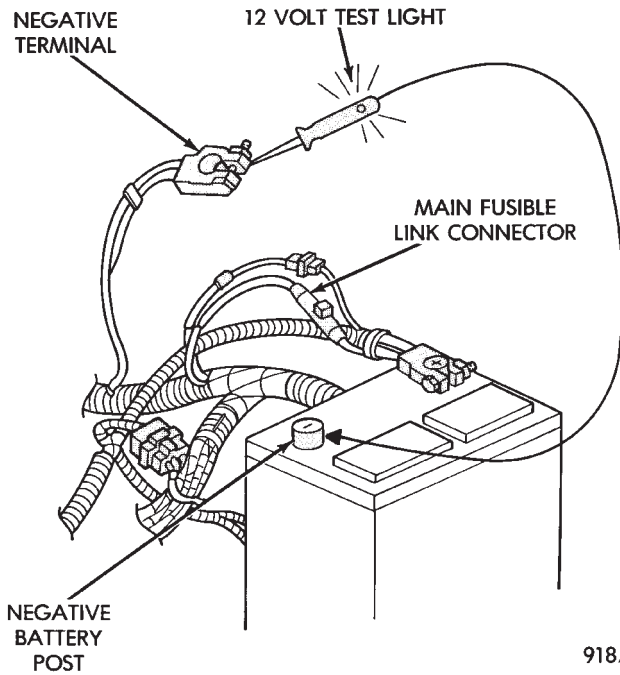

918A-1

Fig. 6 Main Fusible Link Connector

ABNORMAL BATTERY DISCHARGING

- (1) Corroded battery posts, cables or terminals.
- (2) Loose or worn alternator drive belt.
- (3) Electrical loads that exceed the output of the charging system due to equipment or accessories installed after delivery.
- (4) Slow driving speeds in heavy traffic conditions or prolonged idling with high-amperage electrical systems in use.
- (5) Defective electrical circuit or component causing excess Ignition Off Draw (IOD). Refer to Ignition Off Draw (IOD).
- (6) Defective charging system.
- (7) Defective battery.

BATTERY OPEN CIRCUIT VOLTAGE TEST

An open circuit voltage no load test shows the state of charge of a battery. Also, if it will pass a load test of 50 percent of the battery cold crank rating. Refer to Battery Load Test. If a battery has an open circuit voltage reading of 12.4 volts or greater, and will not endure a load test, it is defective and replacement would be required. To test open circuit voltage, perform the following operation:

- (1) Remove both battery cables, negative first. If the

battery has been boosted, charged, or loaded just prior to this operation, allow the battery a few minutes to stabilize.

- (2) Using a voltmeter connected to the battery posts and measure the open circuit voltage (Fig. 7).

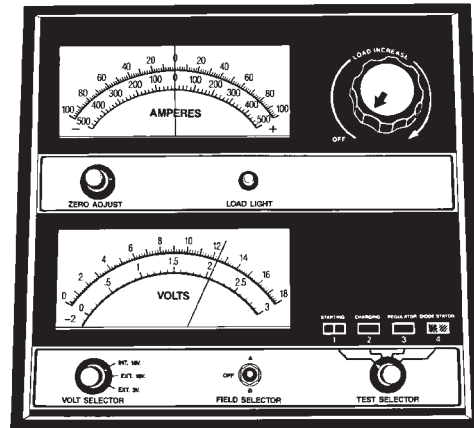

898A-7

Fig. 7 Testing Open Circuit Voltage

This voltage reading will show the state of charge of the battery. It will not reveal battery cranking capacity (Fig. 8).

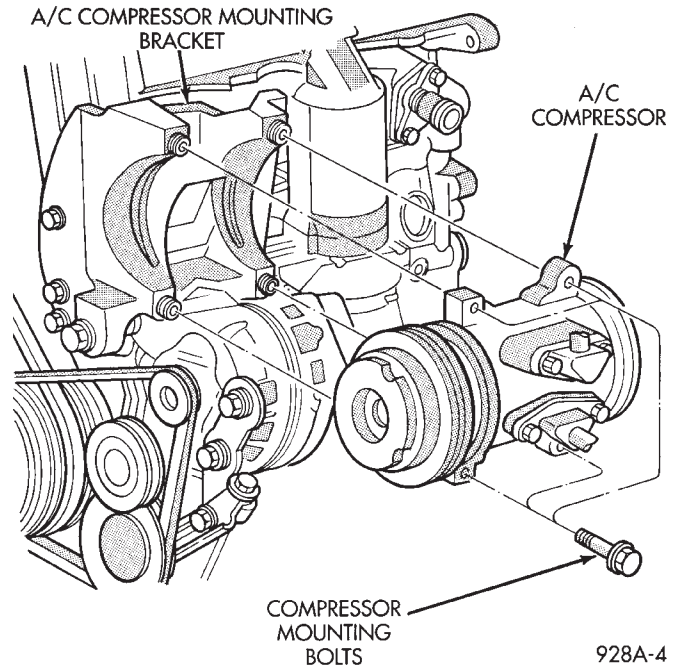

928A-4

Fig. 8 BATTERY OPEN CIRCUIT VOLTAGE

BATTERY LOAD TEST

A fully charged battery must have reserve cranking capacity. This will enable the starter motor and ignition system enough power to start the engine over a broad range of ambient temperatures. A battery load test will verify the actual cranking performance based on the cold crank rating of the battery.

WARNING: IF BATTERY SHOWS SIGNS OF FREEZING, LEAKING, LOOSE POSTS, OR EXCESSIVELY LOW ELECTROLYTE LEVEL, DO NOT TEST. ACID BURNS OR AN EXPLOSIVE CONDITION MAY RESULT.

(1) Remove both battery cables, **NEGATIVE** first. Battery top, cables and posts should be clean. If green dot is not visible in indicator, charge the battery. Refer to Battery Charging Procedures.

(2) Use a suitable Volt/Ammeter/Load tester (Fig. 9) connected to the battery posts (Fig. 10). Check the open circuit voltage of the battery. Voltage should be equal to or greater than 12.4 volts with the green dot visible in test indicator.

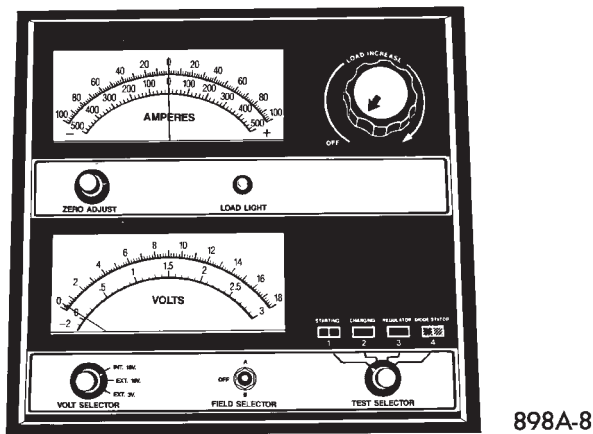

Fig. 9 Volt-Ammeter-Load Tester

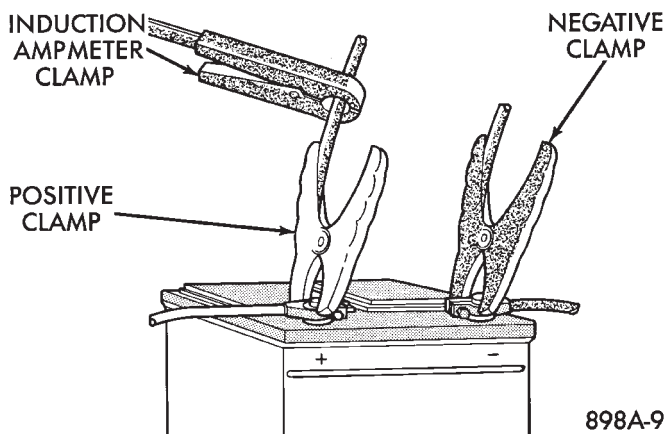

Fig. 10 Volt-Ammeter-Load Tester Connections

(3) Rotate the load control knob of the Carbon pile rheostat to apply a 300 amp load. Apply this load for 15 seconds to remove the surface charge from the battery, and return the control knob to off (Fig. 11).

(4) Allow the battery to stabilize for 15 seconds, and then verify open circuit voltage.

(5) Rotate the load control knob on the tester to maintain 50% of the battery cold crank rating for a minimum 15 seconds (Fig. 12).

After 15 seconds, record the loaded voltage reading and return the load control to off.

(6) Voltage drop will vary according to battery temperature at the time of the load test. Battery temperature can be estimated by the temperature of exposure over the preceding several hours. If the battery has been charged, boosted, or loaded a few minutes prior to the test, the battery would be slightly warmer. Refer to Fig. 13 for proper loaded voltage reading.

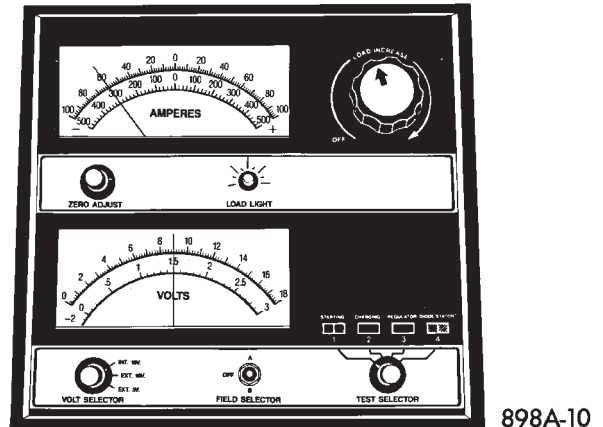

Fig. 11 Remove Surface Charge from Battery

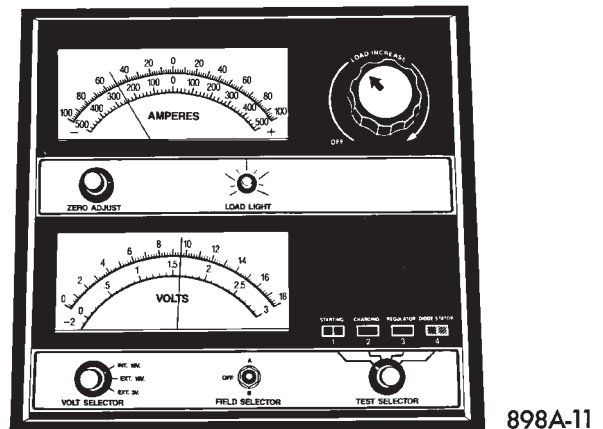

Fig. 12 Load 50% Cold Crank Rating

Minimum Voltage	Temperature
	C°
9.6	21 and above
9.5	16
9.4	10
9.3	4
9.1	-1
8.9	-7
8.7	-12
8.5	-18

Fig. 13 LOAD TEST TEMPERATURE

(7) If battery passes load test, it is in good condition and further tests are not necessary. If it fails load test, it should be replaced.

BATTERY CHARGING

A battery is considered fully charged when it will meet all the following requirements:

- It has an open circuit voltage charge of at least 12.4 volts (Fig. 8).
- It passes the 15 second load test (Fig. 13).
- The built in test indicator dot is GREEN (Fig. 5).

The battery cannot be refilled with water, it must be replaced.

WARNING: DO NOT CHARGE A BATTERY THAT HAS EXCESSIVELY LOW ELECTROLYTE LEVEL. BATTERY MAY SPARK INTERNALLY AND EXPLODE.

EXPLOSIVE GASES FORM OVER THE BATTERY. DO NOT SMOKE, USE FLAME, OR CREATE SPARKS NEAR BATTERY.

DO NOT ASSIST BOOST OR CHARGE A FROZEN BATTERY. BATTERY CASING MAY FRACTURE.

BATTERY ACID IS POISON, AND MAY CAUSE SEVERE BURNS. BATTERIES CONTAIN SULFURIC ACID. AVOID CONTACT WITH SKIN, EYES, OR CLOTHING. IN THE EVENT OF CONTACT, FLUSH WITH WATER AND CALL PHYSICIAN IMMEDIATELY. KEEP OUT OF REACH OF CHILDREN.

CAUTION: Disconnect the battery NEGATIVE cable first (Fig. 14) before charging battery to avoid damage to electrical systems. Do not exceed 16.0 volts while charging battery. Refer to the instructions supplied with charging equipment

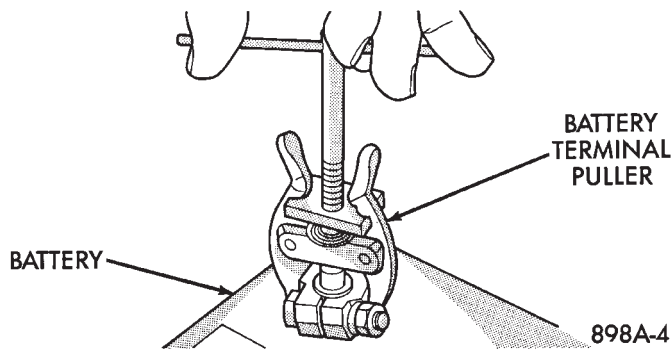

Fig. 14 Disconnect Negative Battery Cable

Battery electrolyte will bubble inside of battery case while being charged properly. If the electrolyte boils violently, or is discharged from the vent holes while charging, immediately reduce charging rate or turn off charger. Evaluate battery condition. Battery damage may occur if charging is excessive.

Some battery chargers are equipped with polarity sensing devices to protect the charger or battery from being damaged if improperly connected. If the battery state of charge is too low for the polarity sensor to detect, the sensor must be

bypassed for charger to operate. Refer to operating instructions provided with battery charger being used.

CAUTION: Charge battery until test indicator appears green. Do not overcharge.

It may be necessary to jiggle the battery or vehicle to bring the green dot in the test indicator into view.

After the battery has been charged to 12.4 volts or greater, perform a load test to determine cranking capacity. Refer to BATTERY LOAD TEST in this Group. If the battery will endure a load test, return the battery to use. If battery will not endure a load test, it must be replaced. Properly clean and inspect battery hold downs, tray, terminals, cables, posts, and top before completing service. Also refer to Group 8B, Battery/Starter/Alternator Service.

CHARGING TIME REQUIRED

The time required to charge a battery will vary depending upon the following factors:

- SIZE OF BATTERY

A completely discharged of a large heavy-duty battery requires more than twice the recharging time as a completely discharged small capacity battery (Fig. 15).

Charging Amperage	5 Amps	10 Amps	20 Amps
Open Circuit Voltage	Hours Charging at 21°C		
12.25 to 12.39	6 Hrs.	3 Hrs.	1.5 Hr.
12.00 to 12.24	8 Hrs.	4 Hrs.	2 Hrs.
11.95 to 12.09	12 Hrs.	6 Hrs.	3 Hrs.
10.00 to 11.95	14 Hrs.	7 Hrs.	3.5 Hrs.
10.00 to 0	See Charging Completely Discharged Battery		

928A-19

Fig. 15 BATTERY CHARGING TIME

- TEMPERATURE

A longer time will be needed to charge a battery at -18°C (0°F) than at 27°C (80°F). When a fast charger is connected to a cold battery, current accepted by battery will be very low at first. In time, the battery will accept a higher rate as battery warms.

- CHARGER CAPACITY

A charger which can supply only five amperes will require a much longer period of charging than a charger that can supply 30 amperes or more.

- STATE-OF-CHARGE

A completely discharged battery requires more charging time than a partially charged battery. Electrolyte is nearly pure water in a completely discharged battery. At first, the charging current amperage will be low. As water is converted to sulfuric acid inside the battery, the current amp rate will rise. Also, the specific gravity of the electrolyte will rise, bringing the green dot (Fig. 5).

WARNING: NEVER EXCEED 20 AMPS WHEN CHARGING A COLD -1°C (30°F) BATTERY. PERSONAL INJURY MAY RESULT.

CHARGING COMPLETELY DISCHARGED BATTERY

The following procedure should be used to recharge a completely discharged battery. Unless procedure is properly followed, a good battery may be needlessly replaced (Fig. 16).

Voltage	Hours
16.0 volts or more	up to 4 hrs.
14.0 to 15.9 volts	up to 8 hrs.
13.9 volts or less	up to 16 hrs.

918A-6

Fig. 16 CHARGE RATE

(1) Measure the voltage at battery posts with a voltmeter accurate to 1/10 volt (Fig. 17). If below 10 volts, charge current will be low, and it could take some time before it accepts a current in excess of a few milliamperes. Such low current may not be detectable on amp meters built into many chargers.

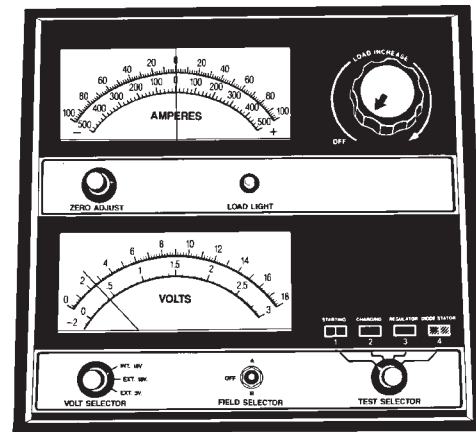

898A-12

Fig. 17 Voltmeter Accurate to 1/10 Volt (Connected)

(2) Connect charger leads. Some chargers feature polarity protection circuitry that prevents operation unless charger is connected to battery posts correctly. A completely discharged battery may not have enough voltage to activate this circuitry. This may happen though the leads are connected properly.

(3) Battery chargers vary in the amount of voltage and current they provide. For the time required for the battery to accept measurable charger current at various voltages, refer to Fig. 16. If charge current is still not measurable after charging times, the battery should be replaced. If charge current is measurable during charging time, the battery may be good, and charging should be completed in the normal manner.

IGNITION OFF DRAW (IOD)

GENERAL INFORMATION

A normal electrical system will draw from 5 to 30 milliamperes from the battery. This is with the ignition in the OFF position, and all non-ignition controlled circuits in proper working order. The amount of IOD will depend on body model and electrical components. A vehicle that has not been operated for an extended period approximately 20 days may discharge the battery to an inadequate level. In this case, the MAIN Fusible Link Connector should be disconnected. The Main Fusible Link connector is located rearward of the battery on the engine wiring harness (Fig. 18).

If the IOD is over 30 milliamperes, the defect must be found and corrected before replacing the battery. Usually, the battery can be charged and returned to service (Fig. 15).

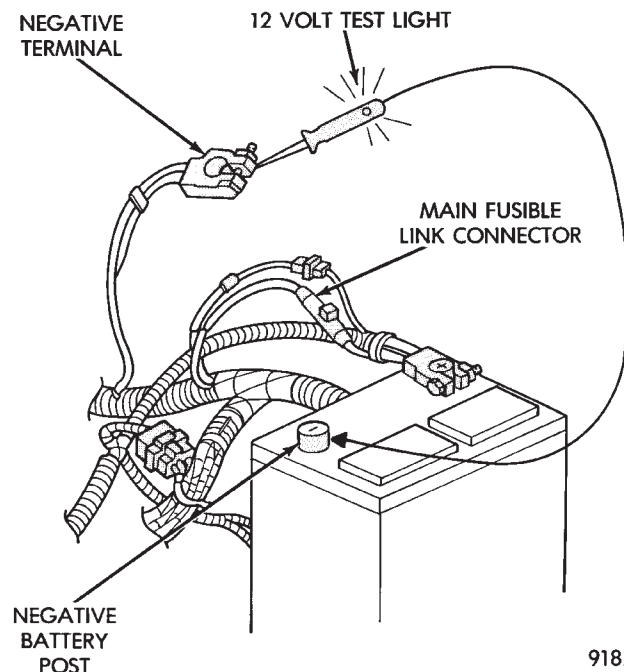

918A-1

Fig. 18 IOD Test

IGNITION OFF DRAW (IOD) TESTS

VEHICLES WITHOUT ELECTRONIC AUTOMATIC TRANSMISSION

Testing for HIGHER AMPERAGE IOD must be performed first to prevent damage to most milliamp meters.

A standard 12 volt test light and a milliamp meter that is equipped with two leads must be used for the following tests. The milliamp meter should be able to handle up to two amps.

(1) Verify that all electrical accessories are OFF. Turn off all lights, close trunk lid, close glove box door, turn off sun visor vanity lights, close all doors and remove ignition key. Allow the Illuminated Entry System if equipped to time out in approximately 30 seconds.

(2) Verify the engine compartment lamp is working by

opening/closing hood. Remove the lamp.

(3) Disconnect negative battery cable (Fig. 14).

(4) Connect a typical 12-volt test light low wattage lamp between the negative cable clamp and the negative battery post (Fig. 18). The test light may be brightly lit for up to three minutes or may not be lit at all depending on the body model or electronic components on the vehicle.

(a) The term brightly used throughout the following tests. This implies the brightness of the test light will be the same as if it were connected across the battery posts. This would be with a fully charged battery.

(b) The test light or the milliamp meter **MUST** be positively connected to the battery post and the battery cable during all IOD testing.

(c) Do not allow the test light or the milliamp meter to become disconnected during any of the IOD tests. If this happens, the electronic timer functions will be activated and all IOD tests must be repeated from the beginning. Clamp the test light at both ends to prevent accidental disconnection.

(d) After three minutes time has elapsed, the test light should turn off or be dimly lit depending on the electronic components on the vehicle. If the test light remains brightly lit, do not disconnect test light. Disconnect each fuse or circuit breaker (refer to Group 8W, Wiring Diagrams) until test light is either off or dimly lit. This will eliminate higher amperage IOD. It is now safe to install milliamp meter to check for low amperage IOD.

(e) Possible sources of high IOD are usually vehicle trunk lamp, glove compartment, luggage compartment and etc..

(f) If test light is still **BRIGHTLY** lit after disconnecting each fuse and circuit breaker, disconnect the wiring harness from the alternator. Refer to Alternator Testing. Do not disconnect test light.

CAUTION: The last test has higher amperage IOD must be performed before proceeding with low amperage IOD tests. The higher amperage IOD must be eliminated before hooking up milliamp meter to check for low amperage IOD. If higher amperage IOD has not been eliminated, milliamp meter may be damaged. Most milliamp meters will not handle over one or two amps. Do not hook up meter if test light is glowing brightly. Refer to maximum amperage specifications and instructions supplied with milliamp meter.

After higher amperage IOD has been corrected, low amperage IOD may be checked. The **MAXIMUM IOD = 30 MILLIAMPERES.**

(5) With test light still connected, connect milliamp meter between battery negative post and negative battery cable (Fig. 19). Do not open any doors or turn on any electrical accessories with the test light disconnected and the milliamp meter connected. Meter may be damaged.

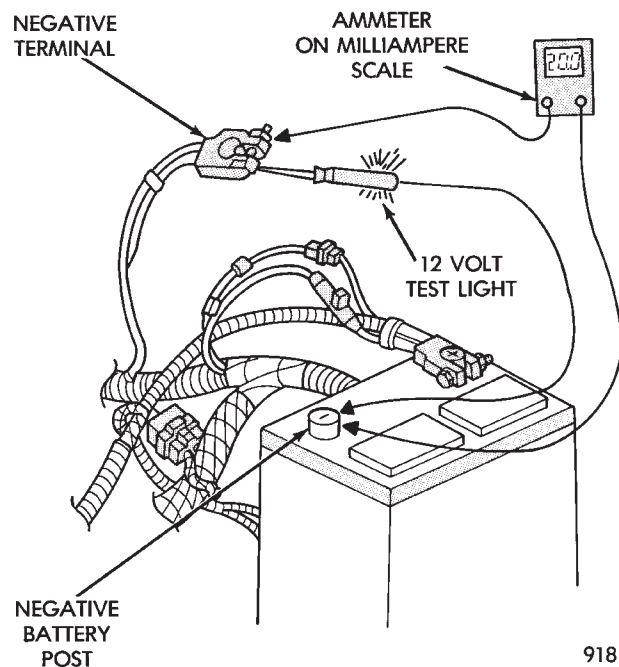

918A-2

Fig. 19 Low Amperage IOD Test

(6) Disconnect test light. Milliamp meter reading should be less than 30 milliamperes. If low amperage IOD is not within specifications, disconnect:

(a) The 60 way connector at the Engine Controller computer located outboard of the battery. Refer to Group 8D, Ignition, for more information.

(b) The 25 way connectors on the Body Controller computer, if equipped.

(c) The circuits to the clock and radio.

(d) The wiring harness from the alternator. Refer to Alternator Testing in this Group.

Check each component until excessive IOD is found.

Each time the test light or milliamp meter is disconnected and connected, all electronic timer functions will be activated. Tests must be repeated from the beginning.

Test light or meter **MUST** remain connected for all tests.

VEHICLES WITH ELECTRONIC AUTOMATIC TRANSMISSION

This vehicle will have temporary high IOD of 5 amps or more for up to 25 minutes. This higher IOD can often mask another problem and should be considered when performing IOD testing.

If high or low IOD is suspected, allow an additional 25 minutes (minimum) of electronic shut off time.

To defeat the timer, disconnect the 60-way connector on the Transmission Controller. This computer is located behind the right front strut tower.

STARTER TEST PROCEDURES ON VEHICLE

INDEX

	page		page
Diagnostic Preparation	9	Starter Feed Circuit Resistance Test	11
General Information	9	Starter Feed Circuit Tests	9
Starter Control Circuit Tests	12		

GENERAL INFORMATION

The starting system (Fig. 1) has:

- Ignition switch
- Starter relay (Fig. 2)
- Neutral starting and back-up switch with automatic transmissions only
- Wiring harness
- Battery
- Starter motor with an integral solenoid

These components form two separate circuits. A high amperage circuit that feeds the starter motor up to 300+ amps, and a control circuit that operates on less than 20 amps.

DIAGNOSTIC PREPARATION

Before proceeding with starting system diagnostics, verify:

- (1) The battery top, posts, and terminals are clean.
- (2) The alternator drive belt tension and condition is correct.
- (3) The battery state-of-charge is correct.
- (4) The battery will endure load test.
- (5) The battery cable (+/-) connections at the starter and engine block are clean and free from corrosion.
- (6) The wiring harness connectors and terminals are clean and free from corrosion.
- (7) Proper circuit grounding.
- (8) Refer to Starter System Diagnostics (Fig. 3).

STARTER FEED CIRCUIT TESTS

The following procedure will require a suitable volt-ampere tester (Fig. 4).

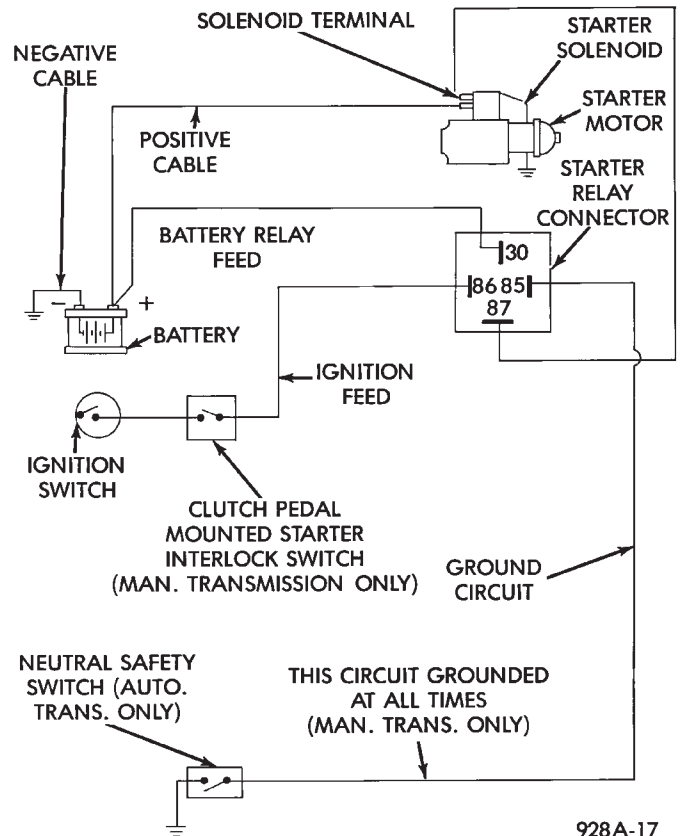

Fig. 1 Starting System—Typical Components/Wiring

CAUTION: Ignition system also must be disabled to prevent engine start while performing the following tests.

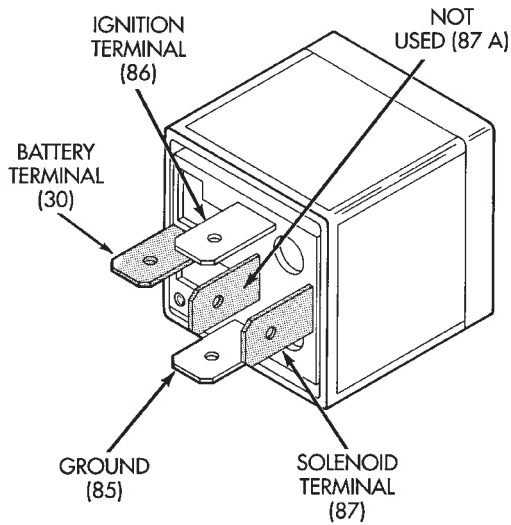
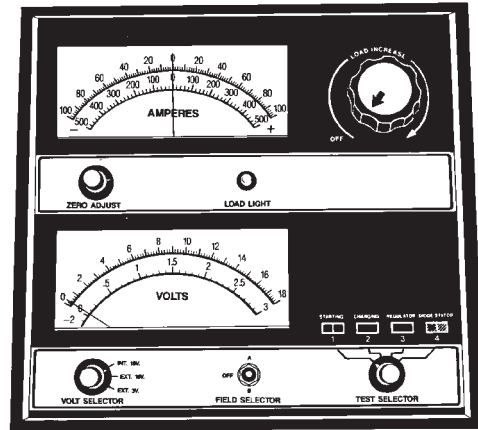

Fig. 2 Starter Relay

J928B-1



898A-8

Fig. 4 Volt Ampere Tester

- PLACE GEAR SELECTOR IN PARK OR NEUTRAL AND SET PARK BRAKE OR EQUIVALENT.
- VERIFY BATTERY STATE-OF-CHARGE AND CRANKING CAPACITY, SEE BATTERY SECTION.
- CLEAN BATTERY TOP, POSTS, AND TERMINALS.
- VERIFY ALTERNATOR DRIVE BELT TENSION.
- DISCONNECT AND GROUND COIL CABLE.

TEST CONDITIONS:

SYMPTOM	SYMPTOM	SYMPTOM	SYMPTOM	SYMPTOM
STARTER FAILS TO ENGAGE. NO SOUNDS	STARTER FAILS TO ENGAGE. SOLENOID OR RELAY CLICKS	STARTER ENGAGES, FAILS TO TURN ENGINE. DOME LIGHT DIMS	STARTER ENGAGES, DRIVE CLUTCH SPINS OUT	STARTER DOES NOT DISENGAGE AFTER ENGINE STARTS
<p>POSSIBLE CAUSE</p> <p>STARTER CONTROL CIRCUIT FAULTY</p> <p>IGNITION SWITCH FAULTY</p> <p>NEUTRAL SAFETY SWITCH (AUTO TRANS.) FAULTY OR MISADJUSTED</p> <p>CLUTCH PEDAL SWITCH (MANUAL TRANS.) FAULTY OR MISADJUSTED</p> <p>STARTER RELAY FAULTY</p> <p>STARTER ASSEMBLY FAULTY</p>	<p>POSSIBLE CAUSE</p> <p>RESISTANCE TOO HIGH IN STARTER FEED CIRCUIT</p> <p>STARTER CONTROL CIRCUIT FAULTY</p> <p>STARTER SOLENOID FAULTY</p> <p>STARTER ASSEMBLY FAULTY</p>	<p>POSSIBLE CAUSE</p> <p>RESISTANCE TOO HIGH IN STARTER FEED CIRCUIT</p> <p>ENGINE SEIZED</p> <p>STARTER ASSEMBLY FAULTY</p> <p>REFER TO APPROPRIATE GROUP AND SECTION OF THIS MANUAL FOR PROPER SERVICE AND TEST PROCEDURES FOR THE COMPONENTS INVOLVED</p>	<p>POSSIBLE CAUSE</p> <p>DRIVE CLUTCH FAULTY</p> <p>BROKEN TEETH ON RING GEAR</p> <p>STARTER ASSEMBLY FAULTY</p>	<p>POSSIBLE CAUSE</p> <p>IGNITION SWITCH FAULTY</p> <p>STARTER RELAY FAULTY</p> <p>STARTER ASSEMBLY FAULTY</p>

928A-11

Fig. 3 STARTER SYSTEM DIAGNOSTICS

(1) Connect a volt-ampere tester (Fig. 4) to the battery terminals (Fig. 5). Refer to the operating instructions provided with the tester being used.

(2) Disable ignition system as follows:

• **VEHICLES WITH CONVENTIONAL DISTRIBUTORS:** Disconnect the ignition coil cable from the distributor cap. Connect a suitable jumper wire between the coil cable end-terminal and a good body ground (Fig. 6).

• **VEHICLES WITH DIRECT IGNITION SYSTEM:** Disconnect the ignition coils electrical connector (Fig. 7).

(3) Verify that all lights and accessories are OFF, and the transmission shift selector is in the PARK. Set parking brake.

(4) Rotate and hold the ignition switch in the START position. Observe the volt-ampere tester (Fig. 8).

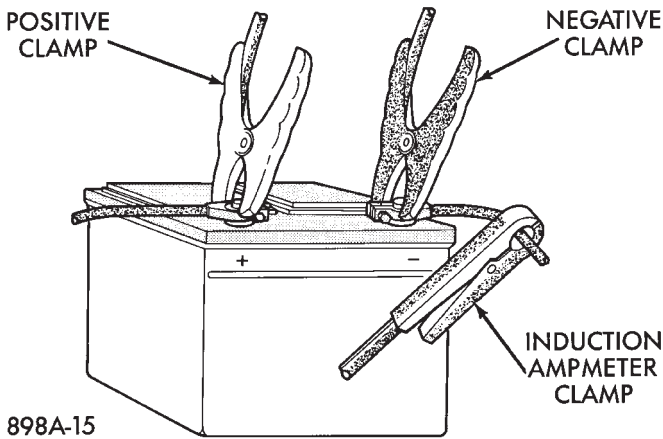

898A-15

Fig. 5 Volt-Ampere Tester Connections

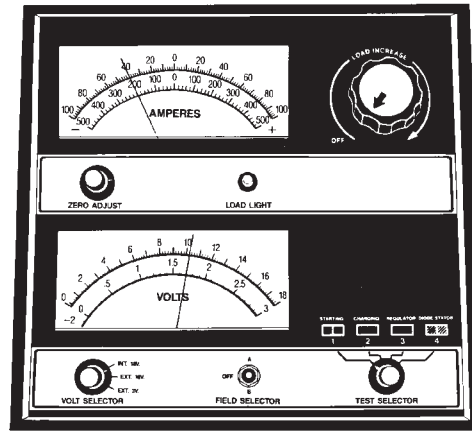

898A-21

Fig. 8 Starter Draw Tests

- If voltage reads 12.4 volts or greater and amperage reads 0 to 10 amps, go to starter control circuit test.

CAUTION: Do not overheat the starter motor or draw the battery voltage below 9.6 volts during cranking operations.

(5) After the starting system problems have been corrected, verify the battery state-of-charge and charge battery if necessary. Disconnect all testing equipment and connect ignition coil cable or ignition coil connector. Start the vehicle several times to assure the problem has been corrected.

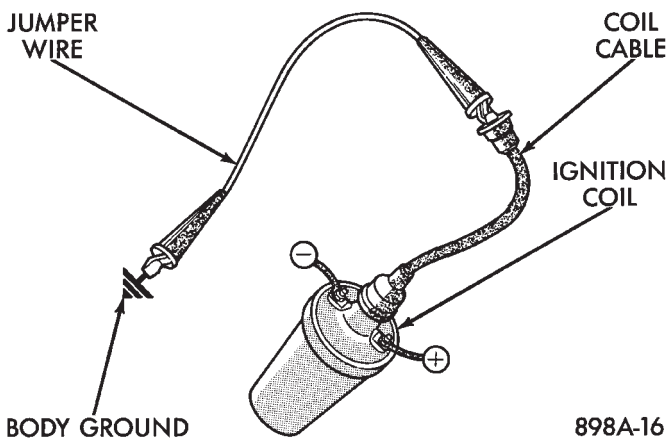

898A-16

Fig. 6 Ground Ignition Coil Cable

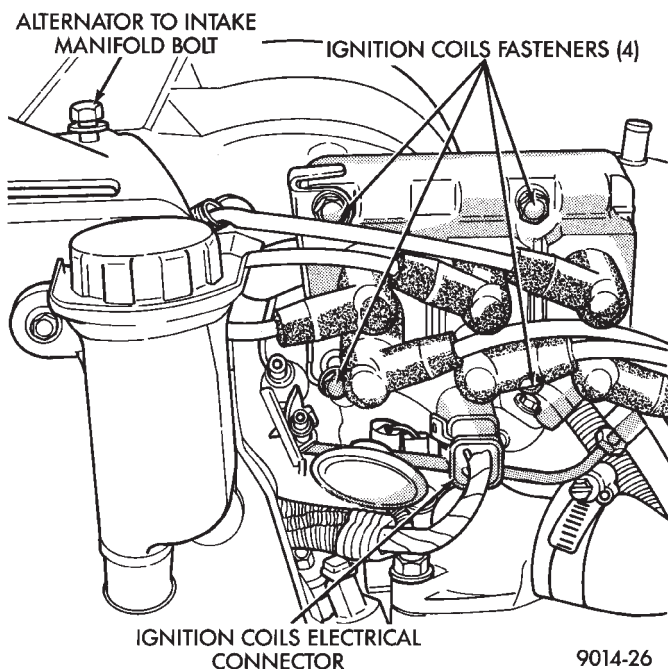

9014-26

Fig. 7 Ignition Coils Electrical Connection

- If voltage reads above 9.6 volts, and amperage draw reads above 250 amps, go to the starter feed circuit resistance test.

STARTER FEED CIRCUIT RESISTANCE TEST

Before proceeding with this operation, review Diagnostic Preparation and Starter Feed Circuit Tests in this Group. The following operation will require a voltmeter, accurate to 1/10 of a volt.

CAUTION: Ignition system also must be disabled to prevent engine start while performing the following tests.

- (1) Disable ignition system as follows:
 - VEHICLES WITH CONVENTIONAL DISTRIBUTORS
Disconnect the ignition coil cable from the distributor cap. Connect a suitable jumper wire between the coil cable end-terminal and a good body ground (Fig. 6).
 - VEHICLES WITH DIRECT IGNITION SYSTEM:
Disconnect the ignition coils electrical connector (Fig. 7).
- (2) With all wiring harnesses and components properly connected, perform the following:
 - (a) Connect the negative lead of the voltmeter to the negative battery post, and positive lead to the negative battery cable clamp (Fig. 9). Rotate and hold the ignition switch key in the START position. Observe the voltmeter. If voltage is detected, correct poor contact between cable clamp and post.

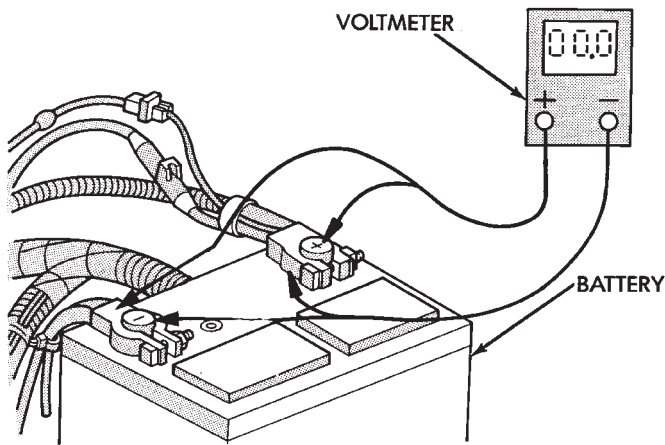

928A-5

Fig. 9 Test Battery Connection Resistance (Negative or Positive Posts)

(b) Connect positive lead of the voltmeter to the positive battery post, and negative lead to the positive battery cable clamp. Rotate and hold the ignition switch key in the START position. Observe the voltmeter. If voltage is detected, correct poor contact between the cable clamp and post.

(c) Connect negative lead of voltmeter to negative battery terminal, and positive lead to engine block near the battery cable attaching point (Fig. 10). Rotate and hold the ignition switch in the START position. If voltage reads above 0.2 volt, correct poor contact at ground cable attaching point. If voltage reading is still above 0.2 volt after correcting poor contacts, replace ground cable.

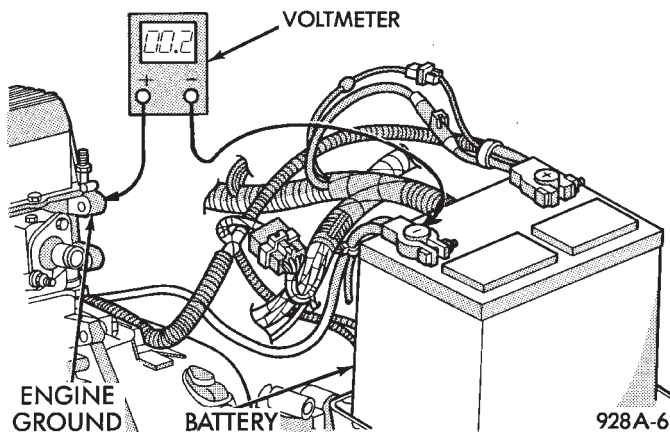

928A-6

Fig. 10 Test Ground Circuit Resistance

(3) Remove starter heat shield. Refer to Group 8B, Starter Replacement to gain access to the starter motor and solenoid connections. Perform the following steps:

(a) Connect positive voltmeter lead to the starter motor housing and the negative lead to the negative battery terminal (Fig. 11). Hold the ignition switch key in the START position. If voltage reads above 0.2 volt, correct poor starter to engine ground.

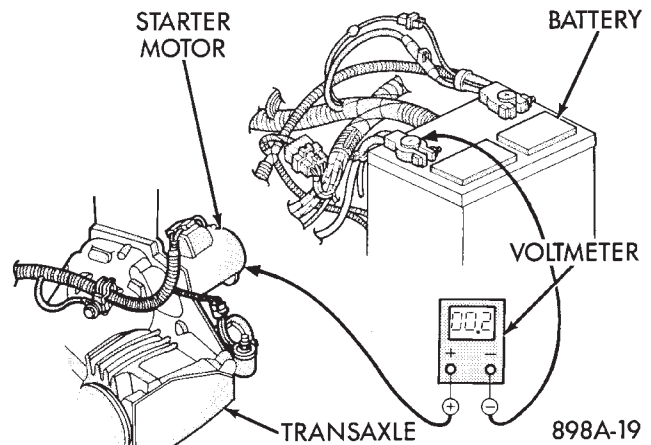

898A-19

Fig. 11 Test Starter Motor Ground—Typical

(b) Connect the positive voltmeter lead to the positive battery terminal, and negative lead to battery cable terminal on starter solenoid (Fig. 12). Rotate and hold the ignition switch in the START position. If voltage reads above 0.2 volt, correct poor contact at battery cable to solenoid connection. If reading is still above 0.2 volt after correcting poor contacts, replace positive battery cable.

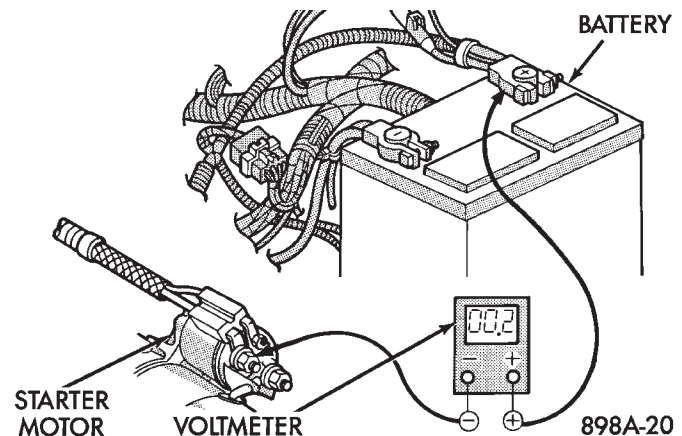

898A-20

Fig. 12 Test Positive Battery Cable Resistance

If resistance tests do not detect feed circuit failures, remove the starter motor and go to Bench Testing Starter Solenoid in this Group.

STARTER CONTROL CIRCUIT TESTS

The starter control circuit has:

- Starter solenoid
- Starter relay (Fig. 2)
- Neutral starting and back-up switch with automatic transmissions only
- Ignition switch
- Battery
- All related wiring and connections

CAUTION: Before performing any starter tests, the ignition system must be disabled.

VEHICLES EQUIPPED WITH A CONVENTIONAL DISTRIBUTOR: Disconnect coil wire from distributor cap center tower. Secure wire to a good ground to prevent engine from starting (Fig. 6).

• VEHICLES EQUIPPED WITH DIRECT IGNITION SYSTEM: Unplug the coils electrical connector (Fig. 7).

STARTER SOLENOID TEST

WARNING: CHECK TO ENSURE THAT THE TRANSMISSION IS IN THE PARK POSITION WITH THE PARKING BRAKE APPLIED

- (1) Verify battery condition. Battery must be in good condition with a full charge before performing any starter tests. Refer to Battery Tests.
- (2) Perform this starter solenoid test BEFORE performing the starter relay test.
- (3) Raise the vehicle.
- (4) Perform a visual inspection of the starter/starter solenoid for corrosion, loose connections or faulty wiring.
- (5) Lower the vehicle.
- (6) Locate the starter relay (Fig. 13).
- (7) Remove the starter relay from the connector.
- (8) Connect a remote starter switch or a jumper wire between the battery positive post and terminal 87 on

the starter relay connector. To determine the starter relay terminal numbers, refer to Fig. 14.

If engine cranks, starter/starter solenoid is good. Go to the Starter Relay Test.

If engine does not or solenoid chatters, check wiring and connectors from starter relay to starter solenoid for loose or corroded connections. Particularly at starter terminals.

Repeat test. If engine still fails to crank properly, trouble is within starter or starter mounted solenoid, and it must be removed for repairs. Refer to Group 8B, Battery/Starter/Alternator Service, Starter Replacement.

STARTER RELAY TEST

WARNING: CHECK TO ENSURE THAT THE TRANSMISSION IS IN THE PARK POSITION WITH THE PARKING BRAKE APPLIED

- (1) Verify battery condition. Battery must be in good condition with a full charge before performing any starter tests. Refer to Battery Tests.
- (2) Perform the preceding starter solenoid tests BEFORE performing starter relay tests. Refer to Starter Solenoid Test.
- (3) Locate and remove the starter relay (Fig. 13).
- (4) After the starter relay has been located and removed, refer to Starter Relay Tests (Fig. 14).

NEUTRAL STARTING AND BACK-UP SWITCH

AUTOMATIC TRANSMISSION ONLY

For electrical diagnostics, when checking starter circuits, refer to Starter Relay Tests (Fig. 14).

For removal and installation of neutral switch, refer to Neutral Starting and Back-up Switch in Group 21, Transaxle.

IGNITION SWITCH TEST

After testing starter solenoid and relay, test ignition switch and wiring. Refer to Group 8D, Ignition Systems or Group 8W, Wiring Diagrams. Check all wiring for opens or shorts, and all connectors for being loose or corroded.

BENCH TESTING STARTER SOLENOID

- (1) Disconnect field coil wire from field coil terminal (Fig. 15 or 16).
- (2) Check for continuity between solenoid terminal and field coil terminal with a continuity tester. Continuity should be detected (Fig. 17 or 18).
- (3) Check for continuity between solenoid terminal and solenoid housing (Fig. 19 or 20). Continuity should be detected. If continuity is detected, solenoid is good.
- (4) If continuity is not detected in either test, solenoid has an open circuit and is defective.

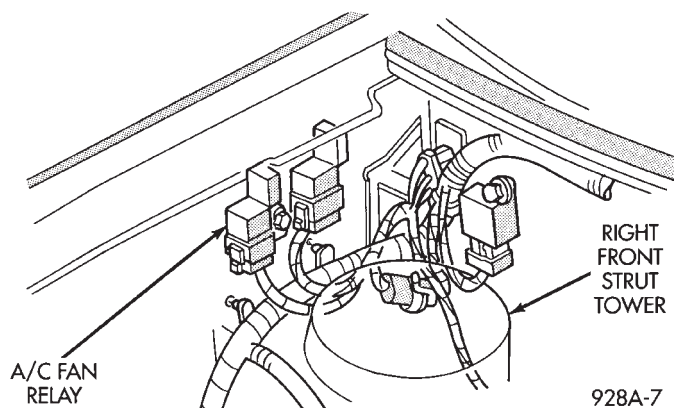
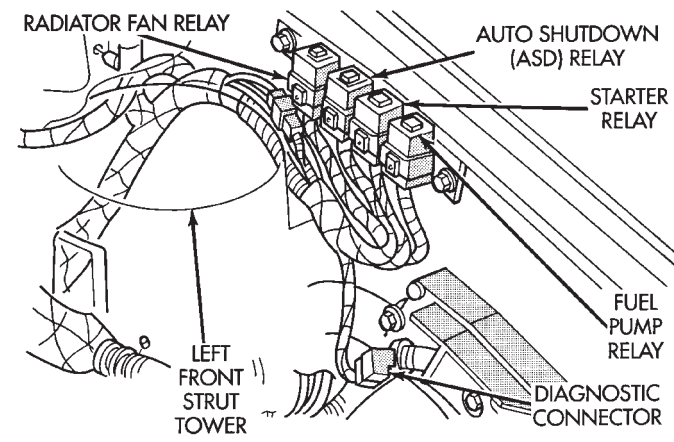
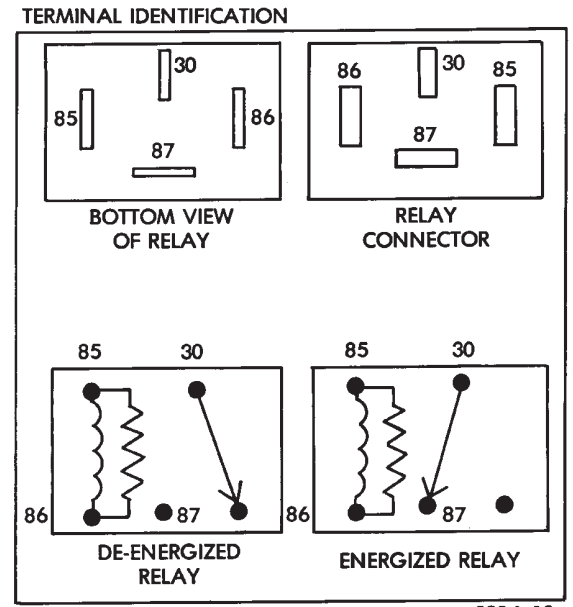
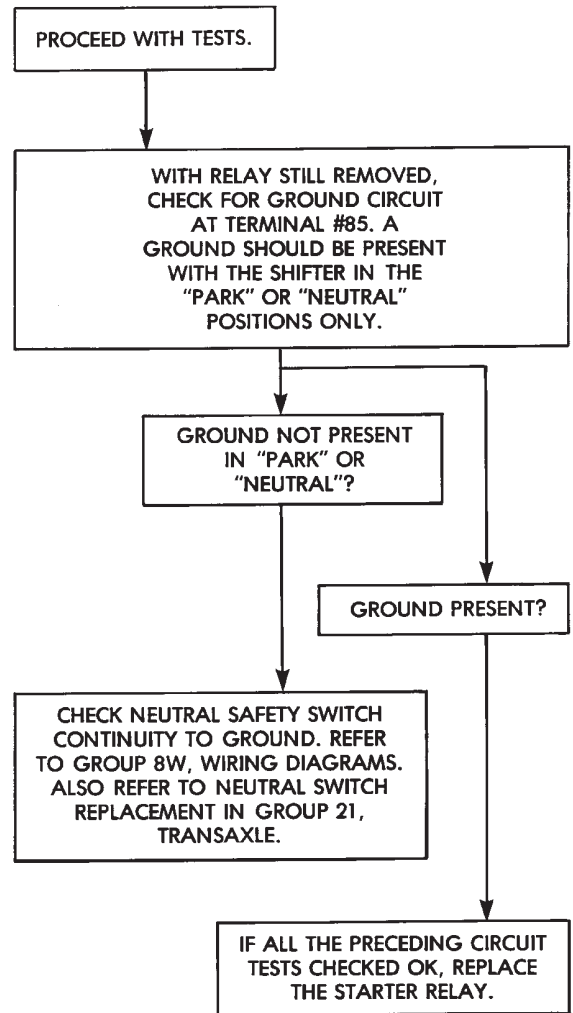
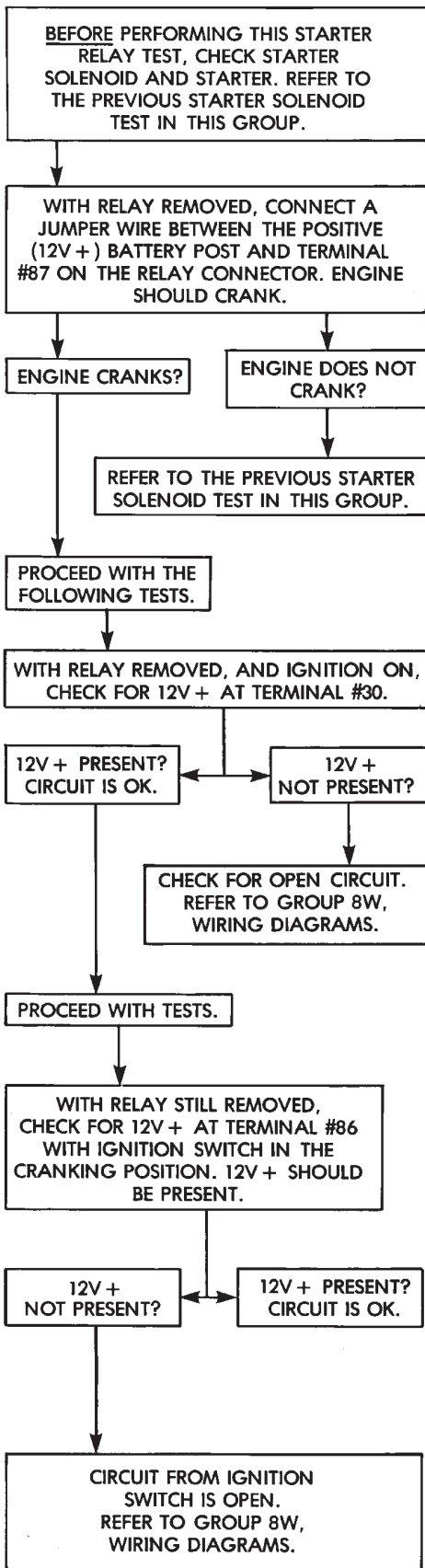

Fig. 13 Starter Relay Location



928A-18

Fig. 14 STARTER RELAY TESTS

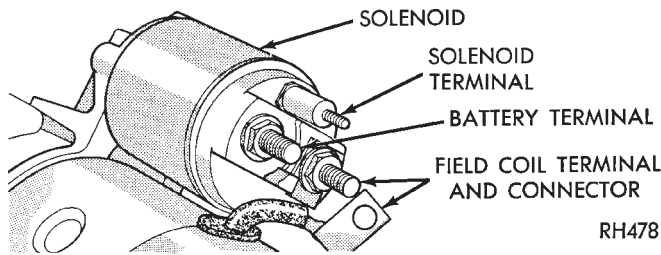

Fig. 15 Field Coil Wire Terminal—Bosch

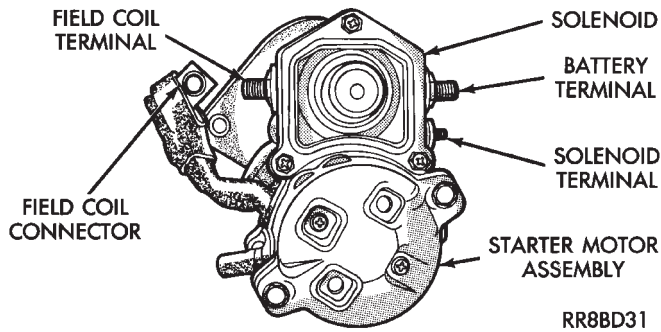

Fig. 16 Field Coil Wire Terminal—Nippondenso

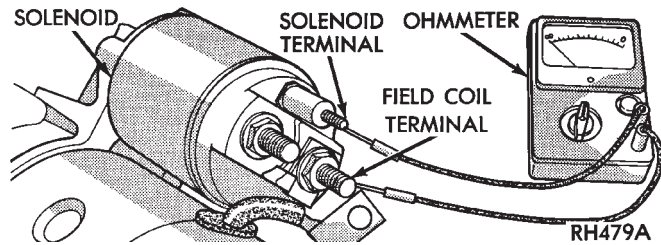

Fig. 17 Continuity Test Between Solenoid Terminal and Field Coil Terminal—Bosch

- BOSCH STARTERS: Replace the solenoid

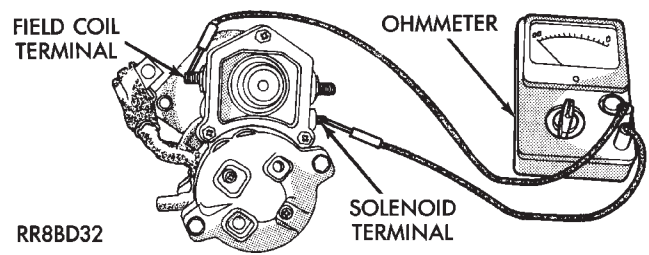

Fig. 18 Continuity Test Between Solenoid Terminal and Field Coil Terminal—Nippondenso

- NIPPONDENSO STARTERS: Replace the starter assembly

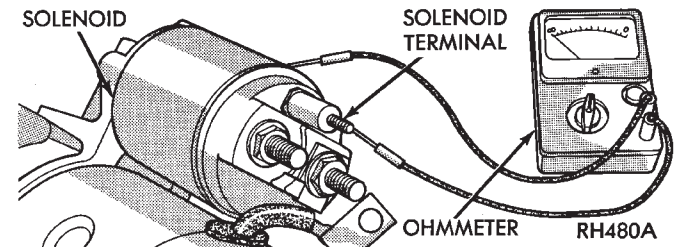

Fig. 19 Continuity Test Between Solenoid Terminal and Solenoid Case —Bosch

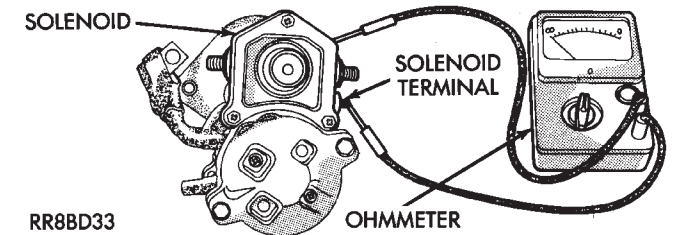

Fig. 20 Continuity Test Between Solenoid Terminal and Solenoid Case —Nippondenso

ALTERNATOR TEST PROCEDURES ON VEHICLE

INDEX

	page		page
Current Output Test	17	Output Wire Resistance Test	15

OUTPUT WIRE RESISTANCE TEST

The alternator output wire resistance test shows the amount of voltage drop across the alternator output wire between the alternator B+ terminal and the positive battery post.

PREPARATION

Before starting test, make sure the vehicle has a fully charged battery. Tests and procedures to check for a fully charged battery are shown in the Battery section of this Group.

- (1) Turn the ignition switch OFF.
- (2) Disconnect battery negative cable.

(3) Disconnect the alternator B+ output wire from the alternator output battery terminal (Fig. 1).

(4) Connect a 0-150 ampere scale (DC) ammeter in series between B+ terminal and output wire (Fig. 1 and 2). Connect positive lead to B+ terminal, and negative lead to output wire.

(5) Using 0-18 volt scale voltmeter, connect the positive lead to the disconnected (B+) output wire. Connect the negative lead to positive battery cable at positive post.

(6) Remove fresh air hose between Engine Controller and air cleaner if necessary.

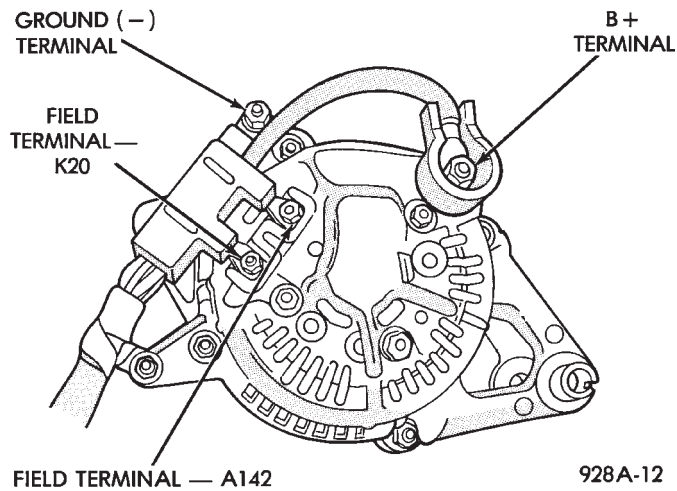

Fig. 1 Alternator Wiring Connections

(7) Connect jumper wire between a good ground, and K20 circuit terminal at the back of the alternator.

CAUTION: Do not connect the A142 circuit terminal (Fig. 1) to ground the Fusible link will burn.

(8) Connect an engine tachometer and connect battery negative cable.

(9) Connect a volt/amp tester equipped with a variable carbon pile rheostat between battery terminals (Fig. 3).

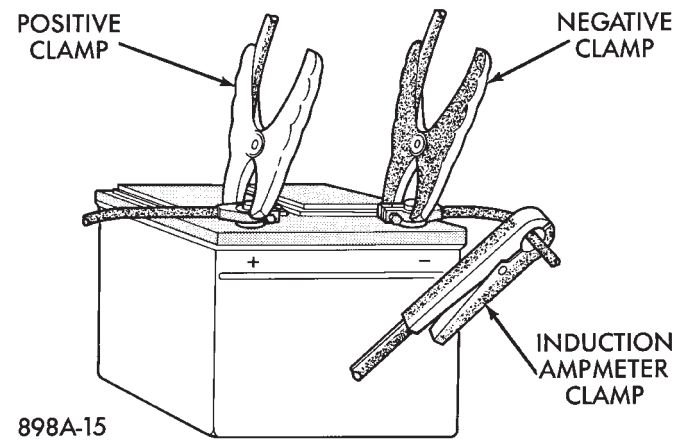

Fig. 3 Volt/Amp Tester Connections

Caution: Be sure the carbon pile is in OFF position before connecting leads.

TEST

(1) Start engine. Immediately after starting, reduce engine speed to idle.

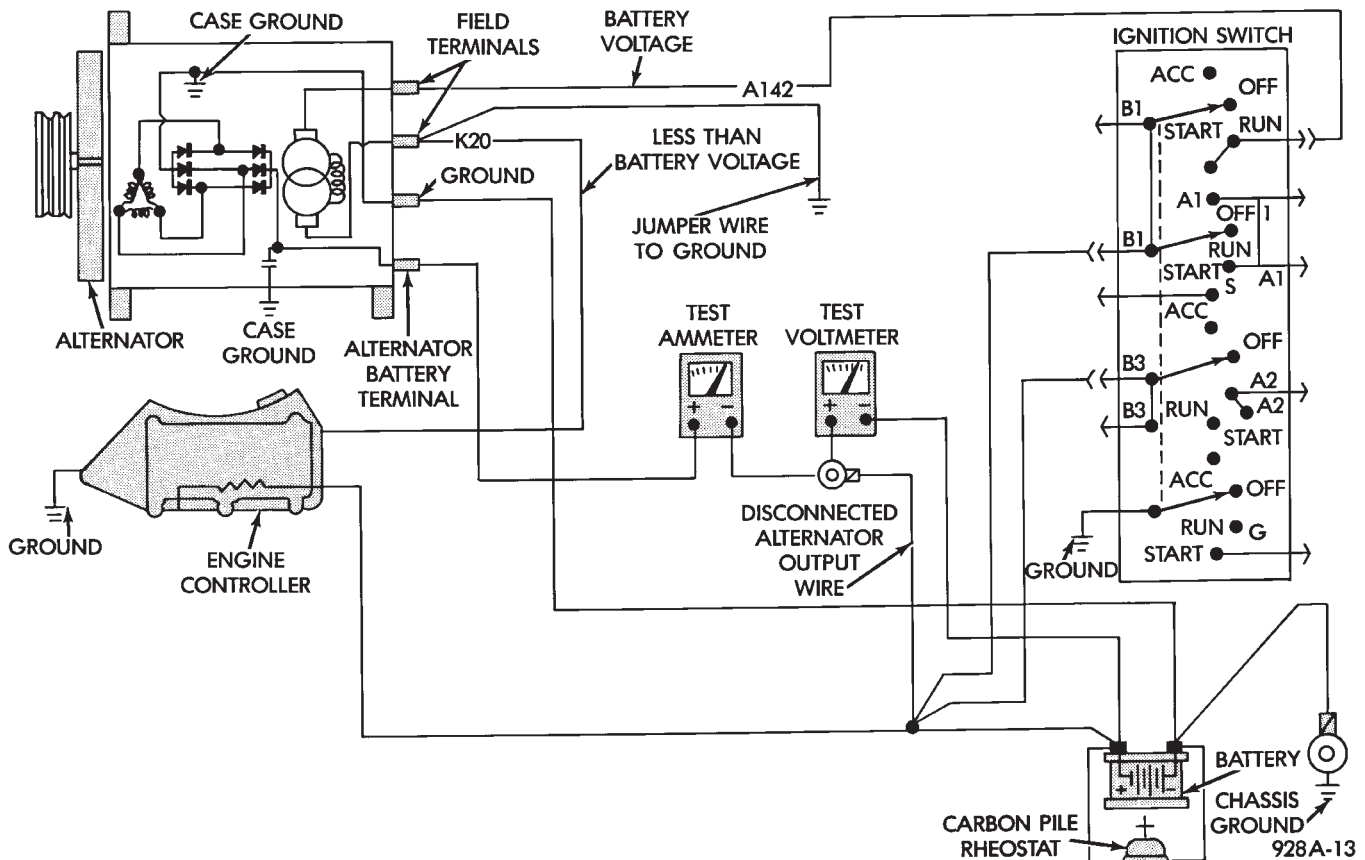

Fig. 2 Alternator Output Wire Resistance Test

(2) Adjust engine speed and carbon pile to maintain 20 amperes flowing in the circuit. Observe voltmeter reading. Voltmeter reading should not exceed 0.5 volts.

RESULTS

If a higher voltage drop is shown, inspect, clean and tighten all connections between alternator B+ terminal and battery positive post. A voltage drop test may be performed at each connection to locate a connection with excessive resistance. If resistance tests are satisfactory, reduce engine speed, turn off carbon pile, and turn off ignition switch.

- (1) Disconnect battery negative cable.
- (2) Remove test ammeter, voltmeter, carbon pile, and tachometer.
- (3) Remove jumper wire.
- (4) Connect output wire to B+ terminal.
- (5) Connect battery negative cable.
- (6) Connect fresh air hose between Engine Controller and air cleaner if removed.

CURRENT OUTPUT TEST

The current output test determines whether or not the alternator is capable of delivering its rated current output. For alternator identification and output amperage specifications, refer to Alternator Specifications.

For alternator maximum voltage at individual temperatures, refer to Alternator Output Voltage Specifications.

PREPARATION

Before starting any tests, make sure the vehicle has a fully charged battery. Tests and procedures to check for a fully charged battery are shown in Battery section.

- (1) Disconnect battery negative cable.
- (2) Disconnect output wire at the B+ terminal (Figs. 1 and 4).
- (3) Connect a 0-150 ampere scale (DC) ammeter in series between the B+ terminal and output wire. Connect Positive lead to B+ terminal and negative lead to output wire.
- (4) Using 0-18 voltmeter, connect the positive lead to B+ terminal (Figs. 2 and 4). Connect negative lead to a good ground.
- (5) Connect an engine tachometer and connect battery negative cable.
- (6) Connect a volt/amp tester equipped with a variable carbon pile rheostat between battery terminals (Fig. 5). Be sure carbon pile is in OFF position before connecting leads.
- (8) Remove fresh air hose between Engine Controller and air cleaner if necessary.

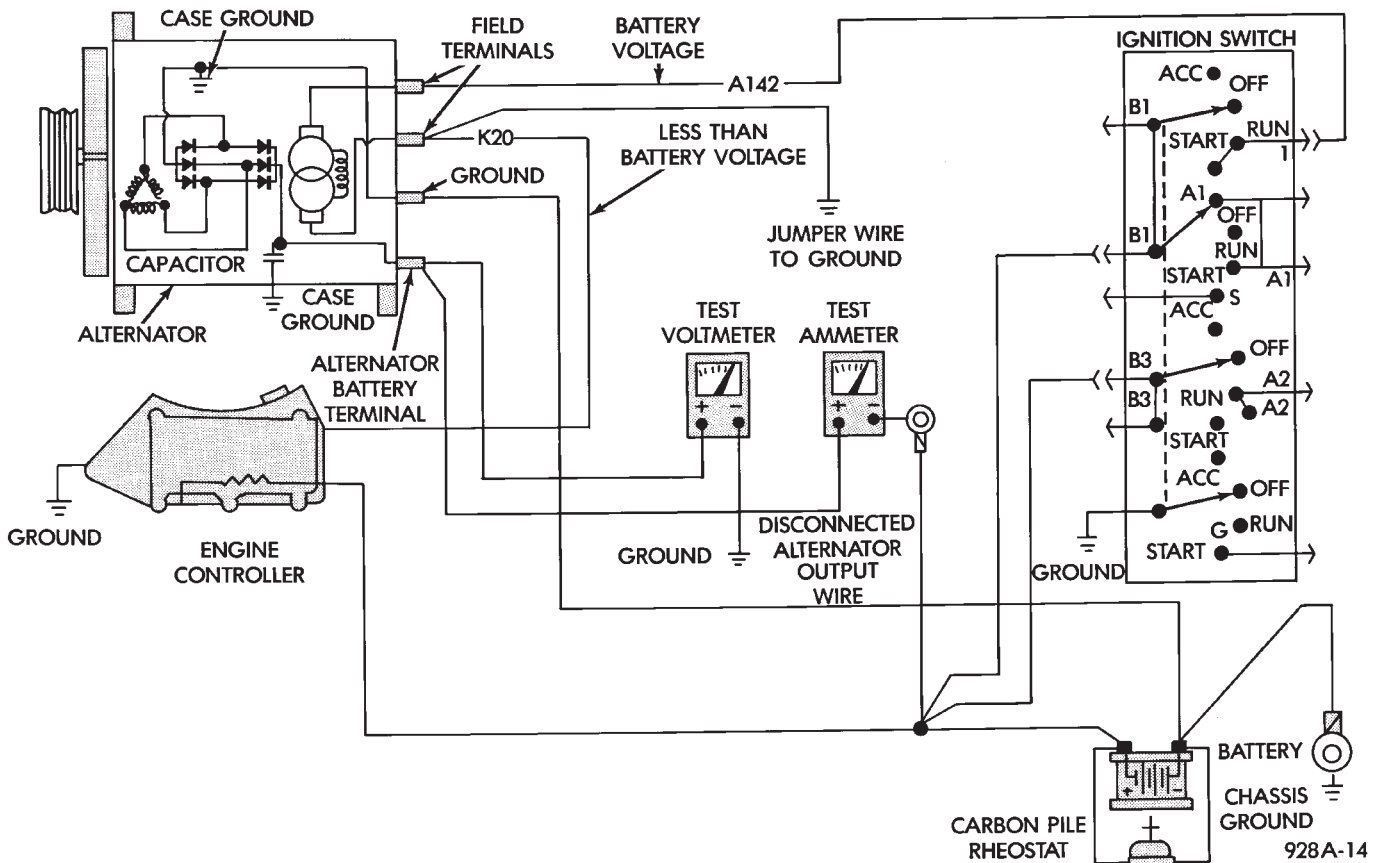

Fig. 4 Alternator Current Output Test

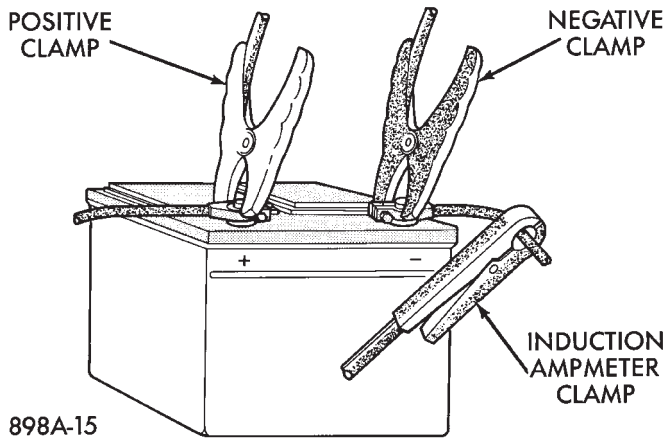

Fig. 5 Volt/Amp Tester Connections

(9) Full field the alternator. Connect a jumper wire between a good ground and to the K20 circuit terminal at the back of the alternator (Figs. 1 and 4).

CAUTION: Do not connect the A142 circuit terminal (Fig. 1) to ground the Fusible link will burn.

TEST

- (1) Start the engine. Immediately after starting, reduce engine speed to idle.
- (2) Adjust the carbon pile and engine speed in steps until an engine speed of 1250 rpm, and a voltmeter reading of 15 volts is obtained.

CAUTION: Do not allow the battery voltage to exceed 16 volts.

(3) The alternator amperage must meet the output requirements for the particular alternator being tested. Refer to Alternator Specifications for alternator identification and amperage outputs.

RESULTS

- (1) If amperage reading is less than specified, and alternator output wire resistance is not excessive (found from the previous tests), alternator should be replaced. Refer to Alternator replacement in Group 8B, Battery/Starter/Alternator Service. These alternators are not intended to be disassembled for service. It must be replaced as an assembly.
- (2) After current output test is completed, reduce engine speed, turn off carbon pile, and turn off ignition switch.
- (3) Disconnect battery negative cable.
- (4) Remove test ammeter, voltmeter, tachometer and carbon pile.
- (5) Remove jumper wire between K20 circuit terminal and ground.
- (6) Connect output wire to B+ terminal.
- (7) Connect negative battery cable.
- (8) Connect fresh air hose between Engine Controller and air cleaner if removed.

FAULT CODES—ON BOARD DIAGNOSTICS

INDEX

	page		page
Diagnostic Testing Using Fault Codes	19	General Description/Information	18
Drb II Diagnostic Tester	22		

GENERAL DESCRIPTION/INFORMATION

Another way of diagnosing charging system problems can be accomplished using the On-Board Diagnostic System Fault Codes.

A Fault Code shows a potential problem in a monitored circuit,

or a condition caused by a faulty component. A Fault Code can be retrieved by turning the ignition switch ON-OFF-ON-OFF-ON without starting the engine, and counting the possible number of flashes of the CHECK ENGINE LAMP in the instrument cluster.

EXAMPLES:

- If the Check Engine Lamp flashes four times, pauses, and flashes one more time, a Code 41 is shown. The first set of four flashes indicates the number four. The second set of one flash indicates one.
- If the Check Engine Lamp flashes four times, pauses, and flashes six more times, a Code 46 is shown. The first set of four flashes indicates the number four. The second set of six flashes indicates six.
- If the Check Engine Lamp flashes four times, pauses, and flashes seven more times, a Code 47 is

indicated. The first set of four flashes indicates the number four. The second set of seven flashes indicates seven.

ENGINE CONTROLLER

The Engine Controller is equipped with On-Board Diagnostic features and monitors all engine control circuits during a run/drive period. If a circuit or system does not perform properly, the Engine Controller will file in memory a predetermined Fault Code. This can

ignition switch ON/RUN cycles, the memory will be erased if the fault does not reoccur.

The Engine Controller is located in the engine compartment outboard of the battery (Fig. 6).

16 Refer to Fig. 7 Alternator Fault Code chart for relationships of alternator/charging system Fault Code numbers.

DIAGNOSTIC TESTING USING FAULT CODES

For diagnostic testing when using the fault codes, refer to Fig. 8 through 12.

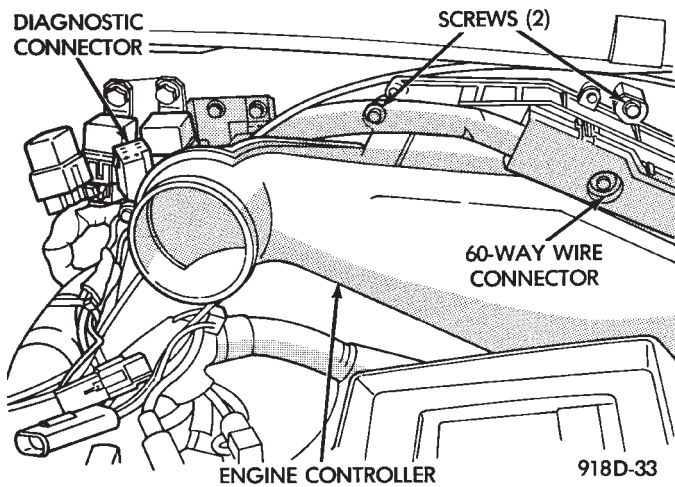

Fig. 6 Engine Controller and Diagnostic Connector

be used to help in diagnosing a problem. After 50 to 100

Fault Code	Type	Check Engine Lamp	Circuit	When Monitored By The Logic Module	When Put Into Memory
12	Indication	No	Battery Feed to the Logic Module Controller	All the time when the ignition switch is on.	If the battery feed to the logic module has been disconnected within the last 50-100 engine starts.
41	Fault	Yes	Alternator Field Control (Charging System)	All the time when the ignition switch is on.	Engine Controller computer output for alternator field does not respond to the voltage regulator control signal.
46	Fault	Yes	Battery Voltage Sensing (Charging System)	All the time when the engine is running.	If the battery sense voltage is more than 1 volt above the desired control voltage for more than 20 seconds.
47	Fault	Yes	Battery Voltage Sensing (Charging System)	Engine rpm above 1,500 rpm.	If the battery sense voltage is less than 1 volt below the desired control voltage for more than 20 seconds and active test indicates an alternator problem.
55	Indication	No			Indicates end of diagnostic mode.

918A-12

Fig. 7 ALTERNATOR FAULT CODES

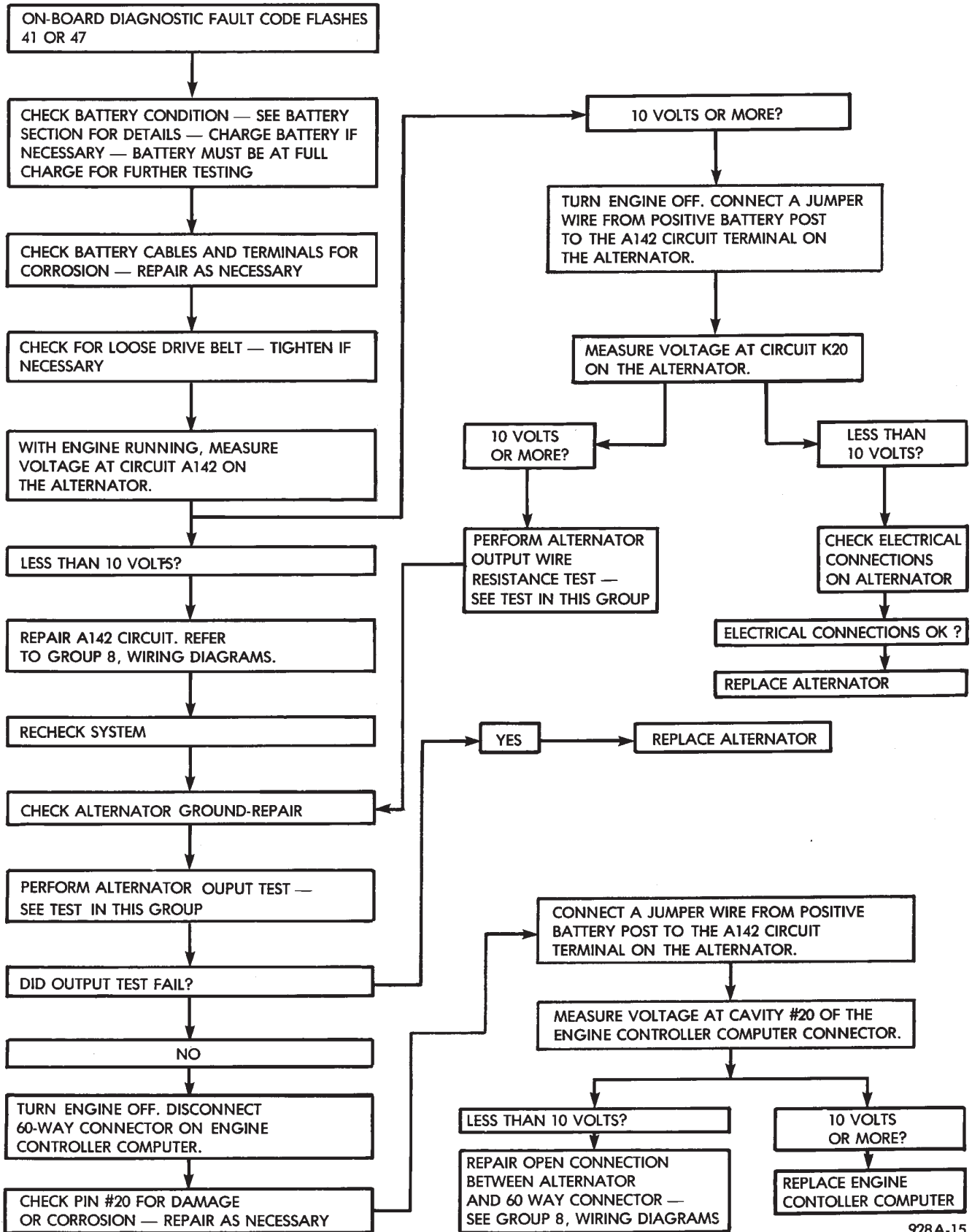

928A-15

Fig. 8 CHECK FOR INADEQUATE/LOW CHARGING—USING ON BOARD DIAGNOSTIC FAULT CODES

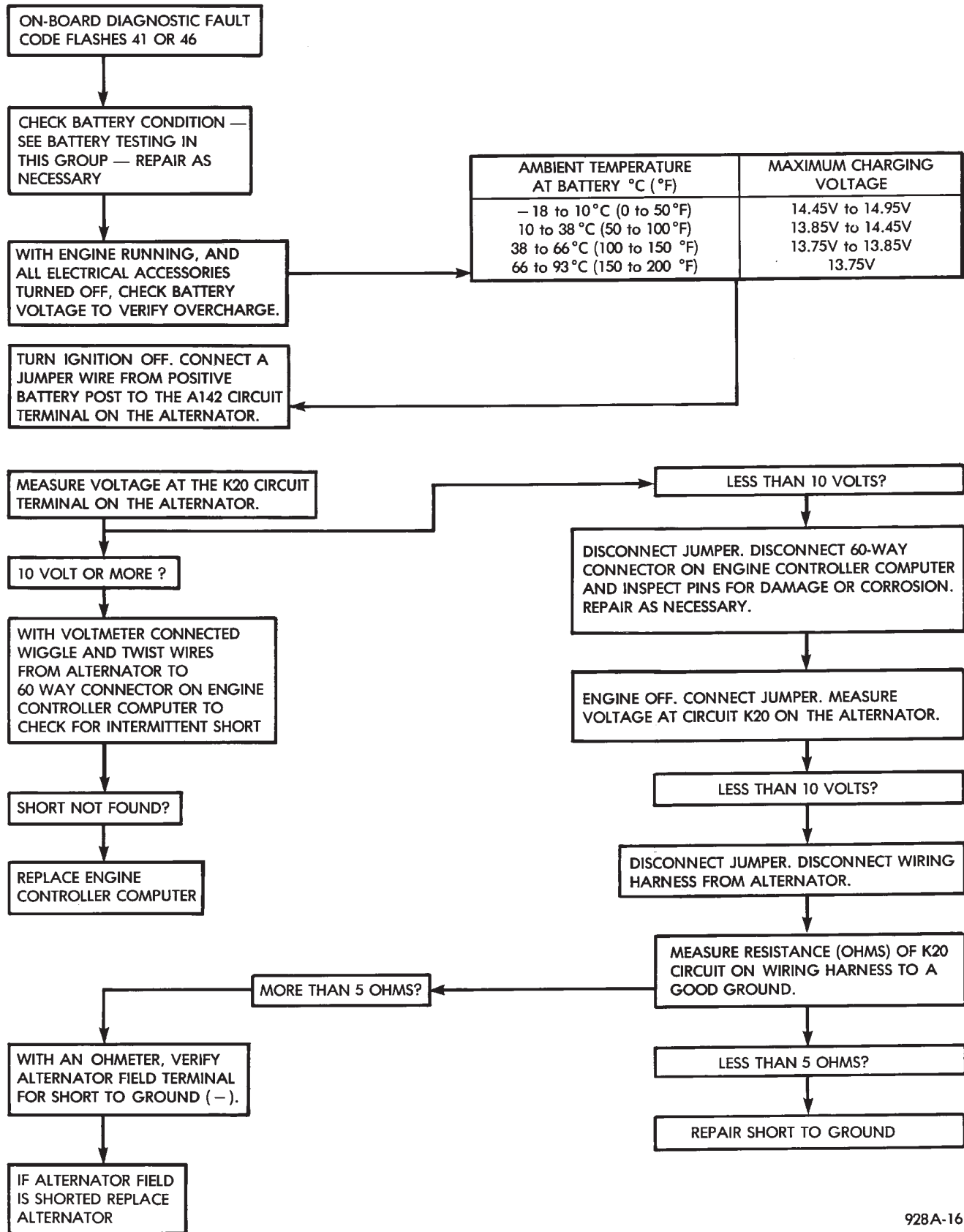

928A-16

Fig. 9 CHECK FOR OVERCHARGING—USING ON BOARD DIAGNOSTIC FAULT CODES

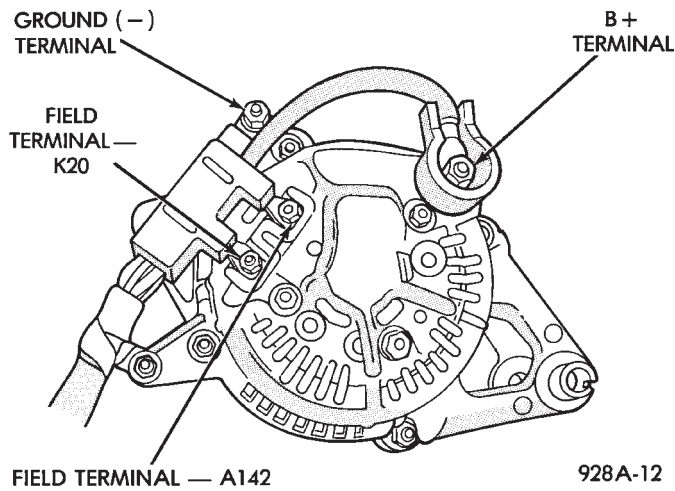

Fig. 10 Alternator Wiring Connections

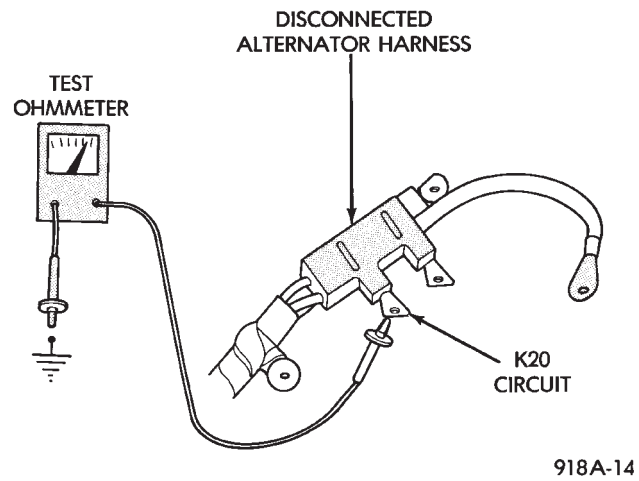

Fig. 12 Electrical Resistance Test

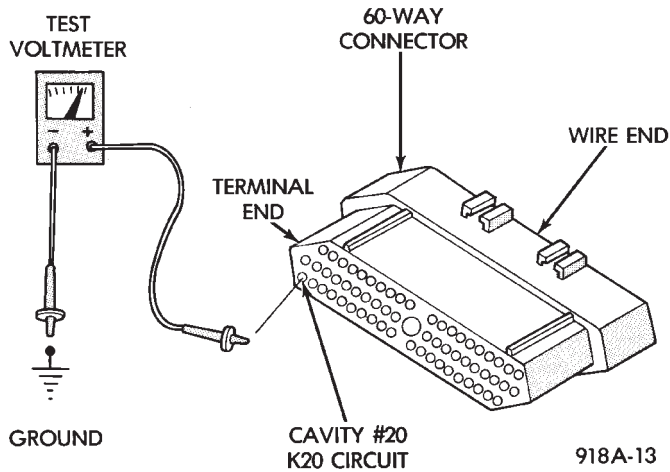

Fig. 11 Engine Controller Connector

DRB II DIAGNOSTIC TESTER

TESTING FAULT CODES

A more accurate device to retrieve fault codes is Diagnostic Tool (DRB II). This diagnostic tool, plugged into the diagnostic connector (Fig. 6) located near the battery, will display fault descriptions. The DRB II can also test various circuits and component functions. Refer to the instructions provided with the (DRB II) tool being used. Descriptions of Fault Codes for other vehicle systems can be found in the General Diagnosis section of Group 14, Fuel System.

SPECIFICATIONS

SPECIFICATIONS—STARTER/BATTERY

STARTER				
Manufacturer	Nippondenso		Bosch	
Engine Application	3.0L/3.8L	3.3L	3.0L	2.2-2.5L
Part Number and Power Rating	1.4 Kw	1.2 Kw	1.1 Kw	1.1 Kw
Voltage	12	12	12	12
No. of Fields	4	4	Permanent Magnet	
No. of Poles	4	4	6	6
Brushes	4	4	4	4
Drive	Conventional Gear Train	Conventional Gear Train	Planetary Gear Train	Planetary Gear Train
Free Running Test				
Voltage	11	11	11	11
Amperage Draw	73 Amps	73 Amps	73 Amps	69 Amps
Minimum Speed RPM	3601 RPM	3401 RPM	3473 RPM	3447 RPM
Solenoid Closing Voltage	7.5 Volts	7.5 Volts	7.5 Volts	7.5 Volts
Cranking Amperage Draw Test	150-220 Amps*	150-200 Amps*	150-220 Amps*	

*Engine should be up to operating temperature. Extremely heavy oil or tight engine will increase starter amperage draw.

BATTERY		
Load Test (Amps)	Cold Cranking Rating @ 0°F	Reserve Capacity
200 Amp	500 Amp	110 Minutes
250 Amp	600 Amp	120 Minutes
315 Amp	685 Amp	125 Minutes

CRANKING RATING is the current a battery can deliver for 30 seconds and maintain a terminal voltage of 7.2 volts or greater at specified temperature.
RESERVE CAPACITY RATING is the length of time a battery can deliver 25 amps and maintain a minimum terminal voltage of 10.5 volts at 27°C (80°F).

928A-10

SPECIFICATIONS—ALTERNATOR AMPERAGE/IDENTIFICATION NUMBERS

TYPE	**CASE I.D. TAG NUMBER	PULLEY GROOVES	ENGINE USAGE	*AMPERAGE OUTPUT
BOSCH 90 HS	4557431	4	2.5L	84 AMP
DENSO 90 HS	5234031	4	2.5L	86 AMP
DENSO 90 HS	5234032	6	3.0L-3.3L	90 AMP
DENSO 120 HS	5234208	4	2.5L	98 AMP
DENSO 120 HS	5234033	6	3.0L-3.3L	102 AMP

*WITH ALTERNATOR FULL FIELDING AT 1250 RPM

**CASE I.D. TAG NUMBER IS LOCATED ON BOTTOM OF ALTERNATOR CASE

928B-3



SPECIFICATIONS—ALTERNATOR OUTPUT
VOLTAGE

AMBIENT TEMPERATURE AT BATTERY °C	MAXIMUM CHARGING VOLTAGE
- 18 to 10°C	14.45 V to 14.95 V
10 to 38°C	13.85 V to 14.45 V
38 to 66°C	13.75 V to 13.85 V
66 to 93°C	13.75 V

918A-15

TORQUE SPECIFICATIONS

Description	Torque
Alternator Mounting Bolts	
2.2L/2.5L Engine	54 N•m (40 ft. lbs.)
3.3L/3.8L Engine	54 N•m (40 ft. lbs.)
3.0L Engine—Upper Bolt	54 N•m (40 ft. lbs.)
Lower Bolt	54 N•m (40 ft. lbs.)
Alternator Field Terminal	
Nuts	3 N•m (25 in. lbs.)
Alternator B+ Terminal and	
Ground Terminal Nuts	9 N•m (75 in. lbs.)
Battery Hold Down Clamp Bolt	14 N•m (125 in. lbs.)
Starter Mounting Bolts/Nuts	54 N•m (40 ft. lbs.)

928B-2