

# INSTRUMENT PANEL AND GAUGES

## CONTENTS

	page		page
ACCESSORY SWITCH CARRIER .....	12	INSTRUMENT PANEL REPLACEMENT .....	17
ACCESSORY SWITCH CARRIER REPLACEMENT .....	14	LOWER RIGHT INSTRUMENT PANEL REPLACEMENT .....	16
ACCESSORY SWITCH CARRIER TEST .....	14	REAR WIPER/WASHER CONTROL POD SWITCH REPLACEMENT .....	12
CLUSTER AND GAUGE SERVICE .....	2	SWITCH AND PANEL COMPONENT SERVICE ..	12
GAUGES .....	7	WARNING LAMP SYSTEM TESTS .....	10
GENERAL INFORMATION .....	1		

### GENERAL INFORMATION

#### INSTRUMENT CLUSTERS

The mechanical cluster is an electronic cluster with analog displays. The body computer sends the mechanical cluster the gauge readings and warning messages over the CCD Bus.

The electronic cluster receives most information displayed from the body and engine controller via the Chrysler Collision Detection (CCD) Serial Data Bus. The odometer memory is no longer retained in the cluster it is retained in the body controller.

The mechanical cluster without tachometer (Fig. 1) includes a 160 km/h (100 mph) speedometer, trip odometer, fuel, temperature gauges and warning indicators. The warning lamps include: low fuel, check gauges, door ajar, low washer fluid, check engine, gate ajar, volt and low oil pressure.

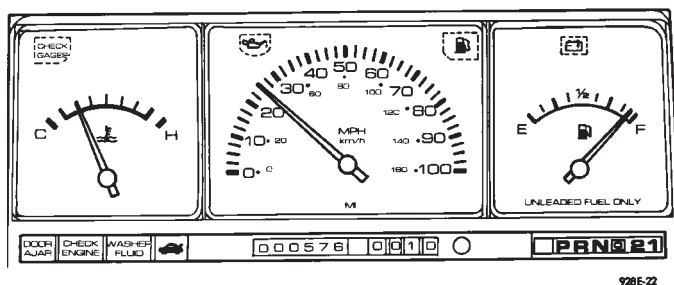
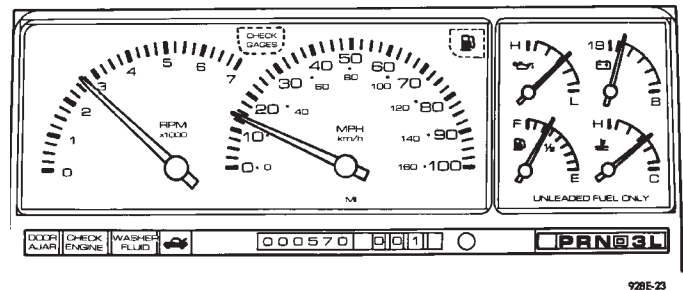

**Fig. 1 Mechanical Cluster Without Tachometer**

The mechanical cluster with tachometer (Fig. 2) will include a 160 km/h (100 mph) speedometer, trip odometer, gauges for fuel level, coolant temperature, oil pressure, and charging system voltage. Also, included is a 7,000 rpm tachometer. The warning lamps may include: low fuel, check gauges, door ajar, low washer fluid, check engine and gate ajar.

The electronic cluster (Fig. 3) contains:

- Digital speedometer and odometer
- Analog bar type gauges for, oil pressure, temperature, voltage, tachometer and fuel



**Fig. 2 Mechanical Cluster With Tachometer**

- Vehicle graphic showing door ajar, lift gate ajar and low washer fluid

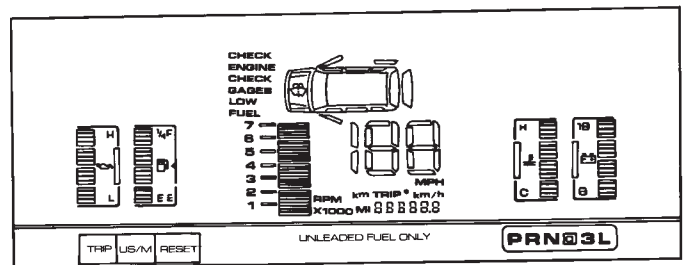

**Fig. 3 Electronic Cluster**

#### MAGNETIC GAUGES

All the gauges on instrument clusters are the magnetic type gauges. When the ignition switch is in the OFF position each gauge should rest at or below the low graduation.

#### ELECTRONIC DIGITAL CLOCK

The electronic digital clock is in the radio. The clock and radio each use the display panel built into the radio. A digital readout shows the time in hours and minutes whenever the ignition switch is in the ON or ACC position.

When the ignition switch is in the OFF position, or when the radio frequency is being displayed, time keeping is accurately maintained.

The procedure for setting the clock varies slightly with each radio. The correct procedure is described under the individual radio operating instructions referred to in the owner's manual supplied with the vehicle.

**MAINTENANCE REQUIRED REMINDER**

This system is designed to act as a reminder that scheduled vehicle emissions maintenance should be performed. The lamp is located in the Message Center. It is not intended to show a warning or that a state of emergency exists which or must be corrected to insure safe vehicle operation. The components covered by the system include the EGR system, PCV valve, and Oxygen sensor.

For further information, refer to Group 25, Emissions.

**SEAT BELT WARNING SYSTEM**

For testing of this system refer to Group 8U, Chime Warning/Reminder system.

**SEAT BELT WARNING LAMP**

The seat belt warning lamp is located in the warning indicator module assembly. Refer to Warning Indicator Module Assembly Lamp Replacement for lamp replacement.

**CLUSTER AND GAUGE SERVICE**

**CAUTION:** Disconnect battery cable, before servicing instrument panel. When power is required for test purposes, reconnect battery cable for test only.

Disconnect battery cable after test and before continuing service procedures.

Refer to Fig. 4 for cluster connector wire call out.

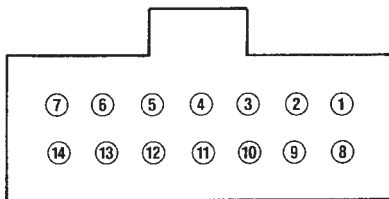

**VIEW FROM WIRE END**

CLUSTER CONNECTOR			
1	NO CONNECTION	8	LOW OIL SWITCH
2	BATTERY	9	BUS (-)
3	DECODE 1	10	BUS (+)
4	NO PIN	11	IGNITION
5	DECODE 2	12	NO CONNECTION
6	ILLUMINATION	13	NO CONNECTION
7	GROUND	14	GROUND ILLUMINATION

918E-74

**Fig. 4 Cluster Connector**

**MECHANICAL CLUSTER SERVICE**

To test the gauges and mechanical cluster a DBR II will be needed, and the Body Diagnostic Procedures Manual.

**ELECTRONIC CLUSTER SERVICE**

Refer to Body Diagnostic Procedures Manual when using DRB II.

**SELF DIAGNOSTIC SYSTEM**

The electronic cluster has an internal diagnostic routing to isolate problems within the cluster.

Perform cluster Self-Diagnostic Test to decide whether problem is within cluster or outside of cluster. Start test by depressing and holding Trip and Trip Reset buttons while turning the ignition switch ON, CHEC will appear in the odometer. Depressing the US/M switch will perform the next test. Refer to Fig. 5 and 6.

Successful completion of the SELF-DIAGNOSTIC TEST shows that the problem is in the wiring, connectors or sensors out side of the cluster.

**CONDITION: MECHANICAL CLUSTER IS NOT FUNCTIONAL WITH ENGINE RUNNING**

The cluster is indicating that it is not receiving any CCD Bus messages if:

- Check gauge lamp is ON.
- Tachometer, speedometer and gauges are at low scale.
- Check Bus wiring going to the cluster and body computer.

**WARNING INDICATOR MODULE REPLACEMENT OR LAMP REPLACEMENT**

- (1) Remove warning indicator grille by prying up with a flat blade tool (Fig. 7).
- (2) Remove three mounting screws from the warning indicator module assembly.
- (3) Replace one piece lamp and socket. The lamp cannot be separated from the socket.
- (4) For installation reverse above procedures.

**INSTRUMENT PANEL CLUSTER BEZEL REPLACEMENT**

- (1) Remove warning indicator grille by prying up with a flat blade tool.
- (2) Remove three mounting screws from the warning indicator module assembly and disconnect wire connector.
- (3) Remove steering column cover (Fig. 8). Set parking brake and shift gear sector into low.
- (4) Remove instrument cluster bezel five screws and remove bezel. Disconnect POD switch wire connectors (Fig. 9).
- (5) Remove POD switches by unsnapping from the back side of the cluster bezel.
- (6) For installation reverse above procedures.

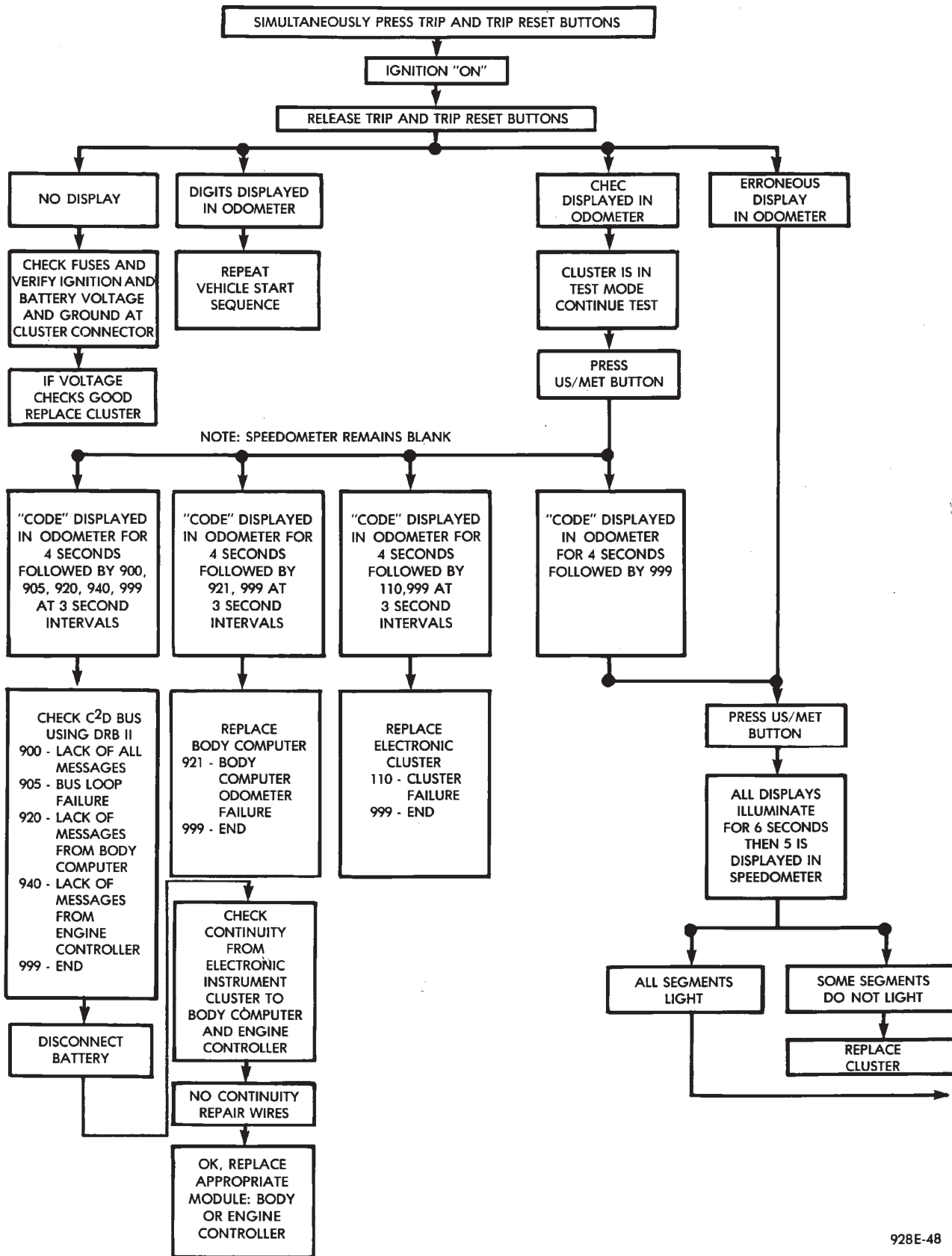

928E-48

Fig. 5 Electronic Cluster Self-Diagnostic Test

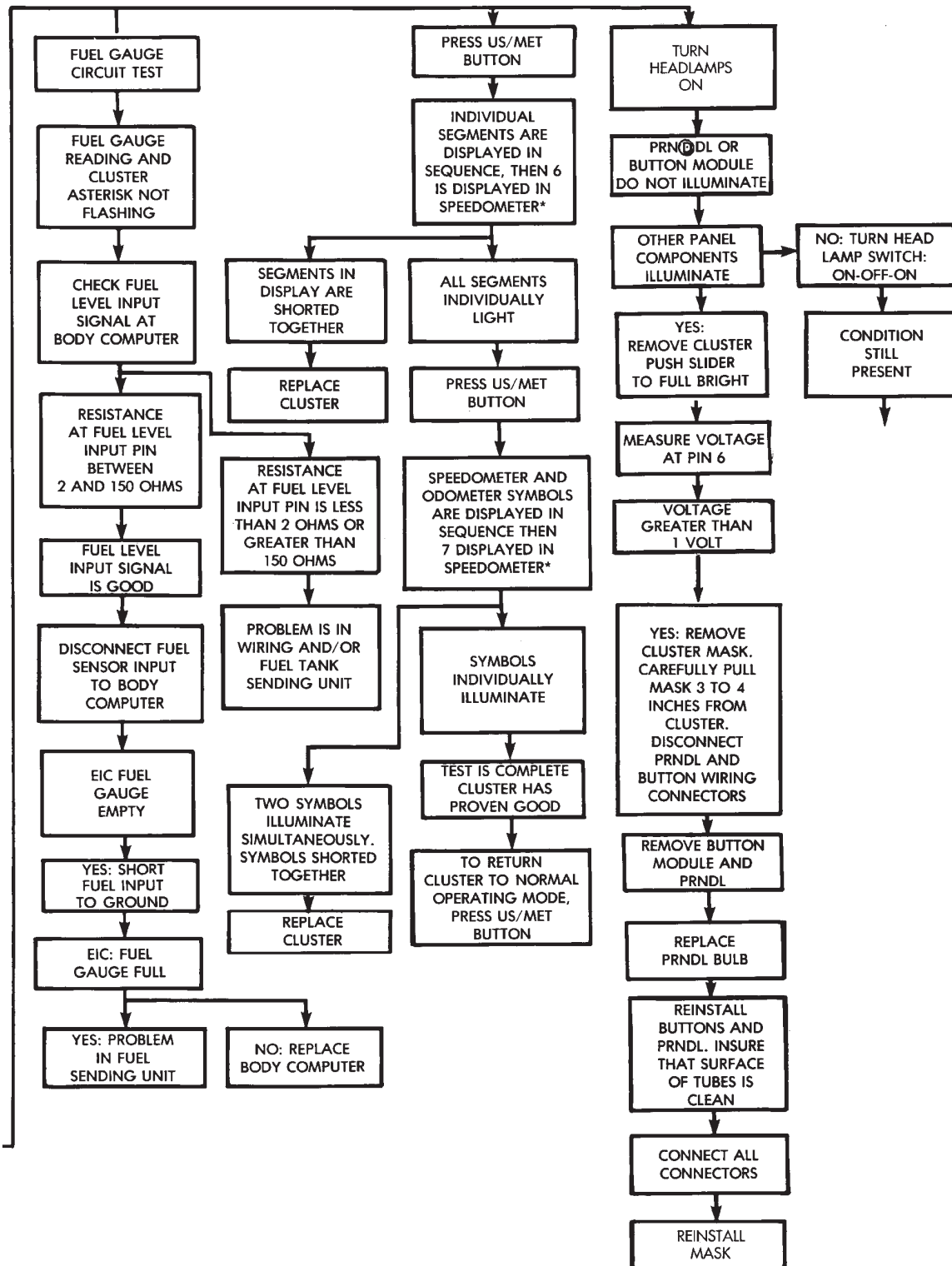
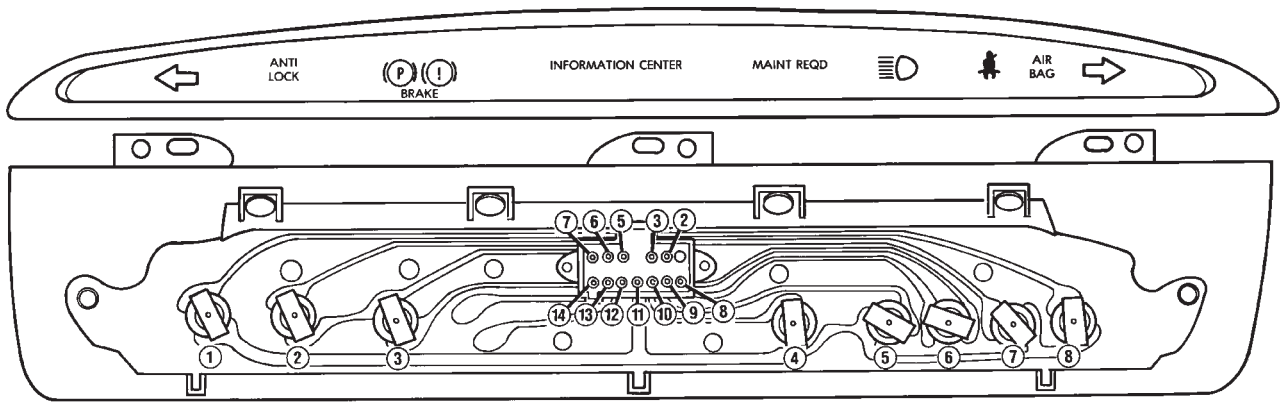

Fig. 6 Electronic Cluster Self-Diagnostic Test—Continued



LAMPS	
1	LEFT TURN SIGNAL
2	ANTI-LOCK
3	BRAKE
4	MAINTENANCE REQUIRED
5	HI BEAM
6	SEAT BELT
7	AIRBAG
8	RIGHT TURN SIGNAL

CONNECTOR	
2	AIRBAG
3	RIGHT TURN SIGNAL
5	LEFT TURN SIGNAL
6	ANTI-LOCK
7	IGNITION
8	SEAT BELT
9	HI BEAM
10	MAINTENANCE REQUIRED
11	GROUND
12	
13	
14	BRAKE

918E-70

**Fig. 7 Warning Indicator Module**

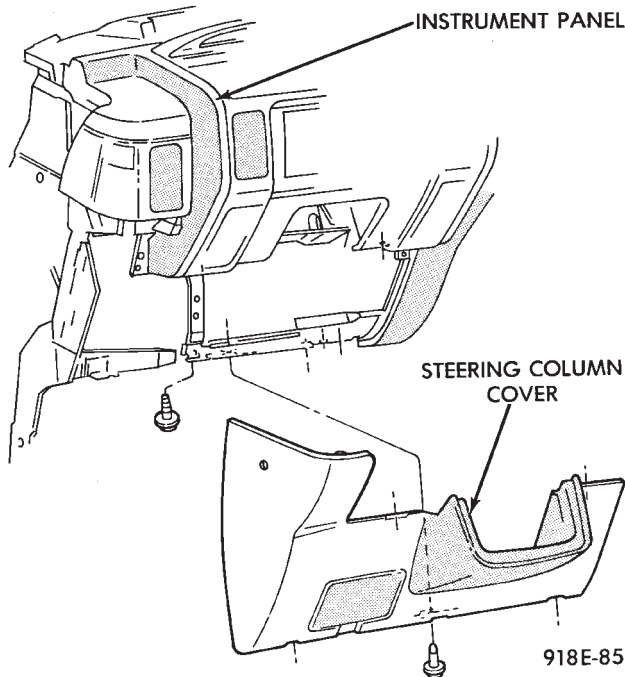

918E-85

**Fig. 8 Instrument Panel Steering Column Cover**

**INSTRUMENT PANEL CLUSTER LENS REPLACEMENT**

(1) Remove warning indicator grille by prying up with a flat blade tool. (2) Remove three mounting screws from the warning indicator module assembly and disconnect wire connector.

(3) Remove steering column cover (Fig. 8). Set parking brake and shift gear selector into low.

(4) Remove cluster bezel and disconnect wire connectors.

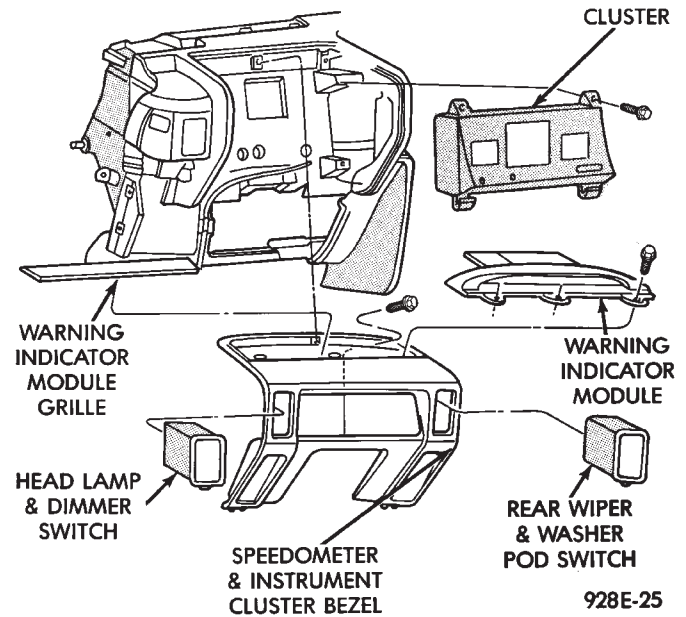

928E-25

**Fig. 9 Instrument Cluster Bezel**

(5) Remove six screws securing lens to cluster housing (Fig. 10).

(6) Remove lens.

(7) For installation reverse above procedures.

**INSTRUMENT PANEL CLUSTER REPLACEMENT**

(1) Remove warning indicator grille by prying up with a flat blade tool.

(2) Remove three mounting screws from the warning indicator module assembly and disconnect wire connector.



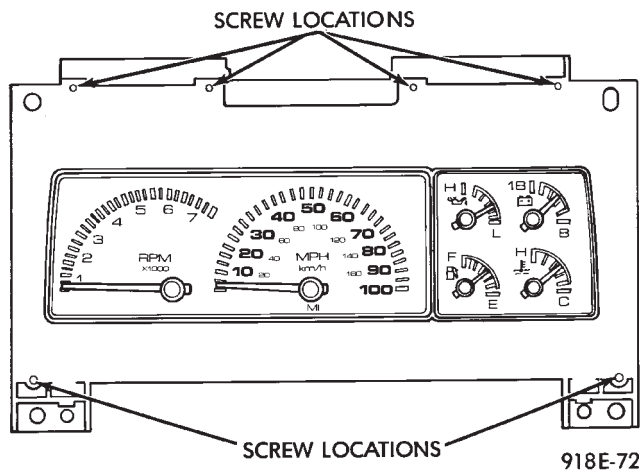
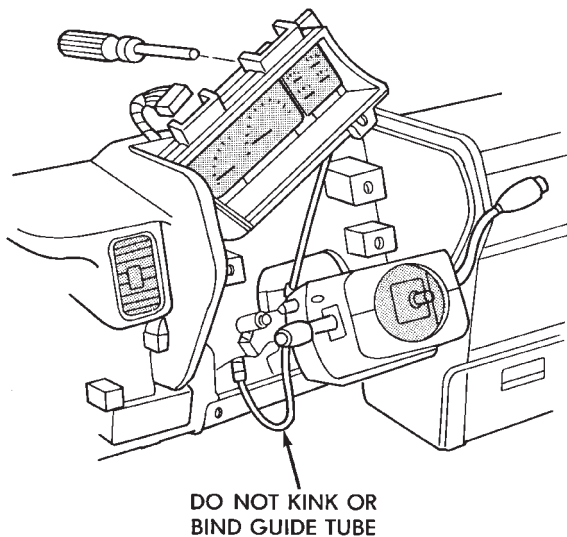

**Fig. 10 Cluster Lens**

(3) Remove steering column cover (Fig. 8). Set parking brake and shift gear selector into low.

(4) Remove cluster bezel and disconnect wire connectors.

(5) Remove four screws securing cluster. Carefully rotate cluster and disconnect connector, to access PRNDL attaching screws. Remove two screws attaching PRNDL to cluster (Fig. 11).



STEERING WHEEL REMOVED FOR CLARITY 918E-92

**Fig. 11 Removal of PRNDL**

(6) For electronic instrument cluster if equipped:

(a) Remove four screws securing cluster.

(b) Remove four screws attaching mask to housing.

(c) Rotate mask down then disconnect buttons and PRNDL.

(d) Remove two screws attaching PRNDL to mask on electronic instrument cluster only.

(7) Remove cluster.

(8) For installation reverse above procedures.

• When installing cluster, do not kink or bind PRNDL

guide tube and position guide tube in original location.

• Move shift lever to Neutral (N) and note pointer location. Move shift lever to D, L and P note pointer location. Adjust, if necessary to center pointer on N. Refer to Fig. 12 for adjusting procedure.

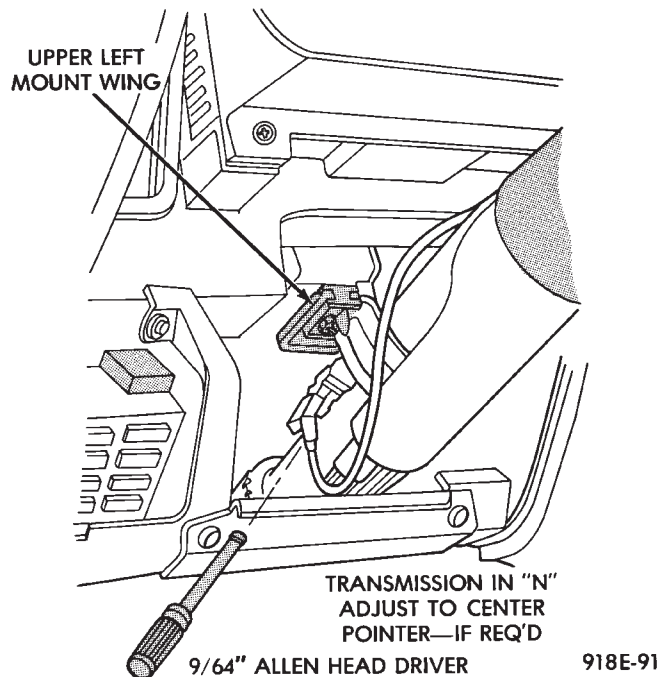

**Fig. 12 Adjusting PRNDL**

#### CLUSTER PRINTED CIRCUIT BOARD REPLACEMENT

(1) Remove warning indicator grille by prying up with a flat blade tool.

(2) Remove three mounting screws from the warning indicator module assembly and disconnect wire connector.

(3) Remove steering column cover (Fig. 8). Set parking brake and shift gear selector into low.

(4) Remove cluster bezel and disconnect POD switch wire connectors.

(5) Remove four screws securing cluster. Carefully rotate cluster and disconnect connector, to access PRNDL attaching screws. Remove two screws attaching PRNDL to cluster (Fig. 11).

(6) Remove cluster.

(7) Remove six screws and attach cover (Fig. 13).

(8) Disconnect odometer connector and remove screw attaching printed circuit board and housing.

(9) For installation reverse above procedures.

• When installing cluster, do not kink or bind PRNDL guide tube and position guide tube in original location.

• Move shift lever to Neutral (N) and note pointer location. Move shift lever to D, L and P note pointer location. Adjust, if necessary to center pointer on N. Refer to Fig. 12 for adjusting procedure.

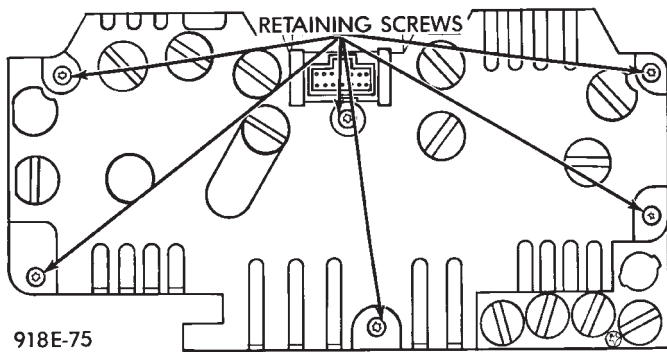

918E-75

**Fig. 13 Printed Circuit Board**

**CLUSTER LAMPS BULB REPLACEMENT  
MECHANICAL CLUSTER ONLY**

- (1) Remove warning indicator grille by prying up with a flat blade tool.
- (2) Remove three mounting screws from the warning indicator module assembly and disconnect wire connector.
- (3) Remove steering column cover (Fig. 8). Set parking brake and shift gear selector into low.
- (4) Remove cluster bezel and disconnect POD switch wire connectors.
- (5) Carefully roll cluster out of instrument panel without disconnecting PRNDL.
- (6) Remove one piece integral bulb and socket from rear of cluster (Fig. 14).

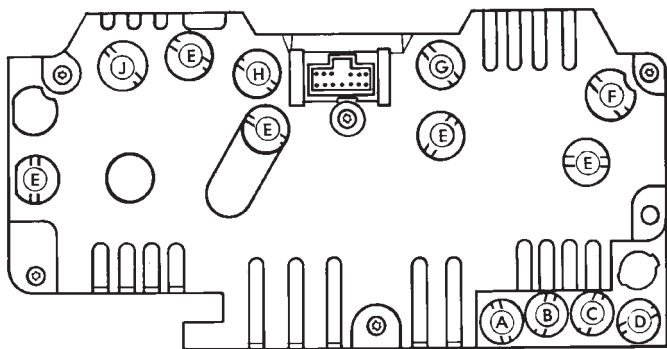

LAMP DESIGNATION			
A	GATE AJAR	F	CHECK GAUGES
B	WASHER FLUID	G	LOW OIL
C	CHECK ENGINE	H	LOW FUEL
D	DOOR AJAR	J	VOLT
E	ILLUMINATION		

918E-76

**Fig. 14 Mechanical Cluster Bulb Location**

- (7) For installation reverse above procedures.

**GAUGES**

To test the gauges and mechanical cluster a DRB II will be needed and Body Diagnostic Procedures Manual.

**It is not necessary to remove instrument cluster from vehicle for gauge replacement.**

**When removing gauge from cluster, gauge must be pulled straight out, without twisting or damage to gauge pins may result.**

**FUEL GAUGE REPLACEMENT**

- (1) Remove warning indicator grille by prying up with a flat blade tool.
- (2) Remove three mounting screws from the warning indicator module.
- (3) Remove steering column cover (Fig. 8). Set parking brake and shift gear selector into low.
- (4) Remove cluster bezel and disconnect POD switch wire connectors.
- (5) Remove cluster lens.
- (6) Remove six screws attaching gauge to cluster (Fig. 15 and 16).

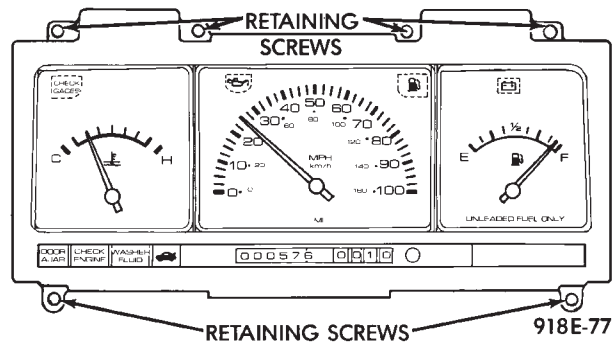

**Fig. 15 Gauge Assembly Without Tachometer**

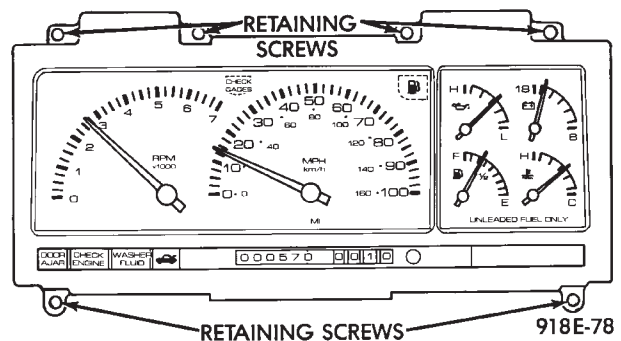

**Fig. 16 Gauge Assembly With Tachometer**

- (7) Remove fuel gauge.
- (8) For installation reverse above procedures.

**VOLTMETER REPLACEMENT**

- (1) Remove warning indicator grille by prying up with a flat blade tool.
- (2) Remove three mounting screws from the warning indicator module.

- (3) Remove steering column cover (Fig. 8). Set parking brake and shift gear selector into low.
- (4) Remove cluster bezel and disconnect POD switch wire connectors.
- (5) Remove cluster lens.
- (6) Remove six screws attaching gauge to cluster (Fig. 15 or 16).
- (7) Remove voltmeter gauge.
- (8) For installation reverse above procedures.

#### TEMPERATURE GAUGE REPLACEMENT

- (1) Remove warning indicator grille by prying up with a flat blade tool.
- (2) Remove three mounting screws from the warning indicator module.
- (3) Remove steering column cover (Fig. 8). Set parking brake and shift gear selector into low.
- (4) Remove cluster bezel and disconnect POD switch wire connectors.
- (5) Remove cluster lens.
- (6) Remove six screws attaching gauge to cluster (Fig. 15 or 16).
- (7) Remove temperature gauge.
- (8) For installation reverse above procedures.

#### OIL PRESSURE GAUGE REPLACEMENT

- (1) Remove warning indicator grille by prying up with a flat blade tool.
- (2) Remove three mounting screws from the warning indicator module.
- (3) Remove steering column cover (Fig. 8). Set parking brake and shift gear selector into low.
- (4) Remove cluster bezel and disconnect POD switch wire connectors.
- (5) Remove cluster lens.
- (6) Remove six screws attaching gauge to cluster (Fig. 15 or 16).
- (7) Remove oil pressure gauge.
- (8) For installation reverse above procedures.

#### TACHOMETER REPLACEMENT

- (1) Remove warning indicator grille by prying up with a flat blade tool.
- (2) Remove three mounting screws from the warning indicator module.
- (3) Remove steering column cover (Fig. 8). Set parking brake and shift gear selector into low.
- (4) Remove cluster bezel and disconnect POD switch wire connectors.
- (5) Remove cluster lens.
- (6) Remove six screws attaching gauge to cluster (Fig. 15 or 16).
- (7) Remove tachometer gauge.
- (8) For installation reverse above procedures.

#### SPEEDOMETER ASSEMBLY REPLACEMENT

- (1) Remove warning indicator grille by prying up with a flat blade tool.

- (2) Remove three mounting screws from the warning indicator module.
- (3) Remove steering column cover (Fig. 8). Set parking brake and shift gear selector into low.
- (4) Remove cluster bezel and disconnect POD switch wire connectors.
- (5) Remove cluster lens.
- (6) Remove six screws attaching gauge to cluster (Fig. 15 or 16).
- (7) Remove speedometer gauge.
- (8) For installation reverse above procedures.

#### ODOMETER ASSEMBLY REPLACEMENT

- (1) Remove warning indicator grille by prying up with a flat blade tool.
- (2) Remove three mounting screws from the warning indicator module.
- (3) Remove steering column cover (Fig. 8). Set parking brake and shift gear selector into low.
- (4) Remove cluster bezel and disconnect POD switch wire connectors.
- (5) Remove four screws securing cluster. Carefully rotate cluster and disconnect connector, to access PRNDL attaching screws. Remove two screws attaching PRNDL to cluster (Fig. 11).
- (6) Remove cluster.
- (7) Remove six screws that attach cover (Fig. 13).
- (8) Disconnect odometer motor connector on rear of cluster (Fig. 17).

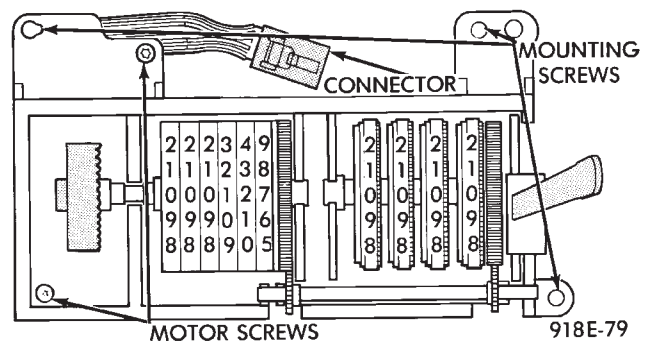
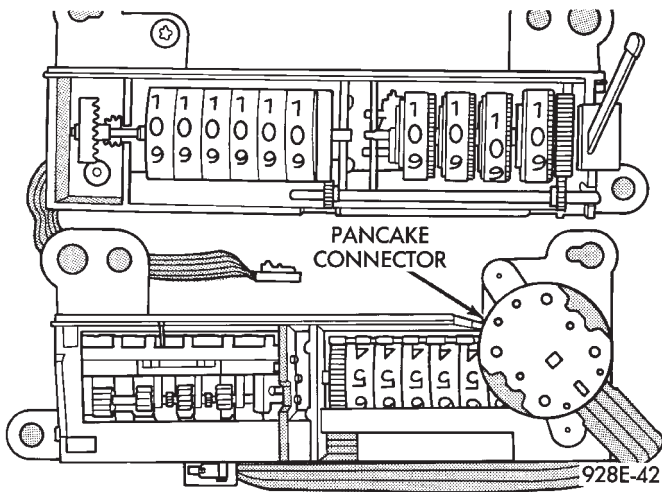

Fig. 17 Odometer

**CAUTION: Do Not disconnect pancake connector on back side of motor (Fig. 18).**

- (9) Remove lens.
  - (10) Remove screws attaching gauge to cluster.
  - (11) Remove three screws and odometer.
  - (12) For installation reverse above procedures.
- When installing cluster, do not kink or bind PRNDL guide tube and position guide tube in original location.
  - Move shift lever to Neutral (N) and note pointer location. Move shift lever to D, L and P note pointer location. Adjust, if necessary to center pointer on N. Refer to Fig. 12 for adjusting procedure.

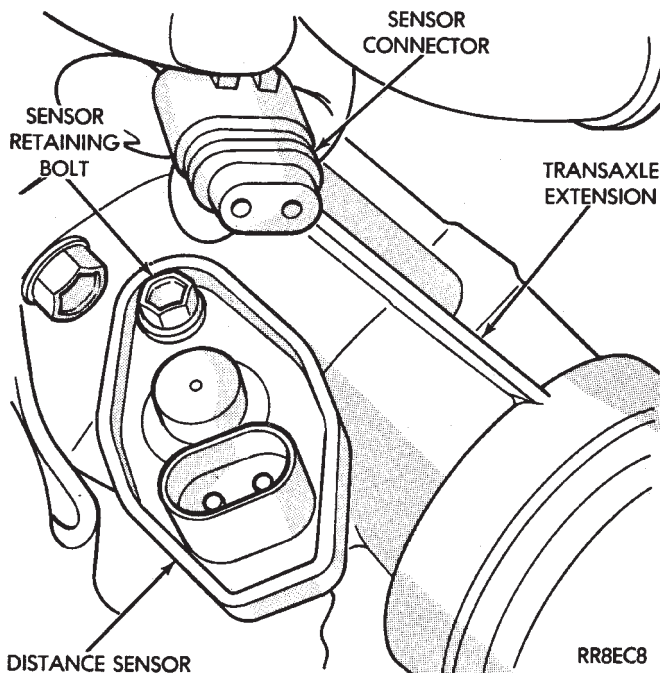



**Fig. 18 Odometer Motor and Connector**

**DISTANCE SENSOR REPLACEMENT**

(1) Remove harness connector from sensor and make sure the weather seal is on harness connector (Figs. 19 and 20).



**Fig. 19 Distance Sensor and Connector**

- (2) Remove sensor retaining bolt.
- (3) Pull sensor and pinion gear assembly out of transaxle. If necessary, carefully pry loose with a flat blade screwdriver.
- (4) Remove pinion gear from sensor.
- (5) For installation reverse above procedures. Seat sensor assembly by hand to insure proper gear engagement. Tighten retaining bolt to 7 N•m (60 in. lbs.).

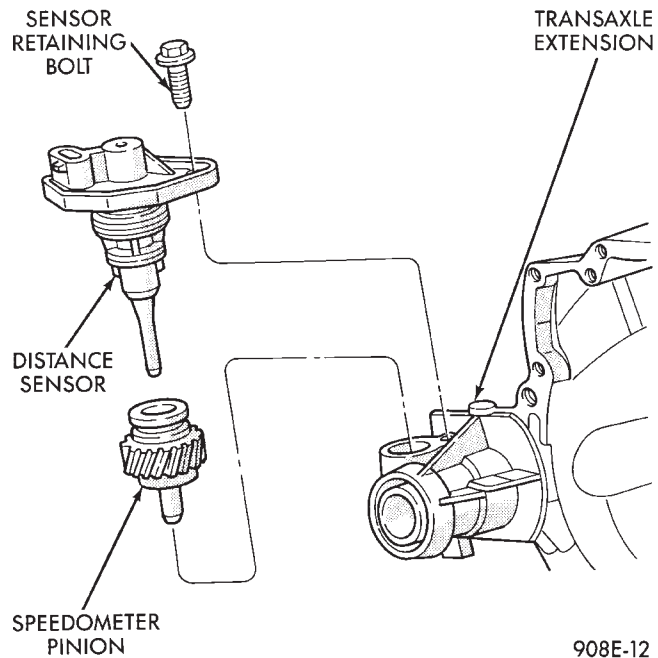

**Fig. 20 Distance Sensor and Speedometer Pinion**

**DISTANCE SENSOR TEST**

For testing of the distance sensor and related components, use DRB II and Body Diagnostic Procedures Manual.

**SENDING UNIT TEST**

When a problem occurs with a cluster gauge, before disassembling the cluster to check the gauge, check for a defective sending unit or wiring.

- (1) Sending units and wiring can be checked by grounding the connector leads, at the sending unit, in the vehicle.
- (2) With the ignition in the ON position, a grounded input will cause the fuel or temperature gauge to read at or above maximum.

**FUEL TANK SENDING UNIT TEST**

- (1) Disconnect wiring from fuel tank sending unit.
- (2) Connect wiring to a known good sending unit (Fig. 21).
- (3) Check fuel gauge as described in the following steps. Allow at least two minutes at each test point for gauge to settle.
  - (a) Move float arm of sending unit to its empty stop and turn ignition key to ON position. The gauge should read Empty or below.
  - (b) Move sending unit float arm to full stop. The gauge should read Full or above.

**CONDITION**

- (1) If fuel gauge does not meet specifications, check following items as possible causes:
  - (a) Wiring and connections between gauge sending unit and body computer.

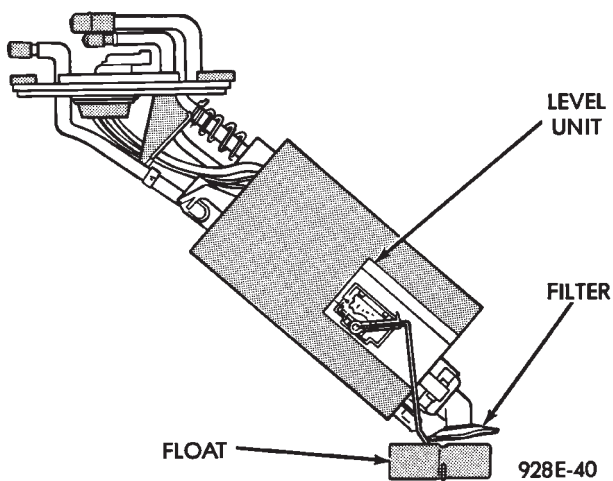

**Fig. 21 Fuel Pump Assembly (Typical)**

(b) Check for loose gauge adaptor nuts on the instrument cluster printed circuit board. Tighten gauge adapter nuts as necessary.

(c) If the body computer and printed circuit board check okay the fuel gauge is defective.

(2) If fuel gauge meets specifications check fuel tank and original fuel level assembly as follows:

(a) Carefully remove fuel level unit from tank.

(b) Refer to sending unit removal Group 14, Fuel.

(c) Connect sending unit wire as described in the test procedure.

(3) If fuel gauge now checks within specifications, original sending unit is electrically okay, check following as possible cause:

(a) Ground wire from sending unit to left side cowl for continuity.

(b) fuel level assembly is deformed. Make sure sending unit float arm moves freely.

(c) Fuel level assembly improperly installed, install properly.

(d) Mounting flange on fuel tank for fuel pump level assembly is deformed.

(e) Fuel tank bottom deformed causing improper positioning of fuel level assembly. Replace or repair tank and recheck sending unit.

## WARNING LAMP SYSTEM TESTS

All warning lamps come on when the ignition switch is first turn to the ON position. They will stay on for a few seconds to see if lamps are working.

### BRAKE SYSTEM WARNING LAMP TEST

The brake warning lamp illuminates when parking brake is applied with ignition key turned ON. The same light will also illuminate should one of the two service brake systems fail when brake pedal is applied. To test system turn ignition key ON and apply parking brake. If lamp fails to light, inspect for a burned out

bulb, disconnected socket, a broken or disconnected wire at switch. The lamp also lights when the ignition switch is turned to start.

To test service brake warning system, raise vehicle on a hoist and open a wheel cylinder bleeder while a helper depresses brake pedal and observes warning lamp. If lamp fails to light, inspect for a burned out bulb, disconnected socket, a broken or disconnected wire at switch (Fig. 22 and 23).

If lamp is not burned out and wire continuity is proven, replace brake warning switch. The switch is located in brake line Tee fitting mounted on frame rail in engine compartment below master cylinder (Fig. 23).

**CAUTION:** If wheel cylinder bleeder was opened check master cylinder fluid level.

### TEMPERATURE WARNING LAMP TEST

To test the temperature warning lamp, turn the ignition switch to the ON position. Disconnect the wire from the temperature switch on the engine and momentarily touch the wire to ground. When the wire is grounded the bulb of the indicator should illuminate. If the bulb fails to illuminate, indications are of a faulty circuit in the system, body computer is malfunctioning or possibly the indicator bulb is faulty. Repair or replace as necessary.

### LOW OIL PRESSURE WARNING LAMP TEST

The low oil pressure warning lamp will illuminate when the ignition key is turned to the ON position. The lamp also illuminates when the engine oil pressure drops below a safe oil pressure level.

To test the system, turn the ignition key to the ON position. If the lamp fails to light, inspect for broken or disconnected wires at the oil pressure combination unit located at the front of the engine (Figs. 24 and 25).

If the wire at the connector checks good, pull connector loose from the unit. With a jumper wire ground switch terminal in the connector to the engine. With the ignition key turned to the ON position, check the warning lamp. If lamp still fails to light, inspect for a burned out bulb or disconnected socket in the cluster.

### COMBINATION OIL SENDING UNIT TESTS

The combination oil unit has two functions (Figs. 24 and 25):

(1) The normally closed circuit keeps the oil pressure warning lamp on until there is oil pressure.

(2) The sending unit provides a resistance that varies with oil pressure.

(3) To test the normally closed oil lamp circuit, disconnect the locking connector and measure the resis-

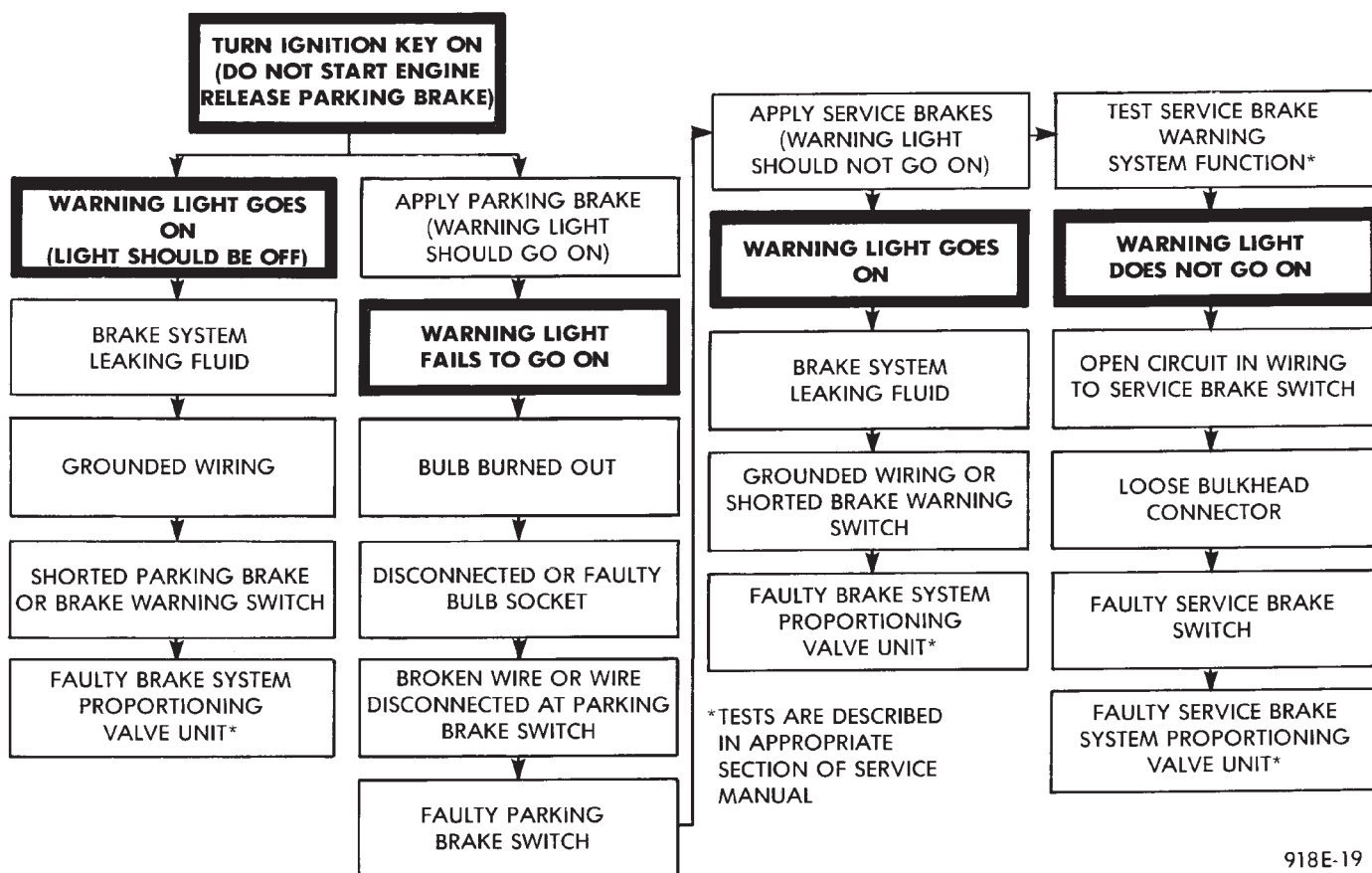

**Fig. 22 Brake System Warning Lamp Diagnosis**

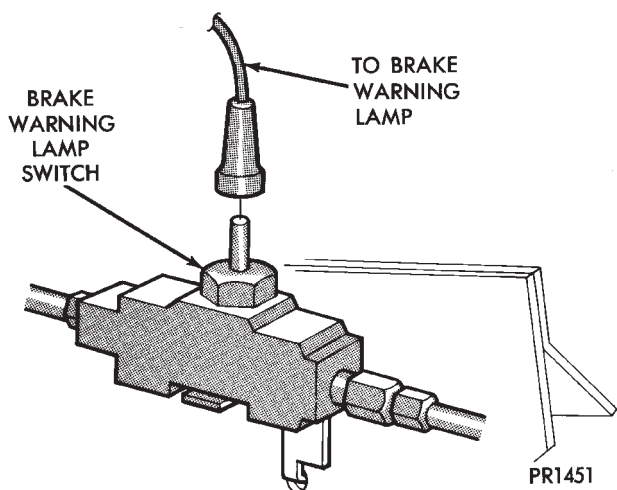
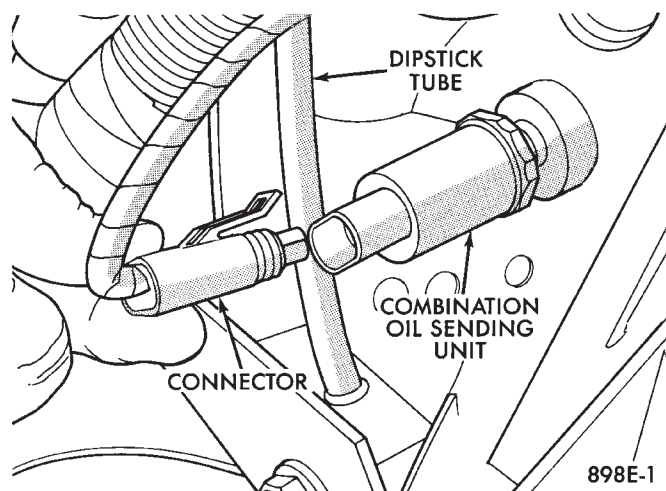

**Fig. 23 Brake Warning Lamp Switch**

tance between the switch terminal and the metal housing (Fig. 26). The ohmmeter should read zero ohms.

(4) Start the engine. If there is oil pressure, the ohmmeter should read an open circuit.

(5) To test the sending unit, measure the resistance between the sending unit terminal and the metal housing. The ohmmeter should read open.



**Fig. 24 Combination Oil Sending Unit**

(6) Start the engine. The ohmmeter should read between 30 and 55 ohms, depending on engine speed, oil temperature, and oil viscosity.

(7) If the above results are not obtained, replace the switch.

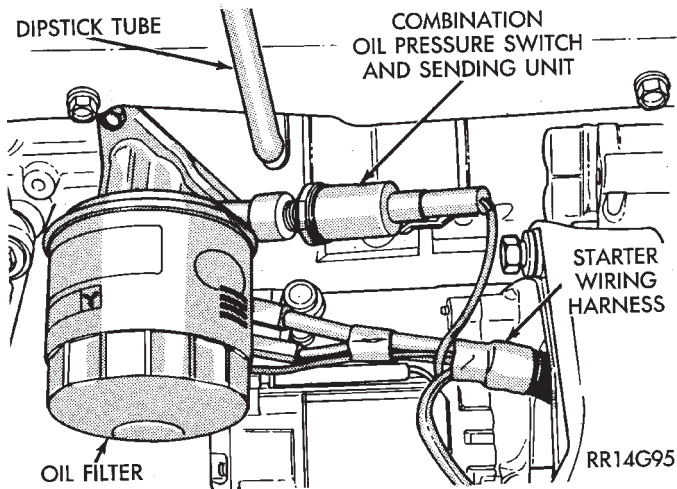
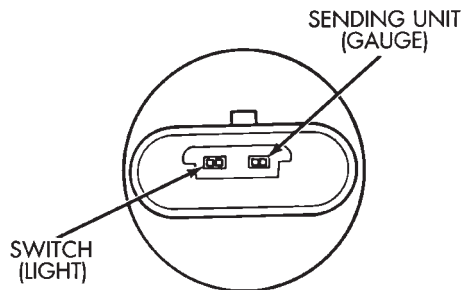

Fig. 25 Combination Oil Sending Unit—3.0L Engine



898E-2

Fig. 26 Combination Oil Sending Unit Terminals

## SWITCH AND PANEL COMPONENT SERVICE

### HEADLAMP SWITCH

The headlamp, parking lamp and hazard switches operate with a push-on, push-off action. The interior lamp/dimming control switch has a horizontal sliding action with five clearly defined detent positions. The parking/headlamp lamp switches latch ON and use a cross cancelling mechanism to ensure the two systems are not ON at once (Fig. 27).

### SWITCH TEST

- (1) Remove headlamp switch, refer to Switch/Lamp Replacement.
- (2) Using ohmmeter test continuity between terminals, refer to Fig. 28. If no continuity or not within limits, replace headlamp switch.

### SWITCH/LAMP REPLACEMENT

- (1) Remove warning indicator grille by prying up with a flat blade tool (Fig. 9).
- (2) Remove three mounting screws from the warning indicator module assembly.
- (3) Remove eight screws mounting the cluster bezel to the instrument panel.
- (4) Tilt column down if possible for ease.

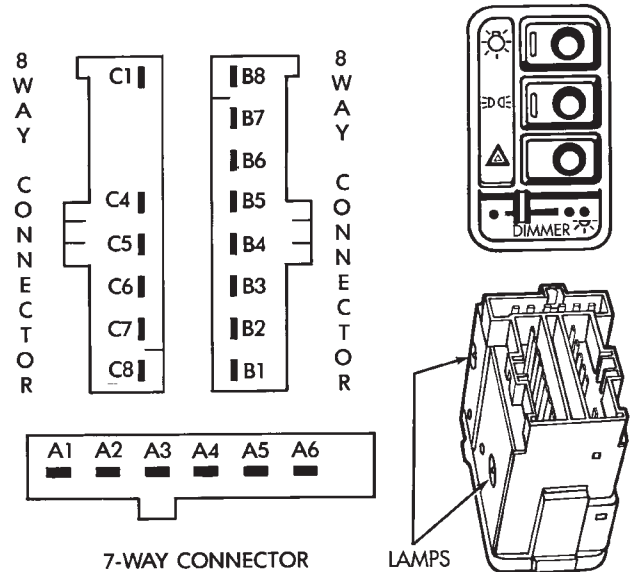

Fig. 27 Headlamp POD Switch

- (5) Gently pull cluster bezel out, to gain access to the switch assembly's snap fingers and push switch out through mounting hole for POD switch assembly (Fig. 27).

- (6) Remove wiring connectors for POD switch assembly.

- (7) For installation reverse above procedures. Verify the functions of the headlamp switch.

### REAR WIPER/WASHER CONTROL POD SWITCH REPLACEMENT

- (1) Remove warning indicator grille by prying up with a flat blade tool.
- (2) Remove three mounting screws from the warning indicator module assembly.
- (3) Remove eight screws mounting the cluster bezel to the instrument panel.
- (4) Tilt column down if possible for ease.
- (5) Gently pull cluster bezel out, to gain access to the switch assembly's snap fingers and push switch out through mounting hole for POD switch assembly (Fig. 29).
- (6) Remove wiring connectors for POD switch assembly.
- (7) For installation reverse above procedures. Verify the functions of the front and rear wipe/wash system.

### ACCESSORY SWITCH CARRIER

The accessory switch carrier consist of one or more of the following switches (Fig. 30).

- Liftgate release switch
- Rear window defogger switch
- Fog lamps
- Rear A/C heater blower



POSITIONS	TERMINALS	RESISTANCE VALUE	POSITIONS	TERMINALS	RESISTANCE VALUE
HEADLAMP ON	B1 to C1	CONTINUITY	DIMMER LO-POSITION	B1 to A1	CONTINUITY
	A6 to C1	CONTINUITY		A6 to A1	CONTINUITY
	B1 to C4	CONTINUITY		A4 to A5	CONTINUITY
	A6 to C4	CONTINUITY		B1 to A1	210 - 390 Ω
PARKING LAMP ON	B1 to C4	CONTINUITY	DIMMER HI-POSITION	A6 to A1	210 - 390 Ω
	A6 to C4	CONTINUITY		A4 to A5	CONTINUITY
HAZARD WARNING OFF	B8 to B6	CONTINUITY	VACUUM FLUORESCENT ON	B1 to A1	7,000 - 13,000 Ω
	C8 to B3	CONTINUITY		A6 to A1	7,000 - 13,000 Ω
	B5 to B4	CONTINUITY		A4 to A5	CONTINUITY
HAZARD WARNING ON	B7 to B6	CONTINUITY	DIMMER ON-POSITION	B1 to A3	CONTINUITY
	C8 to C5	CONTINUITY		A6 to A3	CONTINUITY
	C8 to C6	CONTINUITY		B1 to A1	7,000 - 13,000 Ω
	C8 to B4	CONTINUITY		A6 to A1	7,000 - 13,000 Ω
	C7 to A6	CONTINUITY		A4 to A5	CONTINUITY
INTERIOR/DIMMER CONTROL SWITCH OFF	B1 to A1	CONTINUITY		B1 to A2	CONTINUITY
	A6 to A1	CONTINUITY		A6 to A2	CONTINUITY
				B1 to A1	7,000 - 13,000 Ω
			A6 to A1	7,000 - 13,000 Ω	

928E-44

Fig. 28 Headlamp POD Switch Continuity Test

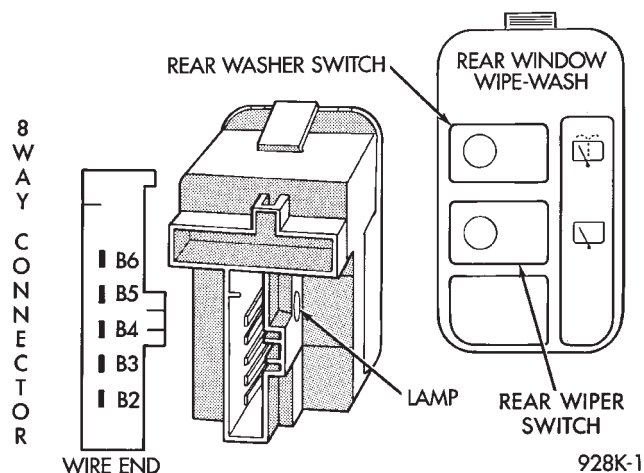

Fig. 29 Rear Wiper/Washer Control POD Switch

(1) Liftgate release switch operates with a push-on momentary action. The switch operates a relay to provide power to the liftgate solenoid. Vehicle must be in Park or Neutral and not moving for liftgate release switch to operate.

(2) The rear window defogger operates with a push-on and push-off momentary action. The switch portion of the carrier consists of a timer circuit, relay and a power management circuit. An amber indicator on the button shows when the switch is ON. Once the rear window defogger is ON, the system shall remain on until one of the following occurs:

- The switch is actuated again by push-off action.
- Ten minutes ±2 minutes has elapsed since the switch has been actuated
- The liftgate release switch is actuated. Under this condition, the rear window defogger relay contact is

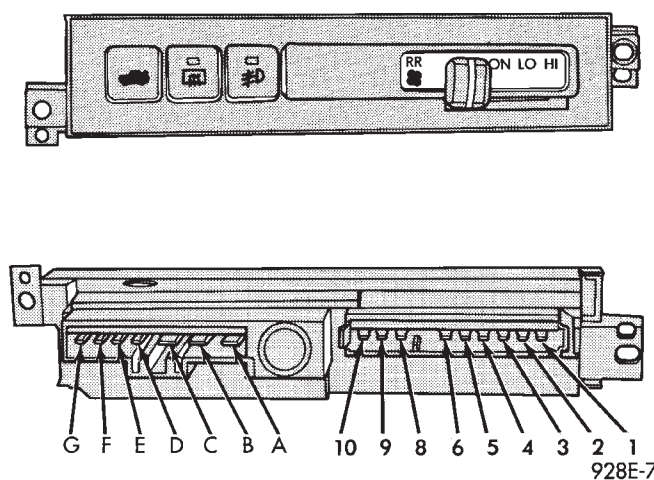

Fig. 30 Accessory Switch Carrier

temporary opened until the liftgate switch is released. This power management circuit prevents the printed circuit board of the accessory switch carrier from being damage by too much current flow.

(3) Fog lamp switch operates with a push-on and push-off momentary action. The switch portion of the carrier has a relay and an electronic latching circuit and the following:

- A green indicator on the button shows when the switch in ON.
- Fog lamps can be turned on only when the headlamps are on low beams.

(4) Power to the rear passenger compartment is controlled by the rear A/C header blower switch. The switch operates by a horizontal sliding action. The switch has four clearly defined detent positions:



- (a) The left most detent is OFF position.
- (b) The second detent from the left is the ON position. The ON position supplies power to the switch in the rear passenger compartment. When the switch is in any other position than ON, the rear passenger compartment switch is over ridden.
- (c) The third detent from the left is the Low position.
- (d) The fourth detent at the full right is the High position.

**ACCESSORY SWITCH CARRIER TEST**

- (1) Remove switch, refer to switch replacement.
- (2) Using a volt/ohm meter, refer to Fig. 31 for testing of wire end of connector while connected to switch.

**ACCESSORY SWITCH CARRIER REPLACEMENT**

- (1) Remove center bezel using a trim stick from instrument panel (Fig. 33).
- (2) Remove ash receiver lamp socket from bezel.
- (3) Remove accessory switch carrier from the panel (Fig. 30).
- (4) Disconnect wire connectors and lamp.
- (5) For installation reverse above procedures.

**A/C AND HEATER CONTROL/BLOWER SWITCH REPLACEMENT**

- (1) Remove center bezel using a trim stick from instrument panel (Fig. 33).
- (2) Remove ash receiver lamp socket from bezel.
- (3) Remove cigar lighter element.
- (4) Remove accessory switch carrier.

PIN	CONDITION	TEST FOR	CORRECTION
1	IGNITION SWITCH ON	12 VOLTS	CHECK A/C RELAY
2	REAR BLOWER SWITCH IN HIGH SPEED	12 VOLTS	REPLACE SWITCH
3	REAR BLOWER SWITCH IN LOW SPEED	12 VOLTS	REPLACE SWITCH
4	POWER TO REAR A/C HEATER SWITCH	12 VOLTS	REPLACE SWITCH
5			
6	HEADLAMP LOW BEAM ON	12 VOLTS	CHECK FUSE
7			
8			
9	FOG LAMP SWITCH ON W/LOW BEAM ON	12 VOLTS	REPLACE SWITCH
10	BATTERY	12 VOLTS	CHECK FUSE
A	REAR WINDOW DEFOGGER SWITCH ON	12 VOLTS	REPLACE SWITCH
B	BATTERY	12 VOLTS	CHECK FUSIBLE LINK
C	LIFTGATE SWITCH DEPRESSED	12 VOLTS	REPLACE SWITCH
D	IGNITION SWITCH ON	12 VOLTS	CHECK FUSE
E	GROUND	CONTINUITY	CHECK WIRING
F	ILLUMINATION LAMP	12 VOLTS	CHECK BODY CONTROLLER
G	GROUND	CONTINUITY	CHECK BODY CONTROLLER

928E-47

**Fig. 31 Accessory Switch Carrier Test**

- (3) Refer to Fig. 32 to test A/C heater switch. If continuity is not correct replace A/C heater switch.

TERMINAL	CONDITION	TEST FOR
1 - 2	OFF	NO CONTINUITY
1 - 3	OFF	NO CONTINUITY
1 - 4	OFF	NO CONTINUITY
1 - 4	ON	CONTINUITY
1 - 3	LOW	CONTINUITY
1 - 2	HIGH	CONTINUITY

928E-43

**Fig. 32 A/C Heater Switch Test**

- (5) Remove two screws and pull control assembly rearward. Reach behind control and disconnect the wiring harnesses, vacuum lines and temperature control cable (Fig. 34).

- (6) For installation reverse above procedures.

**A/C AND HEATER CONTROL LAMP REPLACEMENT**

- (1) Remove center bezel using a trim stick from instrument panel (Fig. 33).
- (2) Remove ash receiver lamp socket from bezel.
- (3) Remove cigar lighter element.
- (4) Remove accessory switch carrier.
- (5) Remove two screws and pull control assembly rearward. Reach behind control and disconnect lamp (Fig. 34).
- (6) For installation reverse above procedures.

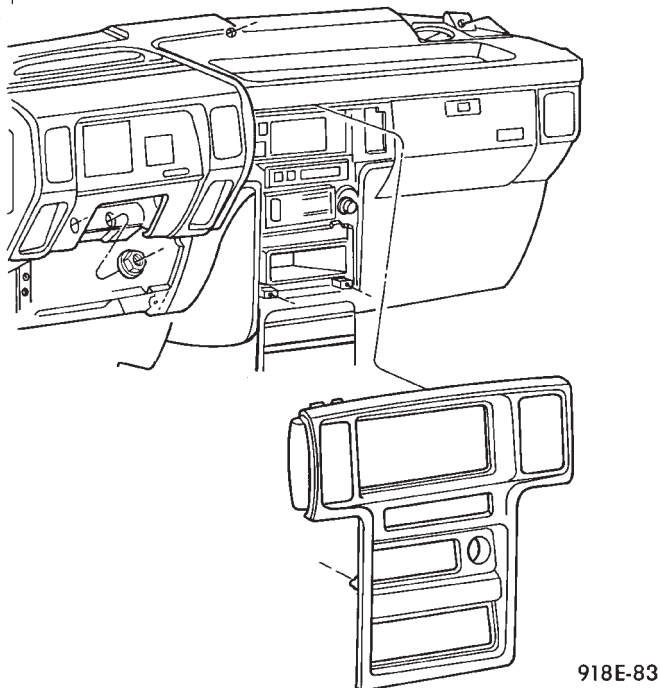

**Fig. 33 Center Bezel**

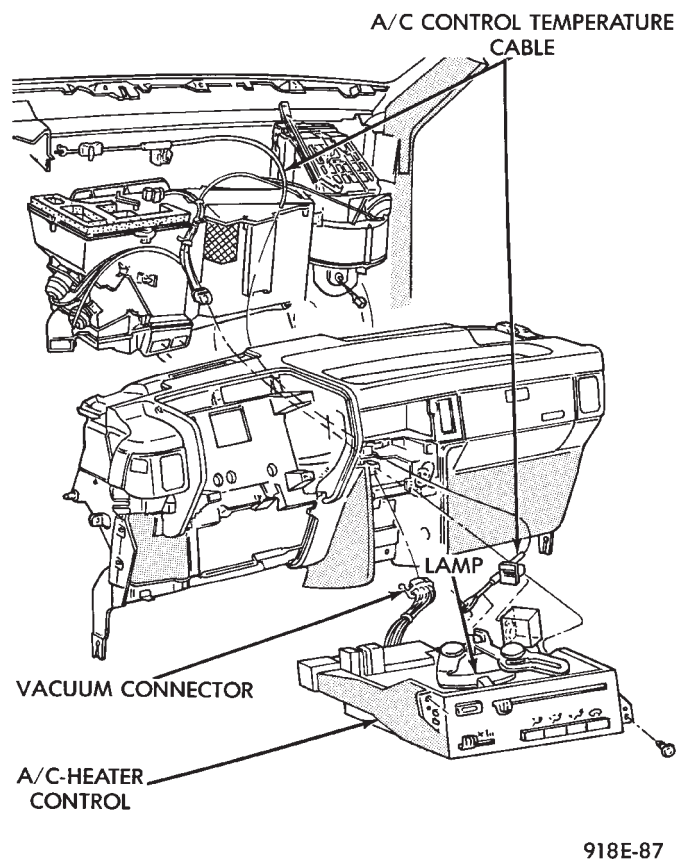
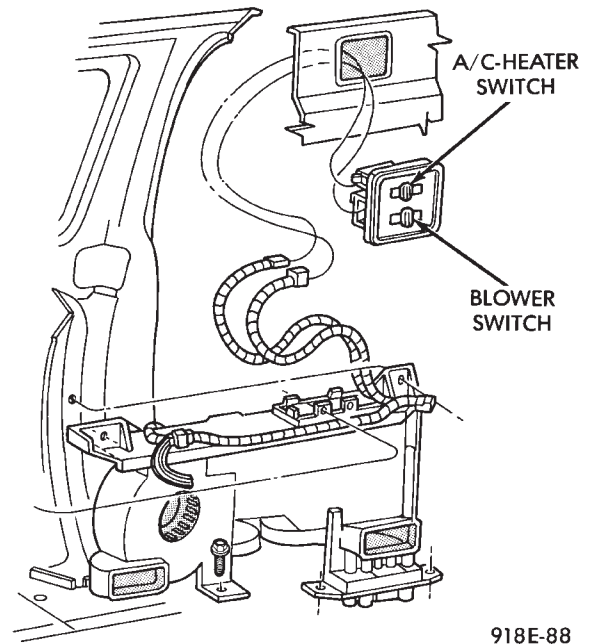

**Fig. 34 A/C Heater Control**

**REAR A/C-HEATER SWITCH REPLACEMENT**

For the blower switch on the instrument panel, refer to Accessory Switch Carrier Replacement (Fig. 30).

The rear A/C-heater switch assembly in the left rear quarter trim panel (Fig. 34).



**Fig. 35 Rear A/C Heater Control Switch**

- (1) Using a trim stick pry switch from left quarter trim panel.
- (2) Disconnect wire connectors.
- (3) For installation reverse above procedures.

**CIGAR LIGHTER REPLACEMENT**

- (1) Disconnect battery
- (2) Remove cigar lighter element.
- (3) Remove center trim bezel. Remove ash receiver lamp and socket if a equipped.
- (4) Remove accessory switch carrier attaching screws.
- (5) Remove A/C heater control attaching screws. Pull out and disconnect the wire connector and control cable(s).
- (6) Disconnect wire connectors and lamp/socket from rear of cigar lighter clamp.
- (7) Hold outer clamp, while turning shell. Do not lose cigar lighter shield (Fig. 36).
- (8) For installation reverse above procedures.

**FORWARD CONSOLE REMOVAL**

- (1) Remove center bezel using a trim stick from instrument panel (Fig. 33).
- (2) Remove ash receiver lamp socket from bezel.
- (3) Remove filler plate (Fig. 37).
- (4) Remove ash receiver/cup holding assembly from console. Refer to Ash Receiver Assembly for removal.
- (5) Remove screws attaching console to instrument panel:
  - Two upper corners
  - Two behind ash receiver

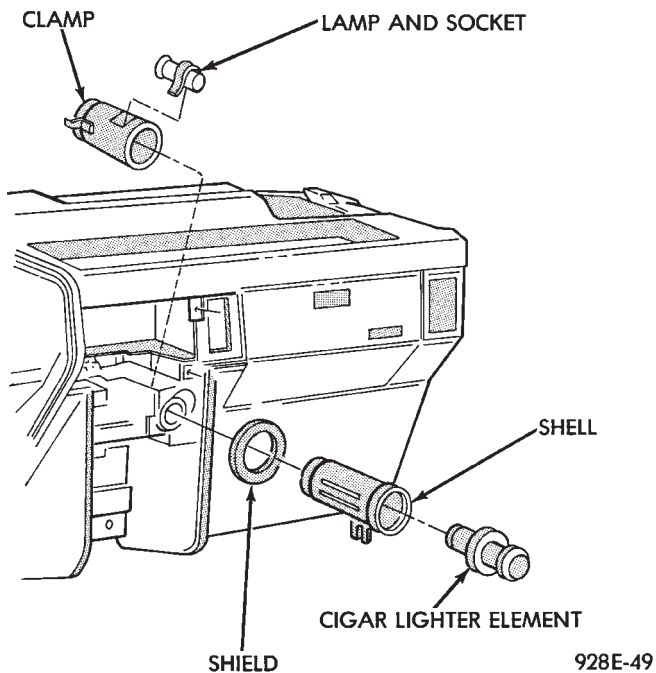

**Fig. 36 Cigar Lighter**

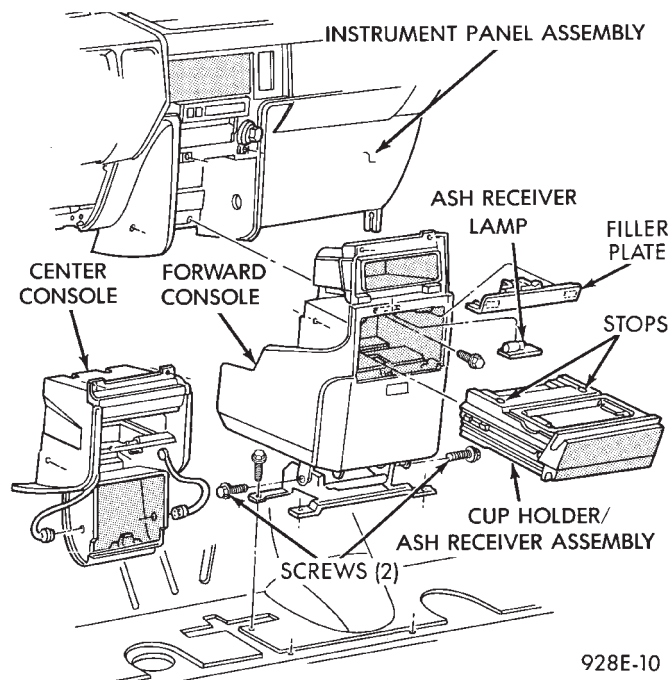

**Fig. 37 Forward and Center Console**

- Two at the lower bracket
- (6) Pull console rearward and disconnect wire connector and bulb.
- (7) Remove console.
- (8) For installation reverse above procedures.

#### CENTER STORAGE MODULE REMOVAL

- (1) Remove center bezel using a trim stick from instrument panel (Fig. 33).
- (2) Remove ash receiver lamp socket from bezel.

- (3) Remove ash receiver/cup holding assembly from console. Refer to Ash Receiver Assembly for removal.
- (4) Open the storage bin door and remove the check strap pins so that door swings fully open.
- (5) Remove four mounting screws and storage module.
- (6) For installation reverse above procedures.

#### ASH RECEIVER ASSEMBLY

Depress the ash receiver/cupholder assembly stops and remove by sliding rearward.

#### BODY CONTROLLER REPLACEMENT

(1) Remove steering column cover to gain access to the body controller (Fig. 38).

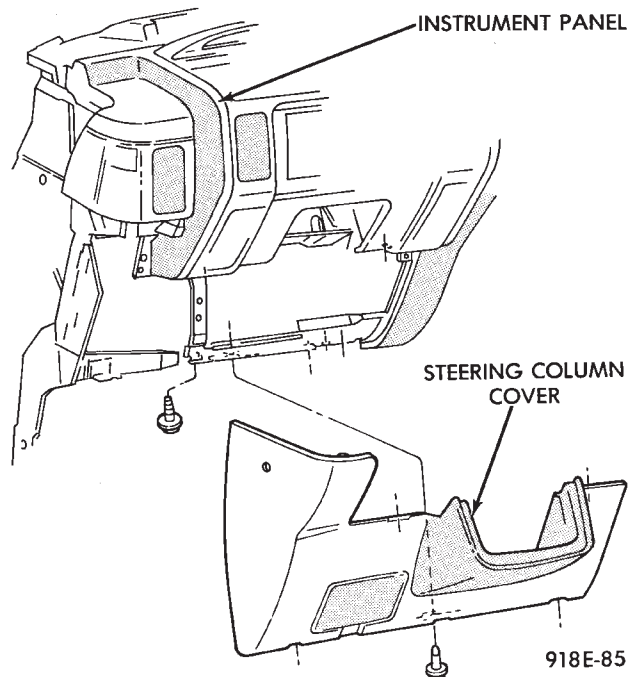
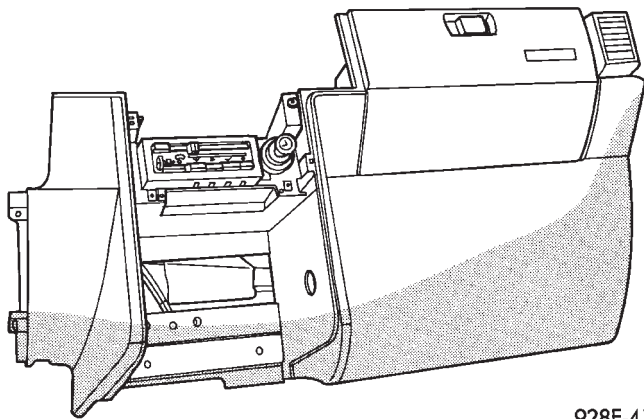

**Fig. 38 Instrument Panel Steering Column Cover**

- (2) Disconnect the two 25-way connectors from body controller.
- (3) Remove mounting screws from body controller.
- (4) Pull to the left to release body controller of S-clips and remove unit.
- (5) For installation reverse above procedures. Ensure body controller is locked into the S-clips.

#### LOWER RIGHT INSTRUMENT PANEL REPLACEMENT

- (1) Remove center console bezel using a trim stick from instrument panel (Fig. 33).
- (2) Remove accessory switch carrier.
- (3) Remove heater control (Fig. 34).
- (4) Disconnect cigar lighter.
- (5) Remove center or forward console, refer to removal procedures (Fig. 36).
- (6) Remove attaching screws and right lower panel (Fig. 39).



928E-41

**Fig. 39 Lower Right Instrument Panel**

(7) For installation reverse above procedures.

**INSTRUMENT PANEL REPLACEMENT**

**WARNING: CHOCK WHEELS WHEN LOWER PANEL IS TO BE ROLLED DOWN. THE STEERING COLUMN IS REMOVED AND TRANSMISSION MAY BE OUT OF PARK. RELEASE THE PARK BRAKE BEFORE THE RELEASE CABLE IS DISCONNECTED. DISCONNECTING PARK BRAKE CABLE WHILE PARK BRAKE IS ENGAGED MAY CAUSE PERSONAL INJURY.**

- (1) Remove steering column cover (Fig. 38). Set parking brake and shift gear selector into low.
- (2) Remove lower left instrument panel silencer.
- (3) Disconnect PRNDL at column.
  - (a) Unhook PRNDL cable eyelet from column actuating arm (Fig. 40).
  - (b) Release column insert lock tab.

• **RELEASE LOCK TAB BEFORE REMOVING INSERT—RELOCK AFTER INSTALLATION**

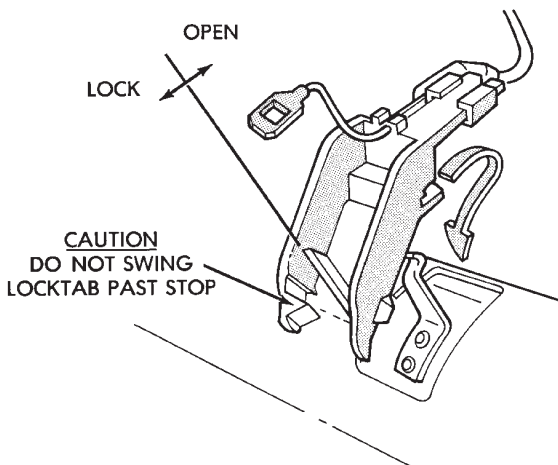

918E-62

**Fig. 40 PRNDL Release**

- (c) Squeeze legs together and lift insert from steering column, leave insert free.
- (d) Place cable on instrument panel to avoid PRNDL cable damage during removal.
- (4) Remove steering column, refer to Group 19, Steering.
- (5) Remove lower right instrument panel silencer (Fig. 41).
- (6) Remove forward console if necessary.
- (7) Remove instrument panel speaker grills.
- (8) Remove A-pillar intermediate and sill scuff garnish moldings.
- (9) Unfasten the hood release mechanism from the side cowl.
- (10) Unfasten the park brake handle bracket.
- (11) Disconnect the brake light switch, parking brake switch and bulk head wiring connectors.
- (12) Under the hood disconnect the ABS connector and resistor block. Unseat the grommet at the dash panel and feed wiring back into passenger compartment.
- (13) Remove the two nuts securing the instrument panel, at the steering column support brace.
- (14) Loosen the instrument panel roll up bolts.
- (15) Remove screw securing instrument panel at the left cowl side ramp bracket.
- (16) Remove the six screws securing the instrument panel at the fence line.
- (17) Lift upward on instrument panel to clear roll up ramp. Roll the instrument panel back and hang it from the short position of the roll up hook.
- (18) With instrument panel hanging in the short position disconnect the left side body wiring connections.
- (19) Roll the instrument panel to the long position on the roll up hook and perform the following operations:
  - (a) Disconnect the antenna cable.
  - (b) Disconnect the blower motor lead connection.
  - (c) Disconnect the temperature control cable from the A/C or heater unit.
  - (d) Disconnect the vacuum lines from the climate control assembly.
  - (e) Disconnect the right side body wiring connectors.
- (20) Remove instrument panel from vehicle.
- (21) For installation reverse above procedures.
- When installing cluster, do not kink or bind PRNDL guide tube and position guide tube in original location.
- Move shift lever to Neutral (N) and note pointer location. Move shift lever to D, L and P note pointer location. Adjust, if necessary to center pointer on N. Refer to Fig. 12 for adjusting procedure.



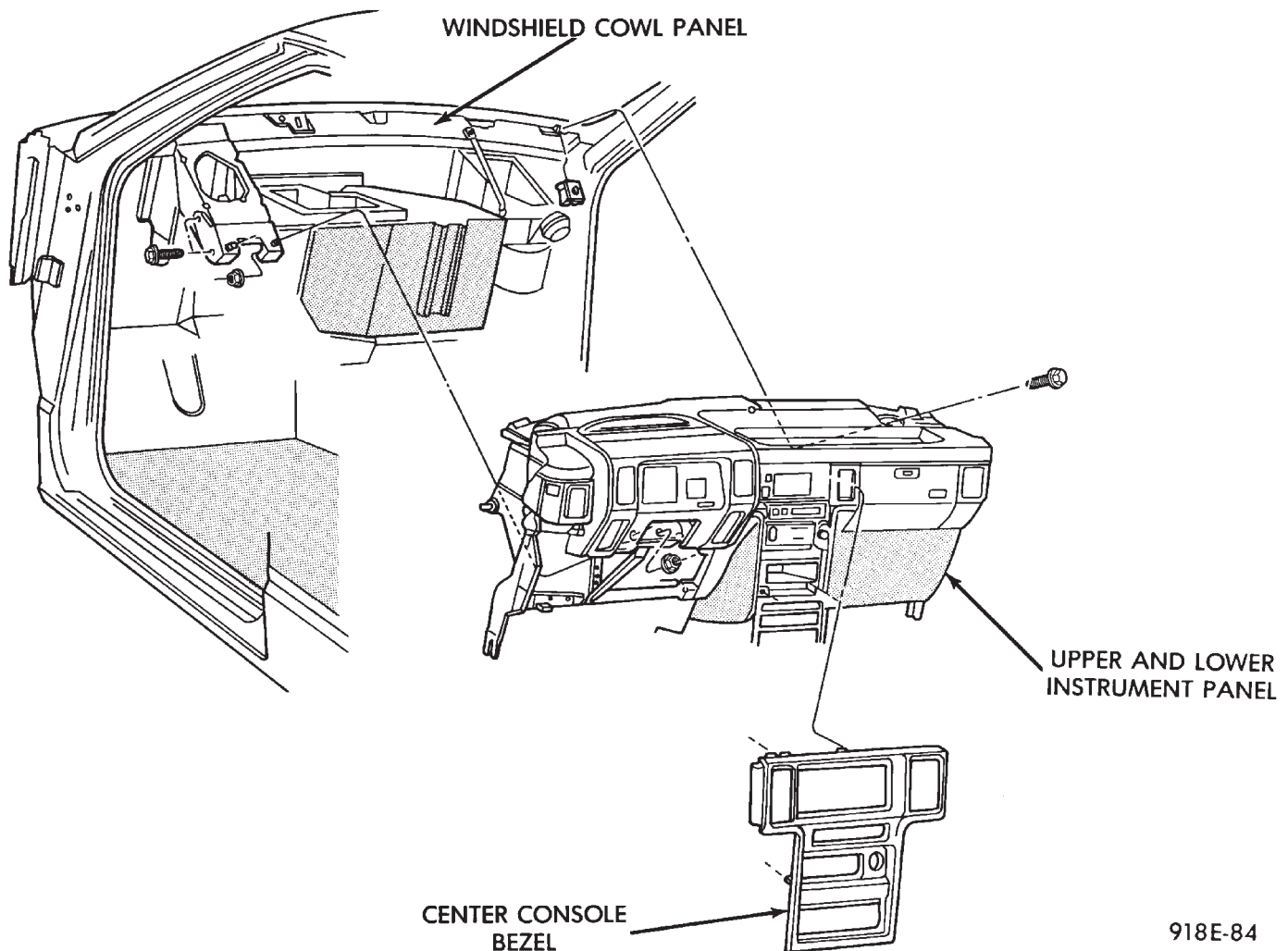

918E-84

**Fig. 41 Instrument Panel****DOOR COURTESY LAMP/REFLECTOR REPLACEMENT**

- (1) Detach door trim panel and all wiring.
- (2) Remove three screws to remove lamp or reflector.
- (3) For installation reverse above procedures.

**DOOR COURTESY LAMP BULB REPLACEMENT**

- (1) Use a flat edge tool to pry lens off the lamp assembly. Start at top and bottom forward portion of lamp lens and move rearward.
- (2) Replace bulb.
- (3) To install lens press until snap attachments engage.

**DOME LAMP**

- (1) Pry the lens from bezel.
- (2) Replace bulb.
- (3) To install lens press until snap attachments engage.

**LIFTGATE LAMP BULBS REPLACEMENT**

To service liftgate lamp bulb: The lens is part of speaker grille and cannot be removed separately.

- (1) Remove the speaker grille/lamp assembly from the trim panel by prying with a screw driver. There are two slots provided at the lower corners of the speaker grille.
- (2) Disconnect wire connector.
- (3) There is an insulator assembly on the back side of grille. Use a screw driver in slot provided to pry the insulator from the grille.
- (4) Replace bulb.
- (5) For installation reverse above procedures.

**GLOVEBOX LIGHT SWITCH REPLACEMENT**

- (1) Pry glovebox light switch from the glovebox (replace lamp if necessary).
- (2) Disconnect wire connector.
- (3) For installation reverse above procedures.

**PRNDL REPLACEMENT**

- (1) Remove warning indicator grille by prying up with a flat blade tool.



(2) Remove three mounting screws from the warning indicator module assembly and disconnect wire connector.

(3) Remove steering column cover (Fig. 38). Set parking brake and shift gear selector into low.

(4) Remove cluster bezel and disconnect wire connectors

(5) Remove four screws securing cluster. Rotate cluster and disconnect connector, to access PRNDL attaching screws. Remove two screws attaching PRNDL to cluster (Fig. 11).

(6) For electronic instrument cluster if equipped:

(a) Remove four screws securing cluster.

(b) Remove four screws attaching mask to housing.

(c) Rotate mask down then disconnect buttons and PRNDL.

(d) Remove two screws attaching PRNDL to mask.

(7) Remove cluster.

(8) Unhook PRNDL cable eyelet from column actuating arm (Fig. 40).

(9) Release column insert lock tab, squeeze legs together and lift insert from steering column, leave insert free.

(10) Remove PRNDL assembly.

(11) For installation reverse above procedures.

- When installing cluster, do not kink or bind PRNDL guide tube and position guide tube in original location.

- Move shift lever to Neutral (N) and note pointer location. Move shift lever to D, L and P note pointer location. Adjust, if necessary to center pointer on N. Refer to Fig. 12 for adjusting procedure.

