

ENGINE

CONTENTS

| | page | | page |
|-------------------|------|-----------------------------------|------|
| 2.5L ENGINE | 8 | 3.3L ENGINE | 82 |
| 3.0L ENGINE | 50 | STANDARD SERVICE PROCEDURES | 1 |

STANDARD SERVICE PROCEDURES

INDEX

| | page | | page |
|--|------|--|------|
| Crankshaft Sprocket Bolt Access Plug | 2 | Lash Adjuster (Tappet) Noise Diagnosis | 4 |
| Engine Performance | 2 | Measuring Main Bearing Clearance and Connecting Rod Bearing Clearance | 3 |
| Form-In-Place Gaskets | 1 | Repair of Damaged or Worn Threads | 4 |
| Honing Cylinder Bores | 2 | | |
| Hydrostatic Locked Engine | 5 | | |

FORM-IN-PLACE GASKETS

There are numerous places where form-in-place gaskets are used on the engine. Care must be taken when applying form-in-place gaskets. **Do not use form-in-place gasket material unless specifically called for.** Bead size, continuity, and location are of great importance. Too thin a bead can result in leakage while too much can result in spill-over, a continuous bead of the proper width is essential to obtain a leak-free joint.

Two types of form-in-place gasket materials are used in the engine area. MOPAR Silicone Rubber Adhesive Sealant and MOPAR Gasket Maker, each have different properties and cannot be used interchangeably.

MOPAR SILICONE RUBBER ADHESIVE SEALANT

MOPAR Silicone Rubber Adhesive Sealant or equivalent, normally black in color, is available in three ounce tubes. Moisture in the air causes the MOPAR Silicone Rubber Adhesive Sealant material to cure. This material is normally used on flexible metal flanges. It has a shelf life of one year and will not properly cure if over age. Always inspect the package for the expiration date before use.

MOPAR GASKET MAKER

MOPAR Gasket Maker is an anaerobic type gasket material normally red in color. The material cures in the absence of air when squeezed between two metallic surfaces. It will not cure if left in the uncovered tube. It

is normally red in color. The anaerobic material is for use between two machined surfaces. Do not used on flexible metal flanges.

GASKET DISASSEMBLY

Parts assembled with form-in-place gaskets may be disassembled without unusual effort. In some instances, it may be necessary to lightly tap the part with a mallet or other suitable tool to break the seal between the mating surfaces. A flat gasket scraper may also be lightly tapped into the joint but care must be taken not to damage the mating surfaces.

SURFACE PREPARATION

Scrape clean or wire brush all gasket surfaces to remove all loose material. Inspect stamped parts to ensure gasket rails are flat. Flatten rails with a hammer on a flat plate if required. Gasket surfaces must be free of oil and dirt. Make sure old gasket material is removed from blind attaching holes.

FORM-IN-PLACE GASKET APPLICATION

Assembling parts using a form-in-place gasket requires care but it's easier then using precut gaskets.

MOPAR Gasket Maker material should be applied sparingly 1mm(0.040 inch.) diameter or less of sealant to one gasket surface. Be certain the material surrounds each mounting hole. Excess material can easily be wiped off. Components should be torqued in place within 15 minutes. The use of a locating dowel is recommended during assembly to prevent smearing the material off location.

The MOPAR Silicone Rubber Adhesive Sealant gasket material or equivalent should be applied in a continuous bead approximately 3mm (0.120 inch) in diameter. All mounting holes must be circled. For corner sealing, a 3.17 or 6.35 mm (1/8 or 1/4 inch.) drop is placed in the center of the gasket contact area. Uncured sealant may be removed with a shop towels. Components should be torqued in place while the sealant is still wet to the touch (within 10 minutes). The usage of a locating dowel is recommended during assembly to prevent smearing of material off location.

CRANKSHAFT SPROCKET BOLT ACCESS PLUG

An Access plug is located in the right inner fender shield. Remove the plug and insert proper size socket, extension and ratchet, when crankshaft rotation is necessary.

ENGINE PERFORMANCE

If a loss of performance is noticed, ignition timing should be checked. If ignition timing is retarded by 9, 18 or 27° indicating 1, 2 or 3 (timing belt) teeth may have skipped, then, camshaft and accessory shaft timing with the crankshaft should be checked. Refer to Engine Timing Sprockets and Oil Seals of the Engine Section.

To provide best vehicle performance and lowest vehicle emissions, it is most important that the tune-up be done accurately. Use the specifications listed on the Vehicle Emission Control Information label found in the engine compartment.

(1) Test cranking amperage draw. See Starting Motor Cranking Amperage Draw Electrical Section of this manual.

(2) Tighten the intake manifold bolts to specifications.

(3) Perform cylinder compression test.

(a) Check engine oil level and add oil if necessary.

(b) Drive the vehicle until engine reaches normal operating temperature.

(c) Select a route free from traffic and other forms of congestion, observe all traffic laws, and accelerate through the gears several times briskly.

CAUTION: Do not overspeed the engine. The higher engine speed may help clean out valve seat deposits which can prevent accurate compression readings.

(d) Remove all spark plugs from engine. As spark plugs are being removed, check electrodes for abnormal firing indicators fouled, hot, oily, etc. Record cylinder number of spark plug for future reference.

(e) Disconnect coil wire from distributor and secure to good ground to prevent a spark from starting a fire (Conventional Ignition System). For Direct Ignition System DIS disconnect the coil connector.

(f) Be sure throttle blade is fully open during the compression check.

(g) Insert compression gage adaptor into the #1 spark plug hole in cylinder head. Crank engine until maximum pressure is reached on gage. Record this pressure as #1 cylinder pressure.

(h) Repeat Step G for all remaining cylinders.

(i) Compression should not be less than (689kPa) 100 psi and not vary more than 25 percent from cylinder to cylinder.

(j) If one or more cylinders have abnormally low compression pressures, repeat steps 4b through 4h.

(k) If the same cylinder or cylinders repeat an abnormally low reading on the second compression test, it could indicate the existence of a problem in the cylinder in question.

The recommended compression pressures are to be used only as a guide to diagnosing engine problems. An engine should not be disassembled to determine the cause of low compression unless some malfunction is present.

(4) Clean or replace spark plugs as necessary and adjust gap as specified in Electrical Group 8. Tighten to specifications.

(5) Test resistance of spark plug cables. Refer to Ignition System Secondary Circuit Inspection Electrical Section Group 8.

(6) Inspect the primary wire. Test coil output voltage, primary and secondary resistance. Replace parts as necessary. Refer to Ignition System and make necessary adjustment.

(7) Ignition timing should be set to specifications. (See Specification Label in engine compartment).

(8) Test fuel pump for pressure and vacuum. Refer to Fuel System Group 14, Specifications.

(9) The air filter elements should be replaced as specified in Lubrication and Maintenance, Group 0.

(10) Inspect crankcase ventilation system as outlined in Lubrication and Maintenance, Group 0. For emission controls see Emission Controls Group 25 for service procedures.

(11) Inspect and adjust accessory belt drives referring to Accessory Belt Drive in Cooling System, Group 7 for proper adjustments.

(12) Road test vehicle as a final test.

HONING CYLINDER BORES

Before honing, stuff plenty of clean shop towels under the bores, over the crankshaft to keep abrasive materials from entering crankcase area.

(1) Used carefully, the cylinder bore resizing hone C-823 equipped with 220 grit stones, is the best tool for this job. In addition to deglazing, it will reduce taper and out-of-round as well as removing light

scuffing, scoring or scratches. Usually a few strokes will clean up a bore and maintain the required limits.

(2) Deglazing of the cylinder walls may be done using a cylinder surfacing hone, Tool C-3501, equipped with 280 grit stones (C-3501-3810) if the cylinder bore is straight and round. 20-60 strokes depending on the bore condition will be sufficient to provide a satisfactory surface. Inspect cylinder walls after each 20 strokes. Using a light honing oil available from major oil distributors. **Do not use engine or transmission oil, mineral spirits or kerosene.**

(3) Honing should be done by moving the hone up and down fast enough to get a cross-hatch pattern. When hone marks **intersect** at 50-60 degrees, the cross hatch angle is most satisfactory for proper seating of rings (Fig. 1).

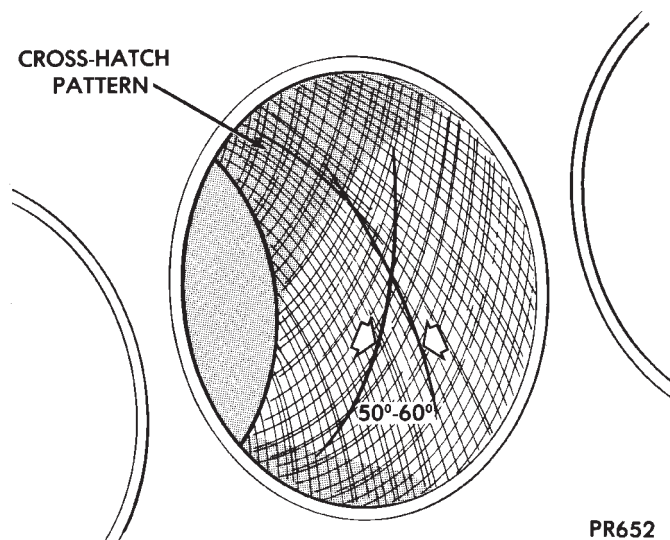

Fig. 1 Cylinder Bore Cross-Hatch Pattern

(4) A controlled hone motor speed between 200-300 RPM is necessary to obtain the proper cross-hatch angle. The number of up and down strokes per minute can be regulated to get the desired 50-60 degree angle. Faster up and down strokes increase the cross-hatch angle.

(5) After honing, it is necessary that the block be cleaned again to remove all traces of abrasive.

CAUTION: Be sure all abrasive are removed from engine parts after honing. It is recommended that a solution of soap and hot water be used with a brush and the parts then thoroughly dried. The bore can be considered clean when it can be wiped clean with a white cloth and cloth remains clean. Oil the bores after cleaning to prevent rusting.

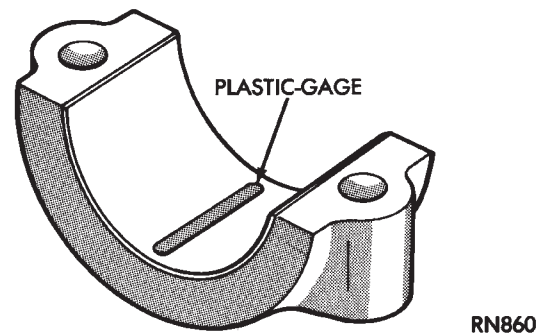

Fig. 2 Plastigage Placed in Lower Shell

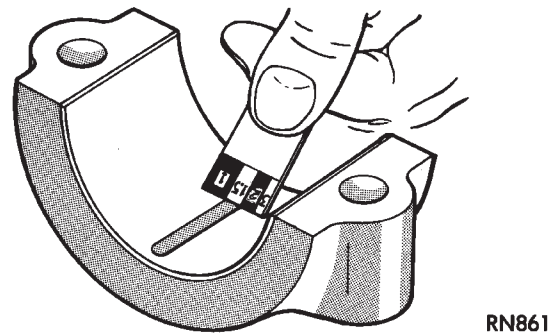

Fig. 3 Clearance Measurement

MEASURING MAIN BEARING CLEARANCE AND CONNECTING ROD BEARING CLEARANCE

PLASTIGAGE METHOD

Engine crankshaft bearing clearances can be determined by use of Plastigage or equivalent. The following is the recommended procedure for the use of Plastigage:

(1) Remove oil film from surface to be checked. Plastigage is soluble in oil.

(2) The total clearance of the **main bearings** can only be determined by removing the weight of the crankshaft. This can be accomplished by either of two methods:

PREFERRED METHOD — Shimming the bearings adjacent to the bearing to be checked in order to remove the clearance between upper bearing shell and the crankshaft. This can be accomplished by placing a minimum of 0.254mm (.010 inch) shim (e. g. cardboard, matchbook cover, etc.) between the bearing shell and the bearing cap on the adjacent bearings and snugging bolts to 14-20 N•m (10-15 ft.lb.)

- When checking #1 main brg shim #2 main brg
- When checking #2 main brg shim #1 & 3 main brg
- When checking #3 main brg shim #2 & 4 main brg
- When checking #4 main brg shim #3 & 5 main brg
- When checking #5 main brg shim #4 main brg

REMOVE ALL SHIMS BEFORE REASSEMBLING ENGINE

ALTERNATIVE METHOD — With the weight of the crankshaft being supported by a jack under the counterweight adjacent to the bearing being checked.

(3) Place a piece of Plastigage across the entire width of the bearing shell in the cap approximately 6.35mm (1/4 inch) off center and away from the oil holes (Fig. 2). (In addition, suspect areas can be checked by placing the Plastigage in the suspect area). Torque the bearing cap bolts of the bearing being checked to the proper specifications.

(4) Remove the bearing cap and compare the width of the flattened Plastigage (Fig. 3) with the metric scale provided on the package. Locate the band closest to the same width. This band shows the amount of clearance in thousandths of a millimeter. Differences in readings between the ends indicate the amount of taper present. Record all readings taken. Refer to Engine Specifications. **Plastigage generally is accompanied by two scales. One scale is in inches, the other is a metric scale.**

(5) Plastigage is available in a variety of clearance ranges. The 0.025-0.076mm (.001-.003 inch) is usually the most appropriate for checking engine bearing proper specifications.

CONNECTING ROD BEARING CLEARANCE

Engine crankshaft bearing clearances can be determined by use of Plastigage or equivalent. The following is the recommended procedure for the use of Plastigage:

(1) Rotate the crankshaft until the connecting rod to be checked is at the bottom of its stroke.

(2) Remove oil film from surface to be checked. Plastigage is soluble in oil.

(3) Place a piece of Plastigage across the entire width of the bearing shell in the bearing cap approximately 6.35 mm (1/4 inch.) off center and away from the oil hole (Fig. 2). In addition, suspect areas can be checked by placing plastigage in the suspect area.

(4) Before assembling the rod cap with Plastigage in place, the crankshaft must be rotated until the connecting being checked starts moving toward the top of the engine. Only then should the cap be assembled and torqued to specifications. **Do not rotate the crankshaft while assembling the cap or the Plastigage may be smeared, giving inaccurate results.**

(5) Remove the bearing cap and compare the width of the flattened Plastigage (Fig. 3) with the metric scale provided on the package. Locate the band closest to the same width. This band shows the amount of clearance in thousandths of a millimeter. Differences in readings between the ends indicate the amount of taper present. Record all readings taken. Refer to Engine Specifications. **Plastigage generally is accompanied by two scales. One scale is in inches, the other is a metric scale.**

(6) Plastigage is available in a variety of clearance ranges. The 0.025-0.076mm (.001-.003 inch) is usually the most appropriate for checking engine bearing proper specifications.

LASH ADJUSTER (TAPPET) NOISE DIAGNOSIS

A tappet-like noise may be produced from several items. Check the following items.

(1) Engine oil level too high or too low. This may cause aerated oil to enter the adjusters and cause them to be spongy.

(2) Insufficient running time after rebuilding cylinder head. Low speed running up to 1 hour may be required.

During this time, turn engine off and let set for a few minutes before restarting. Repeat this several times after engine has reached normal operating temperature.

(3) Low oil pressure.

(4) The oil restrictor pressed into the vertical oil passage to the cylinder head Balance Shaft Engines Only is plugged with debris.

(5) Air ingested into oil due to broken or cracked oil pump pick up.

(6) Worn valve guides.

(7) Rocker arm ears contacting valve spring retainer (2.5L engines).

(8) Rocker arm loose, adjuster stuck or at maximum extension and still leaves lash in the system.

(9) Faulty lash adjuster.

(a) Check for sponginess while still installed in cylinder head. Depress part of rocker arm just over adjuster. Normal adjusters should feel very firm. Spongy adjusters can be depressed to the bottomed position easily.

(b) Remove suspected lash adjusters, pry off retainer cap and disassemble **Do not reuse retainer caps.** Do not interchange parts and make sure that care and cleanliness is exercised in the handling of parts.

(c) Clean out dirt and varnish with solvent.

(d) Reassemble with engine oil.

(e) Check for sponginess.

(f) If still spongy, replace with new adjuster.

REPAIR OF DAMAGED OR WORN THREADS

Damaged or worn threads (including aluminum head spark plug threads) can be repaired. Essentially, this repair consists of drilling out worn or damaged threads, tapping the hole with a special Heli-Coil (or equivalent) Tap, and installing an insert into the tapped hole. This brings the hole back to its original thread size.

CAUTION: Be sure that the tapped holes maintain the original centerline.

Heli-Coil tools and inserts are readily available from automotive parts jobbers.

HYDROSTATIC LOCKED ENGINE

When an engine is suspected to be hydrostatically locked, regardless of what caused the problem, these steps should be used.

CAUTION: Do Not Use Starter Motor To Rotate Engine, severe damage may occur.

(1) Inspect air cleaner, induction system and intake manifold to insure system is dry and clear of foreign material.

(2) Remove negative battery cable.

(3) Place a shop towel around the spark plugs when removing them from the engine. This will catch any fluid that may possibly be in the cylinder under pressure.

(4) With all spark plugs removed, rotate engine crankshaft using a breaker bar and socket.

(5) Identify the fluid in the cylinder(s) (i.e., coolant, fuel, oil or other).

(6) Make sure all fluid has been removed from the cylinders. Inspect engine for damage (i.e., Connecting Rods, Pistons, Valves etc.)

(7) Repair engine or components as necessary to prevent this problem from occurring again.

CAUTION: Squirt approximately 1 teaspoon of oil into cylinders, rotate engine to lubricate the cylinder walls to prevent damage on restart.

(8) Install new spark plugs.

(9) Drain engine oil and remove oil filter.

(10) Fill engine with specified amount of approved oil and install new oil filter.

(11) Connect negative battery cable.

(12) Start engine and check for any leaks.

ENGINE DIAGNOSIS—PERFORMANCE

| CONDITION | POSSIBLE CAUSES | CORRECTION |
|-------------------------------|---|--|
| ENGINE WILL NOT START | <ol style="list-style-type: none"> 1. Weak battery. 2. Corroded or loose battery connections. 3. Faulty starter. 4. Moisture on ignition wires and distributor cap. 5. Faulty ignition cables. 6. Faulty coil or control unit. 7. Incorrect spark plug gap. 8. Incorrect ignition timing. 9. Dirt or water in fuel system. 10. Faulty fuel pump. | <ol style="list-style-type: none"> 1. Test battery specific gravity. Charge or replace as necessary. 2. Clean and tighten battery connections. Apply a coat of light mineral grease to the terminals. 3. Refer to Group 8A, Battery/Starter/Charging System Diagnostics. 4. Wipe wires and cap clean and dry. 5. Replace any cracked or shorted cables. 6. Test and replace, if necessary (refer to Group 8D, Ignition System). 7. Set gap (refer to Group 8D, Ignition System). 8. Refer to Group 8D, Ignition System. 9. Clean system and replace fuel filter. 10. Install new fuel pump (refer to Group 14, Fuel System). |
| ENGINE STALLS OR ROUGH IDLE | <ol style="list-style-type: none"> 1. Idle speed set too low. 2. Idle mixture too lean or too rich. 3. Leak in intake manifold. 4. Worn or burned distributor rotor. 5. Incorrect ignition wiring. 6. Faulty coil. 7. EGR valve leaking. | <ol style="list-style-type: none"> 1. Refer to Group 14, Fuel System. 2. Refer to Group 14, Fuel System. 3. Inspect intake manifold gasket and vacuum hoses. Replace, if necessary (refer to Group 11, Exhaust System & Intake Manifold). 4. Install new distributor rotor. 5. Install correct wiring. 6. Test and replace, if necessary (refer to Group 8D, Ignition System). 7. Test and replace, if necessary (refer to Group 25, Emissions Control System). |
| ENGINE LOSS OF POWER | <ol style="list-style-type: none"> 1. Incorrect ignition timing. 2. Worn or burned distributor rotor. 3. Worn distributor shaft. 4. Dirty or incorrectly gapped spark plugs. 5. Dirt or water in fuel system. 6. Faulty fuel pump. 7. Incorrect valve timing. 8. Blown cylinder head gasket. 9. Low compression. 10. Burned, warped or pitted valves. 11. Plugged or restricted exhaust system. 12. Faulty ignition cables. 13. Faulty coil. | <ol style="list-style-type: none"> 1. Refer to Group 8D, Ignition System. 2. Install new distributor rotor. 3. Remove and repair distributor (refer to Group 8D, Ignition System). 4. Clean plugs and set gap (refer to Group 8D, Ignition System). 5. Clean system and replace fuel filter. 6. Install new fuel pump. 7. Correct valve timing. 8. Install new cylinder head gasket. 9. Test compression of each cylinder. 10. Install new valves. 11. Install new parts, as necessary. 12. Replace any cracked or shorted cables. 13. Test and replace, as necessary (refer to Group 8D, Ignition System). |
| ENGINE MISSES ON ACCELERATION | <ol style="list-style-type: none"> 1. Dirty or gap set too wide in spark plug. 2. Incorrect ignition timing. 3. Dirt in fuel system. 4. Burned, warped or pitted valves. 5. Faulty coil. | <ol style="list-style-type: none"> 1. Clean spark plugs and set gap (refer to Group 8D, Ignition System). 2. Refer to Group 8D, Ignition System. 3. Clean fuel system. 4. Install new valves. 5. Test and replace, if necessary, (refer to Group 8D, Ignition System). |
| ENGINE MISSES AT HIGH SPEED | <ol style="list-style-type: none"> 1. Dirty or gap set too wide in spark plug. 2. Worn distributor shaft. 3. Worn or burned distributor rotor. 4. Faulty coil. 5. Incorrect ignition timing. 6. Dirty injector in throttle body. 7. Dirt or water in fuel system. | <ol style="list-style-type: none"> 1. Clean spark plugs and set gap (refer to Group 8D, Ignition System). 2. Remove and repair distributor (refer to Group 8D, Ignition System). 3. Install new distributor rotor. 4. Test and replace, as necessary (refer to Group 8D, Ignition System). 5. Refer to Group 8D, Ignition System. 6. Clean injector. 7. Clean system and replace fuel filter. |



ENGINE DIAGNOSIS—MECHANICAL

| CONDITION | POSSIBLE CAUSES | CORRECTION |
|---|---|--|
| NOISY VALVES | <ol style="list-style-type: none"> 1. High or low oil level in crankcase. 2. Thin or diluted oil. 3. Low oil pressure. 4. Dirt in tappets/lash adjusters. 5. Bent push rods. 6. Worn rocker arms. 7. Worn tappets/lash adjusters. 8. Worn valve guides. 9. Excessive runout of valve seats on valve faces. | <ol style="list-style-type: none"> 1. Check for correct oil level (refer to Group 0, Lubrication and Maintenance). 2. Change oil (refer to Group 0, Lubrication and Maintenance). 3. Check engine oil level. 4. Clean hydraulic tappets/hydraulic lash adjusters. 5. Install new push rods. 6. Inspect oil supply to rocker arms. 7. Install new hydraulic tappets/hydraulic lash adjusters. 8. Ream and install new valves with oversize stems. 9. Grind valve seats and valves. |
| CONNECTING ROD NOISE | <ol style="list-style-type: none"> 1. Insufficient oil supply. 2. Low oil pressure. 3. Thin or diluted oil. 4. Excessive bearing clearance. 5. Connecting rod journal out-of-round. 6. Misaligned connecting rods. | <ol style="list-style-type: none"> 1. Check engine oil level (refer to Group 0, Lubrication and Maintenance). 2. Check engine oil level. Inspect oil pump relief valve and spring. 3. Change oil to correct viscosity. 4. Measure bearings for correct clearance. Repair as necessary. 5. Replace crankshaft or grind journals. 6. Replace bent connecting rods. |
| MAIN BEARING NOISE | <ol style="list-style-type: none"> 1. Insufficient oil supply. 2. Low oil pressure. 3. Thin or diluted oil. 4. Excessive bearing clearance. 5. Excessive end play. 6. Crankshaft journal out-of-round, worn. 7. Loose flywheel or torque converter. | <ol style="list-style-type: none"> 1. Check engine oil level (refer to Group 0, Lubrication and Maintenance). 2. Check engine oil level. Inspect oil pump relief valve and spring. 3. Change oil to correct viscosity. 4. Measure bearings for correct clearance. Repair as necessary. 5. Check No. 3 main bearing for wear on flanges. 6. Grind journals or replace crankshaft. 7. Tighten to correct torque. |
| OIL PRESSURE DROP | <ol style="list-style-type: none"> 1. Low oil level. 2. Faulty oil pressure sending unit. 3. Low oil pressure. 4. Clogged oil filter. 5. Worn parts in oil pump. 6. Thin or diluted oil. 7. Excessive bearing clearance. 8. Oil pump relief valve stuck. 9. Oil pump suction tube loose, bent or cracked. 10. Oil pump cover warped or cracked. | <ol style="list-style-type: none"> 1. Check engine oil level. 2. Install new sending unit. 3. Check sending unit and check main bearing oil clearance. 4. Install new oil filter. 5. Replace worn parts or pump. 6. Change oil to correct viscosity. 7. Measure bearings for correct clearance. 8. Remove valve and inspect, clean and install. 9. Remove oil pan and install new tube, if necessary. 10. Install new oil pump. |
| OIL LEAKS | <ol style="list-style-type: none"> 1. Misaligned or deteriorated gaskets. 2. Loose fastener, broken or porous metal part. | <ol style="list-style-type: none"> 1. Replace the gasket. 2. Tighten, repair or replace the part. |
| OIL CONSUMPTION OR SPARK PLUGS OIL FOULED | <ol style="list-style-type: none"> 1. PCV system malfunction. 2. Worn, scuffed or broken rings. 3. Carbon in oil ring slot. 4. Rings fitted too tightly in grooves. 5. Worn valve guides. 6. Valve stem seal unseated or defective. | <ol style="list-style-type: none"> 1. Check system. Clean and repair, as necessary (refer to Group 25, Emissions Control System). 2. Hone cylinder bores. Install new rings. 3. Install new rings. 4. Remove the rings. Check grooves. If groove is not proper width, replace piston. 5. Ream guides and replace valves with oversize valves and seals. 6. Repair or replace seal. |

2.5L ENGINE

INDEX

| | page | | page |
|--|------|--|------|
| Balance Shafts | 37 | Engine Assembly | 11 |
| Camshaft, Crankshaft and Intermediate Shafts | | Engine Core Plugs | 31 |
| Timing Procedure | 17 | Engine Lubrication System | 41 |
| Checking Engine Oil Pressure | 46 | Engine Mounts | 9 |
| Crankshaft Oil Seals Service | 34 | Engine Specifications | 47 |
| Crankshaft Service | 35 | General Information | 8 |
| Crankshaft, Intermediate and Balance Shaft | | Intermediate Shaft Service | 39 |
| Assemblies Service | 33 | Oil Filter | 46 |
| Cylinder Block, Piston and Connecting Rod | | Oil Pan | 43 |
| Assembly Service | 27 | Oil Pump Service | 43 |
| Cylinder Head | 22 | Solid Mount Compressor Bracket Service | 13 |
| Cylinder Head and Valve Assembly Service | 18 | Timing System and Seals Service | 14 |
| Cylinder Head Components—In-Vehicle Service | 19 | Valve Service—Cylinder Head Removed | 23 |

SPECIFICATIONS

| | |
|--------------------------------|--|
| Type | In Line 4 Cylinder SOHC |
| Bore and Stroke | |
| 2.5L | 87.5 x 104 mm (3.44 x 4.09 inch) |
| Displacement | |
| 2.5L | 2.5L (153 Cubic Inch) |
| Compression Ratio | |
| (Fuel Induction System) | |
| 2.5L | 8.9:1 (TBI) |
| Torque | |
| 2.5L | 183 N·m (135 Lbs. Ft.) @ 2,800 |
| Firing Order | 1-3-4-2 |
| Lubrication | Pressure Feed-Full Flow Filtration |
| Engine Oil Capacity | 3.8 Liters (4.0 qts.) without oil filter change, 4.25 Liters (4.5 qts.) with oil filter change. |
| Cooling System | Liquid Cooled-Forced Circulation |
| Cylinder Block | Cast Iron |
| Crankshaft | Cast Nodular Iron |
| Cylinder Head | Aluminum Alloy with "Fast Burn" Design Combustion Chambers |
| Camshaft | Nodular Iron with Roller Followers |
| Pistons | Cast Aluminum Alloy (Strutless) |
| Piston (Top) Relief | Dished w/Valve Cut |
| Connecting Rods | Forged Steel |

9209-11

GENERAL INFORMATION

ENGINE IDENTIFICATION NUMBER OR CODE

The engine identification number is located on the rear of the cylinder block just below the cylinder head (Fig. 1).

BLOCK: All four cylinder cast iron blocks have cast-in recesses in the bottom of each cylinder bore to provide connecting rod clearance; especially for 2.5L engines. The bores are also siamese to minimize engine length. A partial open deck is used for cooling and weight reduction with oil filter, water pump, and distributor mounting bosses molded into the front (radiator side) of the block. Nominal wall thickness is 4.5 mm. Five main bearing bulkheads and a block skirt

extending 3 mm below the crankshaft center line add to the blocks high rigidity with light weight.

CRANKSHAFT: A nodular cast iron crankshaft that is used in 2.5L engine. These engines have 5 main bearings, with number 3 flanged to control thrust. The 60 mm diameter main and 50 mm diameter crank pin journals (all) have undercut radiused fillets that are deep rolled for added strength. To optimize bearing loading 4 counterweights are used. Hydrodynamic seals (installed in diecast aluminum retainers) provides end sealing, where the crankshaft exits the block. Anaerobic gasket material is used for retainer-to-block sealing. No vibration damper is used. A sintered iron timing belt sprocket is mounted

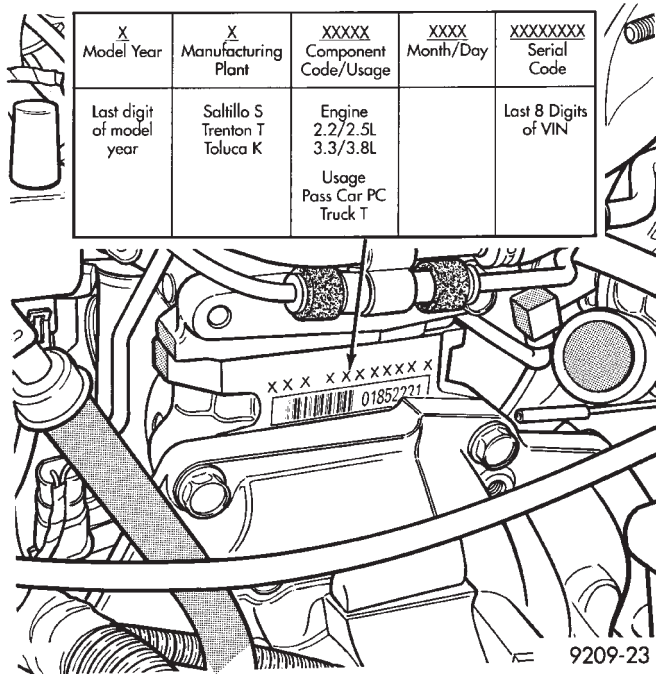

Fig. 1 Engine Identification

on the crankshaft nose. This sprocket provides motive power; via timing belt to the camshaft and intermediate shaft sprockets (also sintered iron) providing timed valve, distributor, and oil pump actuation.

PISTONS: Some Chrysler pistons have cast-in steel struts at the pin bosses for autothermic control. All 2.5L pistons have valve cuts to provide valve clearance. Some pistons are dished to provide various compression ratios. Standard 2.5L engines are designed for 8.9:1 compression ratios respectively. The standard 2.5L piston is dished and is a new lightweight design to further enhance engine smoothness. All standard 2.5L engines use pressed-in piston pins to attach forged steel connecting rods.

CYLINDER HEAD: The cylinder head is cast aluminum with in-line valves arranged with alternating exhaust and intake. The intake and exhaust ports are located in the rearward, facing side of the head. The intake ports feed fast-burn design combustion chambers with spark plugs located close to the center line of the combustion chamber for optimum efficiency. An integral oil gallery within the cylinder head supplies oil to the hydraulic lash adjusters, camshaft, and valve mechanisms.

CAMSHAFT: The nodular iron camshaft has five bearing journals. Flanges at the rear journal control camshaft end play. A sintered iron timing belt sprocket is mounted on the cam nose, and a hydrodynamic oil seal is used for oil control at the front of the camshaft.

ACCESSORY SHAFT: The iron accessory shaft has two bearing journals and is housed in the forward facing side of the block. A hydrodynamic seal, installed in an aluminum housing attached to the block, provides retention, shaft thrust, and oil control. The

accessory shaft is driven by the timing belt through a sintered iron sprocket mounted on the nose of the accessory shaft. The accessory shaft in turn drives the oil pump and distributor.

VALVES: The valves are actuated by roller cam followers which pivot on stationary hydraulic lash adjusters.

The valve train with 40.6 mm (1.60 inch) diameter intake valves and 35.4 mm (1.39 inch) diameter exhaust valves employ viton rubber valve stem seals. Valve springs, spring retainers, and locks are conventional.

BALANCE SHAFTS: 2.5L engines are equipped with two balance shafts installed in a carrier attached to the lower crankcase. The shafts interconnect through gears to rotate in opposite directions. These gears are driven by a short chain from the crankshaft, to rotate at two times crankshaft speed. This counterbalances certain engine reciprocating masses.

INTAKE MANIFOLDS: All intake manifolds are aluminum castings. N.A. engines use a four branch design. This long branch fan design enhances low and midspeed torque and also features an integrally cast water crossover passage to warm incoming fuel/air mixture, plus EGR mounting boss and PCV inlet.

EXHAUST MANIFOLDS: All exhaust manifolds are made of nodular cast iron for strength and high temperatures. All naturally aspirated engines exit exhaust gasses through a machined, articulated joint connection to the exhaust pipe. All manifolds intermesh with the intake manifold at the cylinder head.

2.5L engines use a four branch design with cylinders one and four joined and cylinder two and three joined to exit at the outlet.

ENGINE LUBRICATION: System is full flow filtration, pressure feed type. The oil pump is mounted within the crankcase and driven by the auxiliary shaft. Pressurized oil is routed through the main oil gallery, to the main and rod bearings, then to the lower balance shaft assemblies. Pistons are lubricated from directed holes in connecting rod assemblies. Camshaft and valve mechanisms are lubricated from a full-length cylinder head oil gallery supplied from the crankcase main oil gallery.

ENGINE MOUNTS

REMOVAL AND INSTALLATION

RIGHT SIDE MOUNT

(1) Remove the right engine mount insulator vertical fasteners from frame rail.

(2) Remove the load on the engine motor mounts by carefully supporting the engine and transmission assembly with a floor jack.

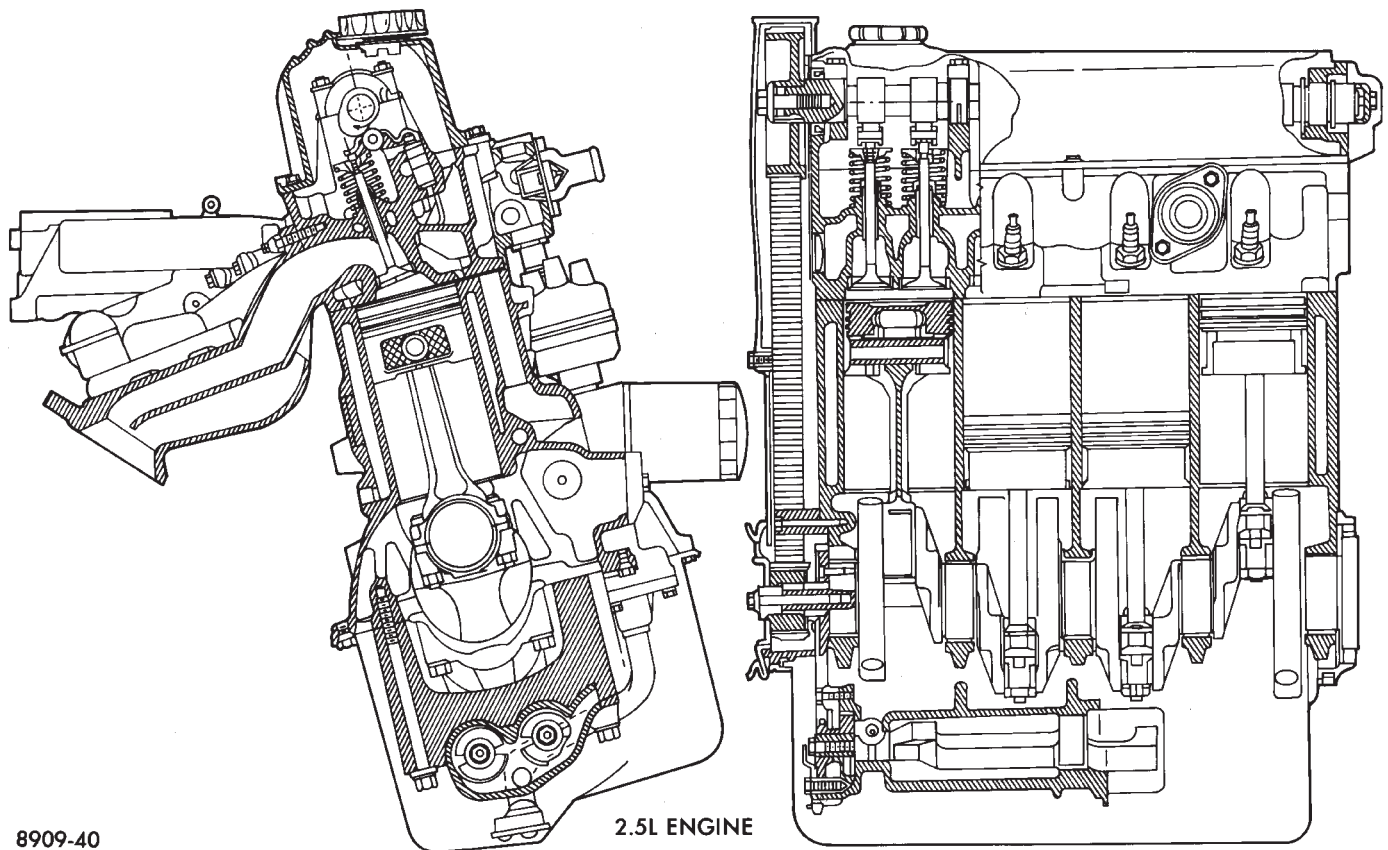

8909-40

Fig. 2 Engine

(3) Remove the thru bolt from the insulator assembly. Remove insulator.

(4) Reverse removal procedure for installation. Refer to (Fig. 3) for bolt tightening specifications.

(5) Engine mount adjustment, Refer to Engine Mount Insulator Adjustment of this section.

FRONT MOUNT

(1) Support the engine and transmission assembly with a floor jack so it will not rotate.

(2) Remove the thru bolt from the insulator and front crossmember mounting bracket.

(3) Remove the front engine mount bracket to front crossmember screws and nuts. Remove the insulator assembly.

(4) Reverse removal procedure for installation. Refer to (Fig. 3) for bolt tightening specifications.

(5) Engine mount adjustment, Refer to Engine Mount Insulator Adjustment of this section.

LEFT SIDE MOUNT

(1) Raise vehicle on hoist and remove left front wheel.

(2) Remove inter splash shield.

(3) Support the transmission with a transmission jack.

(4) Remove the insulator thru bolt from the mount.

(5) Remove the transmission mount fasteners and remove mount.

(6) Reverse removal procedure for installation. Refer to (Fig. 3) for bolt tightening specifications.

(7) Engine mount adjustment, Refer to Engine Mount Insulator Adjustment of this section.

ENGINE MOUNT RUBBER INSULATORS

Insulator location on frame rail (right side) and transmission bracket (left side) are adjustable to allow right/left drive train adjustment in relation to drive shaft assembly length.

Check and reposition right engine mount insulator (left engine mount insulator is floating type and will adjust automatically (Fig. 4). Adjust drive train position, if required, for the following conditions:

- Drive shaft distress: See Driveshafts in Suspension, Group 2.
- Any front end structural damage (after repair).
- Insulator replacement.

ENGINE MOUNT INSULATOR ADJUSTMENT

(1) Remove the load on the engine motor mounts by carefully supporting the engine and transmission assembly with a floor jack.

(2) Loosen the right engine mount insulator vertical fasteners, and the front engine mount bracket to front crossmember screws and nuts.

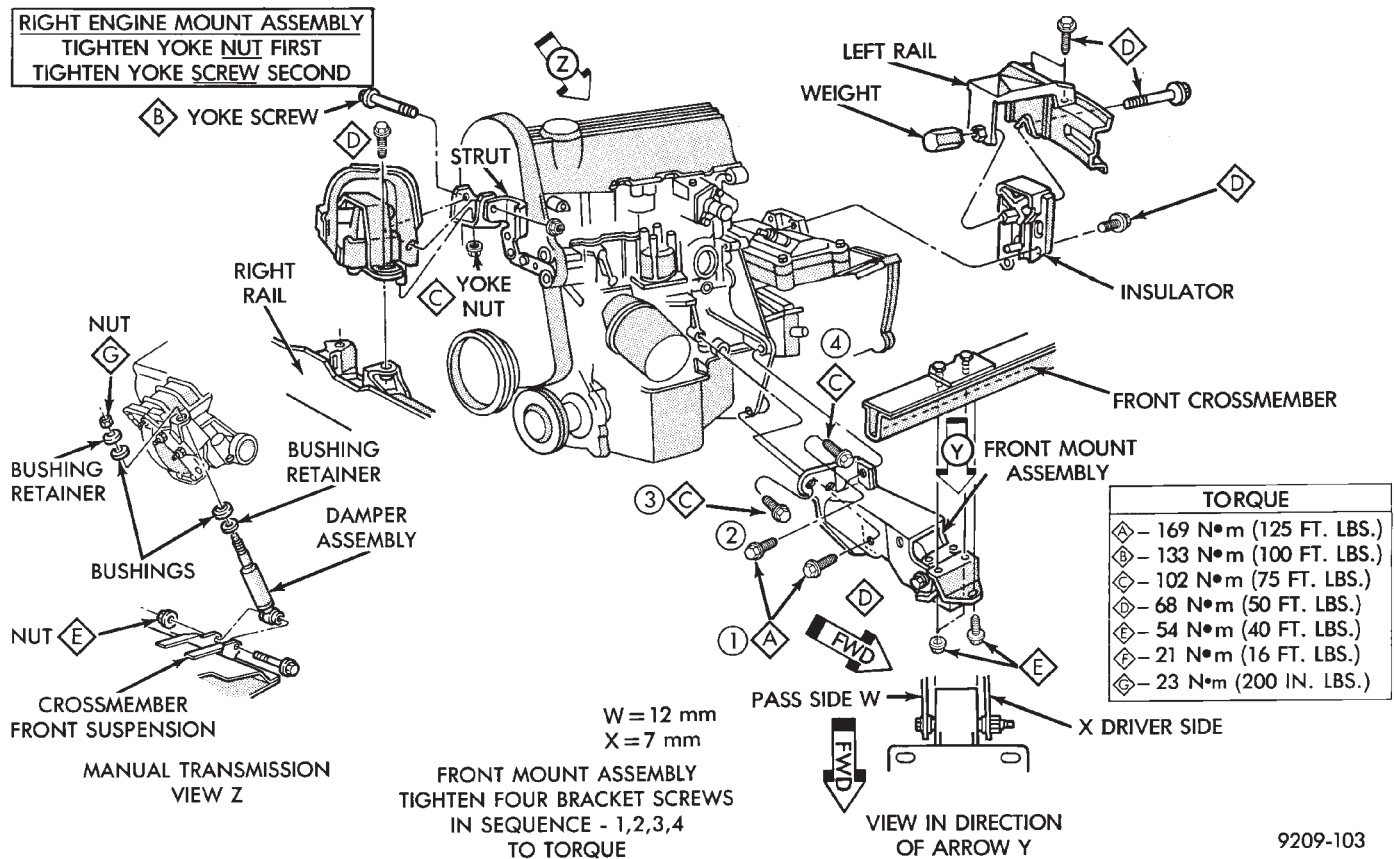

Fig. 3 Engine Mounting

Left engine mount insulator is sleeved over shaft and long support bolt to provide lateral movement adjustment with engine weight removed or not.

(3) Pry the engine right or left as required to achieve the proper drive shaft assembly length. See Drive Shaft in Suspension Group 2 for driveshaft identification and related assembly length measuring.

(4) Tighten right engine mount insulator vertical bolts to 37 N•m (27 ft. lbs.). Then tighten front engine mount screws and nuts to 54 N•m (40 ft. lbs.) and center left engine mount insulator.

(5) Recheck drive shaft length.

ENGINE ASSEMBLY

REMOVAL

- (1) Disconnect battery.
- (2) Scribe hood hinge outline on hood and remove hood.
- (3) Drain cooling system. Refer to Group 7 Cooling System for procedure.
- (4) Remove hoses from radiator and engine.
- (5) Remove radiator and fan assembly (Fig. 5).
- (6) Remove air cleaner and hoses.
- (7) Remove air conditioning compressor mounting bolts and set compressor aside (if so equipped).

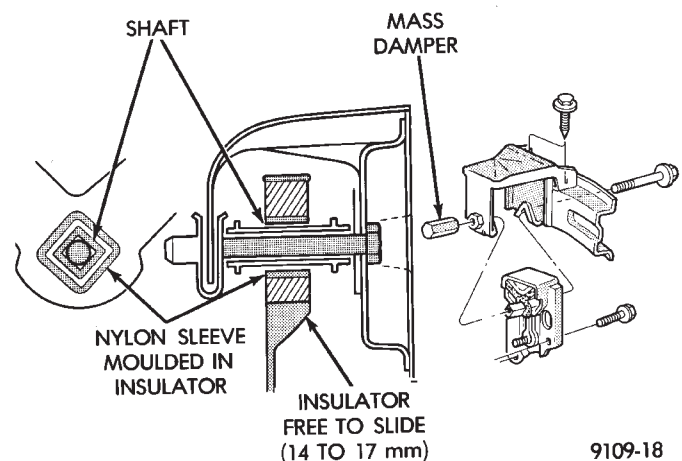

Fig. 4 Left Insulator Movement

- (8) Remove power steering pump mounting bolts and set pump aside.
- (9) Remove oil filter.
- (10) Disconnect fuel line, heater hose and accelerator cable.
- (11) Remove alternator mounting bolts and set alternator aside.
- (12) Disconnect all electrical connections from throttle body, and engine.
- (13) **Manual Transmission**
 - (a) Disconnect clutch cable.

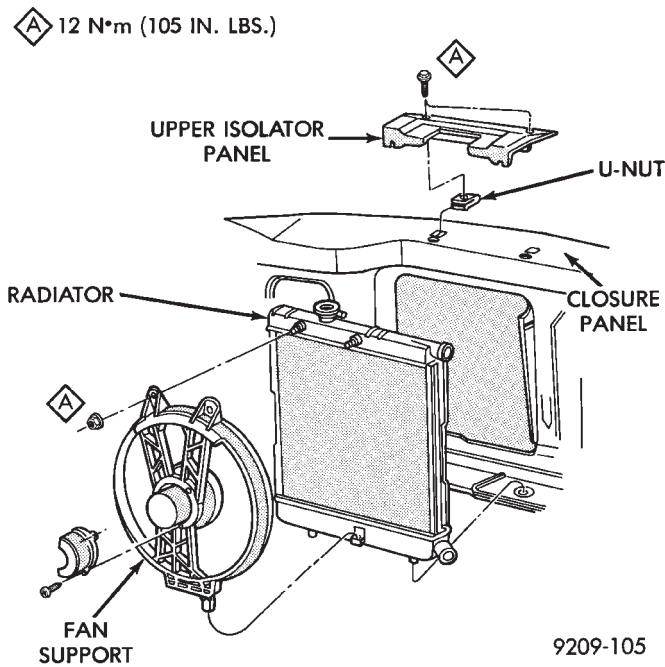

Fig. 5 Radiator and Fan Assembly

- (b) Remove transmission case lower cover.
- (c) Disconnect exhaust pipe at manifold.
- (d) Disconnect starter and lay aside.
- (e) Install transmission holding fixture.
- (14) **Automatic Transmission**
 - (a) Disconnect exhaust pipe at manifold.
 - (b) Disconnect starter and lay aside.
 - (c) Remove transmission case lower cover.
 - (d) Mark flex plate to torque converter.
 - (e) Remove screws holding torque converter to flex plate.
- (15) Attach C-clamp on front bottom of torque converter housing to prevent torque converter from coming out.
- (16) Install transmission holding fixture.
- (17) Remove right inner splash shield (Fig. 6).
- (18) Remove ground strap.
- (19) To **lower** engine, separate right engine bracket from yoke bracket To **raise** engine, remove long bolt through yoke and insulator. IF INSULATOR TO RAIL SCREWS ARE TO BE REMOVED, MARK INSULATOR POSITION ON SIDE RAIL TO INSURE EXACT REINSTALLATION (Fig. 3).
- (20) Remove transmission case to cylinder block mounting screws.
- (21) Remove front engine mount screw and nut.
- (22) Remove left insulator through bolt (from inside wheelhouse) or insulator bracket to transmission screws.
- (23) Remove engine from vehicle.

INSTALLATION

- (1) Install hoist to the engine and lower engine into the engine compartment.

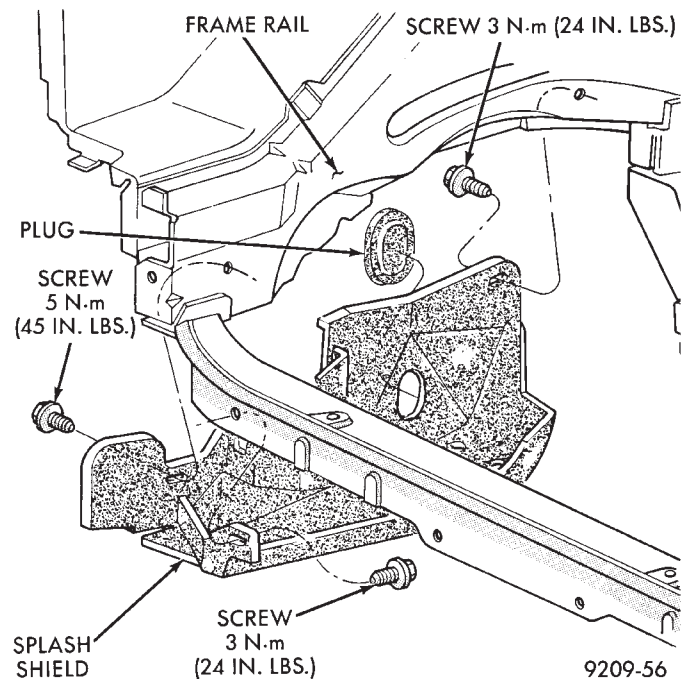

Fig. 6 Right Inner Splash Shield

SEE: ENGINE MOUNT RUBBER INSULATORS, THIS GROUP.

- (2) Align engine mounts and install but **do not tighten** until all mounting bolts have been installed. Tighten to 54 N·m (40 ft. lbs.).
- (3) Install transmission case to cylinder block mounting screws. Tighten to 95 N·m (70 ft. lbs.).
- (4) Remove engine hoist and transmission holding fixture.
- (5) Secure ground strap.
- (6) Install right inner splash shield.
- (7) Connect starter. See Electrical Group 8 for installation.
- (8) Connect exhaust system. See Exhaust Group 11 for installation.
- (9) **Manual Transmission** Install transmission case lower cover.
- (10) **Automatic Transmission** Remove C clamp from torque converter housing. Align flexplate to torque converter and install mounting screws. Tighten to 54 N·m (40 ft. lbs.).
- (11) **Manual Transmission** Connect clutch cable. See Clutch Group 6.
- (12) Install power steering pump (if equipped). Refer to Cooling System Group 7 for belt tension adjustment.
- (13) Install alternator. Refer to Cooling System Group 7 for belt installation.
- (14) Connect fuel line, heater hose, and accelerator cable.
- (15) Connect all electrical connections at alternator, throttle body and engine.
- (16) Install oil filter. Refill engine crankcase with proper oil to correct level.

(17) Reinstall air conditioning compressor (if equipped). See Heater and Air Conditioning, Group 24 for installation.

(18) Reinstall air cleaner and hoses.

(19) Reinstall radiator and shroud assembly. Install radiator hoses. Fill cooling system. Refer to Cooling System Group 7 for filling procedure.

(20) Install hood.

(21) Connect battery.

(22) Start engine and run until operating temperature is reached.

(23) Adjust transmission linkage if necessary.

SOLID MOUNT COMPRESSOR BRACKET SERVICE

When service procedures require solid mount bracket removal and installation for example: cylinder head removal, etc., it is important that bracket fasteners numbered 1 through 7 (Fig. 7) be removed and installed in sequence, as instructed in Removal and Installation.

ACCESSORIES REMOVAL

(1) Remove (and install/adjust) belts. Refer to Accessory Drive Belts in Cooling System, Group 7.

(2) Remove air conditioning compressor (in vehicle with lines and set aside) (Fig. 7).

(3) Remove alternator pivot bolt and remove alternator (in vehicle: turn wiring side up and disconnect, then rotate alternator, pulley end towards engine and remove).

(4) Remove air conditioner compressor belt idler.

SOLID MOUNT BRACKET—REMOVAL (FIG. 7)

(1) Remove right engine mount yoke screw. (Refer to Engine Mounts (Fig. 3) securing isolator support bracket to engine mount bracket.

(2) Remove five side mounting bolts #1, #4, #5, #6, and #7 (Fig. 7).

(3) Remove front mounting nut, #2, and remove (or loosen) front bolt #3*.

*In vehicle: fully loosen bolt and remove with assembly.

(4) Rotate solid mount bracket away from engine and slide on stud (#2 nut mounting stud) until free. Front mounting bolt and spacer will be removed with bracket.

SOLID MOUNT BRACKET—INSTALLATION

Front mounting bolt and spacer need to be installed simultaneously with bracket.

(1) Install bracket on front (#2 nut) mounting stud and slide bracket over timing belt cover into position.

(2) Loosen assembly bracket to engine fasteners (numbered #1 through #7 in Fig. 7).

CAUTION: Fasteners MUST BE TIGHTENED IN SEQUENCE and to specified torque as follows:

- (3)
 - First Bolt #1 to 30 N•m (30 in. lbs.)
 - Second Nut #2 and Bolt #3 to 54 N•m (40 ft. lbs.).
 - Third Bolts #1 (second tightening) #4 and #5 to 54 N•m (40 ft. lbs.).
 - Fourth Bolts #6 and #7 to 54 N•m (40 ft. lbs.).
- (4) Install alternator and compressor. Tighten compressor mounting bracket bolts to 54 N•m (40 ft. lbs.).

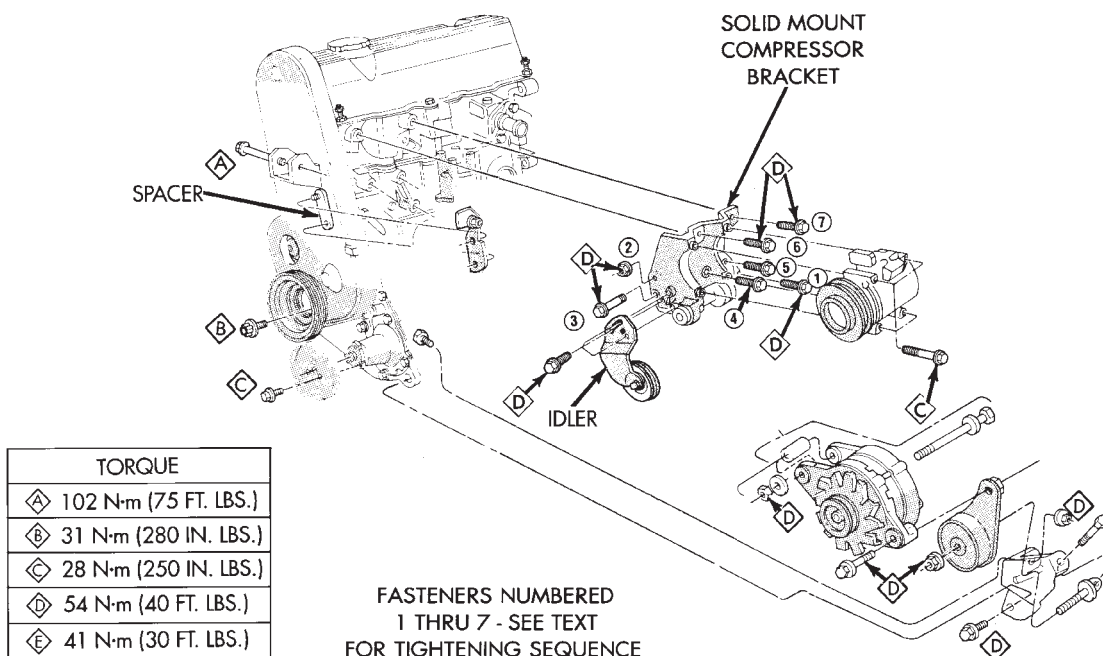

Fig. 7 Solid Mount Compressor Bracket 2.5L Engines



TIMING SYSTEM AND SEALS SERVICE

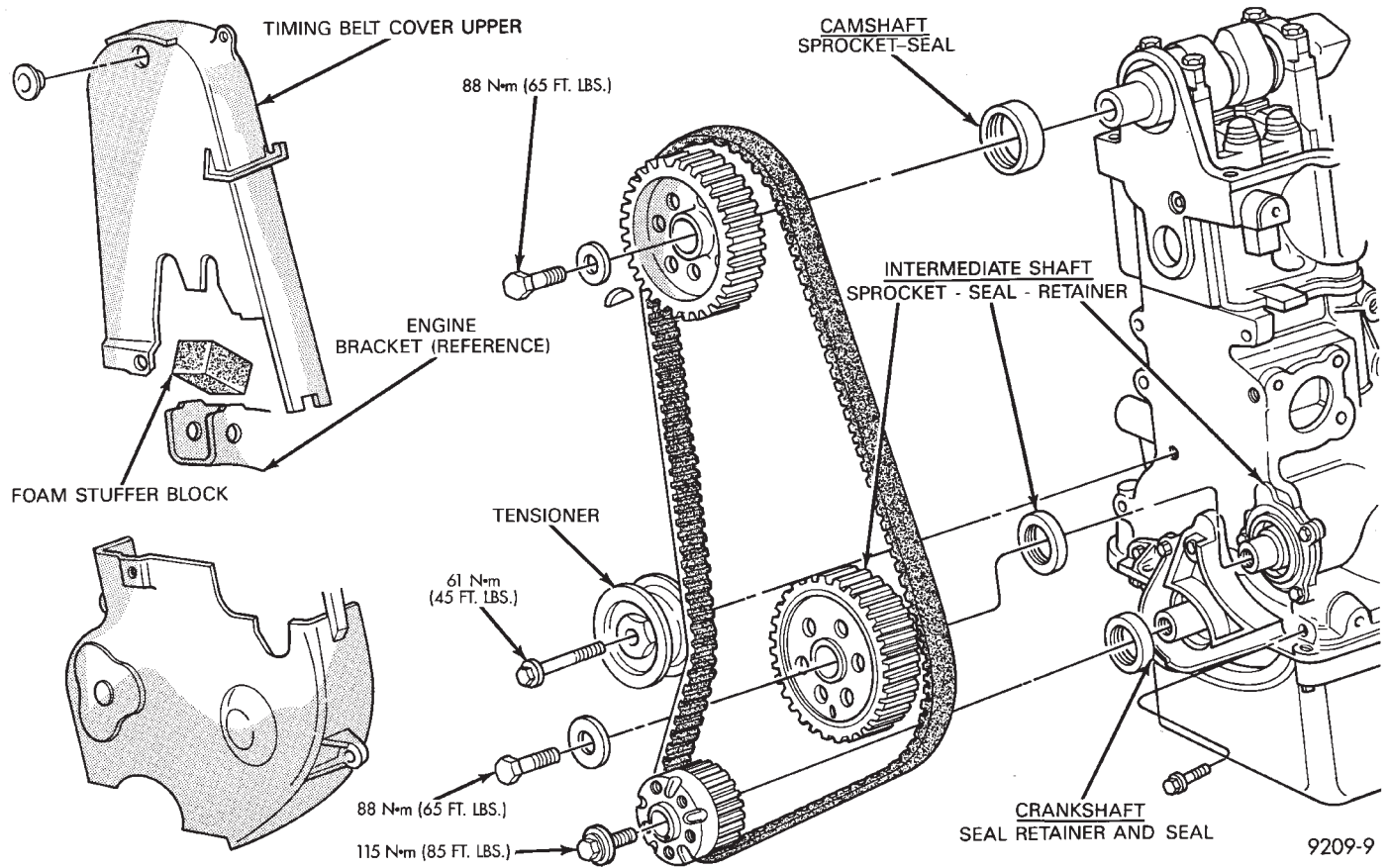

Fig. 1 Timing System and Seals

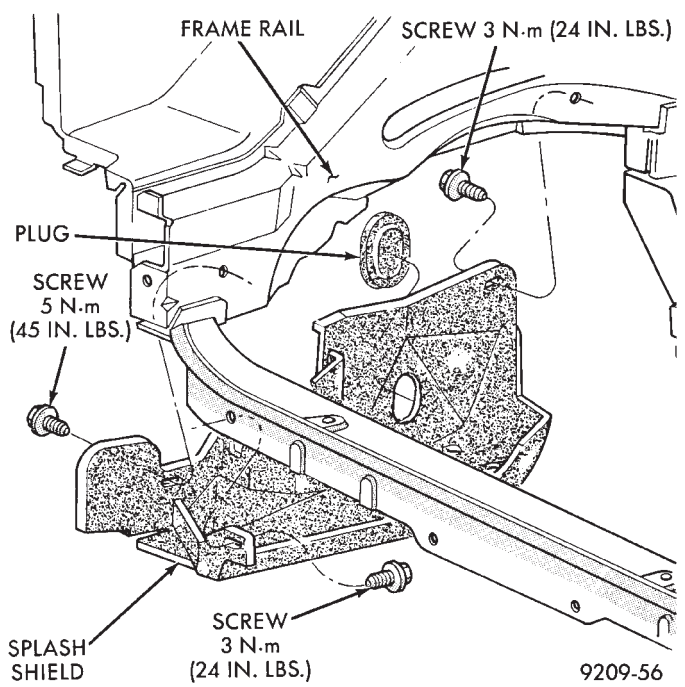

Fig. 2 Right Inner Splash Shield

Refer to (Fig. 1) for parts identification and torque specifications

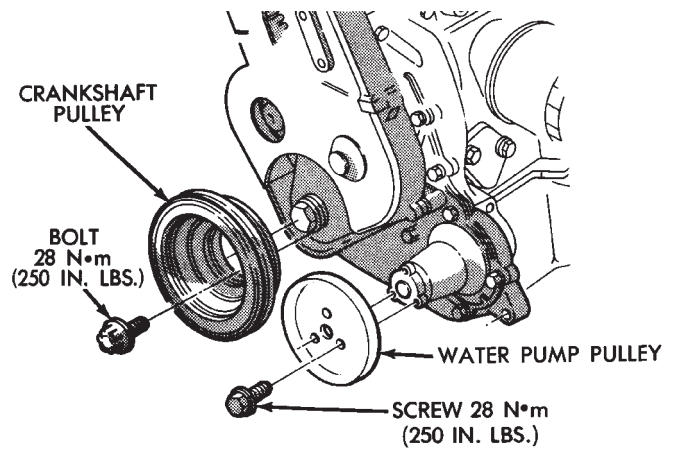

Fig. 3 Crankshaft and Water Pump Pulley

TIMING BELT SERVICE

- (1) Remove Solid Mount Compressor Bracket. Refer to procedure outlined in this section.
- (2) Raise vehicle on a hoist and remove right inner splash shield (Fig. 2).
- (3) Remove screws retaining water pump pulley and bolts retaining crankshaft pulley (Fig. 3) and lay pulley aside.
- (4) Remove nuts holding cover to cylinder head.

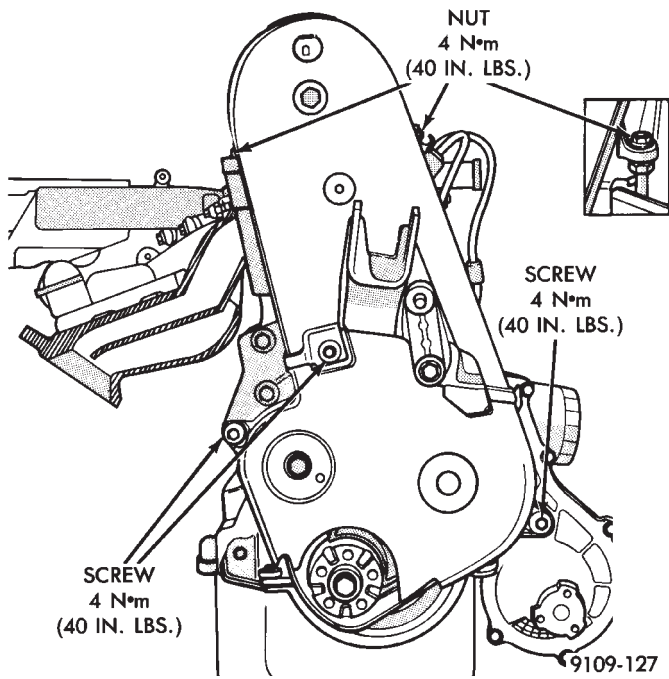

Fig. 4 Timing Belt Cover

- (5) Remove screws holding cover to cylinder block.
- (6) Remove both halves of timing belt cover and lay aside (Fig. 4)
- (7) Place a jack under engine.
- (8) Separate right engine mount (Fig. 5) and raise engine slightly.
- (9) Loosen timing belt tensioner screw (Fig. 6) and remove timing belt.

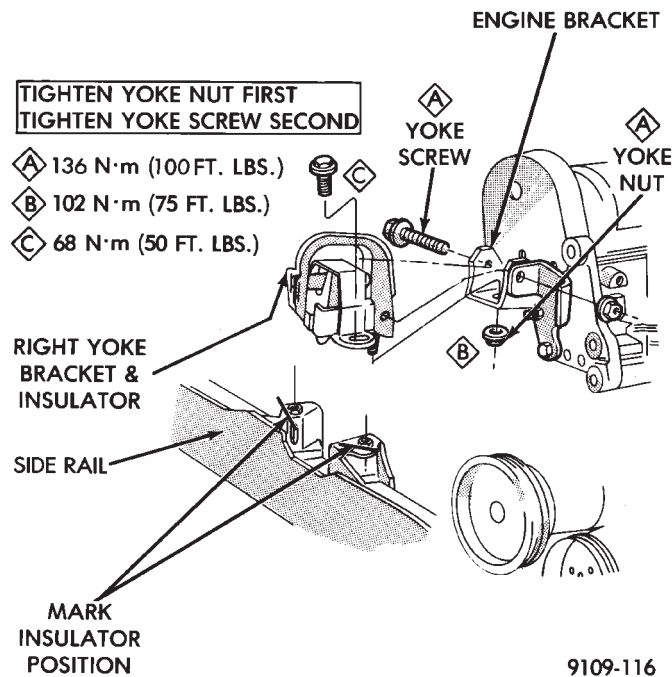

Fig. 5 Right Engine Mount

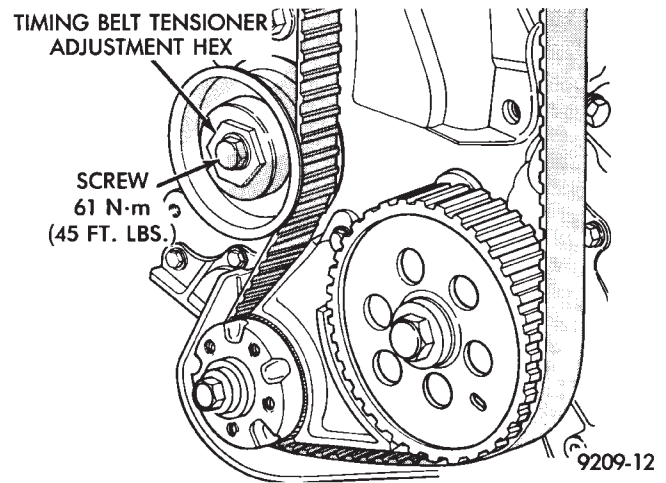

Fig. 6 Remove Timing Belt

SERVICING FRONT OIL SEALS—REPLACEMENT

- (1) With timing belt removed, remove crankshaft sprocket bolt.
- (2) Remove crankshaft sprocket using Special Tool C-4685, Insert and 5.9 inch long screw (Fig. 7).
- (3) Install crankshaft sprocket using plate L-4524, Thrust Bearing/washer and 5.9 inch long screw (Fig. 7).

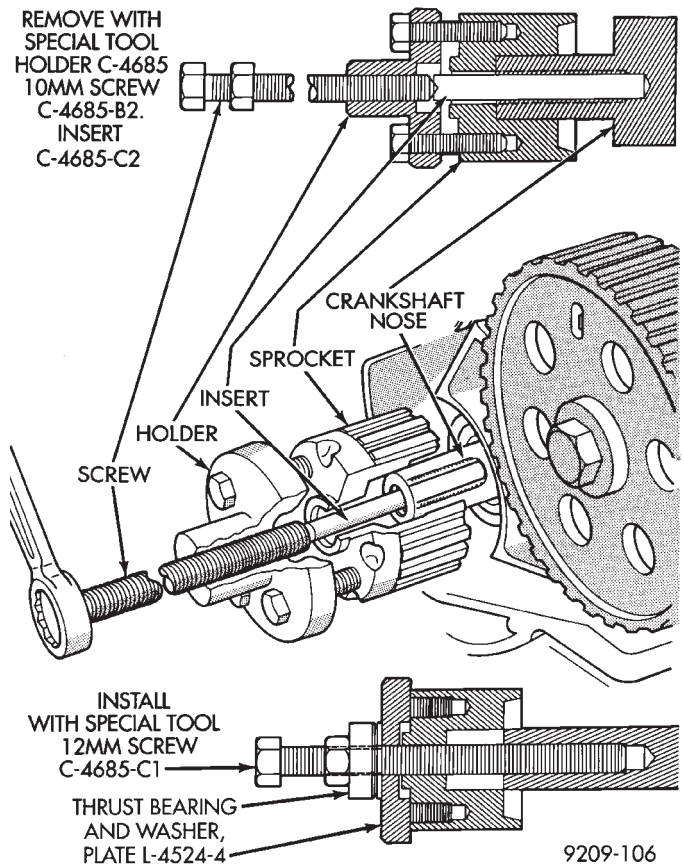
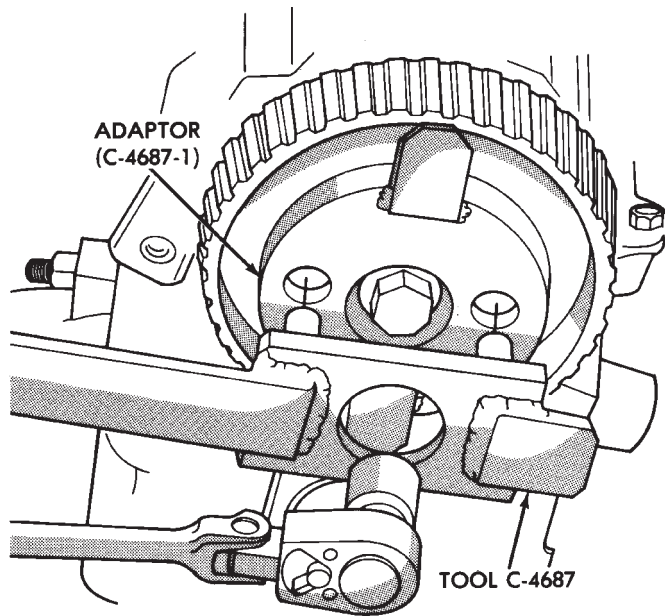

Fig. 7 Crankshaft Sprocket



8909-11

Fig. 8 Removing/Installing Camshaft or Intermediate Shaft Sprocket Screw

(4) Hold engine sprocket with Special Tool C-4687 (with adaptor Tool C-4687-1) while removing/installing screw (Fig. 8). The 2.5L Engine camshaft/intermediate shaft sprockets have an off-set hub and are identified with a six-hole pattern .

(5) Remove crankshaft seal using Special Tool 6341. Remove intermediate and camshaft seals using Special Tool C-4679 (Fig. 10).

CAUTION: Do not nick shaft seal surface or seal bore.

(6) Shaft seal lip surface must be free of varnish, dirt or nicks. Polish with 400 grit paper if necessary.

(7) Install engine crankshaft seal into retainer using Special Tool 6342 and 6343. Install Intermediate

and Camshaft seals using Special Tool C-4680. Install seals until flush (Fig. 10).

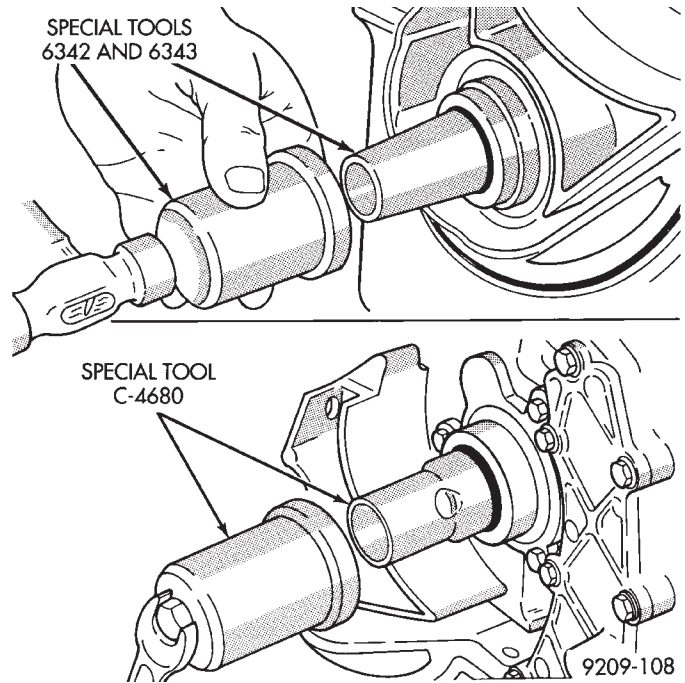

9209-108

Fig. 10 Installing Crankshaft, Intermediate Shaft, and Camshaft Seal

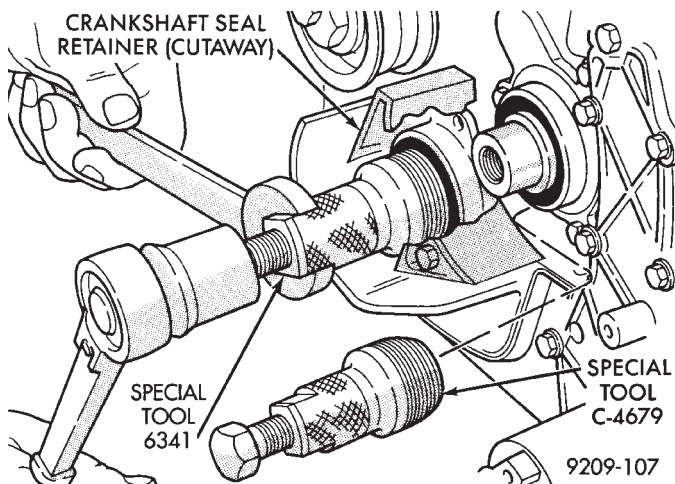

9209-107

Fig. 9 Removing Crankshaft, Intermediate Shaft and Camshaft Oil Seal

CAMSHAFT, CRANKSHAFT AND INTERMEDIATE SHAFTS TIMING PROCEDURE

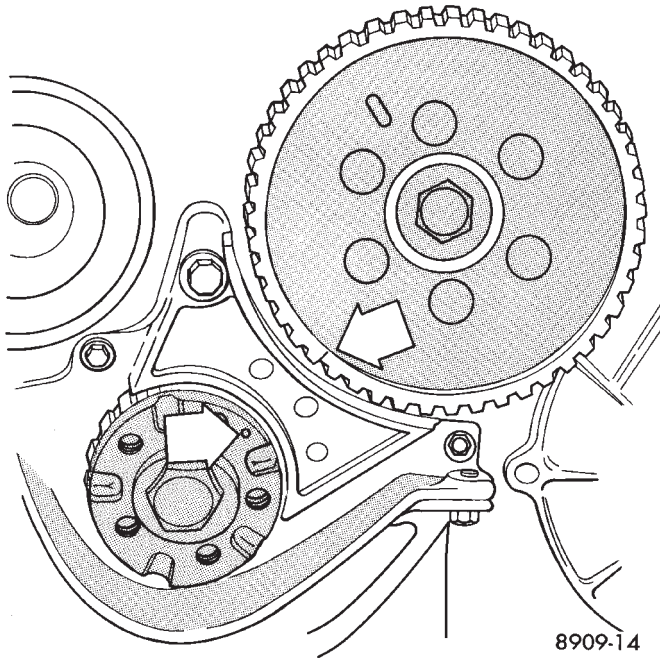

Fig. 11 Crankshaft and Intermediate Shaft Timing

- (1) Remove all spark plugs. Turn crankshaft and intermediate shaft until markings on sprockets are in line, see arrows (Fig. 11).
- (2) Turn camshaft until arrows on hub are in line with No. 1 camshaft cap to cylinder headline. Small hole (arrow Fig. 12) must be in vertical center line.
- (3) Install timing belt.

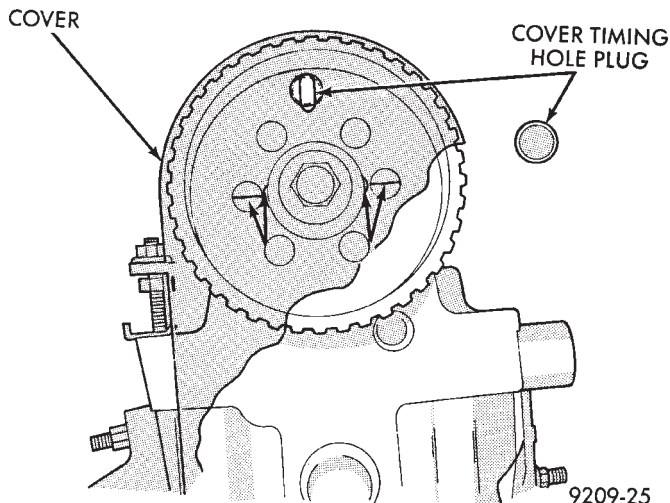

Fig. 12 Camshaft Timing

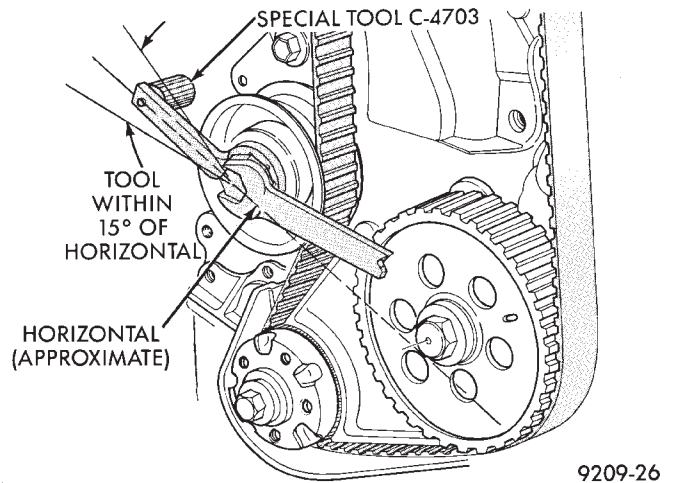

Fig. 13 Adjusting Drive Belt Tension

- (4) Rotate crankshaft two full revolutions and re-check timing.

CAUTION: Do not allow oil or solvents to contact the timing belt as they can deteriorate the rubber and cause tooth skipping.

- (5) Rotate crankshaft till number 1 cylinder is at the TDC position.
- (6) Put belt tension Special Tool C-4703 horizontally on large hex of timing belt tensioner pulley and loosen tensioner lock nut.
- (7) Reset belt tension Special Tool C-4703 index if necessary to have axis within 15° of horizontal.(Fig. 13)
- (8) Turn engine clockwise from TDC two crank revolutions to TDC. **Do not reverse rotate crankshaft or attempt to rotate engine using cam or accessory shaft attaching screw.**
- (9) Hold weighted wrench in position while tightening bolt on tensioner to 61 N•m (45 ft. lbs.) torque.
- (10) Lower engine onto engine mount install mounting bolts and tighten to specifications refer to (Fig. 3).
- (11) Remove jack from under engine.
- (12) Position both halves of timing belt cover together (Fig. 4).
- (13) Install fasteners holding cover to cylinder head and block. Tighten fasteners to 4 N•m (40 in. lbs.) torque.
- (14) Valve Timing Check; (timing belt cover installed). With number one cylinder at TDC, small hole in sprocket must be centered in timing belt cover hole (Fig. 12). If hole is not aligned correctly perform procedure again.
- (15) Install spark plugs.



CYLINDER HEAD AND VALVE ASSEMBLY SERVICE

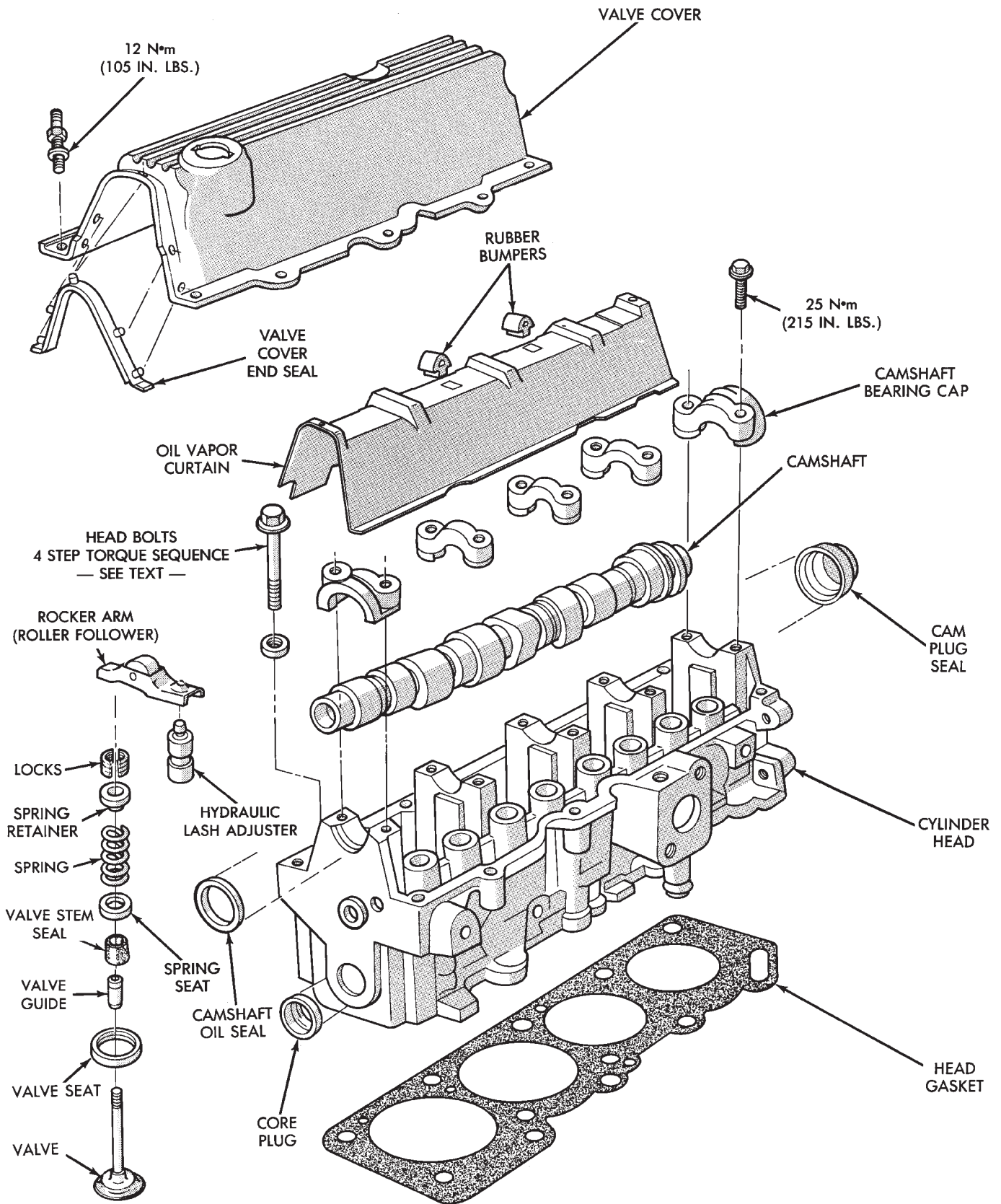

Fig. 1 Cylinder Head and Valve Assembly

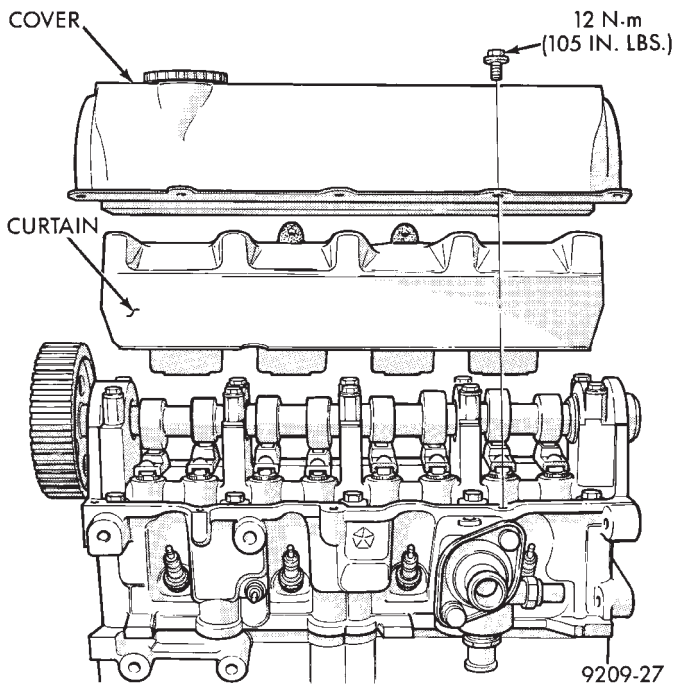

Fig. 2 Cylinder Head Cover and Curtain

CYLINDER HEAD COVER AND CURTAIN

A curtain aiding air/oil separation is installed on the cylinder head below the cylinder head cover (Figs. 1 and 2).

REMOVAL

- (1) Remove the cylinder head cover bolts (Fig. 2).
- (2) Remove cylinder head cover and curtain from cylinder head. Do not misplace the rubber bumpers on curtain.

CLEANING

Before installation, clean cylinder head and cover mating surfaces. Make certain the rails are flat.

CURTAIN INSTALLATION

Install curtain manifold side first with cutouts over cam towers and contacting cylinder head floor, then press opposite distributor side into position below cylinder head rail.

Curtain is retained in position with rubber bumpers (Fig. 1).

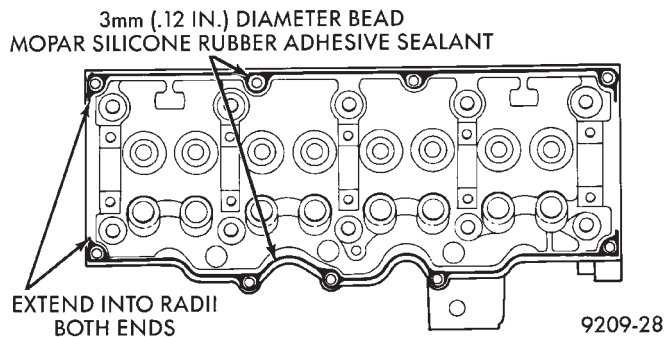

Fig. 3 Cylinder Head Valve Cover Rail Sealing

COVER SEALING AND INSTALLATION

Before installation, clean cylinder head and cover mating surfaces. Make certain rails are flat.

- (1) Install new end seals on valve cover.
- (2) Apply form-in-place Mopar Silicone Rubber Adhesive Sealant or equivalent gasket material to cylinder head cover rail (Fig. 3). Refer to procedure detailed in form-in-place gasket section of Standard Service Procedures, in this Group.

Caution: Do not allow oil or solvents to contact the timing belt as they can deteriorate the rubber and cause tooth skipping.

- (3) Install curtain, cover and end seal assembly to head and tighten to 12 N•m (105 in.lbs.) torque.

CYLINDER HEAD COMPONENTS—IN-VEHICLE SERVICE

Removal and installation of cylinder head or camshaft require separation of camshaft timing sprocket from camshaft. To maintain camshaft, intermediate shaft, and crankshaft timing during service procedures, the timing belt is left indexed on the sprocket while the assembly is suspended under light tension (Fig. 4).

CAUTION: Failure to maintain adequate tension on camshaft, intermediate, and crankshaft sprocket belt can result in lost engine timing. If timing is lost, refer to Timing System and Seals and (Fig. 4).

When removing the sprocket from the camshaft, you must maintain adequate tension on the sprocket

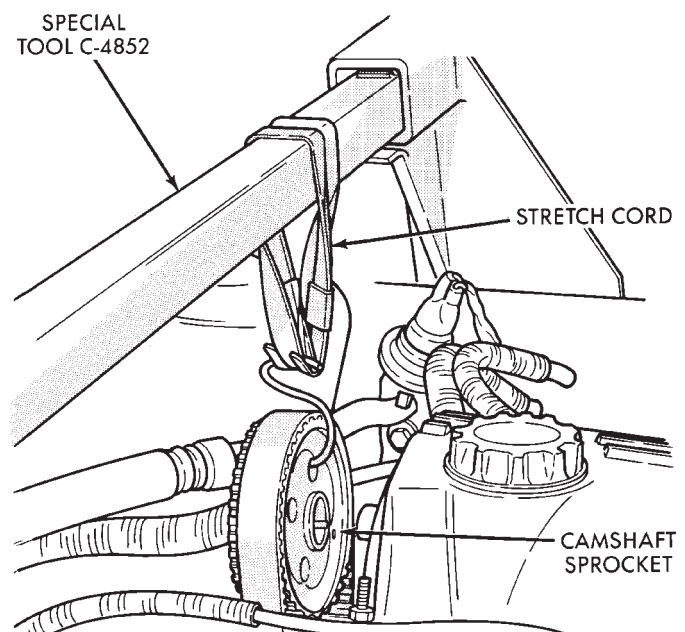

Fig. 4 Suspending Camshaft Sprocket

9209-29

and belt assembly to prevent the belt from disengaging with the intermediate or crankshaft timing sprockets. Refer to Timing System and Seals for removal and installation of camshaft sprocket procedure and to Camshaft Service for removal and installation of camshaft procedures.

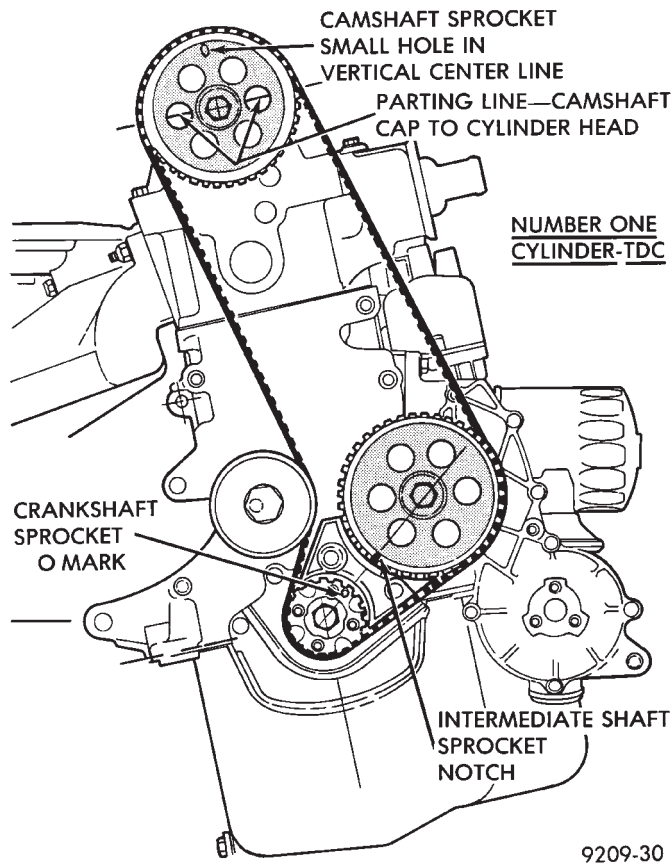

Fig. 5 Engine Sprocket Timing

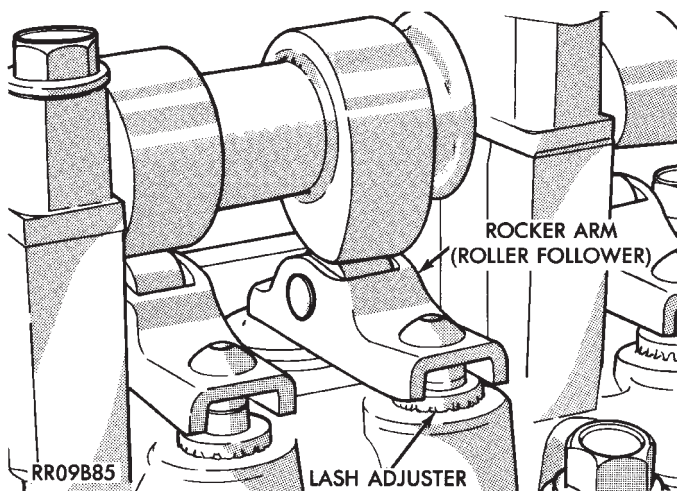

Fig. 6 Rocker Arm and Lash Adjuster

CAMSHAFT SERVICE

Refer to TIMING SYSTEM AND SEALS for camshaft timing belt and sprocket removal and installation, and CYLINDER HEAD In Vehicle Service.

REMOVAL

- (1) Remove the cylinder head cover and curtain.
- (2) Mark rocker arms for reinstallation in the same position (Fig. 6).
- (3) Loosen camshaft bearing cap screws several revolutions (Fig. 7).
- (4) Jar camshaft at rear of cam to loosen (break free) the bearing caps. **Use a soft faced mallet.**

CAUTION: Care should be exercised not to cock the camshaft during removal. Cocking of the camshaft could cause damage to the cam or bearing thrust surfaces.

- (5) Remove screws and caps such that cam does not cock.

INSPECTION

Check bearing cap and oil feed holes for blockage. Inspect bearing cap and cylinder head journals for wear and/or oversize, Refer to CYLINDER HEAD, **Inspect** and Specifications.

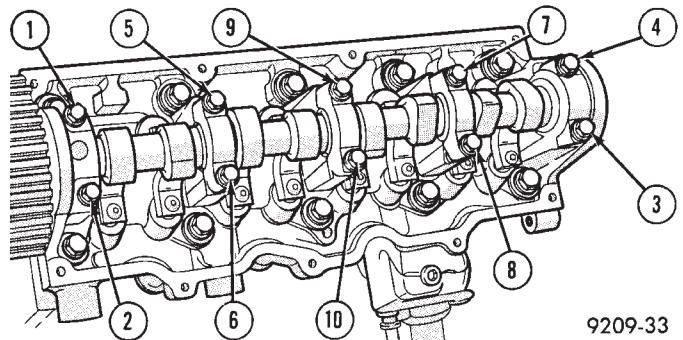

Fig. 7 Camshaft Cap Removal Sequence

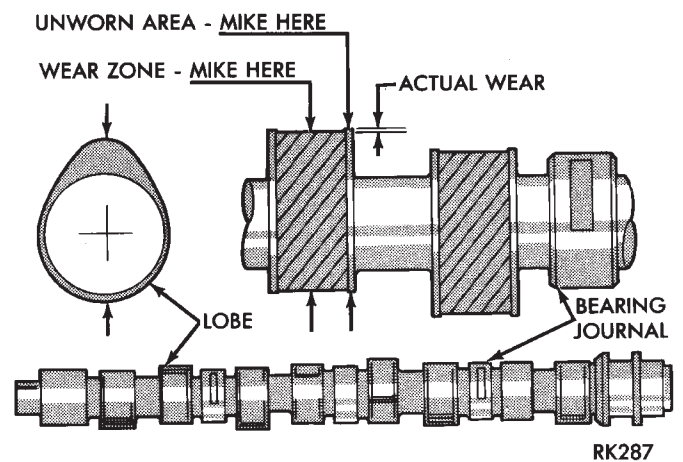

Fig. 8 Camshaft

Camshaft bearing journals and lobe wear. Lobe wear should not exceed .25mm (.010 inch). To measure cam lobe wear (Fig. 8), measure lobe diameter in two places at the largest diameter (over the nose). Take first reading with micrometer in unworn area

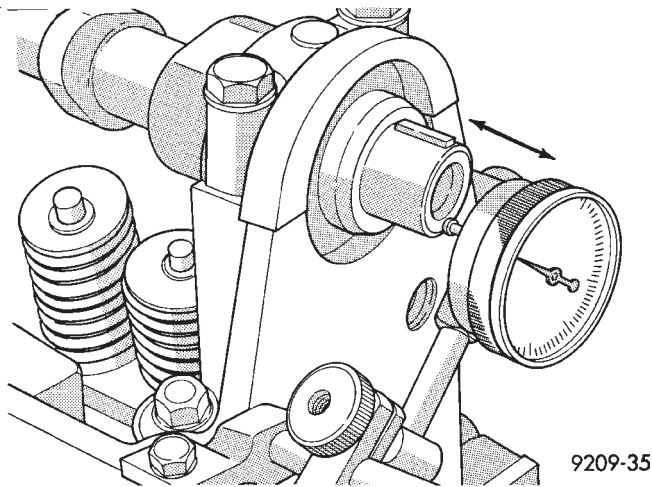

Fig. 9 Camshaft End Play

at the edge of the lobe. Take second reading in the worn area where rocker arm contacts the lobe. Subtract second reading from the first. The difference is the cam lobe wear.

CAMSHAFT END PLAY

- (1) Oil camshaft journals and install camshaft without cam followers. Tighten screws to specified torque.
- (2) Using a suitable tool, move camshaft as far rearward as it will go.
- (3) Zero dial indicator (Fig. 9).
- (4) Move camshaft as far forward as it will go.
- (5) End play travel: 0.13 - 0.33mm (0.005 - 0.013 inch).
- (6) Remove bearing caps and camshaft.

INSTALLATION

- (1) Install cam followers in correct order as removed.
- (2) Align camshaft bearing caps in proper sequence with Cap No. 1 at timing belt end and Cap No. 5 at transmission end. Arrows on Caps No. 1, 2, 3, 4 **must** point toward timing belt to prevent cap breakage (Fig. 10).
- (3) Apply Mopar Gasket Maker to No.1 and No.5 bearing cap (Fig. 11).
- (4) Caps must be installed before camshaft seals are installed.

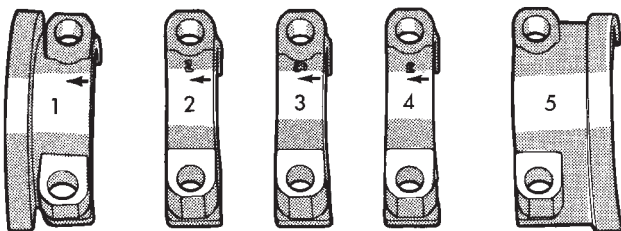

Fig. 10 Camshaft Bearing Caps Installation

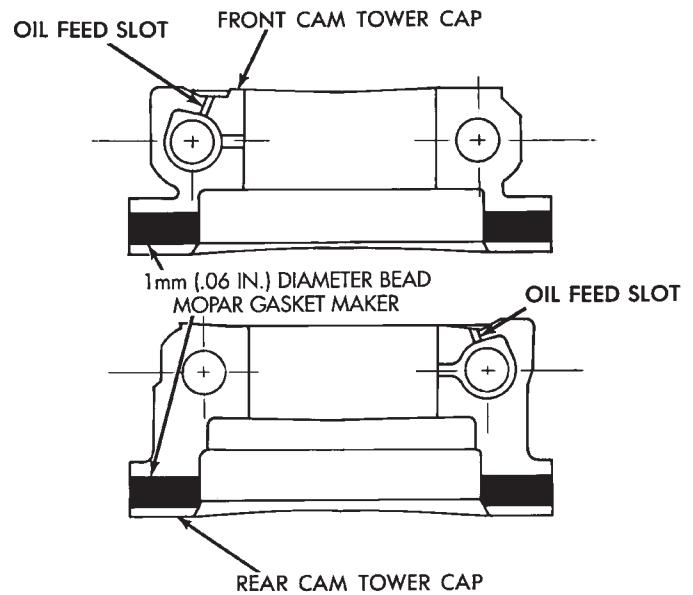

Fig. 11 Cam Tower Cap Sealing

LASH ADJUSTER (TAPPET) NOISE

A tappet-like noise may be produced from several items. Refer to Lash Adjuster and Tappet Noise - Diagnosis in Standard Service Procedures, this Group.

VALVE COMPONENTS REPLACE—CYLINDER HEAD NOT REMOVED

ROCKER ARM AND HYDRAULIC LASH ADJUSTER

REMOVAL

- (1) Remove valve cover.
- (2) For each rocker arm, rotate cam until base circle is in contact with rocker arm. Depress valve spring using Special Tool C-4682 (Fig. 12) and slide rocker arm out. Keep rocker arms in order for reassembly.
- (3) Remove hydraulic lash adjuster.

INSTALLATION

- (1) Install hydraulic lash adjusters making sure that adjusters are at least partially full of oil. This is indicated by little or no plunger travel when the lash adjuster is depressed.
- (2) Rotate cam until base circle is in contact position with rocker arm. Depress valve spring with Special Tool C-4682 (Fig. 12) and slide rocker arm in place. Keep rockers in order. It is possible for the valve spring retainer locks to become dislocated when depressing the valve spring. **Check and make sure the locks are in their proper location.**

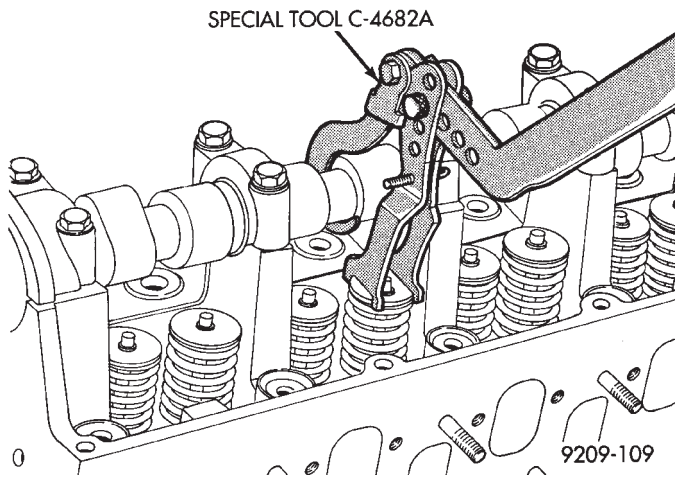

Fig. 12 Removing and Installing Valve Spring

(3) Install valve cover as previously outlined in this section.

VALVE SPRINGS AND VALVE STEM SEALS

REMOVAL

(1) Remove rocker arms as previously outlined in this section.

(2) Rotate crankshaft until piston is at TDC on compression.

(3) With air hose attached to adapter tool installed in spark plug hole, apply 90-120 psi air pressure.

(4) Using Special Tool C-4682 (Fig. 12) compress valve springs and remove valve locks.

(5) Remove valve spring.

(6) Remove valve stem seal by gently prying side-to-side with a screwdriver blade. Once dislodged from guide post, seal may be easily removed.

INSTALLATION

(1) Install valve seals (Fig. 13) as outlined in step (2) of **Valve Gear Reassembly - After Valve Service** in this section.

(2) Using Special Tool C-4682 compress valve springs only enough to install locks. Correct alignment of tool is necessary to avoid nicking valve stems (air pressure required), piston at TDC.

(3) Install rocker arms as previously outlined in this section.

CYLINDER HEAD

REMOVAL

(1) Perform fuel system pressure release procedure **before attempting any repairs**. Refer to Fuel System Group 14.

(2) Disconnect negative battery cable. Drain cooling system. Refer to Cooling System, Group 7.

(3) Remove air cleaner and disconnect all vacuum lines, electrical wiring and fuel lines from throttle body.

(4) Remove throttle linkage.

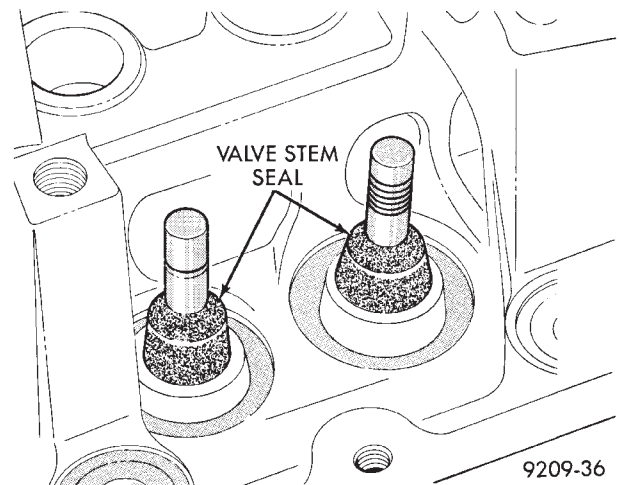

Fig. 13 Valve Stem Seals

- (5) Loosen power steering pump and remove belt.
- (6) Remove power brake vacuum hose from intake manifold.
- (7) Remove water hoses from water crossover.
- (8) Raise vehicle and remove exhaust pipe from manifold.
- (9) Remove power steering pump assembly and set aside.
- (10) Disconnect coil wiring connector and coil wire from coil.
- (11) Disconnect dipstick tube from thermostat housing and **ROTATE** bracket from stud. **DO NOT** bend the bracket.
- (12) Refer to Solid Mount Compressor Bracket removal in, this Group.
- (13) Remove cylinder head cover and curtain from head.
- (14) Remove cylinder head bolts.

INSPECT HEAD AND CAMSHAFT BEARING JOURNALS

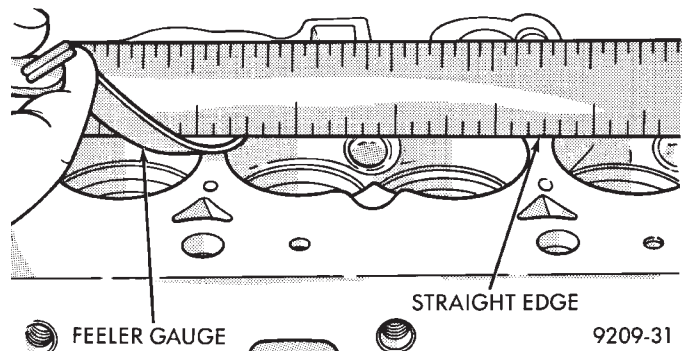

Fig. 14 Checking Cylinder Head Flatness

(1) Cylinder head must be flat within 0.1mm (.004 inch)(Fig. 14).

(2) Inspect camshaft journals for scoring and journal caps for oversize markings. When servicing cyl-

inder head or camshaft, it is necessary to be certain that oversized camshafts are used only in oversized heads. **Identify oversize components follows:**

Cylinder Head: Top of bearing caps painted **green** and O/SJ stamped rearward of oil gallery plug on end of head.

Camshaft: Barrel of camshaft painted **green** and O/SJ stamped on end of shaft.

CLEANING

Remove all gasket material from cylinder head and block. Be careful not gouge or scratch aluminum head sealing surface.

INSTALLATION

CAUTION: Head bolt diameter is 11mm. These bolts are identified with 11 on the head of the bolt. 10mm bolts will thread into the 11mm hole but will strip the cylinder block bolt hole.

Since the Cylinder head bolts are torqued using a new procedure they should be examined **BEFORE** reuse. If the threads are necked down the bolts should be replaced (Fig. 15).

Necking can be checked by holding a scale or straight edge against the threads. If all the threads do not contact the scale the bolt should be replaced.

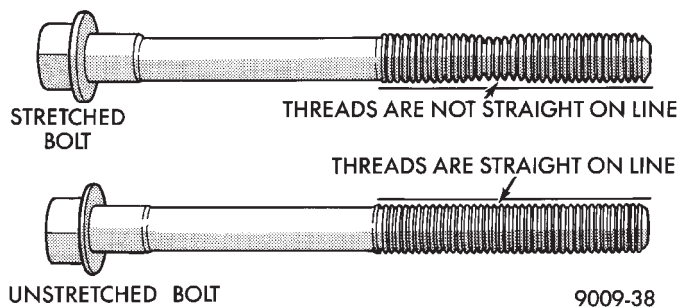

Fig. 15 Checking Bolts for Stretching (Necking)

- (1) Position new head gasket on the cylinder block.
- (2) Tighten the cylinder head bolts in the sequence shown in (Fig. 16). Using the 4 step torque turn method, tighten according to the following values:
 - First All to 61 N•m (45 ft. lbs.)
 - Second All to 88 N•m (65 ft. lbs.)
 - Third All (again) to 88 N•m (65 ft. lbs.)
 - Fourth + 1/4 Turn **Do use a not torque wrench for this step.**

Bolt torque after 1/4 turn should be over 90 ft. lbs. If not, replace the bolt.

- (3) Rotate dipstick tube on bracket.
- (4) Tighten bracket retaining nut to 23 N•m (200 in. lbs.).
- (5) Install cylinder head cover and curtain. Refer to cover sealing of this group for procedure.

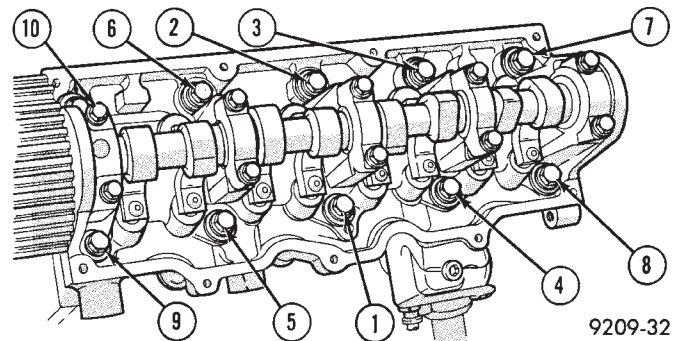

Fig. 16 Cylinder Head Tightening Sequence
VALVE SERVICE—CYLINDER HEAD REMOVED

VALVES AND VALVE SPRINGS

REMOVAL

- (1) With cylinder head removed, compress valve springs using Tool C-3422-B.
- (2) Remove valve retaining locks, valve spring retainers, valve stem seals and valve springs.
- (3) Before removing valves, **remove any burrs from valve stem lock grooves to prevent damage to the valve guides.** Identify valves to insure installation in original location.

VALVE INSPECTION

- (1) Clean valves thoroughly and discard burned, warped and cracked valves.
- (2) Measure valve stems for wear.
- (3) If valve stems are worn more than 0.05 mm (.002 inch.) replace valve.

VALVE GUIDES

- (1) Remove carbon and varnish deposits from inside of valve guides with a reliable guide cleaner.
- (2) Checking Valve Guide Wear:
 - Insert valve with valve head positioned 10 mm (.400 inch) above cylinder head gasket surface.
 - Move valve to and from the indicator (Fig. 17). The total dial indicator reading should not exceed the amount specified in (Fig. 18). Readings should be taken for lengthwise and crosswise (with respect to cylinder head) movement for each valve. Ream the guides for valves with oversize stems if dial indicator reading is excessive or if the stems are scuffed or scored.
 - (3) Service valves with oversize stems and oversize seals are available in 0.15mm, (.005 inch) 0.40mm, (.015 inch) and 0.80mm(.031 inch) oversize.

Oversize seals must be used with oversize valves.

Reamers sizes to accommodate the oversize valve stem are shown in (Fig. 18).

- (4) Slowly turn reamer by hand and clean guide thoroughly before installing new valve. **Do not attempt to ream the valve guides from standard**

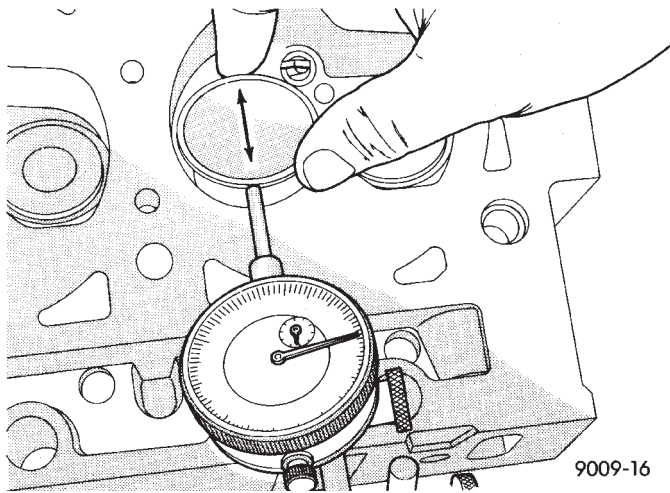

9009-16

Fig. 17 Checking Wear on Valve Guide—Typical

| | | |
|---|---------------------------------------|--|
| Valve Guide Dial Indicator Reading, Maximum | Intake Valve 0.5 mm (0.020 in.) | Exhaust Valve 0.7 mm (0.027 in.) |
| Valve Guide Reamer Oversize | Valve Guide Size | |
| 0.15 mm (.005 in.) | 8.125-8.150 mm (.3198-.3208 in.) | |
| 0.40 mm (.015 in.) | 8.375-8.400 mm (.3297-.3307 in.) | |
| 0.80 mm (.030 in.) | 8.775-8.800 mm (.3454-.3464 in.) | |

9109-8

Fig. 18 Valve Guide Specification

directly to 0.80mm (.030 inch). Use step procedure of 0.15mm (.005 inch), 0.40mm (.015 inch) and 0.80mm (.030 inch) so the valve guides may be reamed true in relation to the valve seat. After reaming guides, the seat runout should be measured and resurfaced if necessary. See Refacing Valves and Valve Seats.

Replace cylinder head if guide does not clean up with 0.80 mm (.030 inch) oversize reamer, or if guide is loose in cylinder head.

TESTING VALVE SPRINGS

(1) Whenever valves have been removed for inspection, reconditioning or replacement, valve springs should be tested. As an example, the compression length of the spring to be tested is 33.34mm (1-5/16 inches). Turn table of Tool C-647 until surface is in line with the 33.34mm (1-5/16 inch) mark on the threaded stud and the zero mark on the front. Place spring over stud on the table and lift compressing lever to set tone device (Fig. 19). Pull on torque wrench until ping is heard. Take reading on torque wrench at this instant. Multiply this reading by two. This will give the spring load at test length. Fractional measurements are indicated on the table for finer adjustments. Refer to

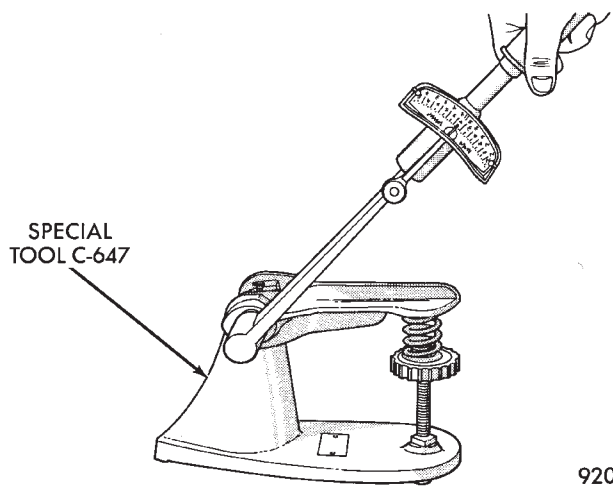

9209-37

Fig. 19 Testing Valve Spring with Special Tool C-647

specifications to obtain specified height and allowable tensions. Discard the springs that do not meet specifications.

(2) Inspect each valve spring for squareness with a steel square and surface plate, test springs from both ends. If the spring is more than 1.5mm (1/16 inch) out of square, install a new spring.

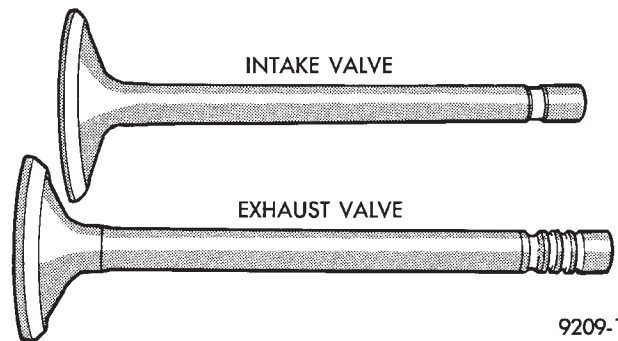

9209-14

Fig. 20 Intake and Exhaust Valves

| | |
|--------------------------------|-----------------------|
| Valve Dimensions | |
| Intake Valve (minimum) | |
| Stem diameter: | 7.935 mm (.3124 in.) |
| Face angle: | 45° |
| Valve margin: | .794 mm (.031 in.) |
| Head diameter: | 40.6 mm (1.60 in.) |
| Length: | 114.25 mm (4.498 in.) |
| Exhaust Valve (minimum) | |
| Stem diameter: | 7.881 mm (.3103 in.) |
| Face angle: | 44 1/2° |
| Valve margin: | 1.191 mm (.0469 in.) |
| Head diameter: | 35.4 mm (1.39 in.) |
| Length: | 114.87 mm (4.522 in.) |

9109-9

Fig. 21 Valve Dimensions

REFACING VALVES AND VALVE SEATS

(1) The intake and exhaust valve seats and valve face have a 45 degree angle.

(2) Inspect the remaining margin after the valves are refaced (Fig. 22). Exhaust valves with less than 1.191mm (3/64 inch) margin and intake valves with less than .794mm (1/32 inch) margin should be discarded.

(3) When refacing valve seats, it is important that the correct size valve guide pilot be used for reseating stones. A true and complete surface must be obtained.

(4) Measure the concentricity of valve seat using a valve seat dial indicator. Total runout should not exceed .051mm (.002 inch) (total indicator reading).

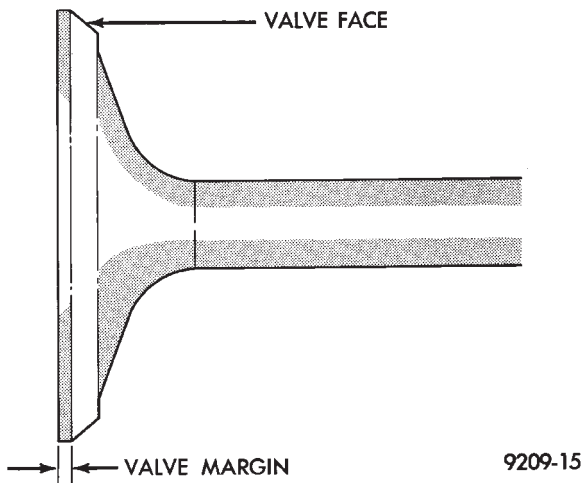

Fig. 22 Refacing Intake and Exhaust Valves

(5) Inspect the valve seat with Prussian blue to determine where the valve contacts the seat. To do this, coat valve seat **LIGHTLY** with Prussian blue then set valve in place. Rotate the valve with light pressure. If the blue is transferred to the center of valve face, contact is satisfactory. If the blue is transferred to top edge of the valve face, lower valve seat with a 15 degrees stone. If the blue is transferred to the bottom edge of valve face raise valve seat with a 65 degrees stone.

- Intake valve seat diameter 40.45mm (1.593 inch)
- Exhaust valve seat diameter 34.84mm (1.371 inch)

Valve seats which are worn or burned can be reworked, provided that correct angle and seat width are maintained. Otherwise cylinder head must be replaced.

(6) When seat is properly positioned the width of intake seats should be 1.75 to 2.25mm (0.69 to .088 inch) The width of the exhaust seats should be 1.50 to 2.00mm (.059 to .078 inch) (Fig. 23 Dimension 1).

(7) Check valve tip to valve spring seat dimensions after grinding to seats or faces. Grind valve tip to give 49.76 to 51.04mm (1.960 to 2.009 inch) over valve spring seat when installed in the head (Fig. 24). The valve tip diameter should be no less than 7.0mm (0.275

inch), if necessary, the tip chamfer should be reground to prevent seal damage when the valve is installed.

(8) Check the valve spring installed height after refacing the valve and seat (Fig. 25).

CAUTION: If more than .5mm (.020 inch) must be ground from the valve tip, check the clearance between the rocker arm and the valve spring retainer if below 1.25mm (.050 inch), grind the rocker arm ears according to the procedure described in Refacing Valves and Valve Seats.

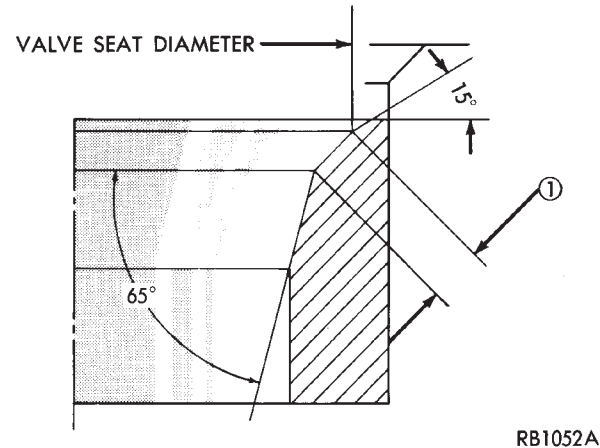

Fig. 23 Refacing Valve Seats

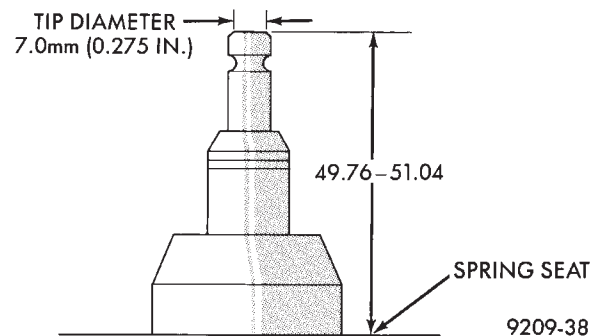

Fig. 24 Valve Tip to Valve Spring Seat Dimensions

CLEANING

Clean all valve guides, valves and valve spring assemblies thoroughly suitable cleaning solution before reassembling.

VALVE GEAR REASSEMBLY AFTER VALVE SERVICE

(1) Coat valve stems with lubrication oil and insert in cylinder head.

(2) Install new valve stem seals on all valves. The valve stem seals should be pushed firmly and squarely over valve guide. The lower edge of the seal should be resting on the valve guide boss.

CAUTION: When oversize valves are used, the corresponding oversize valve seal must also be used. Excessive guide wear may result if oversize seals are not used with oversize valves.

(3) Install valve spring seats and springs and retainers. Compress valve springs only enough to install locks, taking care not to misalign the direction of compression. Nicked valve stems may result from misalignment of the valve spring compressor.

CAUTION: When depressing the valve spring retainers with Special Tool C-3422-B the locks can become dislocated. Check to make sure both locks are in their correct location after removing tool.

(4) Check installed height of springs. Measurement is to be taken from the lower edge of the valve spring to its upper edge. Do not include the spring seat or retainer flange. Correct height is 41.2mm to 42.7mm (1.62 to 1.68 inches). If seats have been reground an additional spring seat may be required to maintain correct installed spring height.

(5) Install adjusters, rocker arms in order, and camshaft as previously described, see Camshaft-Install. Check for clearance between the projecting ears (either side of valve tip) of the rocker arms and the valve spring retainers. At least 1.25 mm (.050 inch) clearance must be present, if necessary, the rocker arm ears may be ground to obtain this clearance (Fig. 25).

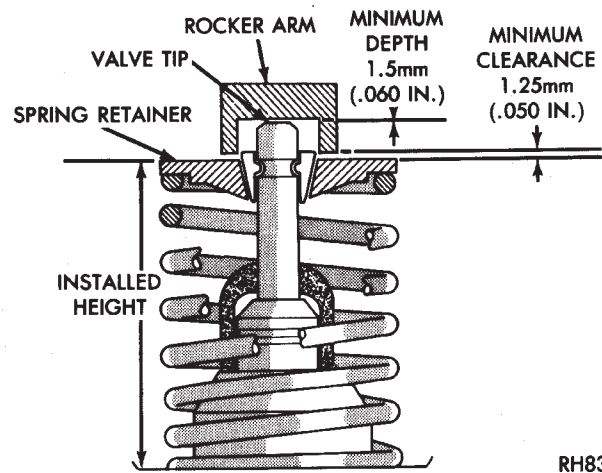

RH835B

Fig. 25 Checking Spring Installed Height and Spring Retainer Clearance

(6) Checking dry lash. Dry lash is the amount of clearance that exists between the base circle of an installed cam and the rocker arm roller when the adjuster is drained of oil and completely collapsed. Specified dry lash is 0.62 to 1.52 mm (.024 to .060 inch). To completely collapse adjuster for dry lash measurement, pry off retainer cap, disassemble, drain the adjuster of oil, reassemble, and install. After performing dry lash check, refill adjuster with oil (do not reuse retainer cap/s) and allow 10 minutes for adjuster/s to bleed down before rotating cam.



CYLINDER BLOCK, PISTON AND CONNECTING ROD ASSEMBLY SERVICE

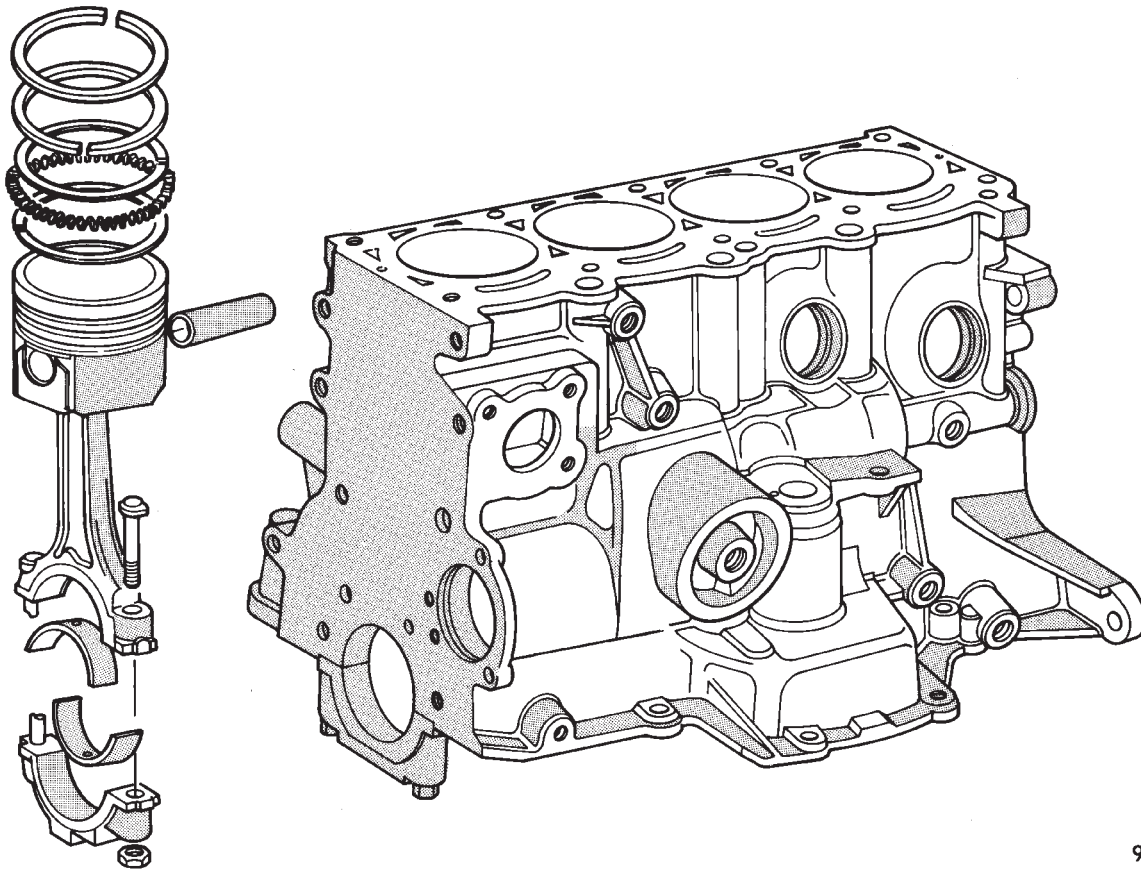

9109-131

Fig. 1 Cylinder Block, Piston and Connecting Rod Assembly

PISTON AND CONNECTING ROD—REMOVAL

(1) Remove top ridge of cylinder bores with a reliable ridge reamer before removing pistons from cylinder block. **Be sure to keep tops of pistons covered during this operation.** Mark piston with matching cylinder number (Fig. 2).

(4) Squirt hole on connecting rod must face timing belt end of engine.

(5) Pistons and connecting rods must be removed from top of cylinder block. Rotate crankshaft so that each connecting rod is centered in cylinder bore.

(6) Remove connecting rod cap. Install connecting rod bolt protectors on connecting rod bolts (Fig. 4). Push each piston and rod assembly out of cylinder bore.

Be careful not to nick crankshaft journals.

(7) After removal, install bearing cap on the mating rod.

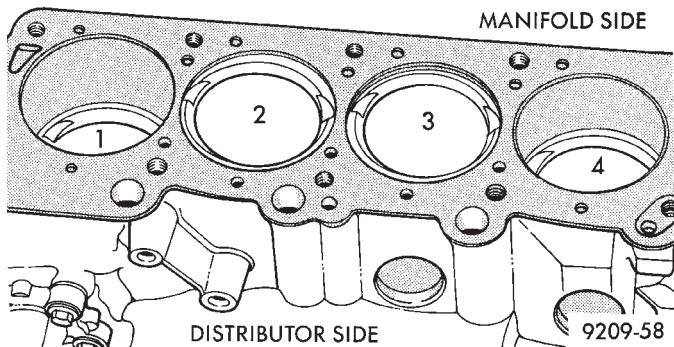
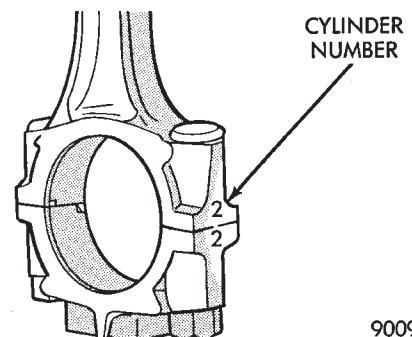

Fig. 2 Piston Marking

(2) Remove oil pan. Inspect connecting rods and connecting rod caps for cylinder identification. Identify them if necessary. (Fig. 3)

(3) Valve relief toward manifold side of engine.



9009-74

Fig. 3 Identify Connecting Rod to Cylinder

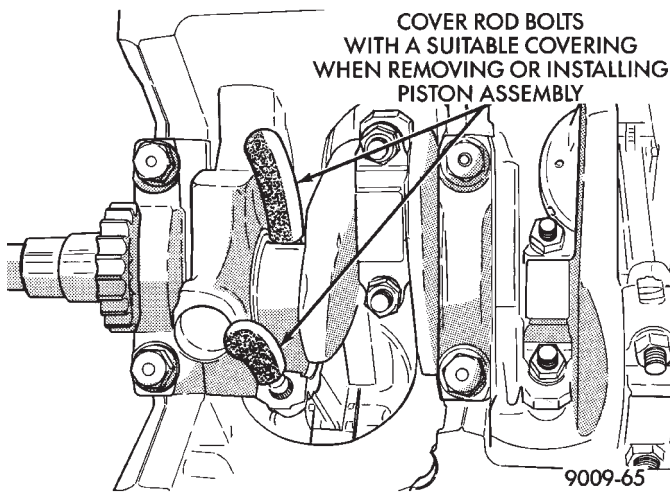

Fig. 4 Connecting Rod Protectors

CYLINDER BLOCK CLEANING AND INSPECTION

- (1) Clean cylinder block thoroughly and check all core hole plugs for evidence of leaking.
- (2) If new core plugs are installed, Refer to Engine Core Oil and Cam Plugs.
- (3) Examine block and cylinder bores for cracks or fractures.

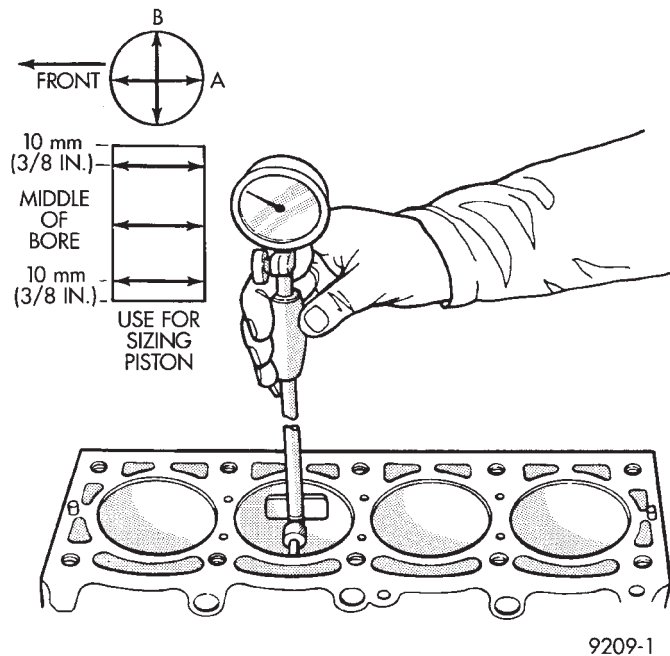

Fig. 5 Checking Cylinder Bore Size

CYLINDER BORE INSPECTION

The cylinder walls should be checked for out-of-round and taper with Tool C-119 (Fig. 5). If the cylinder walls are badly scuffed or scored, the cylinder block should be rebored and honed, and new pistons and rings fitted. Whatever type of boring equipment is used, boring and honing operation should be closely coordinated with the fitting of pistons and rings in order that specified clearances may be maintained.

Refer to Honing Cylinder Bores outlined in the Standard Service Procedures for specification and procedures.

Measure the cylinder bore at three levels in directions A and B (Fig. 5). Top measurement should be 10mm (3/8 inch) down and bottom measurement should be 10mm (3/8 inch.) up from bottom of bore. Refer to (Fig. 6) for specifications.

| Engine Type | Skirt Sizing Location ("SL")** | Piston to Cylinder Clearance (New Part) | Wear Limit |
|-------------|--------------------------------|---|----------------------|
| 2.5L TBI | 47.5mm (1.87 in.) | 0.025-0.050mm (0.0010-0.0020 in.) | 0.070mm (0.0027 in.) |

*Refer to Specifications for Available Piston Sizes
 **"SL" = Sizing Location

9109-119

Fig. 6 Piston Size Location and Clearance Chart

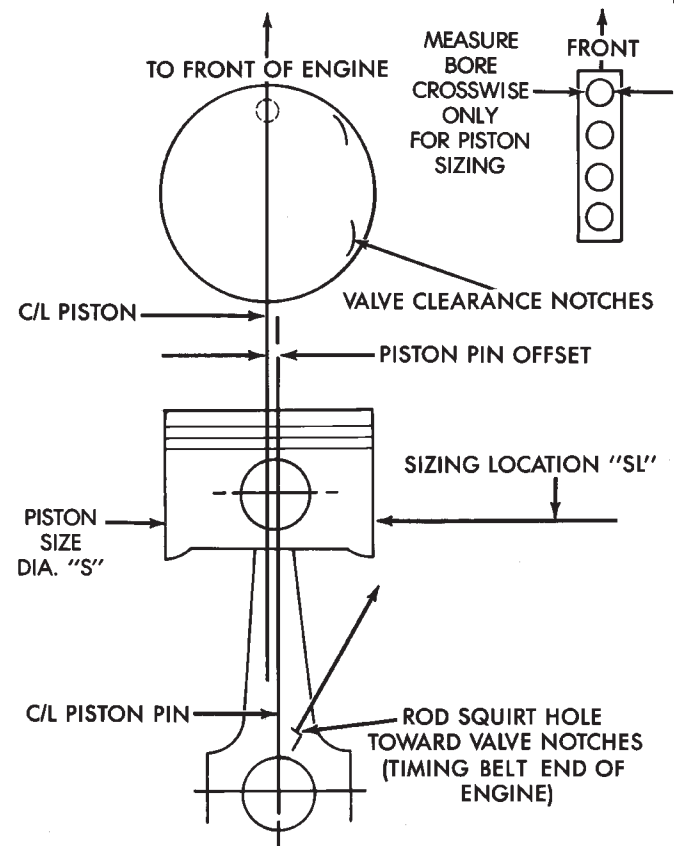

Fig. 7 Piston Installation and Sizing Information

SIZING PISTONS

Piston and cylinder wall must be clean and dry. Piston diameter should be measured 90 degrees to piston pin at size location shown in (Fig. 7). Cylinder bores should be measured halfway down the cylinder

bore and transverse to the engine crankshaft center line shown in (Fig. 5). Refer to (Fig. 6) for specifications.

Pistons and cylinder bores should be measured at normal room temperature, 70°F. (21°C).

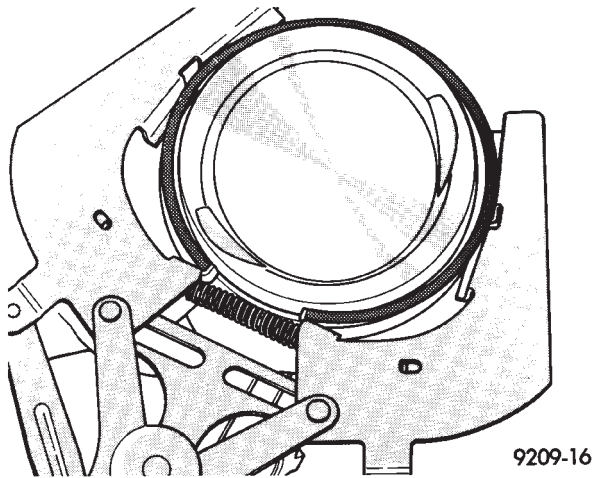

Fig. 8 Piston Rings—Removing and Installing

PISTON RING—REMOVAL

- (1) ID mark on face of upper and intermediate piston rings must point toward piston crown.
- (2) Using a suitable ring expander, remove upper and intermediate piston rings (Fig. 8).
- (3) Remove the upper oil ring side rail, lower oil ring side rail and then oil ring expander from piston.
- (4) Clean ring grooves of any carbon deposits.

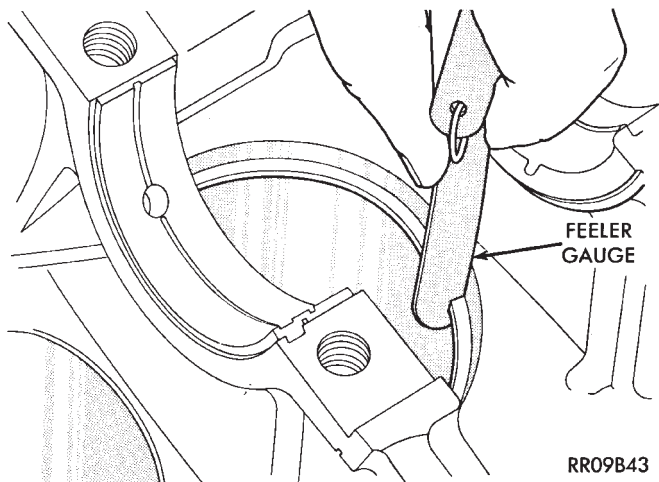

Fig. 9 Piston Ring Gap

FITTING RINGS

- (1) Wipe cylinder bore clean. Insert ring and push down with piston to ensure it is square in bore. The ring gap measurement must be made with the ring positioning at least 12mm (.50 inch) from bottom of cylinder bore. Check gap with feeler gauge (Fig. 9).

Refer to specifications (Fig. 12).

- (2) Check piston ring to groove clearance: (Fig. 10). Refer to specification (Fig. 12).

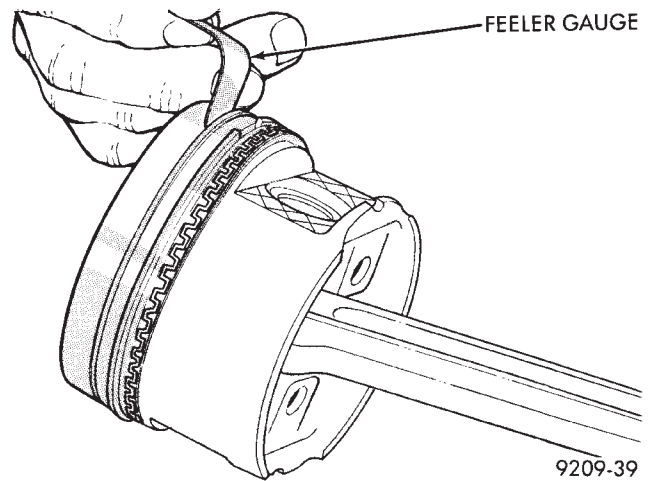

Fig. 10 Measuring Piston Ring Groove Clearance

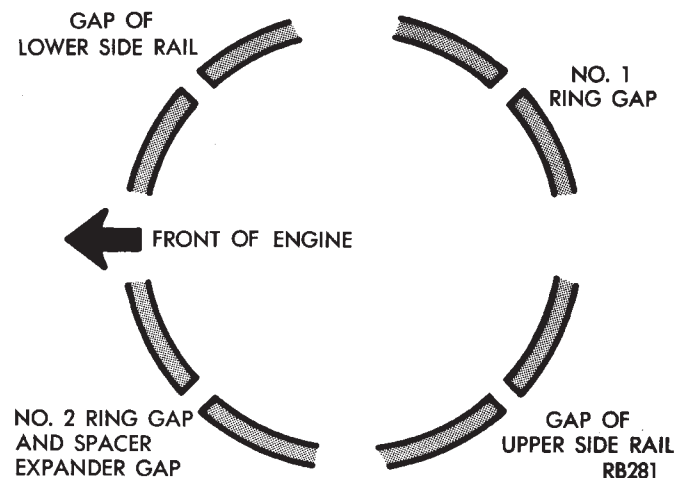

Fig. 11 Piston Ring End Gap Position

| Naturally Aspirated | Piston Groove Clearance | Wear Limit |
|------------------------------|---|-----------------------|
| (1) Upper Piston Ring | 0.038 to 0.078 mm (.0015 to .0031 in.) | 0.10 mm (.004 in.) |
| (2) Intermediate Piston Ring | 0.038 to 0.093 mm (.0015 to .0037 in.) | 0.10 mm (.004 in.) |
| (3) Oil Control Ring | Should be free in groove, not to exceed 0.2 mm (.008 in.) side clearance. | |
| Naturally Aspirated | Ring Gap | Wear Limit |
| Upper Ring | 0.25 to 0.51 mm (.010 to .020 in.) | 1.0 mm (.039 in.) |
| Intermediate Ring | 0.28 to 0.48 mm (.011 to .021 in.) | 1.0 mm (.039 in.) |
| Oil Control Ring | 0.38 to 1.40 mm (.015 to .055 in.) | 1.88 mm (.074 in.) |

9109-118

Fig. 12 Piston Ring Specifications

PISTON RINGS—INSTALLATION

- (1) The No. 1 and No. 2 piston rings have a different cross section. Install rings with manufacturers I.D. mark facing up, to the top of the piston (Fig. 11).

CAUTION: Install piston rings in the following order:

- (a) Oil ring expander.
 - (b) Upper oil ring side rail.
 - (c) Lower oil ring side rail.
 - (d) No. 2 Intermediate piston ring.
 - (e) No. 1 Upper piston ring.
- (2) Install the side rail by placing one end between the piston ring groove and the expander. Hold end firmly and press down the portion to be installed until side rail is in position. **Do not use a piston ring expander** (Fig. 13).
- (3) Install upper side rail first and then the lower side rail.
- (4) Install No. 2 piston ring and then No. 1 piston ring (Fig. 8).

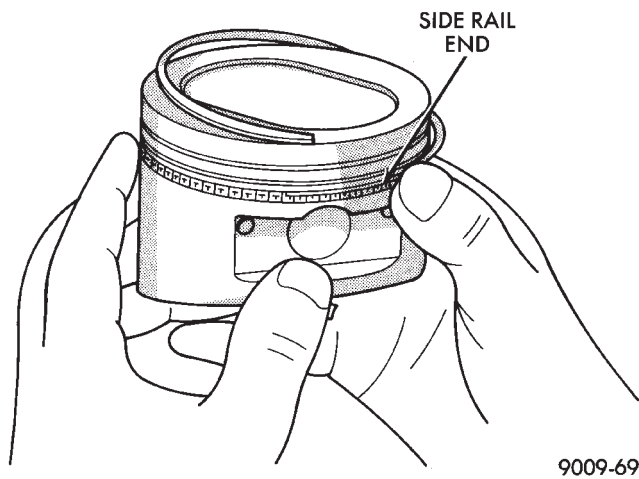

9009-69

Fig. 13 Installing Side Rail

- (5) Position piston ring end gaps as shown in (Fig. 14).
- (6) Position oil ring expander gap at least 45° from the side rail gaps but **not** on the piston pin center or on the thrust direction. Staggering ring gap is important for oil control.

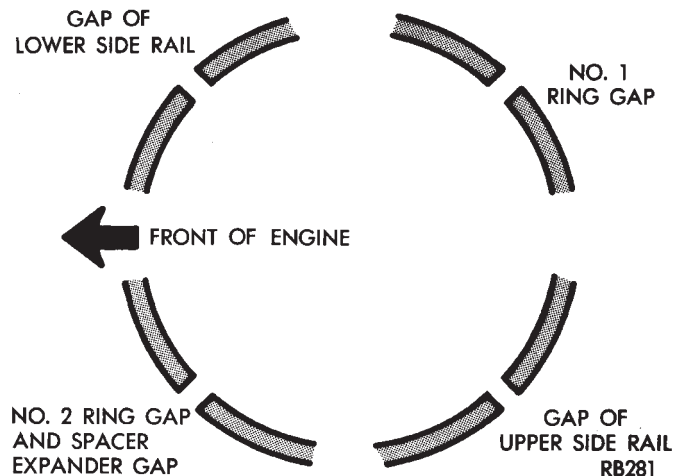

RB281

Fig. 14 Piston Ring End Gap Position

PISTON AND CONNECTING ROD ASSEMBLY INSTALLATION

- (1) Before installing pistons, and connecting rod assemblies into the bore, be sure that compression ring gaps are staggered so that neither is in line with oil ring rail gap.
- (2) Before installing the ring compressor, make sure the oil ring expander ends are butted and the rail gaps located as shown in (Fig. 14).

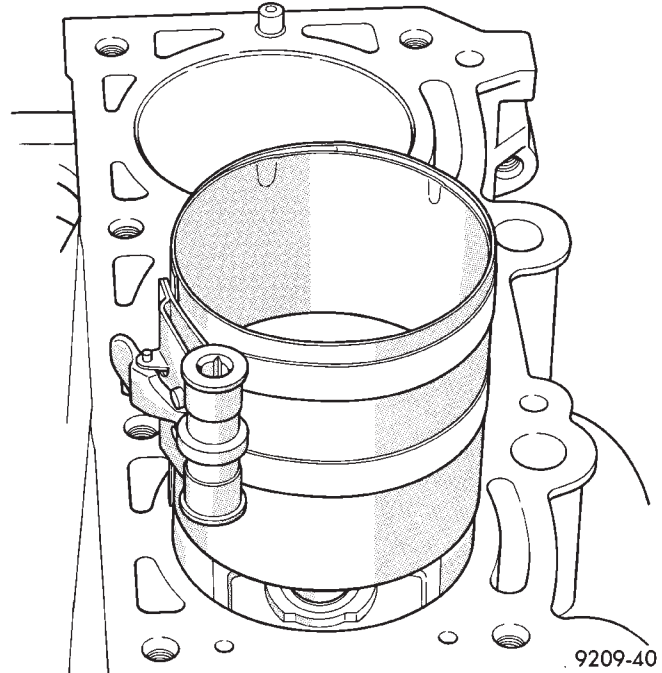

9209-40

Fig. 15 Installing Piston

- (3) Immerse the piston head and rings in clean engine oil, slide the ring compressor, over the piston and tighten with the special wrench. **Be sure position of rings does not change during this operation .**

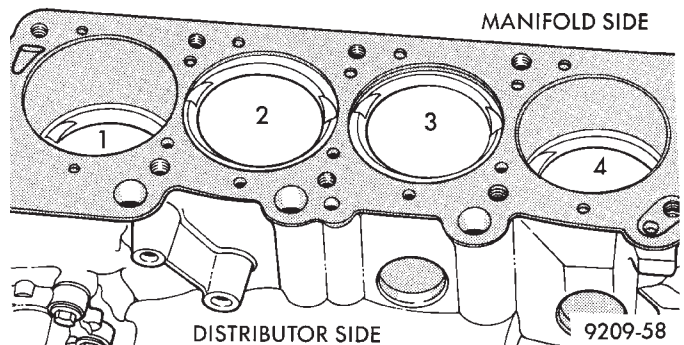

9209-58

Fig. 16 Piston Markings

- (4) The valve cut should be toward the manifold side of the engine (Fig. 16).
- (5) Install connecting rod bolt protectors on rod bolts (Fig. 4).

(6) Rotate crankshaft so that the connecting rod journal is on the center of the cylinder bore. Insert rod and piston into cylinder bore and guide rod over the crankshaft journal.

(7) Tap the piston down in cylinder bore, using a hammer handle. At the same time, guide connecting rod into position on connecting rod journal.

(8) Install rod caps. Install nuts on cleaned and oiled rod bolts and tighten nuts to 54 N•m (40 ft. lb.) Plus 1/4 turn.

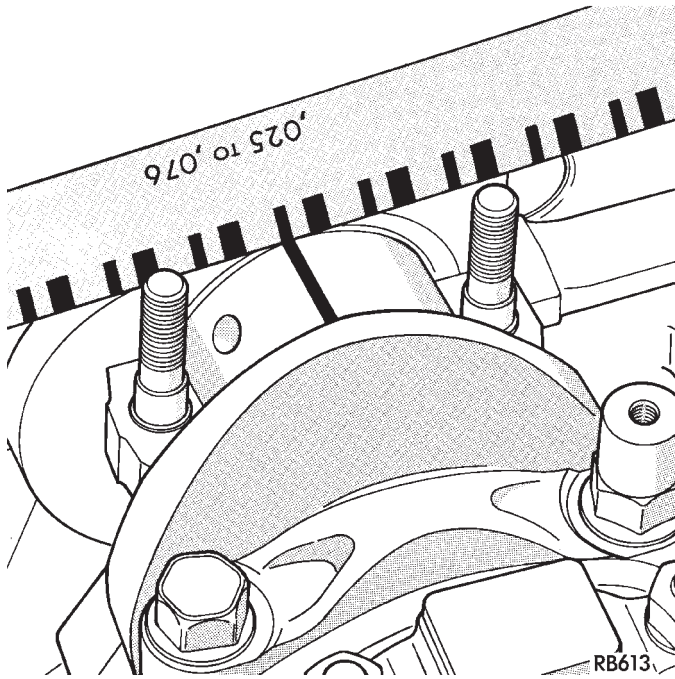

Fig. 17 Checking Connecting Rod Bearing Clearance

CONNECTING RODS

(1) Follow procedure specified in the Standard Service Procedures Section for Measuring Main Bearing Clearance and Connecting Rod Bearing Clearance (Fig. 17). Refer to specifications (Fig. 20).

CAUTION: Do not rotate crankshaft or the Plastic-Gage may be smeared.

The rod bearing bolts should be examined before reuse. If the threads are necked down the bolts should be replaced (Fig. 18).

Necking can be checked by holding a scale or straight edge against the threads. If all the threads do not contact the scale the bolt should be replaced.

(2) Before installing the nuts the threads should be oiled with engine oil.

(3) Install nuts on each bolt finger tight than alternately torque each nut to assemble the cap properly.

(4) Tighten the nuts to 54 N•m PLUS 1/4 turn (40 ft. lbs. PLUS 1/4 turn). **Do not use a torque wrench for last step.**

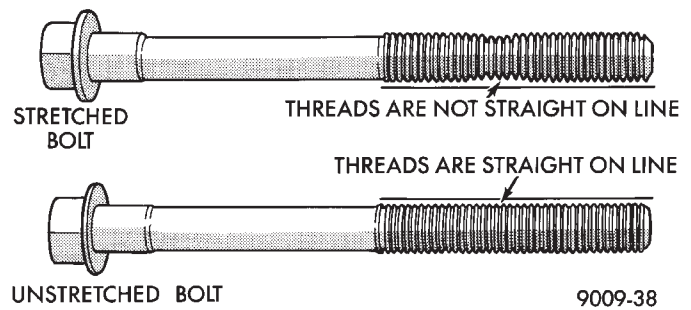

Fig. 18 Checking Bolts for Stretching (Necked)

(5) Using a feeler gauge, check connecting rod side clearance (Fig. 19). Refer to connecting rod specifications (Fig. 20).

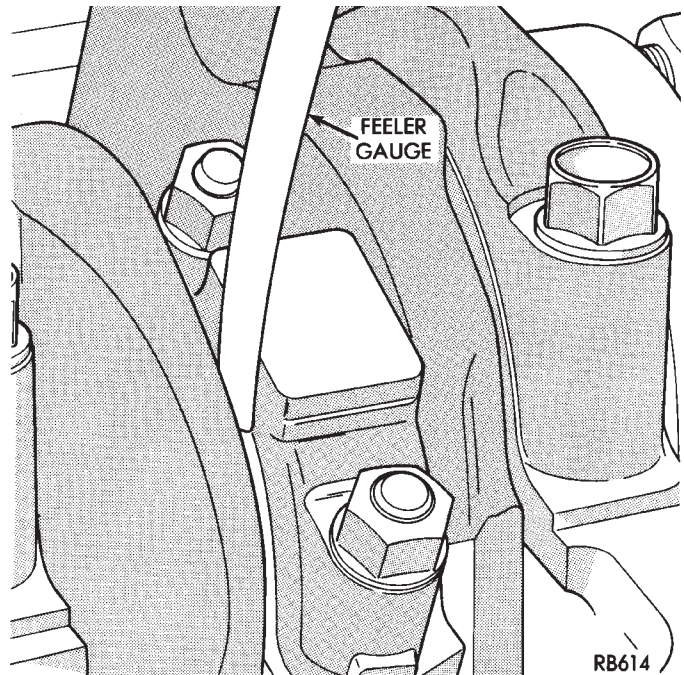

Fig. 19 Checking Connecting Rod Side Clearance

| Connecting Rod Bearing Clearance | |
|----------------------------------|---|
| New Part | .019 to .087 mm (.0008 to .0034 in.) |
| Wear Limit | .107 mm (.0042 in.) |
| Connecting Rod Side Clearance | |
| New Part | 0.13 to 0.32 mm (.005 to .013 in.) |
| Wear Limit | 0.37 (.015 in.) |

9109-15

Fig 20 Connecting Rod Specifications

ENGINE CORE PLUGS

REMOVAL

Using a blunt tool such as a drift or a screwdriver and a hammer, strike the bottom edge of the cup

plug (Fig. 21). With the cup plug rotated, grasp firmly with pliers or other suitable tool and remove plug (Fig. 21).

CAUTION: Do not drive cup plug into the casting as restricted cooling can result and cause serious engine problems.

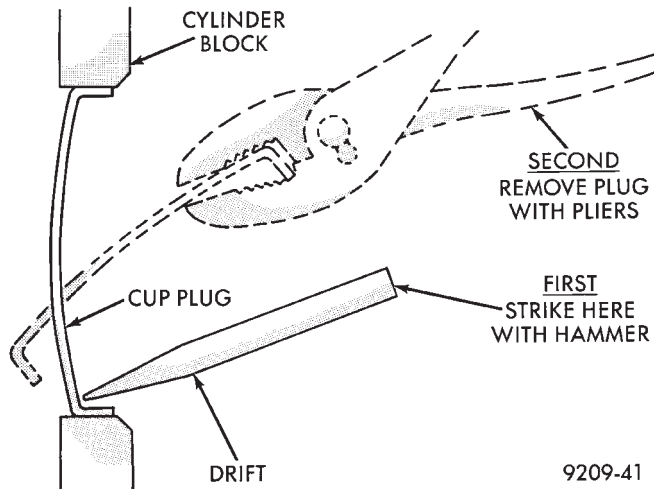

Fig. 21 Core Hole Plug Removal

INSTALLATION

Thoroughly clean inside of cup plug hole in cylinder block or head. Be sure to remove old sealer. Lightly coat inside of cup plug hole with sealer. Make certain the new plug is cleaned of all oil or grease. Using proper drive plug, drive plug into hole so that the sharp edge of the plug is at least 0.5mm (.020 inch) inside the lead-in chamfer (Fig. 21).

It is not necessary to wait for curing of the sealant. The cooling system can be refilled and the vehicle placed in service immediately.



CRANKSHAFT, INTERMEDIATE AND BALANCE SHAFT ASSEMBLIES SERVICE

| FASTENER TORQUE | | | |
|-----------------|----------------------|----------|----------|
| LETTER | N·m | IN. LBS. | FT. LBS. |
| ◇ | 12 | 105 | — |
| ◇ | 28 | 250 | — |
| ◇ | 54 | — | 40 |
| ★◇ | ★41 | — | ★30 |
| ◇ | 95 | — | 70 |
| ◇ | (PLUG - LOCTITE 277) | | |
| ◇ | 15 | 130 | — |

★SPECIFIED TORQUE PLUS 1/4 TURN

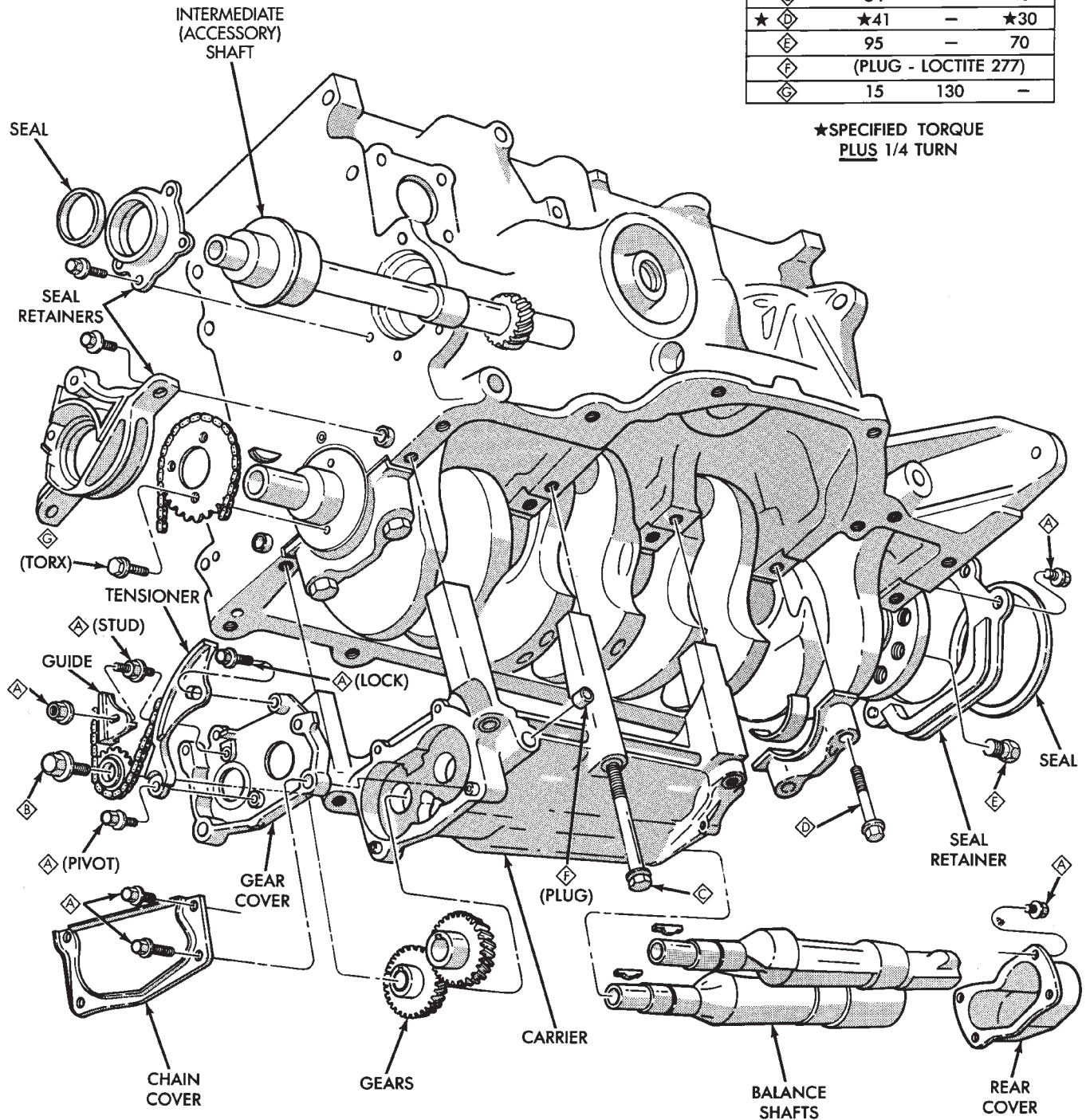

9209-18

Fig. 1 Crankshaft Intermediate and Balance Shaft Assemblies and Oil Seals

CRANKSHAFT OIL SEALS SERVICE

(1) Pry out rear seal with screwdriver. Be careful not to nick or damage crankshaft flange seal surface or retainer bore (Fig. 2).

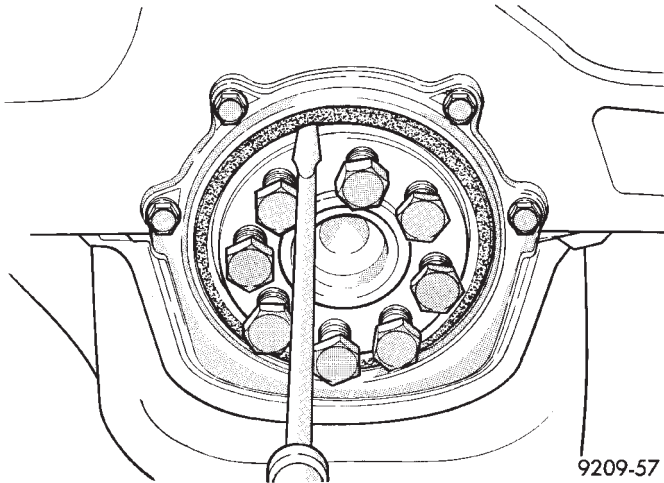

Fig. 2 Removing Rear Crankshaft Oil Seal

- (2) Place Special Tool C-4681 on crankshaft (Fig. 3).
- (3) Lightly coat seal O.D. with Loctite Stud N' Bearing Mount or equivalent.
- (4) Place seal over Tool C-4681 and tap in place with a plastic hammer.

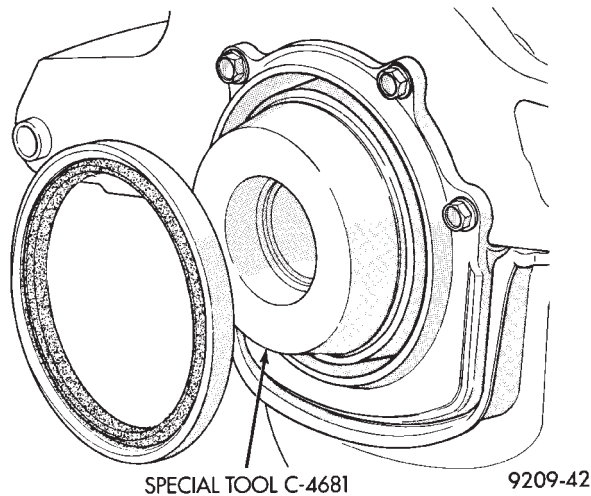

Fig. 3 Installing Rear Crankshaft Oil Seal

REAR CRANKSHAFT SEAL RETAINER AND OIL SEAL

When retainer removal is required, use Mopar Gasket Maker applied as shown in (Fig 4.) to provide retainer to block sealing during re-installation.

FRONT CRANKSHAFT SEAL RETAINER

See Timing System and Seals Section for timing belt covers, belt, crankshaft sprocket and oil seals removal and installation.

- (1) Remove retainer screws (Fig. 5).

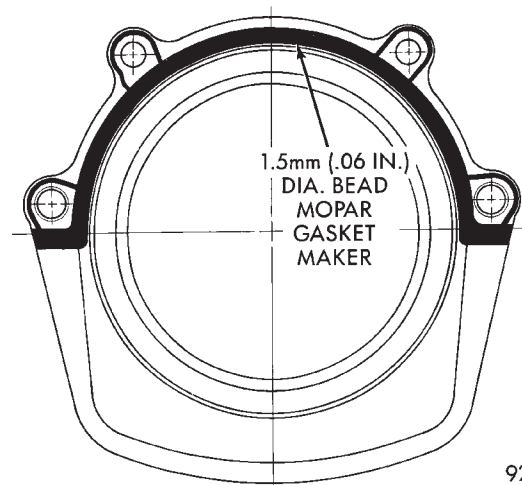

Fig. 4 Rear Crankshaft Seal Retainer Sealing

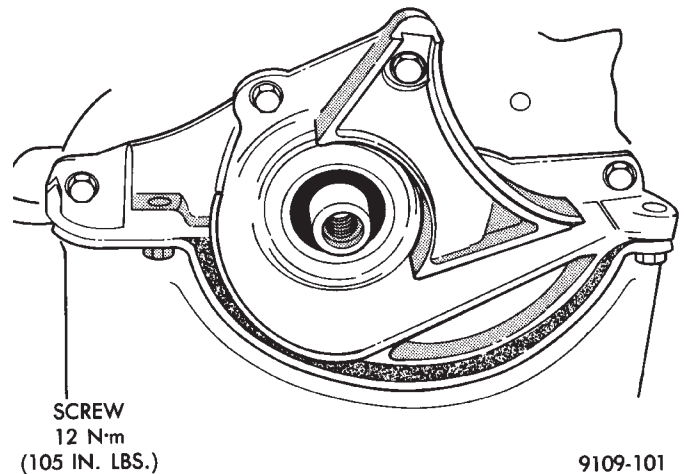

Fig. 5 Front Crankshaft Oil Seal Retainer

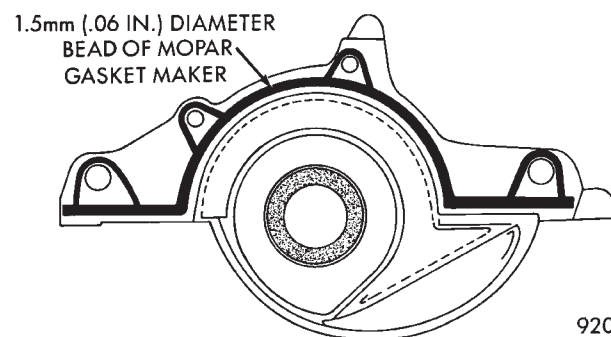

Fig. 6 Front Crankshaft Seal Retainer Sealing

For reassembly Mopar Gasket Maker is applied to the retainer as shown in (Fig. 6). This material cures in the absence of air providing retainer to block sealing.

- (2) Install retainer and tighten screws to 12 N•m (105 in. lbs.).

CRANKSHAFT SERVICE

CRANKSHAFT MAIN BEARINGS

Bearing caps are not interchangeable and should be marked at removal to insure correct assembly. Upper and lower bearing halves are NOT interchangeable. Lower main bearing halves of 1, 2, 4 and 5 are interchangeable. Upper main bearing halves of 1, 2, 4 and 5 are interchangeable.

CRANKSHAFT MAIN JOURNALS

The crankshaft journals should be checked for excessive wear, taper and scoring. (Fig. 7) Limits of taper or out-of-round on any crankshaft journals should be held to .025mm (.001 inch). Journal grinding should not exceed .305mm (.012 inch) under the standard journal diameter. Do NOT grind thrust faces of Number 3 main bearing. Do NOT nick crank pin or bearing fillets. After grinding, remove rough edges from crankshaft oil holes and clean out all passages.

CAUTION: With the nodular cast iron crankshafts used it is important that the final paper or cloth polish after any journal regrind be in the same direction as normal rotation in the engine.

Upper and lower Number 3 bearing halves are flanged to carry the crankshaft thrust loads and are NOT interchangeable with any other bearing halves in the engine (Fig. 7). All bearing cap bolts removed during service procedures are to be cleaned and oiled before installation. Bearing shells are available in standard and the following undersized: 0.025mm (.001 inch), .051mm (.002 inch), .076mm (.003 inch), .254mm (.010 inch), and .305mm (.012 inch). Never install an undersize bearing that will reduce clearance below specifications.

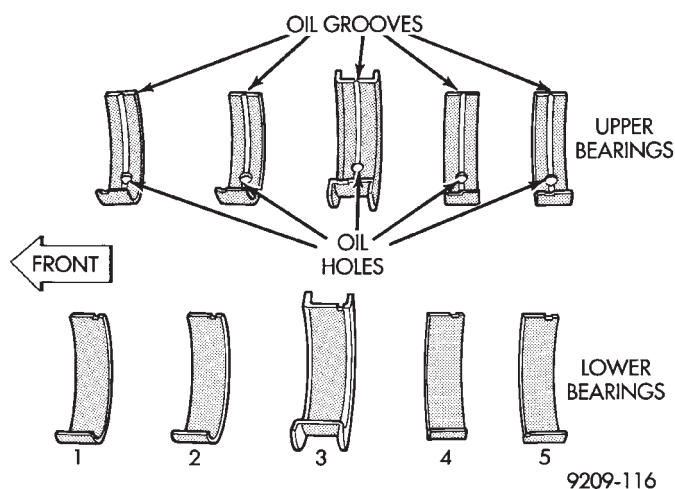

Fig. 7 Main Bearing Identification

MAIN BEARING SERVICE—CRANKSHAFT NOT REMOVED

REMOVAL

- (1) Remove oil pan and identify bearing caps before removal.
- (2) Remove bearing caps one at a time. Remove upper half of bearing by inserting Special Main Bearing Tool C-3059 (Fig. 8) into the oil hole of crankshaft.
- (3) Slowly rotate crankshaft clockwise, forcing out upper half of bearing shell.

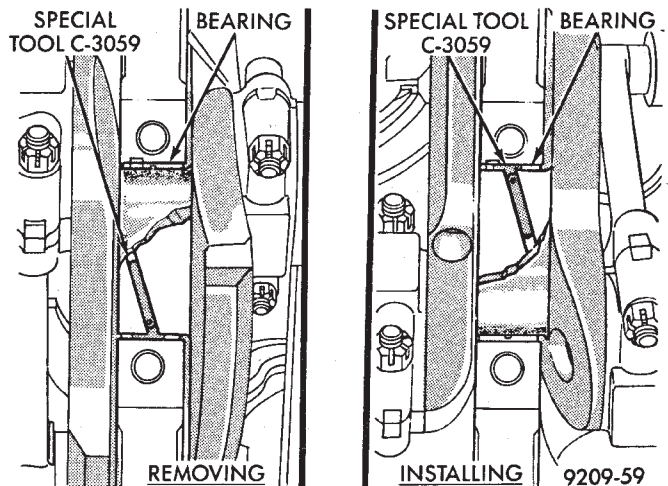

Fig. 8 Removing and Installing Upper Main Bearing With Special Tool C-3059

INSTALLATION

Only one main bearing should be selectively fitted while all other main bearing caps are properly tightened.

When installing a new upper bearing shell, slightly chamfer the sharp edges from the plain side.

- (1) Start bearing in place, and insert Main Bearing Tool C-3059 into oil hole of crankshaft (Fig. 8).
- (2) Slowly rotate crankshaft counter-clockwise sliding the bearing into position. Remove Special Main Bearing Tool C-3059.

CHECKING CRANKSHAFT END PLAY

- (1) Mount a dial indicator to front of engine, locating probe on nose of crankshaft (Fig. 9).
- (2) Move crankshaft all the way to the rear of its travel.
- (3) Zero the dial indicator.
- (4) Move crankshaft all the way to the front and read the dial indicator. Refer to (Fig. 10) for specifications.

OPTIONAL CRANKSHAFT END PLAY CHECK

- (1) Move crankshaft all the way to the rear of its travel using the appropriate tool inserted between a

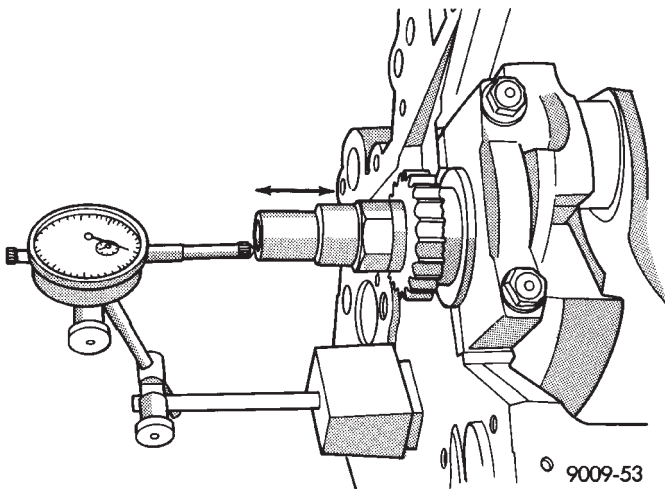

Fig. 9 Checking Crankshaft End Play

main bearing cap and a crankshaft cheek, using care not to damage any bearing surface. Do **not** loosen main bearing cap.

(2) Use a feeler gauge between number three thrust bearing and machined crankshaft surface to determine end play.

| | |
|--|---|
| Crankshaft End-Play | |
| New Part: .05 to 0.018 mm (.002 to .007 in.) | |
| Wear Limit: 0.37 mm (.015 in.) | |
| Main and Connecting Rod Bearing Clearance | |
| New Part: .011 to .072 mm (.0004 to .0028 in.) | |
| Wear Limit: .102 mm (.004 in.) | |
| Crankshaft Journal Sizes | |
| Crankshaft Main Bearing Journal | |
| ALL | Diameter |
| Standard | 60.000 ± 0.013 mm (2.3622 ± .0005 in.) |
| 1st Undersize | 59.75 ± 0.013 mm (2.3523 ± .0005 in.) |
| Crankshaft Connecting Rod Journal | |
| ALL | Diameter |
| Standard | 50.00 ± 0.013 (1.9685 ± .0005 in.) |
| 1st Undersize | 49.75 ± 0.013 in. (1.9586 ± .0005 in.) |

9109-10

Fig. 10 Crankshaft Specifications

CRANKSHAFT BEARING CLEARANCE

(1) Refer to Measuring Main, Connecting Rod Bearing Clearance in Standard Service Procedures. Refer to (Fig. 10) for specifications.

CAUTION: Do not rotate crankshaft or the Plastigage maybe smeared.

(2) Install the main bearing shells with the lubrication groove in the cylinder block (Fig. 12). **The 1, 2, 4 and 5 main bearings are full groove to provide full time oiling to the connecting rod. Only the number 3 is half-groove.**

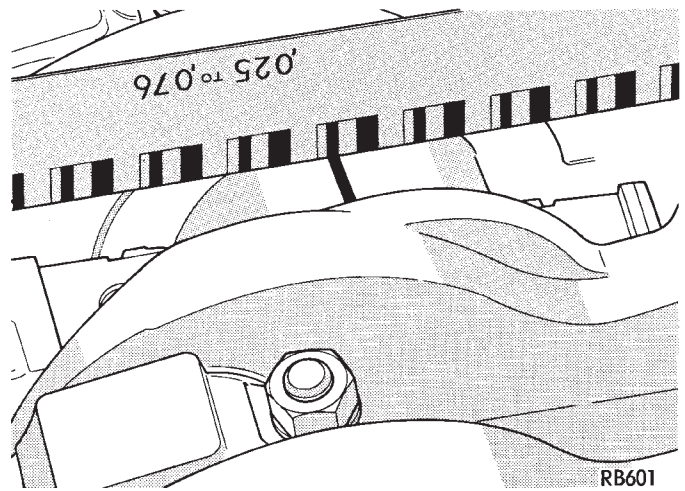

Fig. 11 Checking Crankshaft Oil Clearance with Plastigage

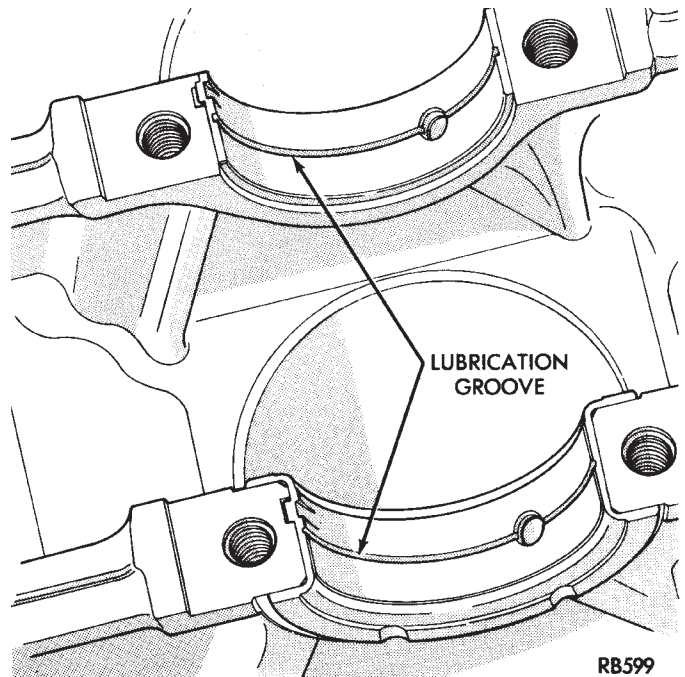

Fig. 12 Installing Main Bearing Upper Shell

(3) Make certain oil holes in block line up with oil hole in bearings and bearing tabs seat in the block tab slots.

(4) Oil the bearings and journals and install crankshaft.

(5) Install main bearing cap No.1 on timing belt end.

(6) Install main bearing cap No.5 on transmission end.

Since the main bearing bolts are torqued using a new procedure they should be examined BEFORE reuse. If the threads are necked down the bolts should be replaced (Fig. 15).

Necking can be checked by holding a scale or straight edge against the threads or by running a M11 x 1.50 nut the full length of the thread. If all

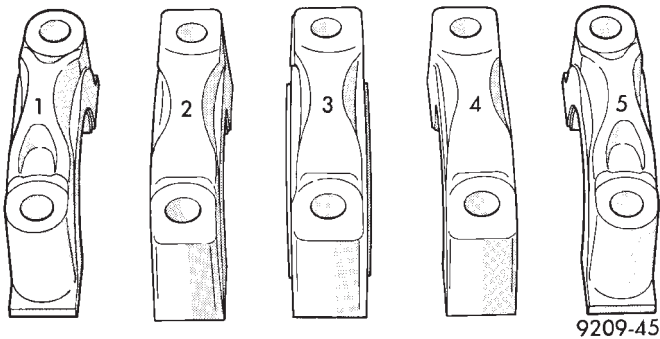

Fig. 13 Main Bearing Caps

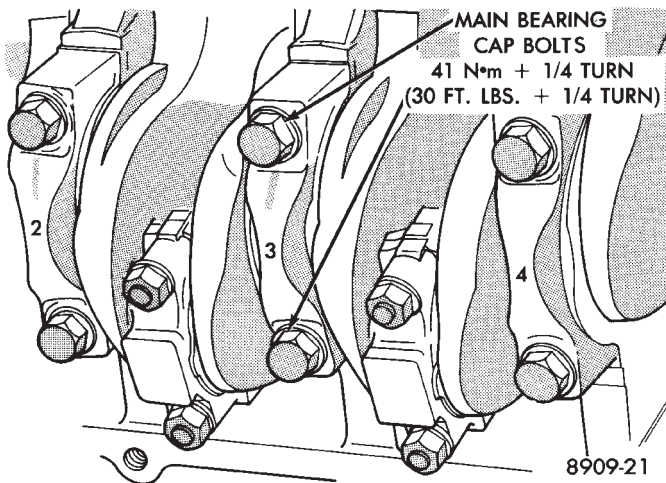

Fig. 14 Installing Main Bearing Caps

the threads do not contact the scale or if the nut does not run down smoothly the bolt should be replaced.

(7) Before installing the bolts the threads should be oiled with engine oil.

(8) Install both bolts in each cap finger tight, then alternately torque each bolt to assemble the cap properly.

(9) Tighten the bolts to 41 N•m plus 1/4 turn (30 ft. lbs. plus 1/4 turn). (Fig. 14)

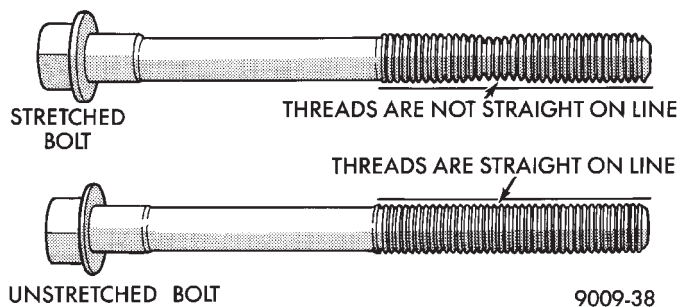

Fig. 15 Checking Bolts For Stretching (Necked down)

BALANCE SHAFTS

2.5L engines are equipped with two balance shafts installed in a carrier attached to the lower crankcase (Fig. 1).

The shafts are interconnected through gears to rotate in opposite directions. These gears are driven by a short chain from the crankshaft, to rotate at two times crankshaft speed. This counterbalances certain engine reciprocating masses.

REMOVAL

Refer to Engine Lubrication, Timing System and Seals Service of this group for removal procedure of necessary components to repair balance shafts.

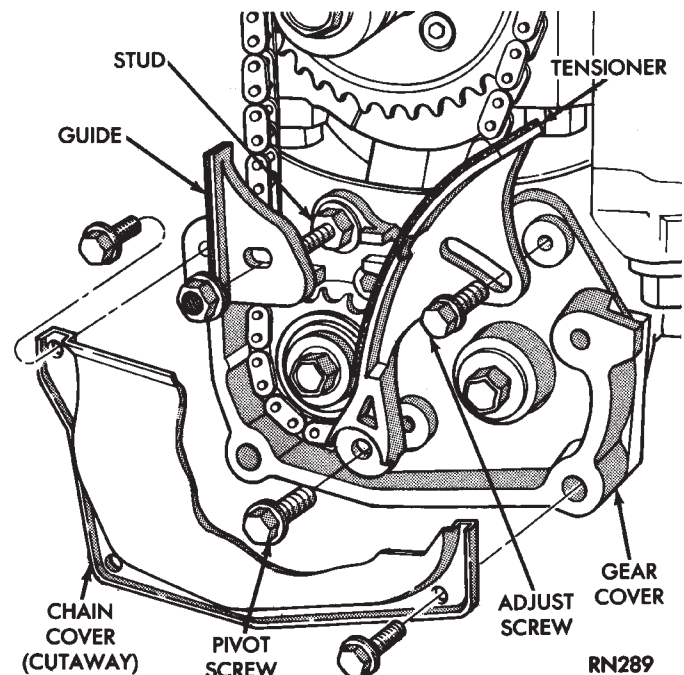

Fig. 16 Chain Cover, Guide and Tensioner

(1) Remove chain cover, guide and tensioner (Fig. 16). Also see Carrier Assembly Removal for service procedures requiring only temporary relocation of assembly.

(2) Remove balance shaft gear and chain sprocket retaining screws and crankshaft chain sprocket torx screws. Remove chain and sprocket assembly. (Fig. 17)

(3) Remove gear cover retaining stud (double ended to also retain chain guide). Remove cover and balance shaft gears (Fig. 18).

(4) Remove carrier rear cover and balance shafts. (Fig. 18).

(5) Remove six carrier to crankcase attaching bolts to separate carrier (Fig. 1).

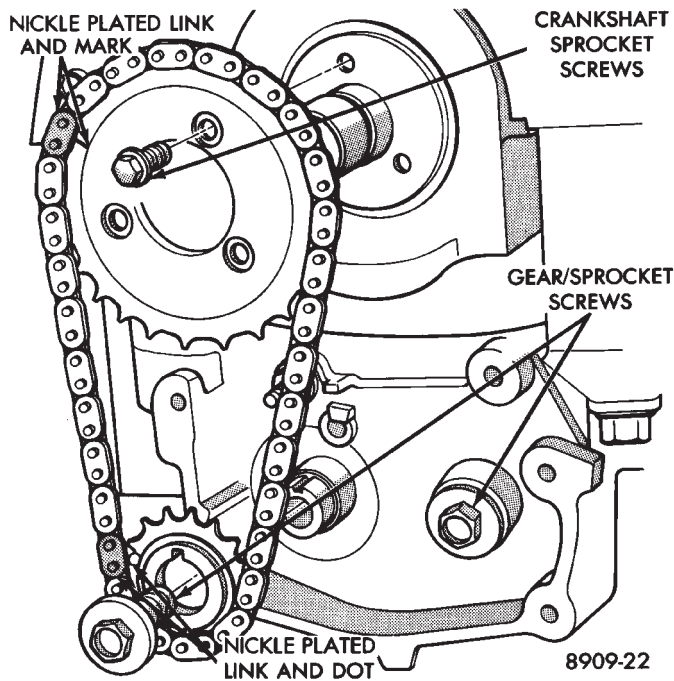

Fig. 17 Drive Chain and Sprockets

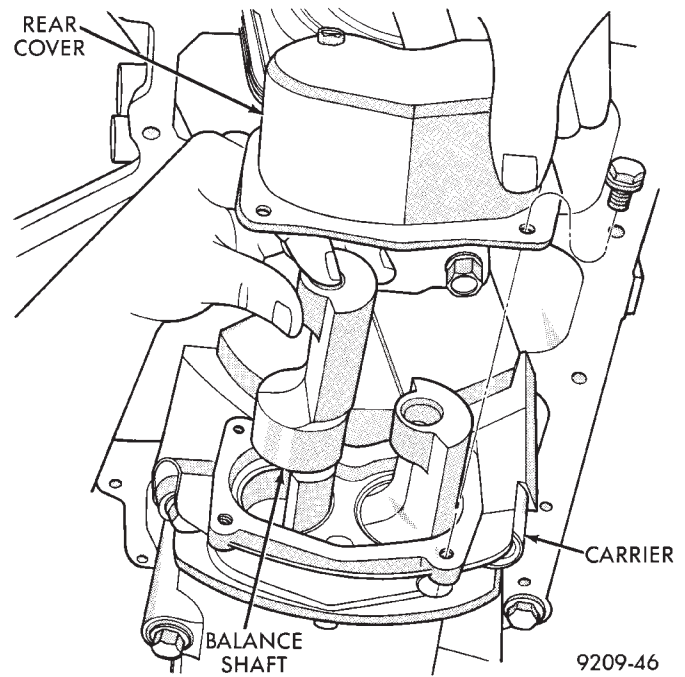

Fig. 19 Balance Shaft(s) Remove/Install

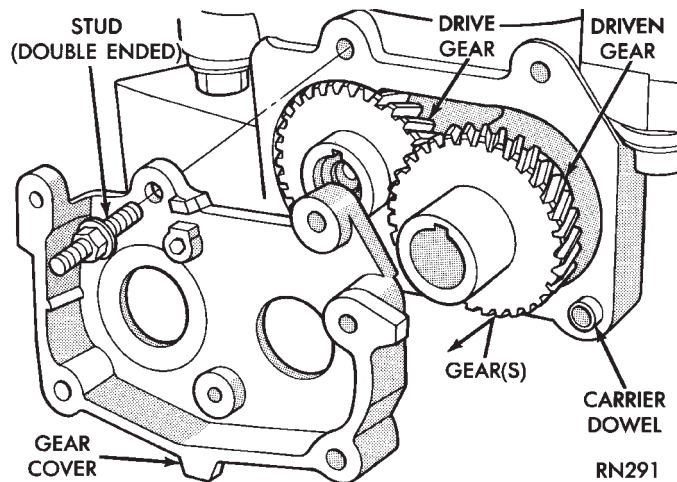

Fig. 18 Gear Cover and Gears

BALANCE SHAFTS CARRIER ASSEMBLY

REMOVAL

The following components will remain intact during carrier removal. Gear cover, gears, balance shafts and the rear cover.

- (1) Remove chain cover and driven balance shaft chain sprocket screw.
- (2) Loosen tensioner pivot and adjusting screws, move driven balance shaft inboard through driven chain sprocket. Sprocket will hang in lower chain loop.
- (3) Remove carrier to crankcase attaching bolts to remove carrier.

INSTALLATION

Balance shaft and carrier assembly installation is the reverse of the removal procedure. **During installation crankshaft to balance shaft timing must be established.**

TIMING

- (1) With balance shafts installed in carrier (Fig. 18) position carrier on crankcase and install six attaching bolts and tighten to 54 N•m (40 ft. lbs.).
- (2) Turn balance shafts until both shaft key ways are up Parallel to vertical centerline of engine. Install short hub drive gear on sprocket driven shaft and long hub gear on gear driven shaft. After installation gear and balance shaft keyways must be up with gear timing marks meshed as shown in (Fig. 20).
- (3) Install gear cover and tighten double ended stud/washer fastener to 12 N•m (105 in. lbs.).
- (4) Install crankshaft sprocket and tighten socket head torx screws to 13 N•m (130 in. lbs.).

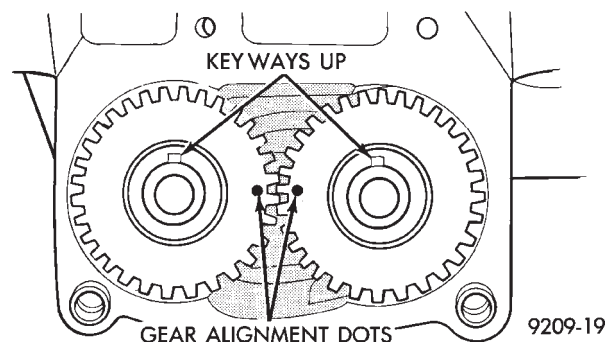

Fig. 20 Gear Timing

(5) Turn crankshaft until number one cylinder is at Top Dead Center (TDC). The timing marks on the chain sprocket should line up with the parting line on the left side of number one main bearing cap. (Fig. 21).

(6) Place chain over crankshaft sprocket so that the nickel plated link of the chain is over the timing mark on the crankshaft sprocket (Fig. 21).

(7) Place balance shaft sprocket into the timing chain (Fig. 17) so that the timing mark on the sprocket (yellow dot) mates with the (lower) nickel plated link on the chain

(8) With balance shaft keyways pointing up 12 o'clock slide the balance shaft sprocket onto the nose of the balance shaft. The balance shaft may have to be pushed in slightly to allow for clearance.

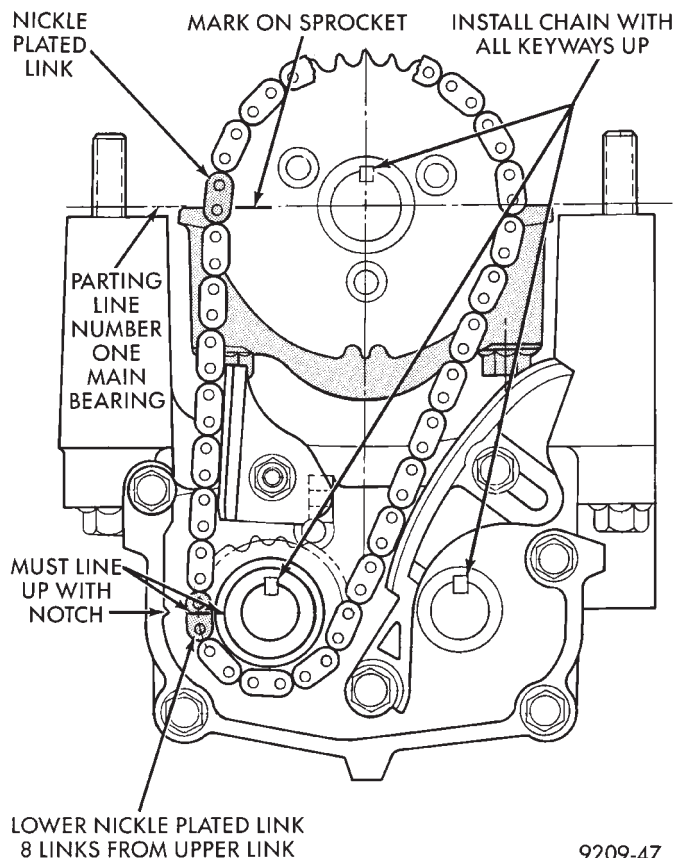

Fig. 21 Balance Shaft Timing

THE TIMING MARK ON THE SPROCKET, THE (LOWER) NICKEL PLATED LINK, AND THE ARROW ON THE SIDE OF THE GEAR COVER SHOULD LINE UP WHEN THE BALANCE SHAFTS ARE TIMED CORRECTLY.

(9) If the sprockets are timed correctly install the balance shaft bolts and tighten to 28 N•m (250 in. lbs.). A wood block placed between crankcase and crankshaft counterbalance will prevent crankshaft and gear rotation.

CHAIN TENSIONING

(1) Install chain tensioner loosely assembled.

(2) Position guide on double ended stud making sure tab on the guide fits into slot on the gear cover. Install and tighten nut/washer assembly to 12 N•m (105 in. lbs.).

(3) Place a shim 1mm (.039 inch) thick x 70mm (2.75 inch) long or between tensioner and chain. Push tensioner and shim up against the chain. **Apply firm pressure (5.5 to 6.6 lbs.) directly behind the adjustment slot to take up all slack** (chain must have shoe radius contact as shown in Fig. 22).

(4) With the load applied, tighten top tensioner bolt first, then bottom pivot bolt. Tighten bolts to 12 N•m (105 in. lbs.), Remove shim.

(5) Install carrier covers and tighten screws to 12 N•m (105 in. lbs.).

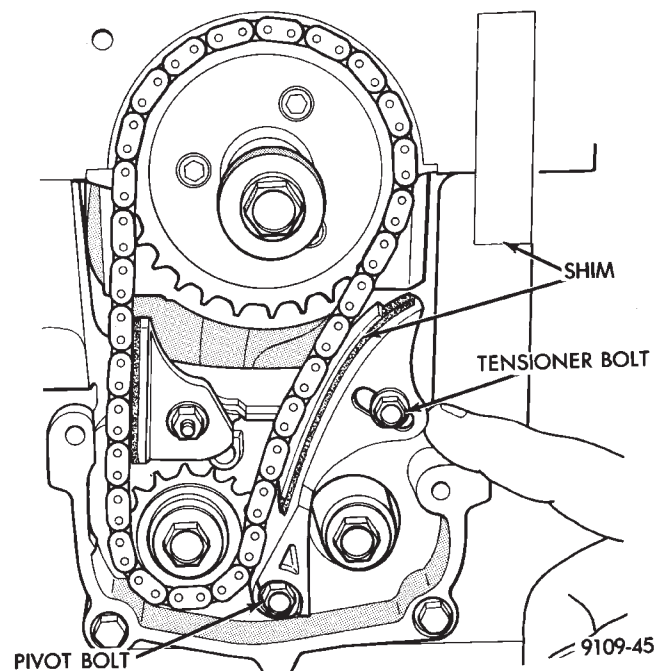

Fig. 22 Chain Tension Adjustment

INTERMEDIATE SHAFT SERVICE

REMOVAL

CAUTION: The oil pump and distributor must be removed before attempting to remove intermediate shaft.

(1) Hold sprocket with Tool C-4687 and adaptor Tool C-4687-1 when removing or installing screw (Fig. 23).

(2) See Timing System and Seals for intermediate seal removal and replacement.

(3) Remove retainer screws (Fig. 24).

(4) Remove retainer and lay aside.

(5) Remove intermediate shaft.

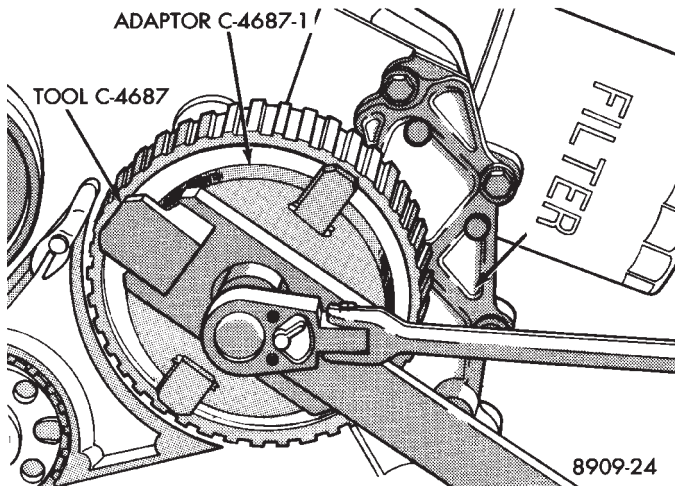

Fig. 23 Removing/Installing Intermediate Shaft Sprocket

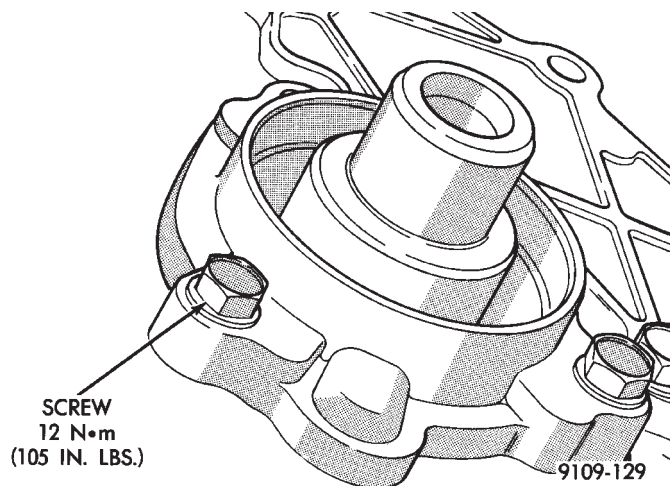

Fig. 24 Intermediate Shaft Retainer

1.5 MM (.06 IN.) DIAMETER BEAD GASKET MAKER

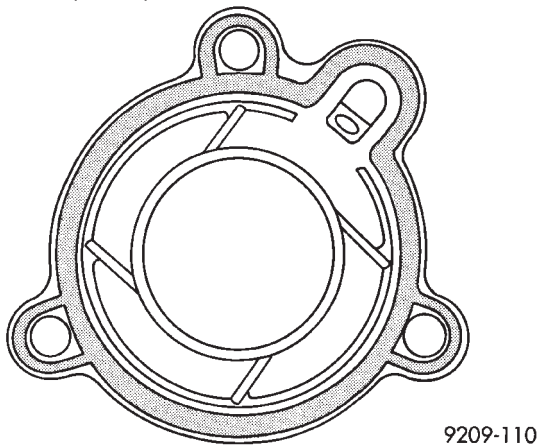

Fig. 25 Intermediate Shaft Retainer Sealing

INSTALLATION

- (1) Lubricate distributor drive gear when installing.
- (2) Apply Mopar Gasket Maker as shown in (Fig. 25) and install intermediate shaft retainer.

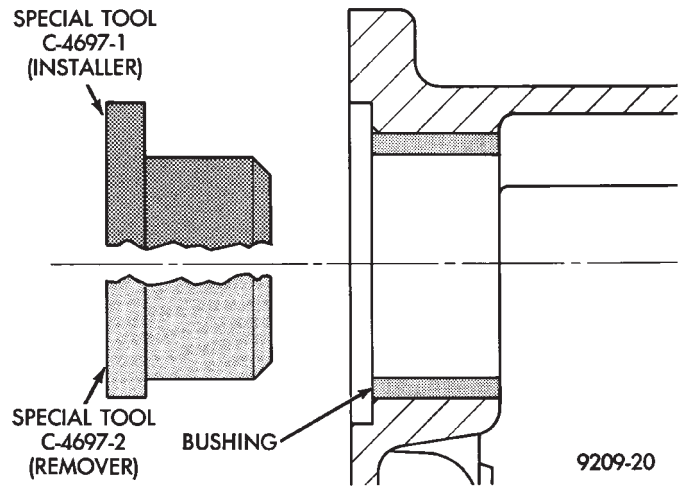

Fig. 26 Intermediate Shaft Bushing, Front

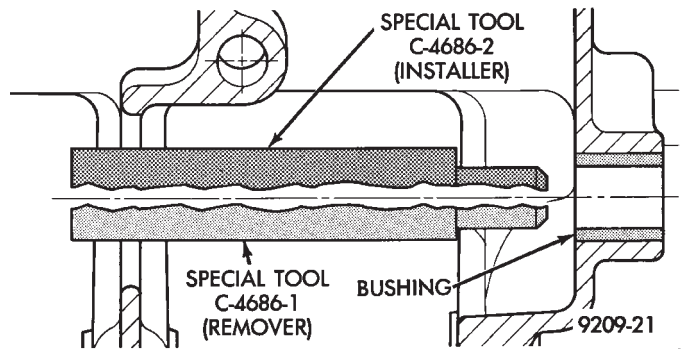

Fig. 27 Intermediate Shaft Bushing—Rear

| Intermediate Shaft Journal and Bushing Sizes | |
|---|------------------------------------|
| Intermediate Shaft | |
| Large Journal | 42.670/42.695 mm (1.679/1.680 in.) |
| Small Journal | 19.670/19.695 mm (.774/.775 in.) |
| Bushing-Bore Diameter | |
| Large Bushing | 42.730/42.750 mm (1.682/1.683 in.) |
| Small Bushing | 19.720/19.750 mm (.776/.777 in.) |
| Maximum Clearance Allowed | |
| Large | .035/.080 mm (.0013/.003 in.) |
| Small | .025/.080 mm (.0009/.003 in.) |

9109-11

Fig. 28 Intermediate Shaft Journal Specifications

- (3) Install retaining screws and torque to 12 N•m (105 in. lbs.).

INTERMEDIATE SHAFT BUSHING SERVICE

- (1) Remove front bushing using Special Tool C-4697-2 with Special Tool Handle C-4171 (Fig. 26).
- (2) Install front bushing using Special Tool C-4697-1 and Special Tool Handle C-4171 until tool is flush with block.
- (3) Remove rear bushing using Special Tool C-4686-2 and Special Tool Handle C-4171 (Fig. 27).
- (4) Install rear bushing using Special Tool C-4686-1 and Special Tool Handle C-4171 until tool is flush with block.



ENGINE LUBRICATION SYSTEM

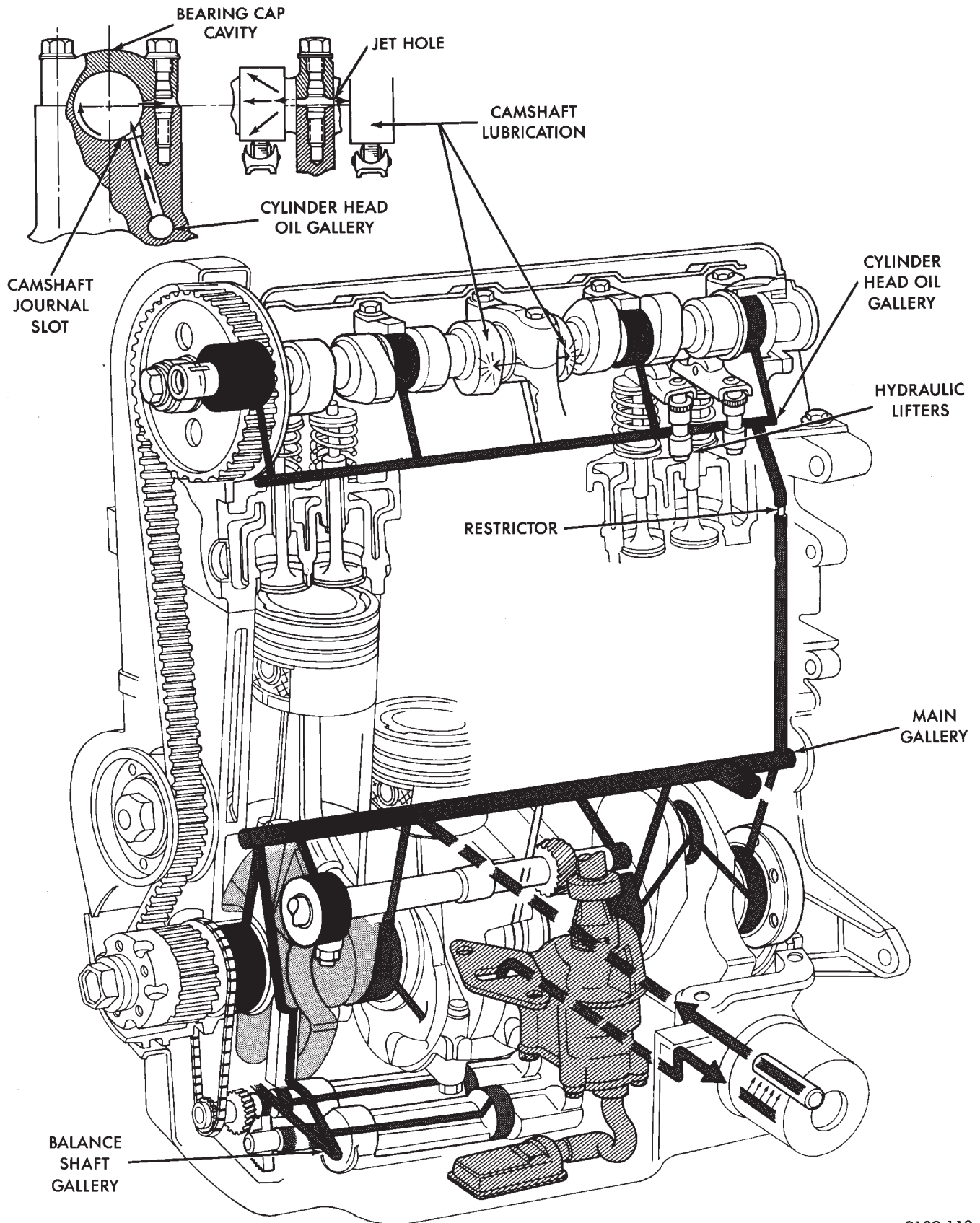

9109-110

Fig. 1 Engine Lubrication System

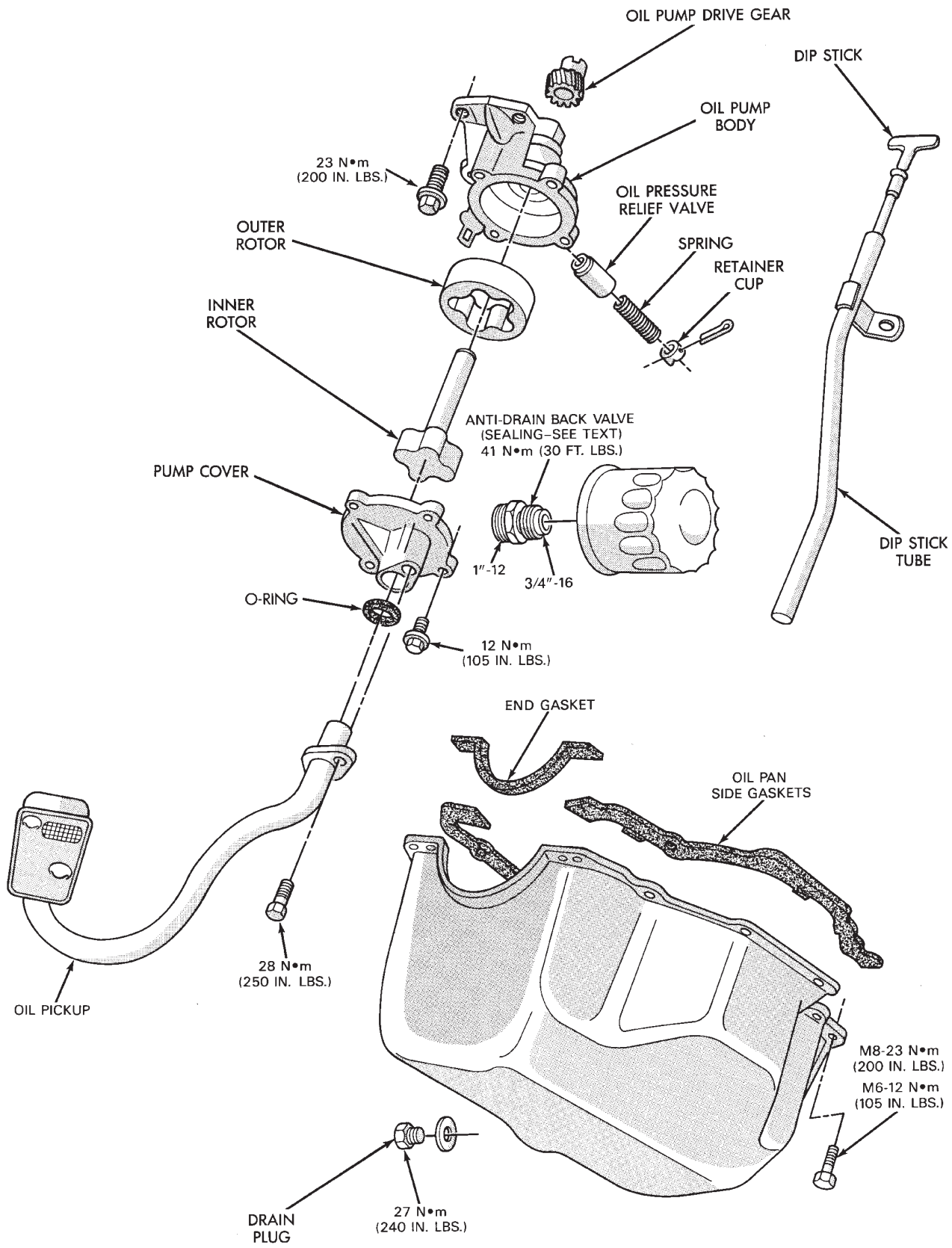

9209-17

Fig. 2 Engine Lubrication Components

OIL PAN

A formed steel oil pan provides lower engine protection as well as serving as the engine oil reservoir (Fig. 2). Pan side flanges to block are sealed with gaskets. The 2.5L engine pickup is unsupported and the lower end has a box type strainer (Fig. 4).

PRESSURE LUBRICATION

Oil drawn up through the pickup tube is pressurized by the pump and routed through the full flow filter to the main oil gallery running the length of the cylinder block (Fig. 1). Modified oil pickup, pump and check valve provide increased oil flow to the main oil gallery.

MAIN/ROD BEARINGS

A diagonal hole in each bulkhead feeds oil to each main bearing. Drilled passages within the crankshaft route oil from main bearing journals to crankpin journals (Fig. 1).

ACCESSORY SHAFT

Two separate holes supply oil to the accessory shaft.

BALANCE SHAFTS

For 2.5L engine balance shafts lubrication an additional hole interconnects with a passage in one leg of the balance shaft carrier to route oil down to the carrier oil gallery. This gallery directly supplies the balance shafts front bearings and internal machined passages in the shafts routes oil from front to rear shaft bearing journals.

CAMSHAFT/HYDRAULIC LIFTERS

A vertical hole at the number five bulkhead routes (through a restrictor) pressurized oil up past a cylinder head bolt to an oil gallery running the length of the cylinder head. Hydraulic adjusters are supplied directly from this gallery while diagonal holes supply oil to the camshaft journals. The camshaft journals are partially slotted to allow a predetermined amount of pressurized oil to pass into the bearing cap cavities with small holes directed to spray lubricate the camshaft lobes.

SPLASH LUBRICATION

Oil returning to the pan from pressurized components supplies lubrication to the valve stems. Cylinder bores and wrist pins are splash lubricated from directed holes in the connecting rods.

OIL PAN

REMOVAL

- (1) Drain engine oil and remove oil pan.
- (2) Clean oil pan and all gasket surfaces.

OIL PAN RAIL TO BLOCK SEALING

2.5L engines use side gaskets for rail sealing (Fig. 2).

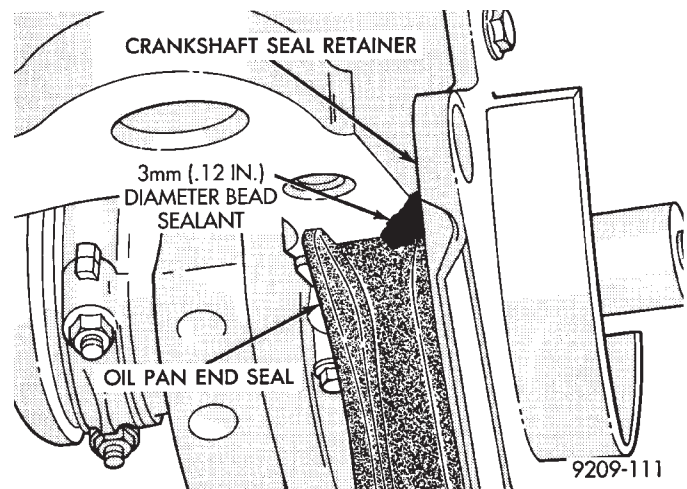

Fig. 3 Sealing, Front and Rear End Seals

INSTALLATION

- (1) Apply Mopar Silicone Rubber Adhesive Sealant or equivalent at the front seal retainer parting line (Fig. 3).
- (2) Install the oil pan side gaskets to the block. Use heavy grease or Mopar Silicone Rubber Adhesive Sealant or equivalent to hold in place.
- (3) Apply Mopar Silicone Rubber Adhesive Sealant or equivalent to ends of new oil pan end seals at junction of cylinder block pan rail gasket (Fig. 3).
- (4) Install pan and tighten screws to 23 N•m (200 in. lbs.).

OIL PUMP SERVICE

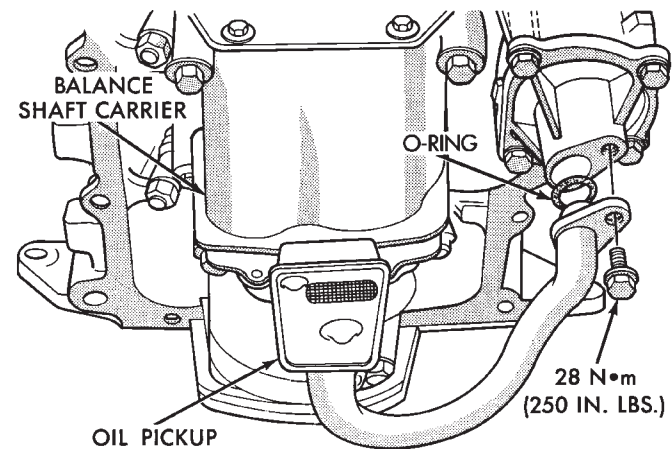

Fig. 4 Oil Pick-Up

OIL PICKUP

- (1) Remove screw on pump cover holding oil pick-up tube to oil pump (Fig. 4).
- (2) Remove oil pick-up tube. **When reinstalling make sure to use a new O-Ring on pickup tube.**

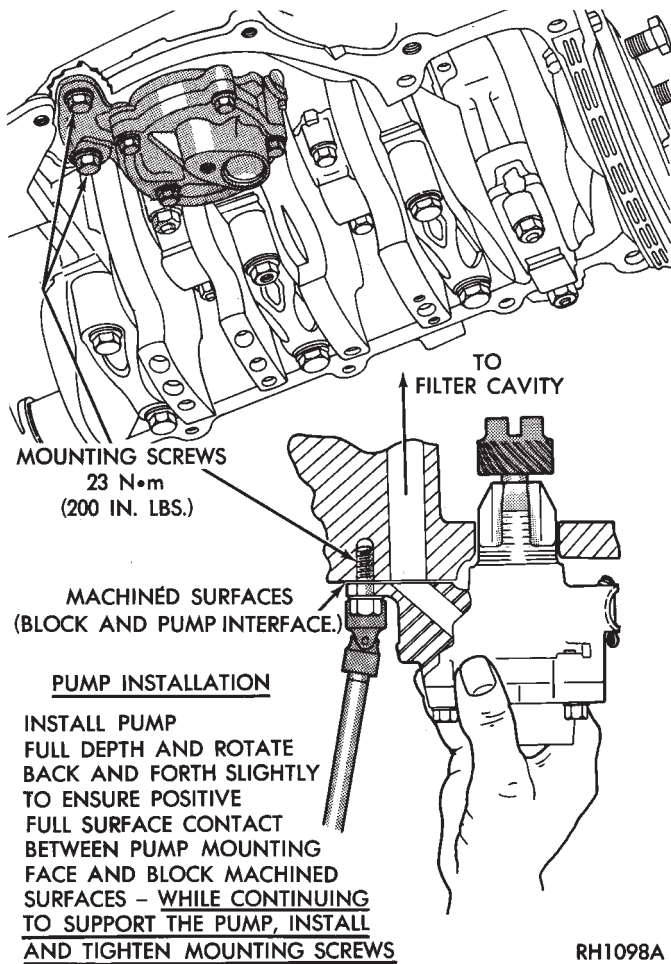

Fig. 5 Oil Pump Assembly

REMOVAL

(1) Remove two (2) screws holding oil pump to cylinder block assembly (Fig. 5).

INSTALLATION

(1) Apply Mopar Gasket Maker to pump body-to-block interface (machined surface).

(2) Lubricate oil pump rotor & shaft and drive gear.

(3) Turn crankshaft and intermediate shaft until markings on sprockets are in line (arrows Fig. 6).

(4) Slot in oil pump shaft **must** be parallel to center line of crankshaft when intermediate shaft and crankshaft are properly timed (Fig. 7).

(5) Install pump full depth and rotate back and forth slightly to ensure proper positioning and alignment through full surface contact of pump and block machined interface surfaces (Fig. 5).

CAUTION: Pump must be held in fully seated position (described above) while installing screws.

(6) Tighten screws to 23 N•m (200 in. lbs.).

INSPECTION

(1) Check rotor end clearance with feeler gauge as shown in (Fig. 8).

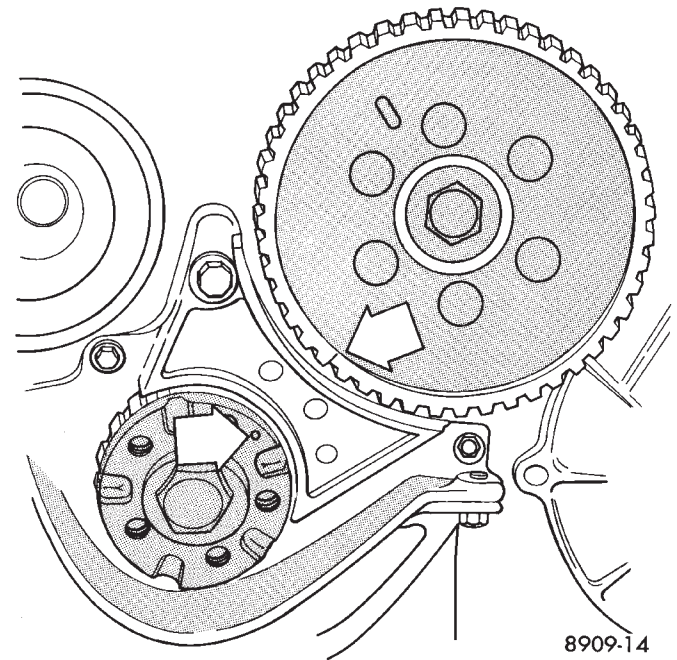

Fig. 6 Crankshaft and Intermediate Shaft Timing

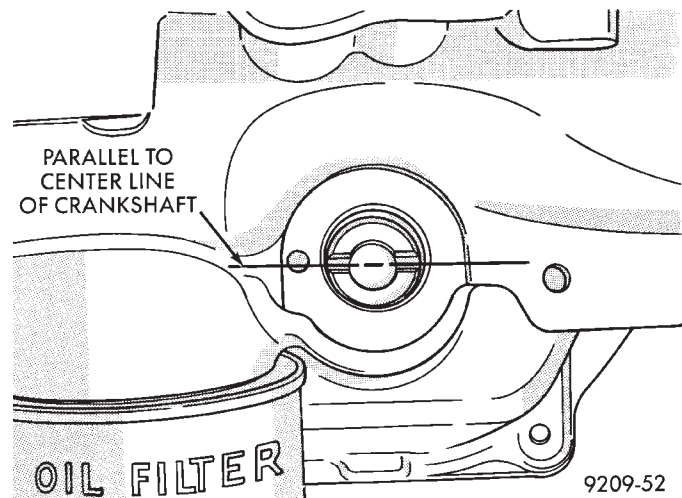
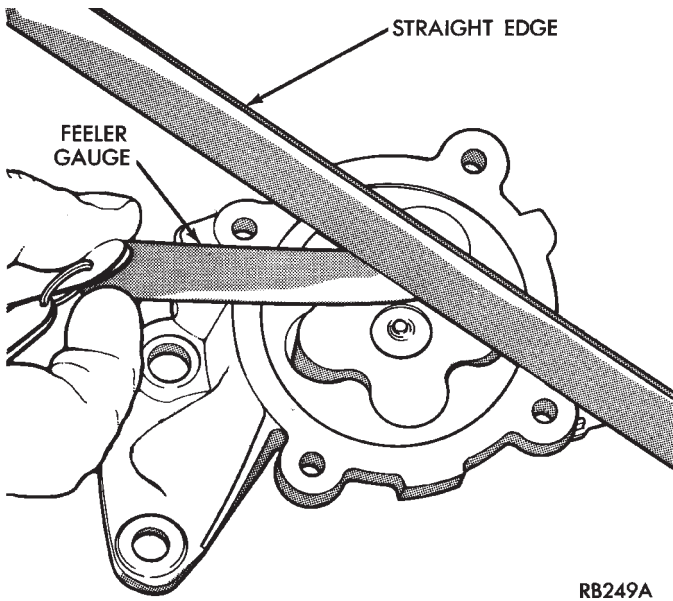

Fig. 7 Oil Pump Shaft Alignment

(2) Limits:

- 0.03mm (.001 inch) min
 - 0.09mm (.0035 inch) max.
- (3) Thickness: 23.96mm (.9435 inch) min. Outer Diameter: 62.7mm (2.469 inch) min (Fig. 9).
- (4) Install with large chamfered edge in pump body (Fig. 9).
- Clearance: 0.20mm (.008 inch) max. (Fig. 10)
 Clearance: 0.35mm (.014 inch) max. (Fig. 11)
 Clearance: 0.076mm (.003 inch) max. (Fig. 12)
 Oil pressure relief valve spring: Free length: 49.5mm (1.95 inch). Load: 89 N at 34mm. Load: (20 lbs. at 1.34 inch) (Fig. 13).
 Thickness: 23.96mm (.9435 inch) Minimum (Fig. 14).



RB249A

Fig. 8 Checking Rotor End Clearance

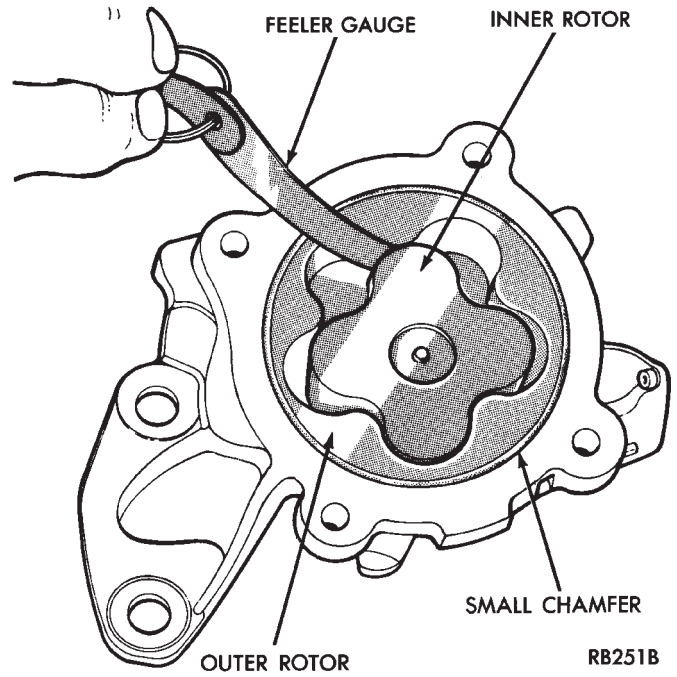

RB251B

Fig. 10 Clearance Between Rotors

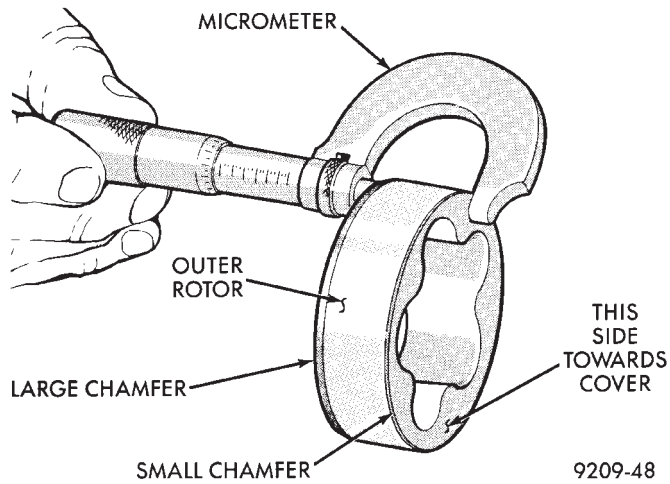

9209-48

Fig. 9 Measuring Outer Rotor

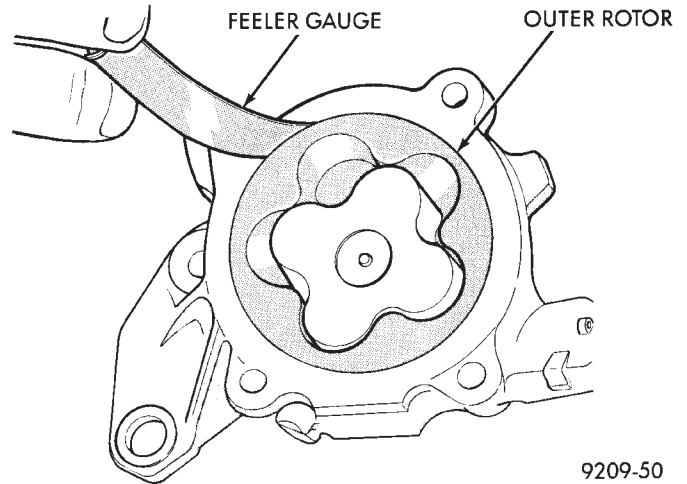

9209-50

Fig. 11 Outer Rotor Clearance

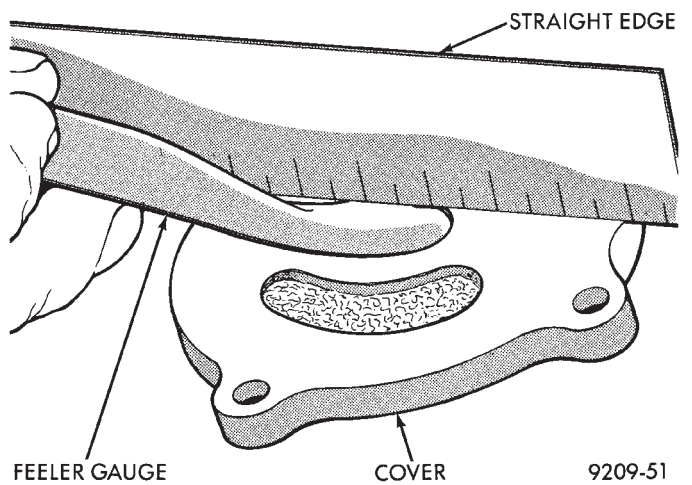

9209-51

Fig. 12 Oil Pump Cover

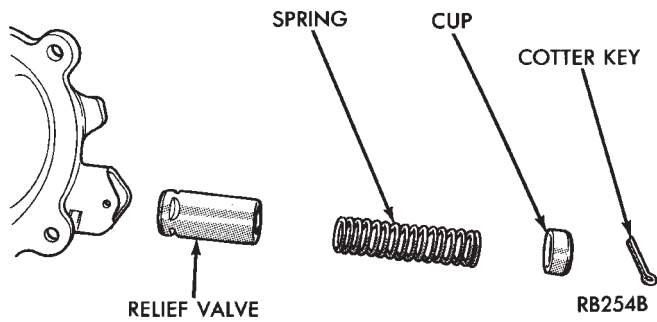
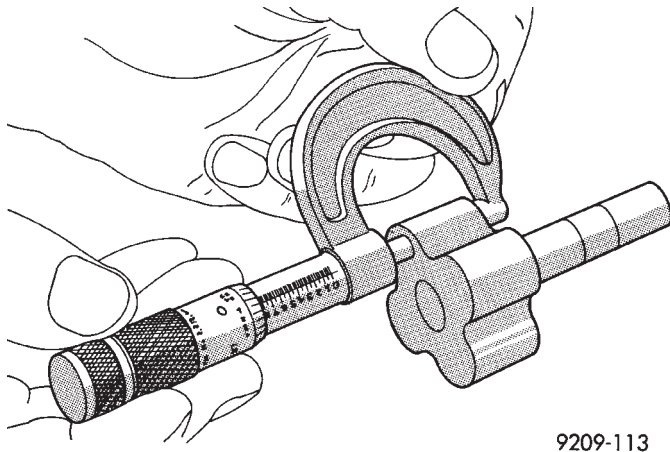

Fig. 13 Oil Pressure Relief Valve



9209-113

Fig. 14 Measuring Inner Rotor Thickness

CHECKING ENGINE OIL PRESSURE

- (1) Remove pressure sending unit and install Special Tool S-94 with gauge assembly C-3292 (Fig. 15).
- (2) Warm engine at high idle until thermostat opens.

CAUTION: If oil pressure is 0 at idle, Do Not Run engine at 3000 RPM

- (3) Oil Pressure: **Curb Idle** 25 kPa (4 psi) minimum
3000 RPM 170-550 kPa (25-80 psi).

OIL FILTER

ANTI-DRAIN BACK VALVE

Installation: Apply liquid (Teflon Type) sealant to valve-to-block threads (Fig. 16). Tighten assembly to 55 N•m (40 ft. lbs.).

FILTER

CAUTION: When servicing the oil filter (Fig. 16) avoid deforming the filter can by installing the remove/install tool band strap against the can-to-

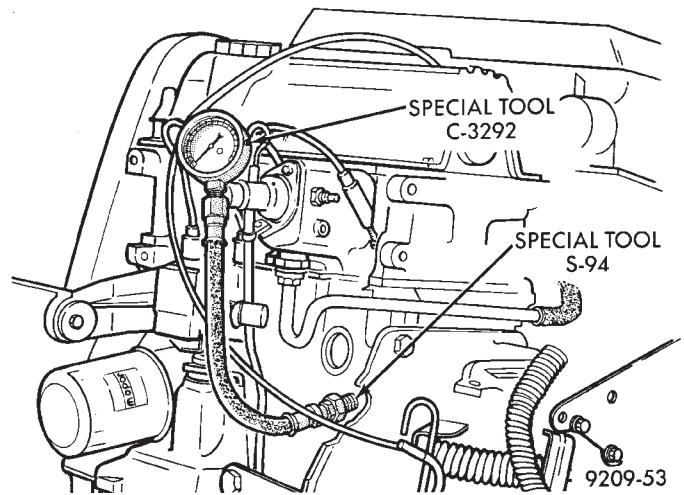
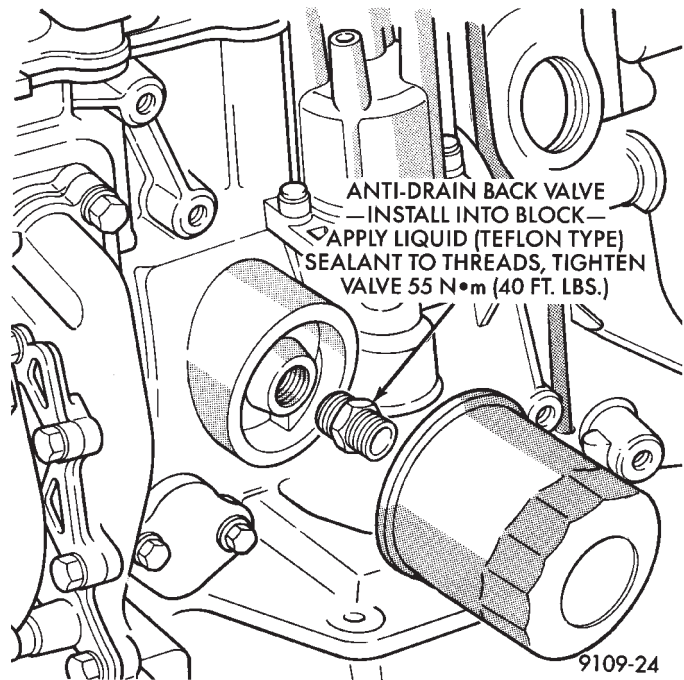

Fig. 15 Checking Oil Pump Pressure—Typical



ANTI-DRAIN BACK VALVE
—INSTALL INTO BLOCK—
APPLY LIQUID (TEFLON TYPE)
SEALANT TO THREADS, TIGHTEN
VALVE 55 N•m (40 FT. LBS.)

9109-24

Fig. 16 Engine Oil Filter and Antidrain Back Valve base lockseam. The lockseam joining the can to the base is reinforced by the base plate.

- (1) Turn counter clockwise to remove.
- (2) To install, lubricate new filter gasket. Check filter mounting surface. The surface must be smooth, flat and free of debris or old pieces of rubber. Screw filter on until gasket contacts base. Tighten to 1 turn.



ENGINE SPECIFICATIONS

| | |
|-----------------------------|--|
| Type | In-line OHV, OHC |
| Number of Cylinders | 4 |
| Bore | 87.5mm (3.44/3.45 in.) |
| Stroke | 104mm (4.09 in.) |
| Compression Ratio | 8.9:1 |
| Firing Order | 1-3-4-2 |
| Basic Ignition Timing | Refer to Emission Control Information Label on Vehicle |

Valve Timing

| | |
|------------------------------|------|
| Intake Valve | |
| Opens (BTDC) | 4° |
| Opens (ATDC) | — |
| Closes (ABDC) | 60° |
| Exhaust Valve | |
| Opens (BBDC) | 40° |
| Closes (ATDC) | 12° |
| Valve Overlap | 8° |
| Intake Valve Duration | 236° |
| Exhaust Valve Duration | 232° |

| Description | Standard Dimension | Service Limit |
|---|--------------------------------------|------------------------------|
| Compression Pressure | — | Minimum 689.5 kPa (100 psi)* |
| Maximum Variation Between Cylinders | — | 25% |
| Valve Clearance—Hot Engine | Hydraulic Lash Adjusters | |
| Flatness of Cylinder Head Gasket Surface | 0.1mm (.004 in.) | |
| Cylinder Head Gasket (Thickness Compressed) | 1.73mm (.068 in.) | |
| Camshaft | | |
| Journal Diameter (All) | 34.939/34.960mm (1.375/1.376 in.) | |
| (Oversize—All) | 35.439/35.460mm (1.395/1.396 in.) | |
| Cam Lobe Wear | — | 0.25mm (.010 in.) |
| End Play | 0.13/0.33mm (.005/.013 in.) | 0.50mm (.020 in.) |
| Valves | | |
| Thickness of Valve Head (Margin) | | |
| Intake | 1.5mm (.06 in.) | .793mm (.03 in.) |
| Exhaust | 1.5mm (.06 in.) | 1.19mm (.05 in.) |
| Valve Stem to Guide Clearance | | |
| Intake | 0.022/0.065mm (.0009/.0026 in.) | |
| Exhaust | 0.076/0.119mm (.0030/.0047 in.) | |
| Valve Spring Free Length | | |
| Standard | 60.8mm (2.39 in.) | |
| Valve Spring Load, Intake and Exhaust | | |
| Valve Open @ 30.99mm (1.22 in.) | | |
| All | 890/961 N (195/215 lbs.) | |
| Valve Close @ 41.91mm (1.65 in.) | | |
| All | 480/534 N (108/120 lbs.) | |
| Valve Spring Perpendicularity | | |
| All: | | |
| Intake and Exhaust | 2.0mm (.079 in.) | 2.0mm (.079 in.) |

*At minimum cranking speed (130 RPM)—starter speed, also See "ENGINE PERFORMANCE" in STANDARD SERVICE PROCEDURES.

ENGINE SPECIFICATIONS (CONT.)

| Description | Standard Dimension | Service Limit |
|--|--------------------------------------|------------------------|
| Intermediate (Accessory) Shaft | | |
| Large Journal | 42.670/42.695mm | |
| Bushing (Large) Inside Diameter | 42.730/42.750mm | |
| Small Journal | 19.670/19.695mm | |
| Bushing (Small) Inside Diameter | 19.720/19.750mm | |
| Piston | | |
| Outside Diameter | | |
| 2.5L Standard | 87.430/87.481mm (3.442/3.444 in.) | |
| Piston Rings | | |
| Ring Side Clearance | | |
| No. 1 Ring—Standard | 0.038/0.078mm (.0015/.0031 in.) | 0.10mm (.004 in.) |
| No. 2 Ring—Standard | 0.038/0.093mm (.0015/.0037 in.) | 0.10mm (.004 in.) |
| Piston Ring End Gap | | |
| No. 1 Ring—Standard | 0.25/0.51mm (.010/.020 in.) | 1.0mm (.039 in.) |
| No. 2 Ring—Standard | 0.28/0.53mm (.011/.021 in.) | 1.0mm (.039 in.) |
| Oil Ring Side Rail—All | 0.38/1.40mm (.015/.055 in.) | 1.88mm (.074 in.) |
| Connecting Rod | | |
| Parallelism and Twist Combined | 0.08mm (.003 in.) | 0.08mm (.003 in.) |
| Connecting Rod Side Clearance | 0.13/0.32mm (.005/.013 in.) | |
| Bearing Clearance—Standard | 0.019/0.087mm (.0008/.0034 in.) | 0.10mm (0.004 in.) |
| Cylinder Bore | | |
| Out of Round | — | .050mm (.002 in.) |
| Bore Taper | — | .125mm (.005 in.) |
| Crankshaft | | |
| Connecting Rod Journal O.D. | 49.979/50.005mm (1.968/1.969 in.) | |
| Main Bearing Journal O.D. | 59.987/60.013mm (2.362/2.363 in.) | |
| Bearing Surface Out-of-Round | 0.008mm (.0003 in.) | 0.013mm (.005 in.) |
| Bearing Surface Taper | 0.008mm (.0003 in.) | 0.01mm (.0004 in.) |
| Main Bearing Clearance | 0.011/.072mm (.0004/.0028 in.) | 0.10mm (.004 in.) |
| End Play | 0.05/0.18mm (.002/.007 in.) | 0.35mm (.014 in.) |
| Oil Pump | | |
| Relief Valve Opening Pressure | 414 kPa (60 psi) | 550 kPa (80 psi) |
| Outer Rotor O.D. to Housing Bore Clearance | 0.25mm (.010 in.) | 0.35mm (.014 in.) |
| Outer Rotor Thickness | 23.98/24.00mm (.944/.945 in.) | 23.96mm (.9435 in.) |
| Inner Rotor to Outer Rotor Tip Clearance | 0.10mm (.004 in.) | 0.20mm (.008 in.) |
| Inner and Outer Rotor to Housing Clearance | 0.03/0.08mm (.001/.003 in.) | 0.09mm (.0035 in.) |
| Pump Cover Flatness | 0.05mm (.002 in. max.) | 0.076mm (.003 in.) |
| Relief Spring Free Length | 49.5mm (1.95 in.) | 49.5mm (1.95 in.) |
| Relief Spring Load | 89 N @ 34mm (20 lbs. @ 1.34 in.) | |
| Oil Pressure Switch Minimum | | |
| Actuating Pressure | 14 kPa (2 psi) | |
| Oil Pressure—All | | |
| Minimum Values— Engine Fully Warmed | | |
| At Curb Idle | 30 kPa (4 psi) | |
| At 3000 RPM | 170-550 kPa (25-80 psi) | |



TORQUE

| DESCRIPTION | TORQUE | DESCRIPTION | TORQUE |
|--|-----------------------|---|-----------------------|
| Balance Shaft Carrier; | | Exhaust Manifold Bolt | 23 N·m (200 in. lbs.) |
| Front Chain Cover Screw | 12 N·m (105 in. lbs.) | Front Crankshaft Oil Seal | |
| Chain Tensioner Adjustment Screw | 12 N·m (105 in. lbs.) | Retainer Screw | 12 N·m (105 in. lbs.) |
| Chain Tensioner Pivot Screw | 12 N·m (105 in. lbs.) | Intake Manifold Bolt | 23 N·m (200 in. lbs.) |
| Chain Snubber Stud and Washer | 12 N·m (105 in. lbs.) | Intermediate Shaft Retainer Screw | 12 N·m (105 in. lbs.) |
| Chain Snubber Nut | 12 N·m (105 in. lbs.) | Intermediate Shaft Sprocket Screw | 88 N·m (65 ft. lbs.) |
| Gear Cover Screw | 12 N·m (105 in. lbs.) | Lower Timing Belt Cover Screw | 4 N·m (40 in. lbs.) |
| Gear (and Sprocket) to Balance Shaft | 28 N·m (250 in. lbs.) | Main Bearing Cap Bolt | 41 N·m (30 ft. lbs.) |
| Sprocket to Crankshaft-Torx Drive | | | + 1/4 Turn |
| Cap Screw | 15 N·m (130 in. lbs.) | Oil Pan Screw (M8 Screws) | 23 N·m (200 in. lbs.) |
| Rear Cover Screw | 12 N·m (105 in. lbs.) | Oil Pan Screw (M6 Screws) | 12 N·m (105 in. lbs.) |
| Carrier-to-Block Bolt | 54 N·m (40 ft. lbs.) | Oil Pump Cover Screw | 12 N·m (105 in. lbs.) |
| Cup Plug | Sealant Loctite 277 | Oil Pan Drain Plug | 27 N·m (240 in. lbs.) |
| Camshaft Bearing Cap Bolt | 25 N·m (215 in. lbs.) | Oil Pump Strainer-to-Cover Screw | 28 N·m (250 in. lbs.) |
| Camshaft Sprocket Bolt | 89 N·m (65 ft. lbs.) | Oil Pump Mounting Screw | 23 N·m (200 in. lbs.) |
| Connecting Rod Bearing Cap Nut | 54 N·m (40 ft. lbs.) | Rear Crankshaft Oil Seal | |
| | +1/4 Turn | Retainer Screw | 12 N·m (105 in. lbs.) |
| Crankshaft Sprocket Bolt | 115 N·m (85 ft. lbs.) | Spark Plug | 27 N·m (20 ft. lbs.) |
| Cylinder Head Cover Screw | 12 N·m (105 in. lbs.) | Thermostat Housing Screw | 28 N·m (250 in. lbs.) |
| Cylinder Head Bolt- 4 Step | | Upper Timing Belt Cover Screw | 4 N·m (40 in. lbs.) |
| Torque Sequence | 61 N·m (45 ft. lbs.) | Water Pump Housing Screw-Upper | 28 N·m (250 in. lbs.) |
| | 89 N·m (65 ft. lbs.) | Water Pump Housing Screw-Lower | 54 N·m (40 ft. lbs.) |
| | 89 N·m (65 ft. lbs.) | | |
| | + 1/4 Turn | | |

All fasteners should be thoroughly cleaned and lightly oiled

3.0L ENGINE

INDEX

| | page | | page |
|--|------|---|------|
| Accessory Drive Belt Service | 54 | Engine Mounts | 52 |
| Auto Lash Adjuster | 59 | Engine Specifications | 79 |
| Camshaft Service | 60 | General Information | 50 |
| Checking Engine Oil Pressure | 77 | Oil Filter and Bracket | 78 |
| Crankshaft and Cylinder Block, Assembly Service .. | 70 | Oil Pan | 76 |
| Cylinder Block | 73 | Oil Pump Service | 76 |
| Cylinder Head | 62 | Piston and Connecting Rod Assembly Service .. | 66 |
| Cylinder Head and Camshaft Service | 59 | Timing Belt Inspection—In Vehicle | 55 |
| Engine Assembly | 53 | Timing Belt Service | 56 |
| Engine Lubrication System | 75 | Valve Service | 64 |

3.0L ENGINE

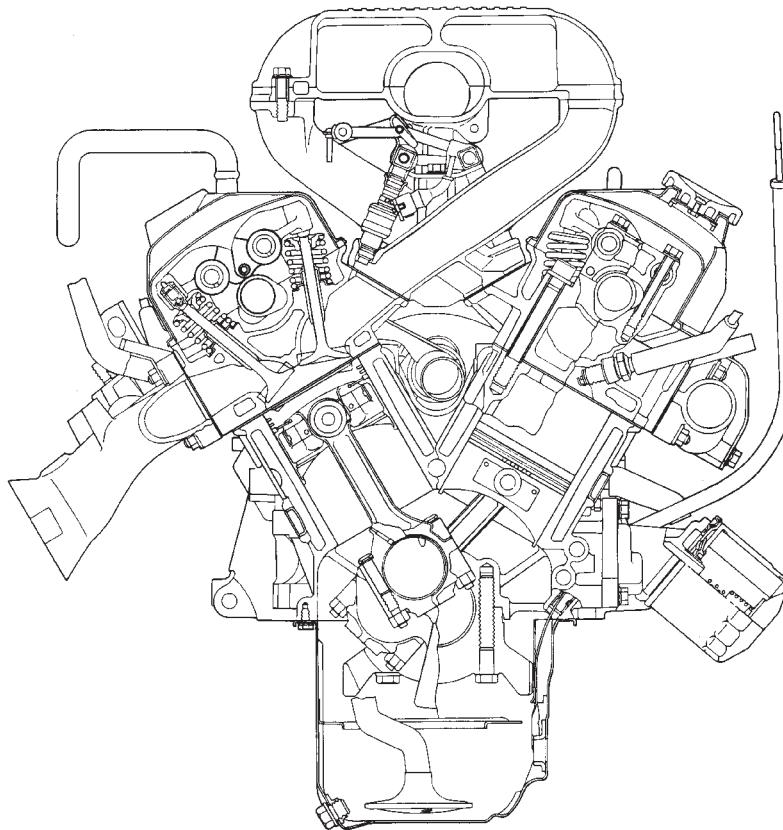

9009-43

GENERAL INFORMATION

ENGINE IDENTIFICATION NUMBER OR CODE

The engine identification number is located on the rear of the cylinder block just below the cylinder head (Fig. 1).

BLOCK: The cylinder block is a light weight design created by reducing thickness in many parts and a short 10 mm (3/8 inch) block skirt. High rigidity is provided with ribs cast in the outer wall, a full length water jacket, and a monoblock or beam type, main

bearing cap. This single unit four bearing cap is designed to control vibration of the cylinder block partition walls.

CRANKSHAFT: A six throw, five weight crankshaft is supported by four main bearings with number three being the thrust bearing. The six separate connecting rod throws pins reduce torque fluctuations while a torsional vibration damper is used to control torsion caused vibration of the crankshaft. Rubber lipped seals are used at front and rear. The front seal is retained in the oil pump case and the rear is retained in a block-mounted housing.

SPECIFICATIONS

3.0L V-6 ENGINE

| | |
|---------------------------|---|
| Type | 60°V SOHC (Per Bank) |
| Bore | 91.1 mm (3.587 Inch) |
| Stroke | 76.0 mm (2.992 Inch) |
| Compression Ratio | 8.85:1 |
| Displacement | 3.0 Liters (181 Cubic Inch) |
| Torque | 170 Lb. Ft. @ 2800 RPM |
| Firing Order | 1-2-3-4-5-6 |
| Lubrication | Pressure Feed-Full Flow Filtration (Direct Crankshaft Driven Pump) |
| Engine Oil Capacity | 4.25 Liter (4.5 Qts.) Including Oil Filter, 3.8 Liter (4.0 Qts.) Without Oil Filter. |
| Cooling System | Liquid Cooled-Forced Circulation (Pump-Timing Belt Driven) |
| Cylinder Block | Cast Iron |
| Crankshaft | Cast (Ductile Cast Iron) |
| Cylinder Head | Aluminum Alloy |
| Connecting Rods | Forged Steel |
| Pistons | Aluminum Alloy (w/Strut) |

9209-61

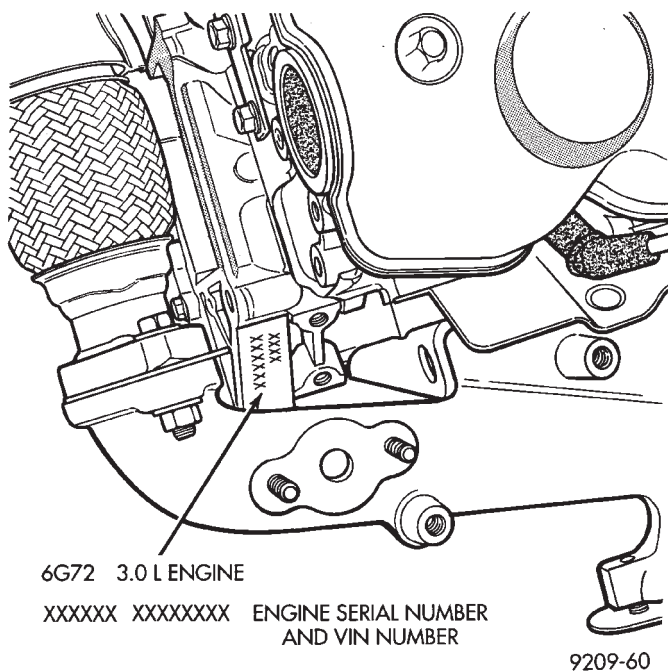
**Fig. 1 Engine Identification**

PISTONS: Are aluminum alloy with a steel strut, short height, and thin wall so as to be autothermic and light weight. The piston head with valve recesses, in combination with the cylinder head, forms a compact spherical head with clearance for total valve lift with pistons at top dead center. The piston skirt, top and second ring lands are finished with curvilinear tapered roughness for oil retention and high resistance to scuffing. Piston pins, press-fitted into place, join the pistons to the connecting rods.

CYLINDER HEAD: The alloy cylinder heads feature cross-flow type intake and exhaust ports. Valve

guides and inserts are hardened cast iron. Valves of heat resistance steel are arranged in a V with each camshaft on center. To improve combustion speed the chambers are a compact spherical design with a squish area of approximately 30 percent of the piston top area. The cylinder heads are common to either cylinder bank by reversing the direction of installation.

CAMSHAFTS: Two overhead camshafts provide valve actuation, one front (radiator side of cylinder bank) and one rear. The front camshaft is provided with a distributor drive and is longer. Both camshafts are supported by four bearing journals, thrust for the front camshaft is taken at journal two and the rear at journal three. Front and rear camshaft driving sprockets are interchangeable. The sprockets and the engine water pump are driven by a single notched timing belt.

ROCKER ARM SHAFTS: The shafts are retained by the camshaft bearing journal caps. Four shafts are used, one for each intake and exhaust rocker arm assembly on each cylinder head. The hollow shafts provide a duct for lubricating oil flow from the cylinder head to the valve mechanisms.

ROCKER ARMS: Are of light weight die-cast with roller type follower operating against the cam shaft. The valve actuating end of the rocker arms are machined to retain hydraulic lash adjusters, eliminating valve lash adjustment.

VALVES: Are made of heat resistant steel and are further treated to resist heat.

VALVE SPRINGS: Are especially designed to be short. The valve spring wire cross-section is oval

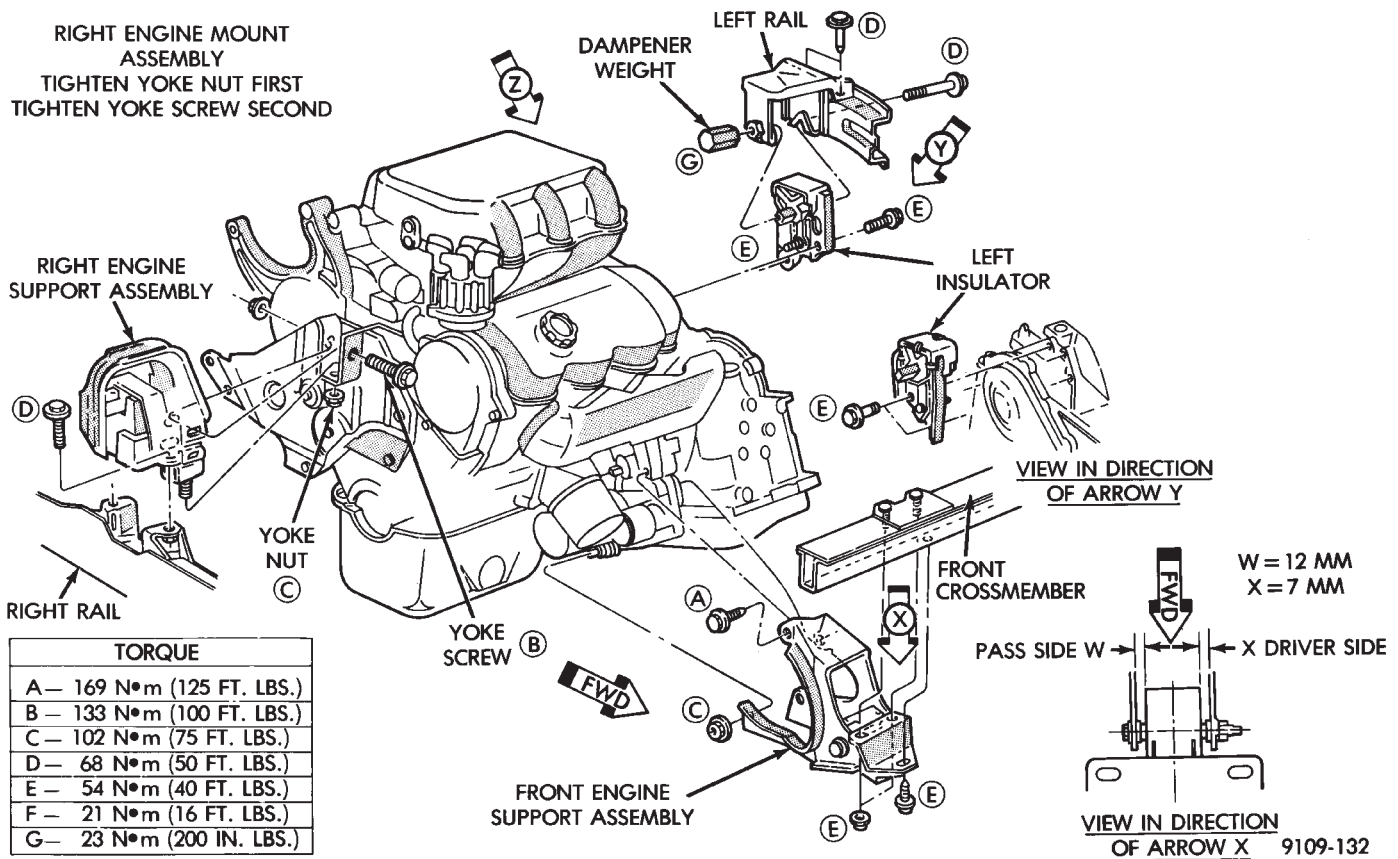

Fig. 2 Engine Mounting

shaped and provides the same spring tension as longer springs. Valve spring retainers, locks and seals are conventional.

INTAKE MANIFOLD: The aluminum alloy manifold is a cross type with long runners to improve inertia. The runners, attaching below at the cylinder head, also attach above and support an air plenum. The air plenum chamber absorbs air pulsations created during the suction phase of each cylinder.

EXHAUST MANIFOLDS: Both manifolds are a log style made of ductile cast iron. Exhaust gasses, collected from the front cylinder bank, leave the front manifold through an end outlet and are fed through an upper crossover tube to the rear manifold. The collected exhaust from both manifolds are combined, and exit to the exhaust pipe through an articulated joint.

ENGINE LUBRICATION: System is a full flow filtration, pressure feed type. The oil pump is mounted in the chaincase cover. The pump inner rotor is driven by the crankshaft. The engine oil pan contains a baffle plate to control oil level fluctuation during engine operation.

ENGINE MOUNTS

REMOVAL AND INSTALLATION

RIGHT SIDE MOUNT

- (1) Remove the right engine mount insulator vertical fasteners from frame rail.
- (2) Remove the load on the engine motor mounts by carefully supporting the engine and transmission assembly with a floor jack.
- (3) Remove the thru bolt from the insulator assembly. Remove insulator.
- (4) Reverse removal procedure for installation. Refer to (Fig. 2) for bolt tightening specifications.
- (5) Engine mount adjustment, Refer to Engine Mount Insulator Adjustment of this section.

FRONT MOUNT

- (1) Support the engine and transmission assembly with a floor jack so it will not rotate.
- (2) Remove the thru bolt from the insulator and front crossmember mounting bracket.
- (3) Remove the front engine mount bracket to front crossmember screws and nuts. Remove the insulator assembly.
- (4) Reverse removal procedure for installation. Refer to (Fig. 2) for bolt tightening specifications.
- (5) Engine mount adjustment, Refer to Engine Mount Insulator Adjustment of this section.

LEFT SIDE MOUNT

- (1) Raise vehicle on hoist and remove left front wheel.
- (2) Remove inter splash shield.
- (3) Support the transmission with a transmission jack.
- (4) Remove the insulator thru bolt from the mount.
- (5) Remove the transmission mount fasteners and remove mount.
- (6) Reverse removal procedure for installation. Refer to (Fig. 3) for bolt tightening specifications.
- (7) Engine mount adjustment, Refer to Engine Mount Insulator Adjustment of this section.

ENGINE MOUNT RUBBER INSULATORS

Insulator location on frame rail (right side) and transmission bracket (left side) are adjustable to allow right/left drive train adjustment in relation to drive shaft assembly length.

Check and reposition right engine mount insulator (left engine mount insulator is floating type and will adjust automatically (Fig. 3). Adjust drive train position, if required, for the following conditions:

- Drive shaft distress: See Driveshafts in Suspension, Group 2.
- Any front end structural damage (after repair).
- Insulator replacement.

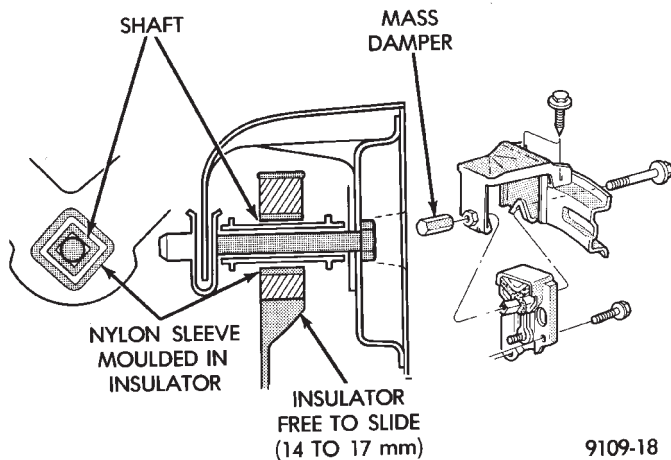

Fig. 3 Left Insulator Movement

ENGINE MOUNT INSULATOR ADJUSTMENT

- (1) Remove the load on the engine motor mounts by carefully supporting the engine and transmission assembly with a floor jack.
- (2) Loosen the right engine mount insulator vertical fasteners, and the front engine mount bracket to front crossmember screws and nuts.

Left engine mount insulator is sleeved over shaft and long support bolt to provide lateral movement adjustment with engine weight removed or not.

- (3) Pry the engine right or left as required to achieve the proper drive shaft assembly length. See Drive

Shaft in Suspension Group 2 for driveshaft identification and related assembly length measuring.

- (4) Tighten right engine mount insulator vertical bolts to 37 N•m (27 ft. lbs.). Then tighten front engine mount screws and nuts to 54 N•m (40 ft. lbs.) and center left engine mount insulator.
- (5) Recheck drive shaft length.

ENGINE ASSEMBLY

REMOVAL

- (1) Disconnect battery.
- (2) Mark hood position at hinges and remove hood.
- (3) Drain cooling system. Refer to Cooling System Group 7 for draining procedure.
- (4) Disconnect all electrical connections.
- (5) Remove coolant hoses from radiator and engine.
- (6) Remove radiator and fan assembly.
- (7) See Fuel System Group 14, For procedures to release fuel pressure, disconnect fuel lines and accelerator cable.
- (8) Remove air cleaner assembly.
- (9) Hoist vehicle and drain engine oil.
- (10) Remove air conditioning compressor mounting bolts and set compressor aside.
- (11) Disconnect exhaust pipe at manifold.
- (12) Remove transmission inspection cover and mark flex plate to torque converter position.
- (13) Remove screws holding torque converter to flex plate and attach C-clamp on bottom of converter housing to prevent torque converter from coming out.
- (14) Remove power steering pump mounting bolts and set pump aside.
- (15) Remove two lower transmission to block screws.
- (16) Remove starter.
- (17) Lower vehicles and disconnect vacuum lines and ground strap.
- (18) Install transmission holding fixture.
- (19) Attach engine lifting hoist and support engine.
- (20) Remove upper transmission case to block bolts.
- (21) See Engine Mounting in (Fig. 2) and separate mount/insulators as follows:
 - (a) Mark RIGHT insulator on right rails supports. Remove insulator to rails screws.
 - (b) Remove FRONT engine mount through bolt and nut.
 - (c) Remove LEFT insulator through bolt from inside wheelhouse or insulator bracket to transmission screws.
- (22) Remove engine.

| TORQUE | |
|--------|-----------------------|
| A— | 54 N•m (40 FT. LBS.) |
| B— | 40 N•m (30 FT. LBS.) |
| C— | 28 N•m (250 IN. LBS.) |

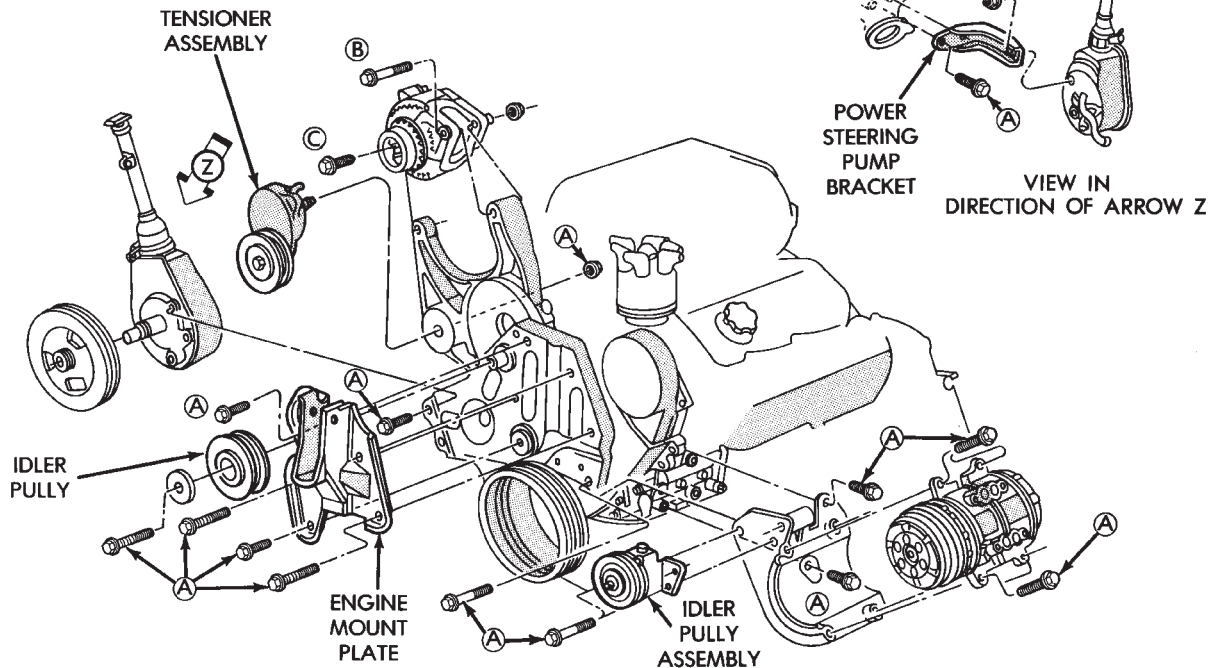

9109-32

Fig. 4 Accessories Mounting Brackets

INSTALLATION

- (1) Attach hoist and lower engine into engine compartment.
- (2) Align engine mounts and install but **do not tighten** until all mounting bolts have been installed. Tighten bolts to torque specified in (Fig. 2).
- (3) Install transmission case to cylinder block, tighten bolts to 102 N•m (75 ft. lbs.) torque.
- (4) Remove engine hoist and transmission holding fixture.
- (5) Remove C clamp from torque converter housing. Align flex plate to torque converter and install mounting screws. Tighten to 75 N•m (55 ft. lbs.)
- (6) Install transmission inspection cover.
- (7) Connect exhaust system at manifold.
- (8) Install starter.
- (9) Install power steering pump and air conditioning compressor. For belt installation Refer to Accessory Belt Drive in Cooling System Group 7.
- (10) Lower vehicle and connect all vacuum lines.
- (11) Connect all electrical connections including ground strap.
- (12) Connect fuel lines and accelerator cable.
- (13) Install radiator and fan assembly. Connect fan motor electrical lead. Install radiator hoses. Fill cooling system. Refer to Cooling System Group 7 for filling procedure.

- (14) Fill engine crankcase with proper oil to correct level.
- (15) Install hood.
- (16) Connect battery.
- (17) Start engine and run until operating temperature is reached.
- (18) Adjust transmission or linkage if necessary.

ACCESSORY DRIVE BELT SERVICE

REMOVAL

- (1) Loosen adjusting lock nut (Fig. 6).
- (2) Turn adjusting jack screw counterclockwise to reduce belt tension. Remove belt.

BELT REPLACEMENT UNDER ANY OR ALL OF THE FOLLOWING CONDITIONS IS REQUIRED, EXCESSIVE WEAR, FRAYED CORDS OR SEVERE GLAZING.

V-RIBBED BELT SYSTEM WITH BACK DRIVE PULLEY MAY DEVELOP MINOR CRACKS ACROSS THE RIBBED SIDE (DUE TO REVERSE BENDING). THESE MINOR CRACKS ARE CONSIDERED NORMAL AND ACCEPTABLE. CRACKS PARALLEL ARE NOT.

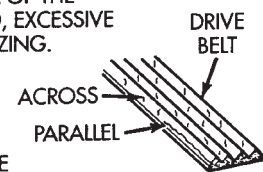

DO NOT USE ANY TYPE OF BELT DRESSING OR RESTORER ON V-RIBBED BELTS.

9207-16

Fig. 5 Drive Belt Inspection

- (3) Inspect drive belt for wear and damage (Fig. 5).
- (4) Installation: Adjust belt tension to 5/16 deflection between pulleys (Fig. 6).
- (5) Install breaker bar into 1/2 square opening in tensioner.
- (6) Rotate tensioner counterclockwise to remove and install belt (Fig. 7).

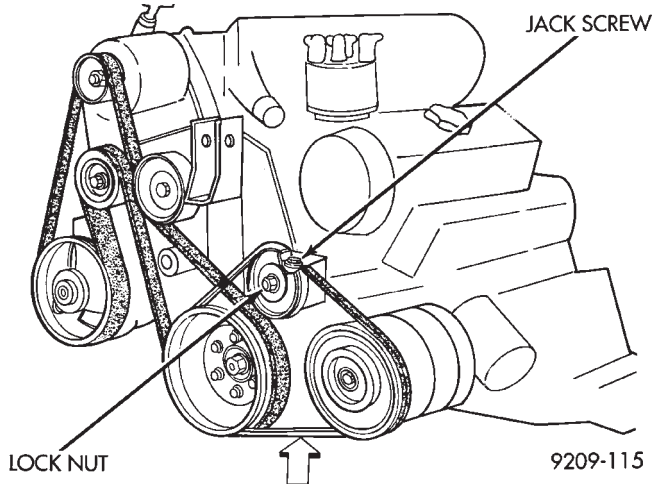

Fig. 6 Air Conditioning Belt

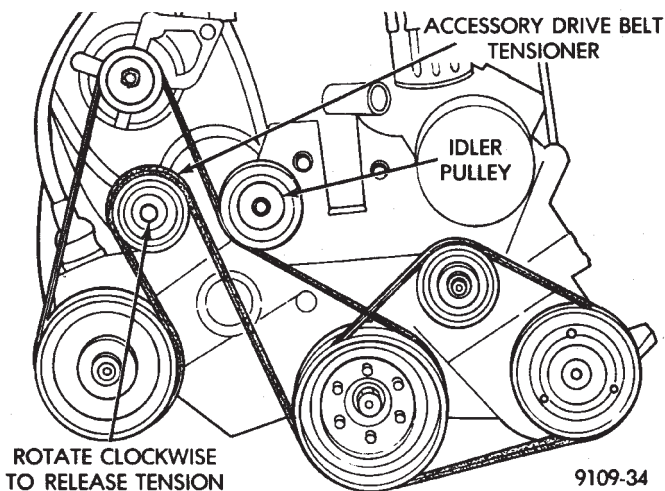

Fig. 7 Alternator/Power Steering Belt

ENGINE MOUNT BRACKET

REMOVAL

- (1) Remove air conditioning compressor to mounting bracket screws and lay compressor aside (Fig. 4).
- (2) Remove screws attaching air conditioning compressor mounting bracket and adjustable drive belt tensioner from block and engine mounting bracket. Remove both assemblies.
- (3) Remove steering pump/alternator belt tensioner mounting bolt and remove automatic belt tensioner.
- (4) Remove two steering pump to engine mounting bracket screws and one rear support lock nut.
- (5) Lay power steering pump aside.
- (6) Raise vehicle and remove right inner splash shield (Fig. 8).

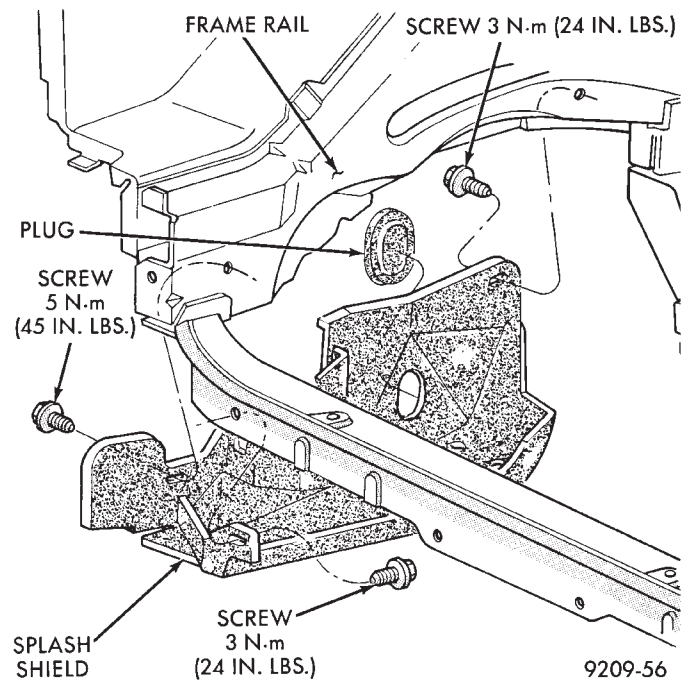

Fig. 8 Right Inner Splash Shield—Typical

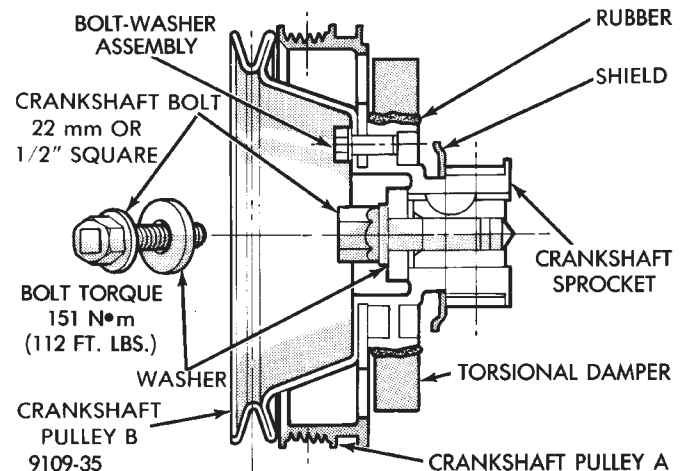

Fig. 9 Crankshaft Drive Pulleys

- (7) Remove crankshaft drive pulleys and torsional damper (Fig. 9).
- (8) Lower vehicle and place a jack under engine.
- (9) Separate engine mount insulator from engine mount bracket (Fig. 10). Raise engine slightly.
- (10) Remove engine mount bracket (Fig. 10).
- (11) Remove timing belt covers (Fig. 11).

TIMING BELT INSPECTION—IN VEHICLE

- (1) Remove the upper front outer timing belt cover by loosening the three attaching bolts. (Fig. 11).
- (2) Inspect both sides of the timing belt drive & back. Replace belt if any of the following conditions exist.
 - Hardening of back rubber back side is glossy without resilience and leaves no indent when pressed with fingernail.

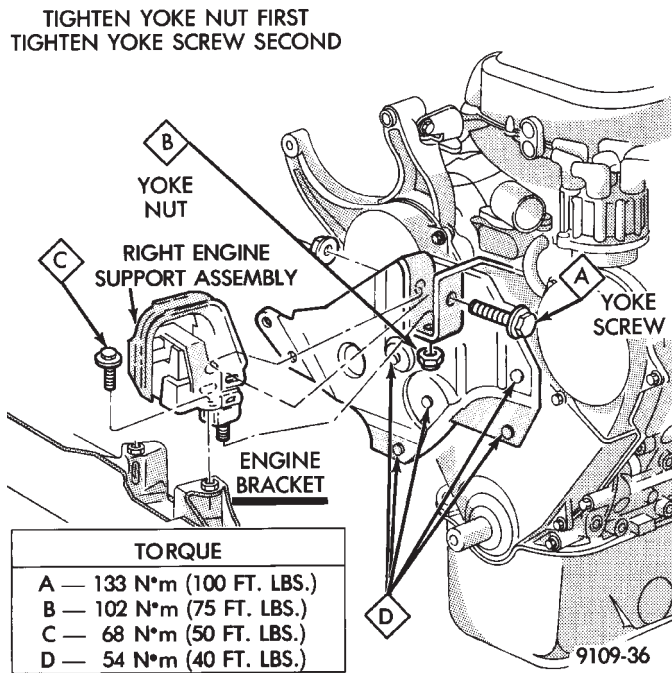

Fig. 10 Right Engine Mount and Engine Mount Bracket

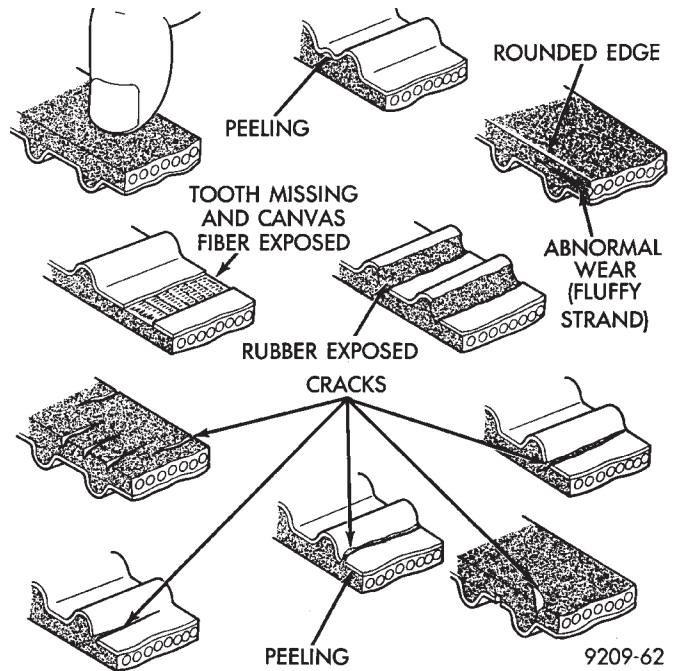

Fig. 12 Timing Belt Inspection

TIMING BELT SERVICE

REMOVAL

- (1) Mark belt running direction for installation (Fig. 14).
- (2) Loosen timing belt tensioner bolt (Fig. 16) and remove timing belt.
- (3) Remove crankshaft sprocket flange shield (Fig. 9).

CAMSHAFT SPROCKETS

REMOVAL

- (1) Hold camshaft sprocket with Spanner Tool MB990775 loosen and remove bolt and washer (Fig. 15).
- (2) Remove camshaft sprocket from camshaft.

INSTALLATION

- (1) Place camshaft sprocket on camshaft.
- (2) Install bolt and washer to camshaft. Using Spanner Tool MB990775 hold camshaft sprocket and torque bolt to 95 N•m (70 ft. lbs.) (Fig. 15).

TIMING BELT TENSIONER

- (1) Install timing belt tensioner and tensioner spring.
- (2) Hook spring upper end to water pump pin and lower end to tensioner bracket with hook out (Fig. 16).
- (3) Turn timing belt tensioner counter-clockwise full travel in adjustment slot and tighten bolt to temporarily hold this position (Fig. 17).

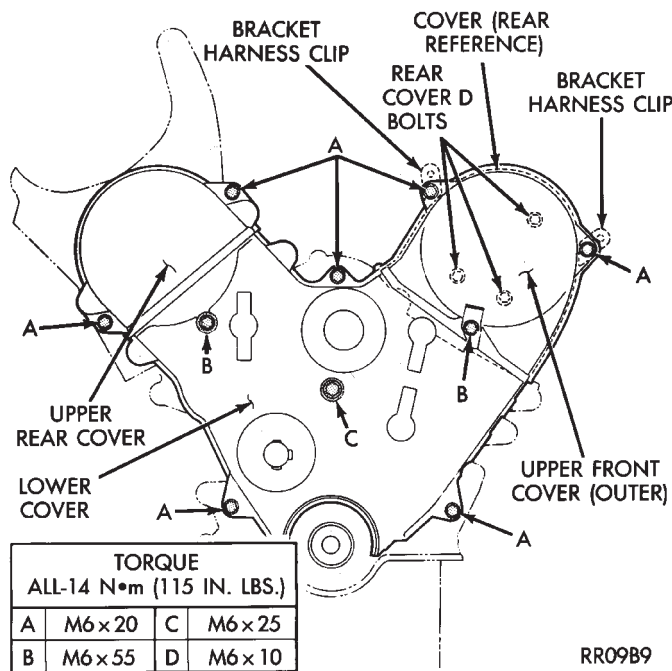

Fig. 11 Timing Belt Covers

- Cracks on rubber back.
 - Cracks or peeling of canvas.
 - Cracks on rib root.
 - Cracks on belt sides.
 - Missing teeth.
 - Abnormal wear of belt sides. The sides are normal if they are sharp as if cut by a knife (Fig. 12).
- (3) If none of the above conditions are seen on the belt, the belt cover can be reinstalled.

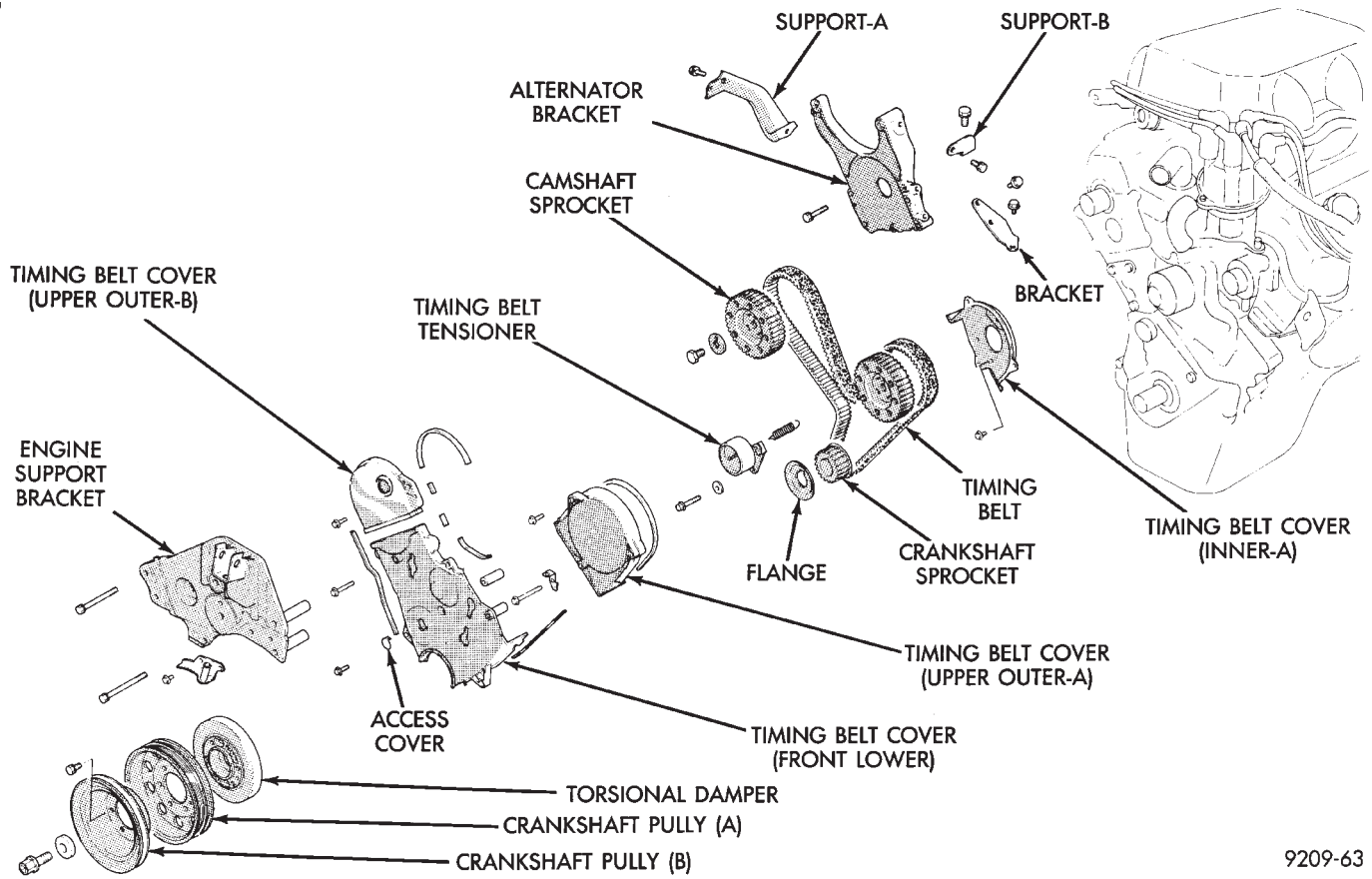

Fig. 13 Timing Belt System

9209-63

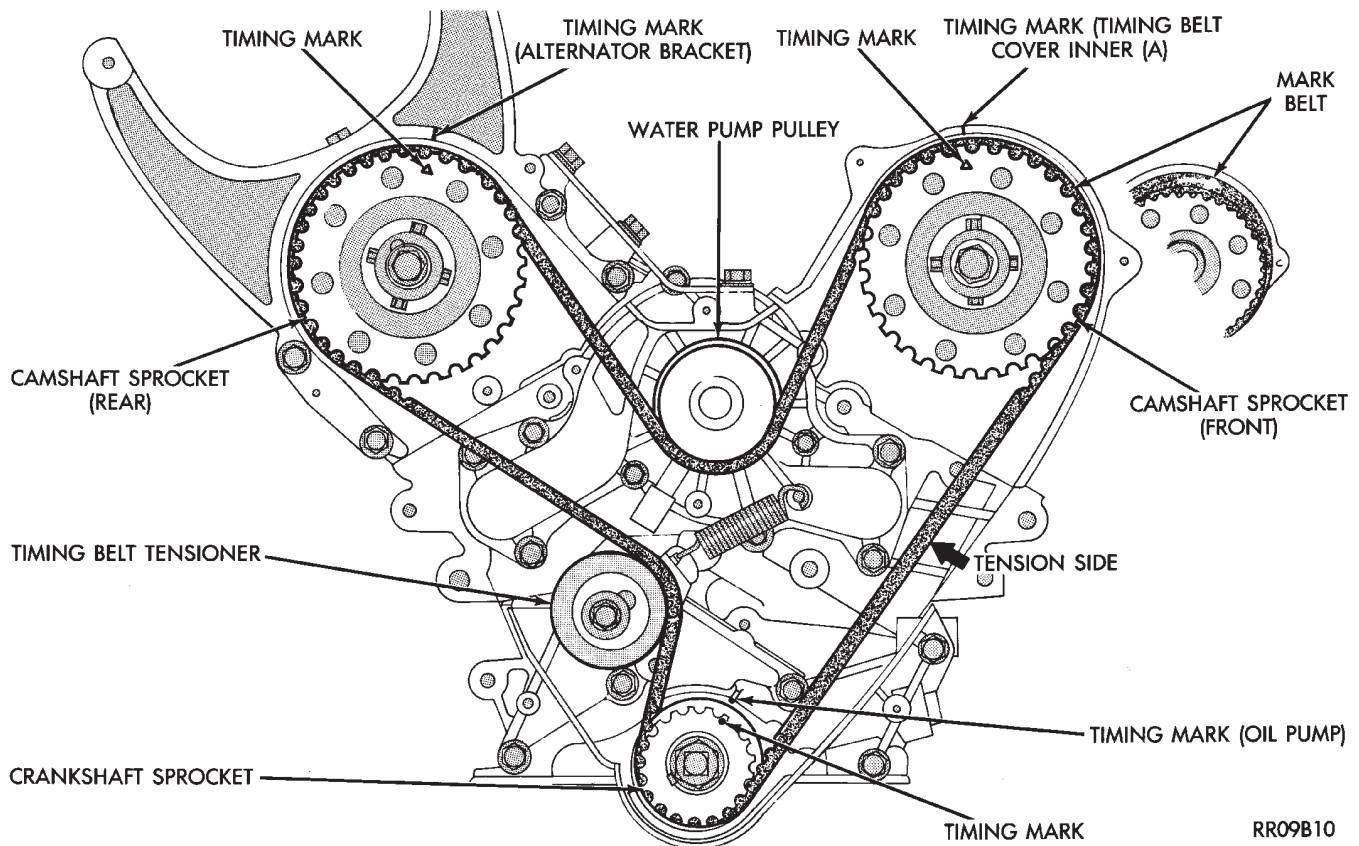

Fig. 14 Timing Belt EEngine Sprocket Timing

RR09B10

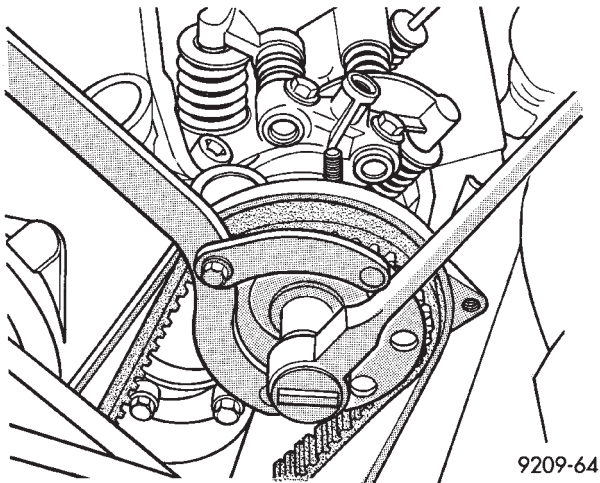

Fig. 15 Camshaft Sprockets

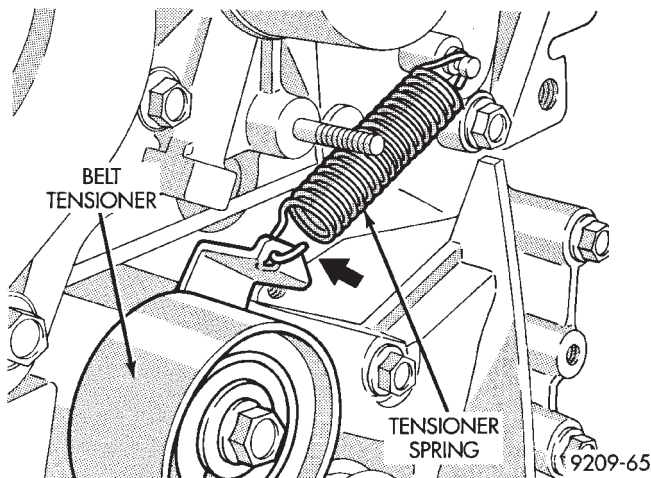

Fig. 16 Timing Belt Tensioner

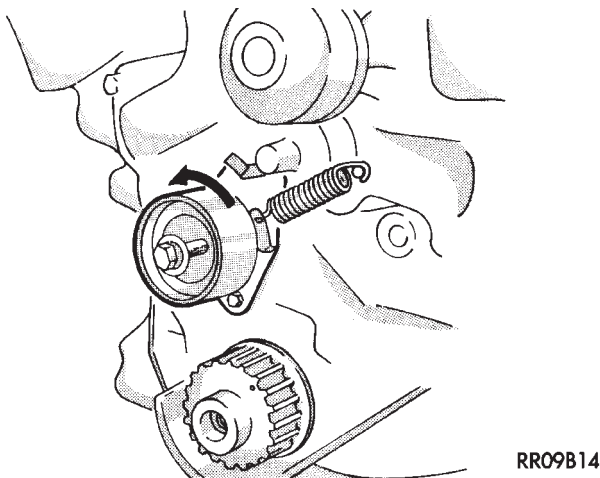

Fig. 17 Positioning Belt Tensioner

INSTALLATION—TIMING BELT

(1) Install timing belt on crankshaft sprocket first and while keeping belt tight on tension side (Fig. 14) install belt on the front (radiator side) camshaft sprocket.

(2) Then, install on the water pump pulley and on

the rear camshaft sprocket and finally on the timing belt tensioner.

(3) Apply rotating force to the front camshaft sprocket in opposite direction to tension the belt tension side and check that all timing marks are lined up (Fig. 14).

(4) Install crankshaft sprocket flange (Fig. 13).

(5) Loosen tensioner bolt and allow spring to tension timing belt.

(6) Turn crankshaft two full turns in clockwise direction. **Turn smoothly and in clockwise direction ONLY.**

(7) Again line up the timing marks on the sprockets and tighten the timing belt tensioner locking bolt to 25 N•m (250 in. lbs.) torque.

(8) Reassembly belt covers, engine Bracket, Insulator, crankshaft pulleys, accessories and accessory drive belts in reverse order.

CYLINDER HEAD AND CAMSHAFT SERVICE

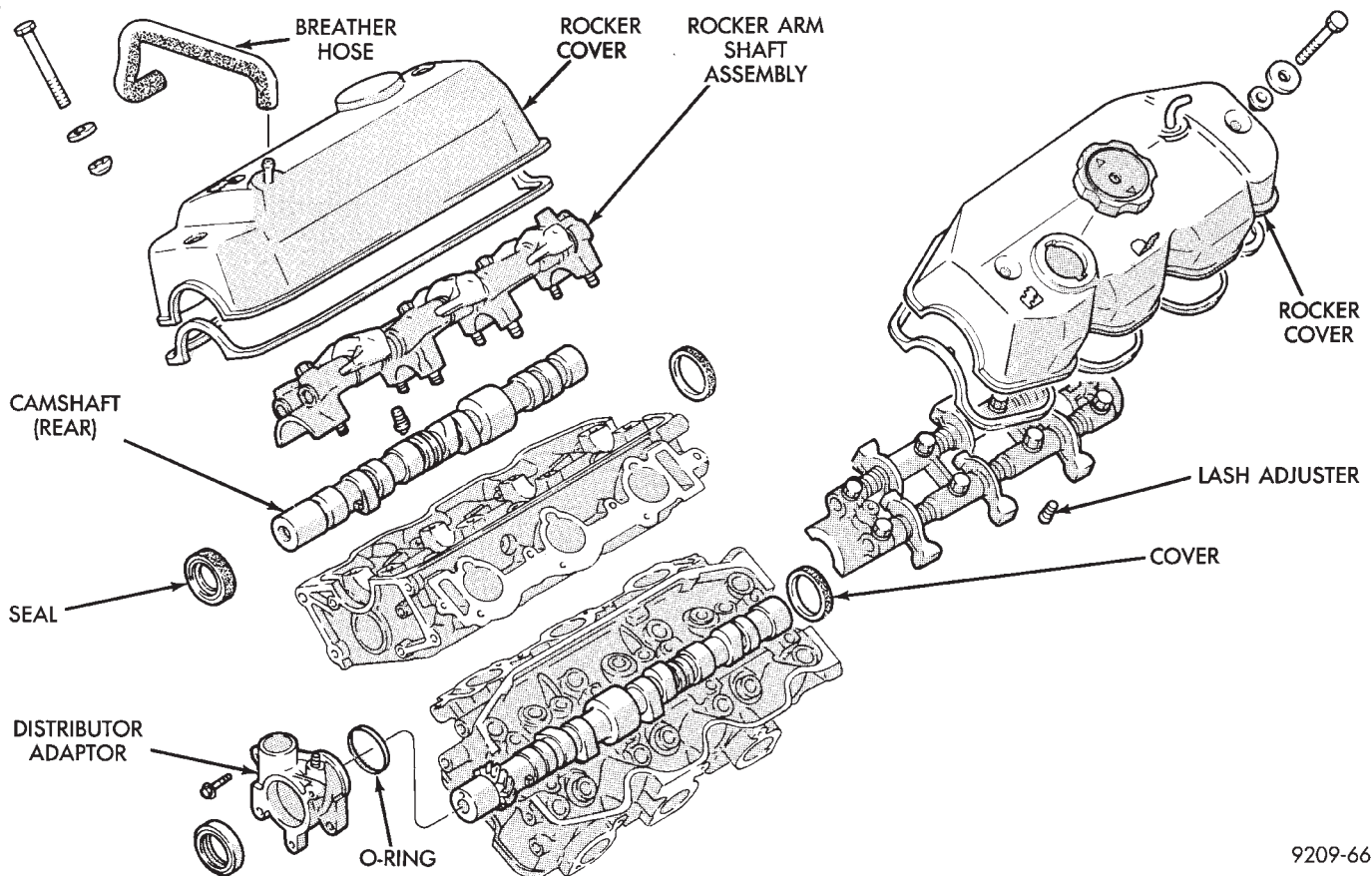

9209-66

Fig. 1 Cylinder Head-Camshaft-Valves

CYLINDER HEAD COVER

REMOVAL

- (1) Remove air cleaner assembly.
- (2) Disconnect battery and relocate spark plug wires.
- (3) Remove vacuum connections.
- (4) Remove rocker cover screws and remove cover (Fig. 2).

INSTALLATION

- (1) Clean cylinder head and cover mating surfaces. Install new gasket.
- (2) See (Fig. 2) and apply sealant such as Mopar Silicone Rubber Adhesive Sealant to cover ends.
- (3) Install cover and tighten cover bolt washer and gasket assembly to 10 N•m (88 in. lbs.).

AUTO LASH ADJUSTER

The automatic lash adjusters are precision units installed in machined openings in the valve actuating ends of the rocker arms. Do not disassemble the auto lash adjuster.

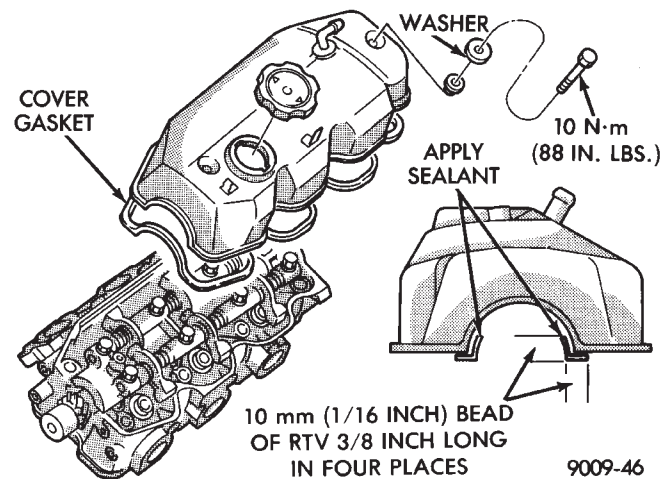

9009-46

Fig. 2 Rocker Cover

FUNCTION CHECK

Check auto adjusters for free play by inserting a small wire through the air bleed hole in the rocker arm and **VERY LIGHTLY** push the auto adjuster ball check down (Fig. 3). While lightly holding the check ball down move the rocker up and down to check for free play. If there is no play replace the adjuster.

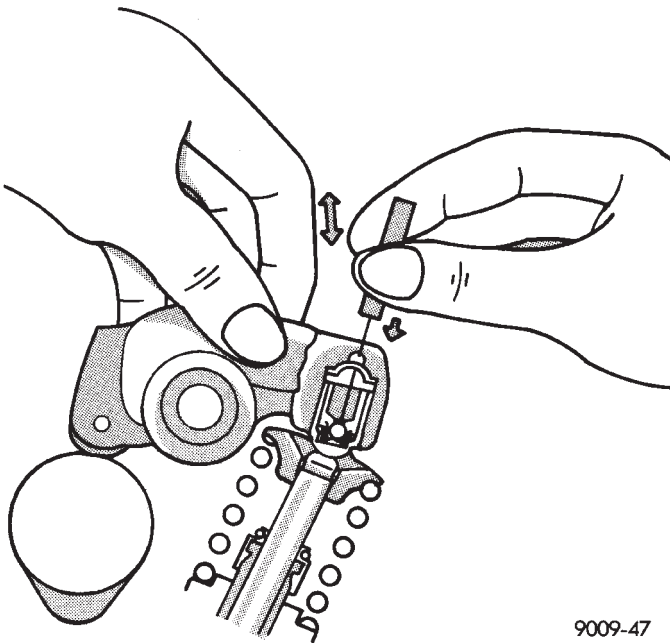

9009-47

Fig. 3 Auto Lash Adjuster Check

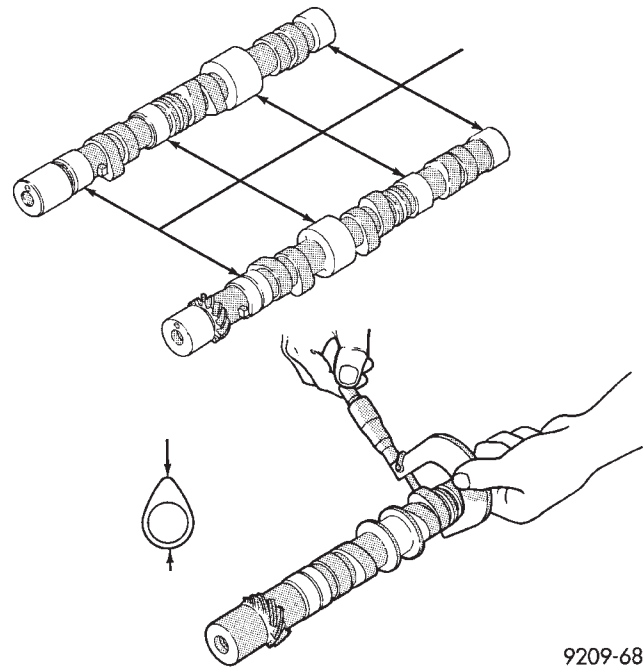

9209-68

Fig. 5 Check Camshafts

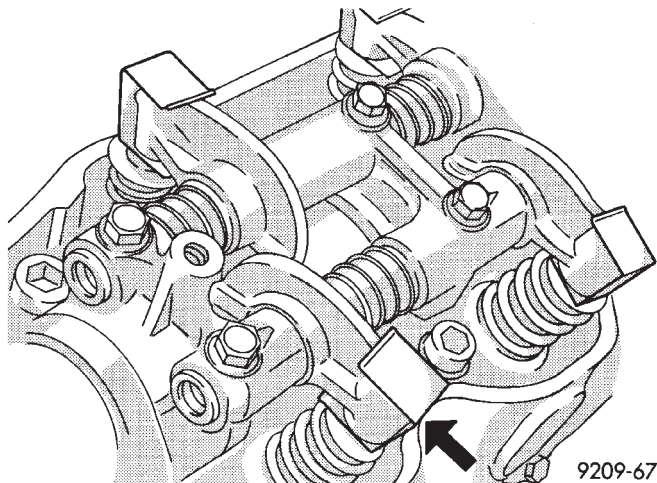

9209-67

Fig. 4 Auto Lash Adjuster Retainers

CAMSHAFT SERVICE

SEE AUTO LASH ADJUSTER FUNCTION CHECK BEFORE DISASSEMBLY

REMOVAL

- (1) Install auto lash adjuster retainers. (Fig. 4).
- (2) Remove distributor extension (Fig. 1).
- (3) When removing camshaft bearing caps do not remove the bolts from the bearing caps. Remove the rocker arm, rocker shafts **and** bearing cap as an assembly.

CAMSHAFT INSPECTION

- (1) Inspect camshaft bearing journals for damage and binding (Fig. 5). If journals are binding, also check the cylinder head for damage (Fig. 1). Also check cylinder head oil holes for clogging.

- (2) Front cylinder head camshaft check the tooth surface of the distributor drive gear teeth of the camshaft and replace if abnormal wear is evident (Fig. 5).

- (3) Check the cam surface for abnormal wear and damage and replace if defective. Also measure the cam height (Fig. 5) and replace if out of limit, standard value is 41.25 mm (1.624 inch), wear **limit** is 40.75 mm (1.604 inch).

CAMSHAFT INSTALL

Lubricate camshaft journals and cams with engine oil and install camshaft on cylinder head.

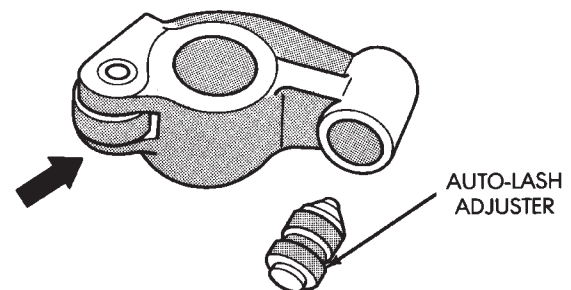

9009-48

Fig. 6 Inspect Rocker Arms

ROCKER ARMS

- (1) Check rocker arms for wear or damage (Fig. 6). Replace as necessary. Also see Auto Lash Adjuster.

ROCKER ARM SHAFTS

The rocker arm shaft is hollow and is used as a lubrication oil duct. The rocker arm shaft on the **inlet**

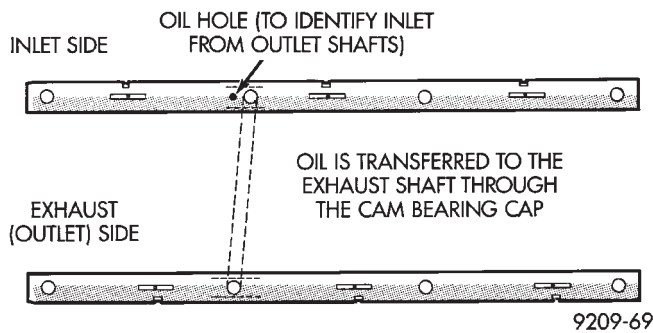

Fig. 7 Rocker Arm Shaft Identification

side has a 3mm diameter oil passage hole from the cylinder head. The **exhaust side does not** have this oil passage (Fig. 7).

(1) Check the rocker arm mounting portion of the shafts for wear or damage. Replace if heavily damaged or worn.

(2) Check oil holes for clogging with small wire, clean as required (Fig. 7).

REASSEMBLE

ARROW MARK (BEARING CAP)

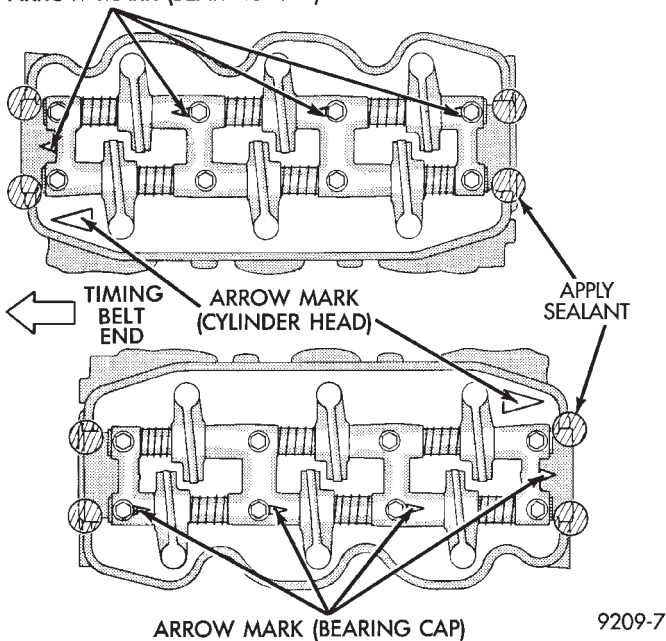

Fig. 8 Camshaft Bearing Caps Position

(1) Align the camshaft bearing caps with arrows (depending on cylinder bank) directed as shown in (Fig. 8) and in numerical order.

Identify number one bearing cap number one and number four caps are similar (Fig. 9).

(2) Install rocker shafts into bearing cap number one with end notches positioned as shown in (Fig. 9) that the machined portion of the rocker shaft is facing down.

(3) Insert attaching bolts to retain assembly.

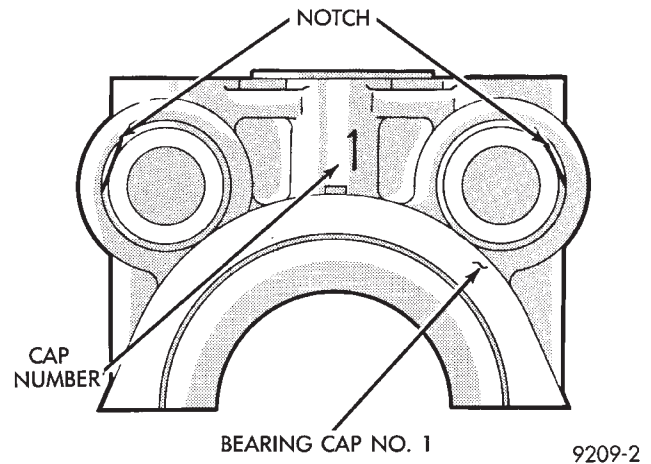

Fig. 9 Number One Camshaft Bearing Cap

ASSEMBLE ROCKER ASSEMBLY

Install the rocker arms, bearing caps and springs. **Springs are the same and can be used at all locations** on the rocker arm shafts (Figs. 8 and 10). Insert bolts in number four bearing cap to retain assembly.

INSTALL ROCKER ARM SHAFT ASSEMBLY

(1) Apply Mopar Silicone Rubber Adhesive Sealant at bearing cap ends as shown in (Fig. 8).

(2) Install the rocker arm shaft assembly making sure that the arrow mark on the bearing cap and the arrow mark on the cylinder head are in the same direction (Fig. 8).

The direction of arrow marks on the front and rear assemblies are opposite to each other.

(3) Tighten bearing cap bolts in the following order to 10 N•m (85 in. lbs.). First #3, then #2, #1 and #4.

(4) Repeat step 3 increasing the torque to 20 N•m (180 in.lbs.).

(5) Install distributor drive adaptor assembly (Fig. 11).

CAMSHAFT OIL SEAL — ENGINE OUT OF VEHICLE

(1) Apply light coat of engine oil to the camshaft oil seal lip.

(2) Install the oil seal using camshaft oil seal installer tool MD998713 (Fig. 12).

CAMSHAFT END SEAL (PLUG) — ENGINE IN VEHICLE

(1) Remove air cleaner assembly from engine.

(2) Use a small punch and a hammer, carefully remove cam plug from cylinder head.

(3) Clean the area of the cylinder head where the new cam plug will be installed.

(4) Apply a light coating of Mopar Silicone Rubber Adhesive Sealant to the outer diameter of the **NEW** cam plug.

(5) Using a suitable installing tool and a hammer,

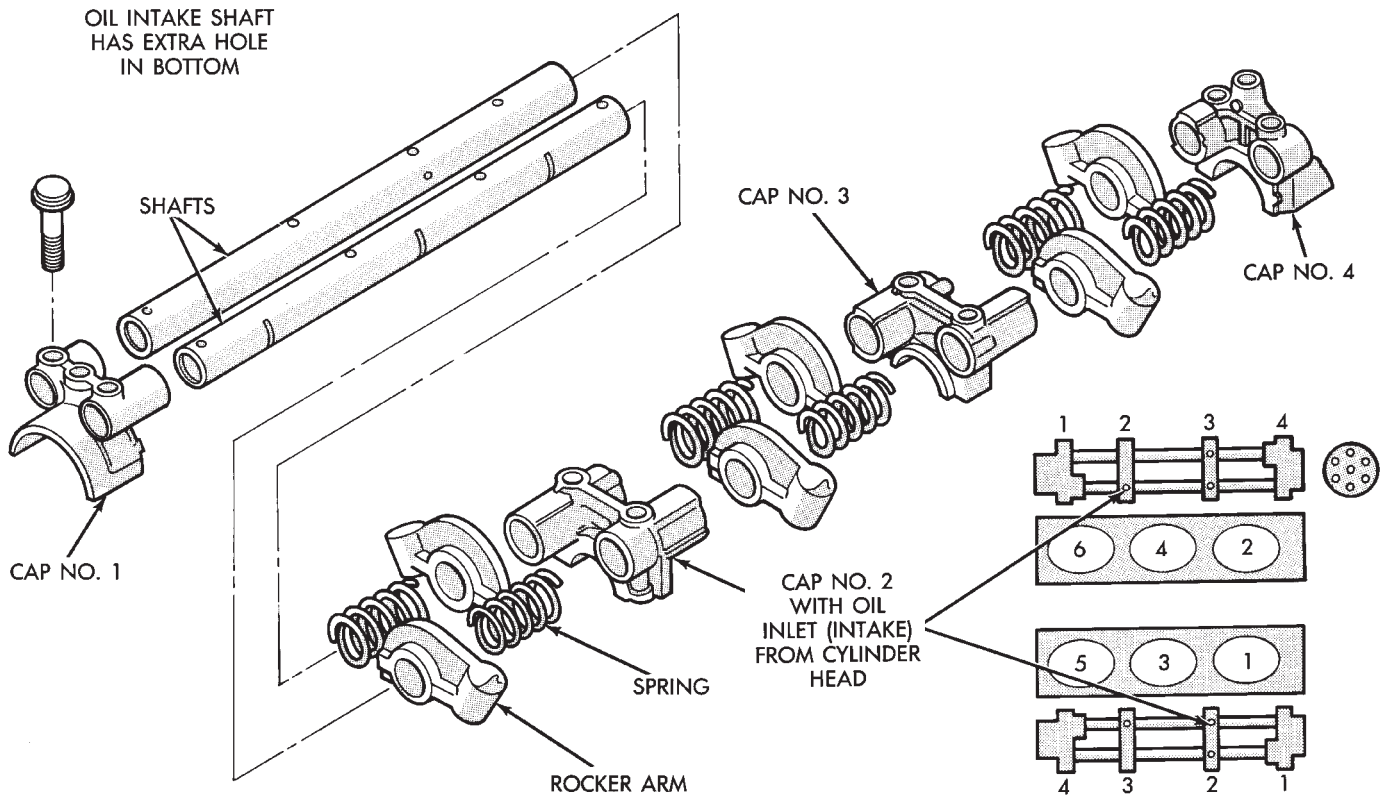

9209-70

Fig. 10 Assemble Rocker Arm and Shafts

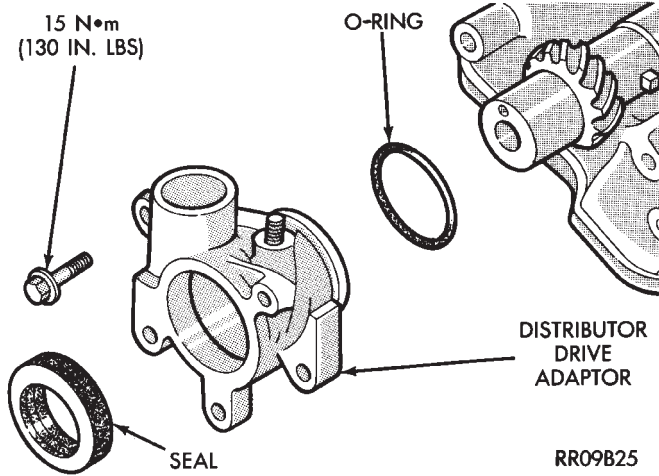

Fig. 11 Distributor Drive

install the new cam plug to a depth of 0.5mm (0.020 inch) below the surface of the cylinder head.

(6) Replace air cleaner assembly.

CAMSHAFT END SEAL (PLUG) — ENGINE OUT OF VEHICLE

Install end seal plug with Special Tool MD998306. (Fig. 13).

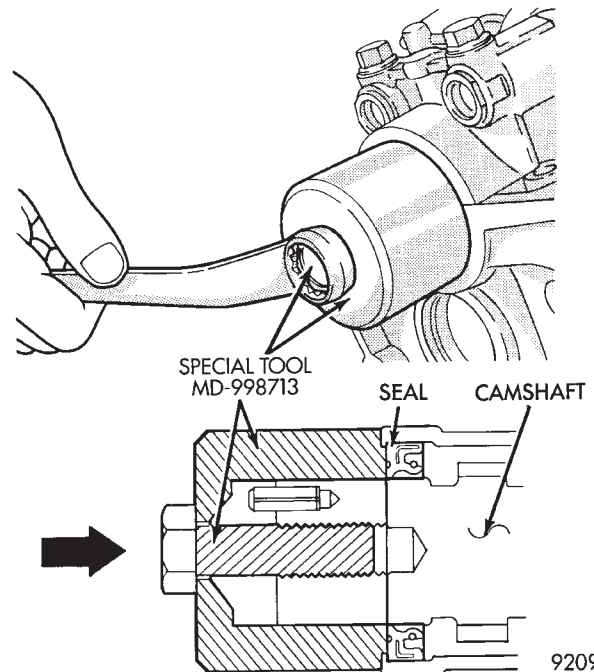

9209-3

Fig. 12 Install Camshaft Oil Seal
CYLINDER HEAD

REMOVAL

(1) See Timing System this group for disassembly and remove camshaft sprockets.

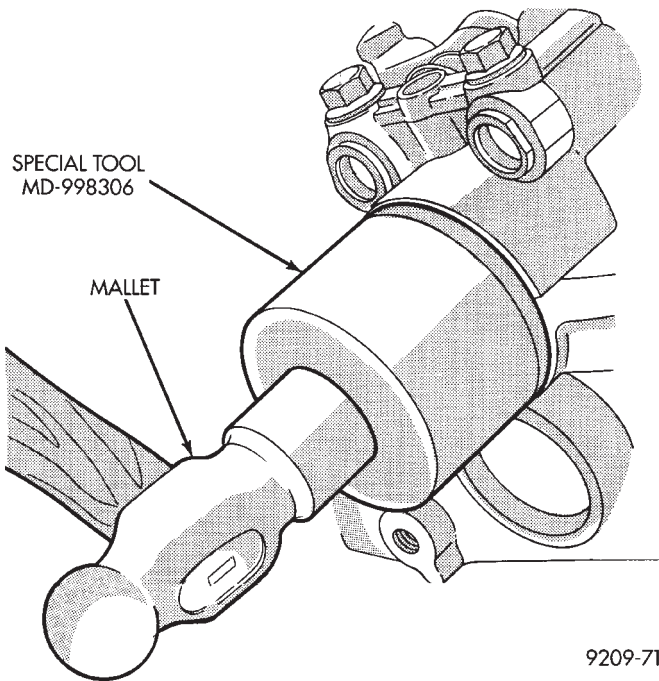

Fig. 13 Install Camshaft End Seal—Plug

- (2) See Camshaft Rocker Arms Removal.
- (3) Remove upper intake manifold assembly. Refer to Intake and Exhaust Manifolds, Group 11.
- (4) Remove distributor.
- (5) Remove exhaust manifolds and cross over Refer to Intake and Exhaust Manifolds, Group 11.

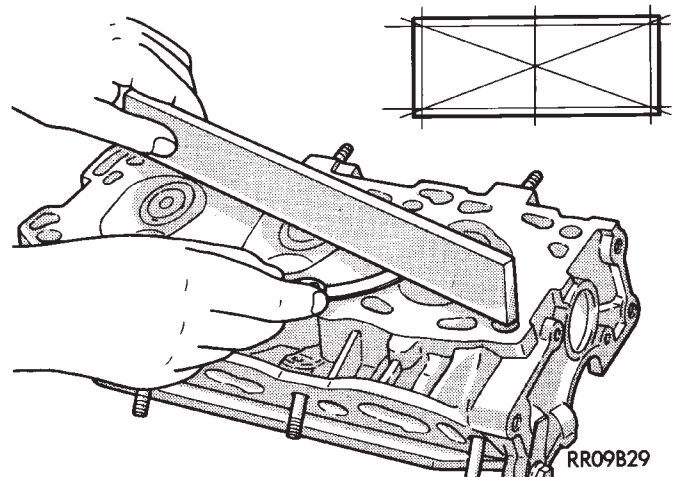

Fig. 15 Check Cylinder Head

- (2) Clean cylinder head and oil passages.
- (3) Check cylinder head for flatness (Fig. 15).
- (4) Cylinder head must be flat within;
 - Standard dimension = less than 0.05mm (.002 inch)
 - Service Limit = 0.2mm (.008 inch)
 - Grinding Limit = Maximum of 0.2 mm (.008 inch) is permitted.

CAUTION: This is a combined total dimension of stock removal from cylinder head if any and block top surface.

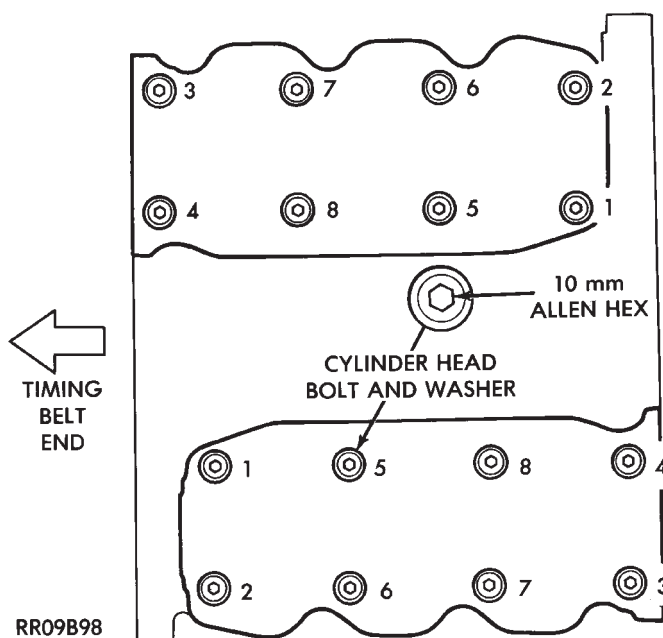

Fig. 14 Cylinder Head Bolt Removal Sequence

- (6) Remove cylinder head bolts in sequence shown in (Fig. 14) and remove cylinder head.

INSPECTION

- (1) Before cleaning, check for leaks, damage and cracks.

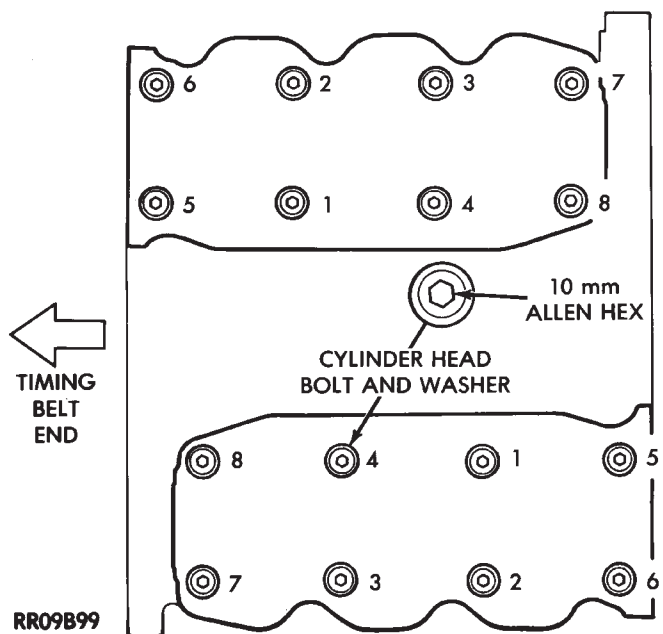

Fig. 16 Cylinder Head Bolt Tightening Sequence

INSTALLATION

- (1) Clean surfaces of head and block, install head gasket over locating dowels.
- (2) Install head on locating dowels.
- (3) Install 10mm Allen Hex head bolts with washers.

(4) Tighten bolts in the order shown in (Fig. 16). When tightening the cylinder head bolts, tighten gradually, working in two or three steps and finally tighten to specified torque of 108 N•m (80 ft. lbs.).

VALVE SERVICE

VALVE AND VALVE SPRINGS

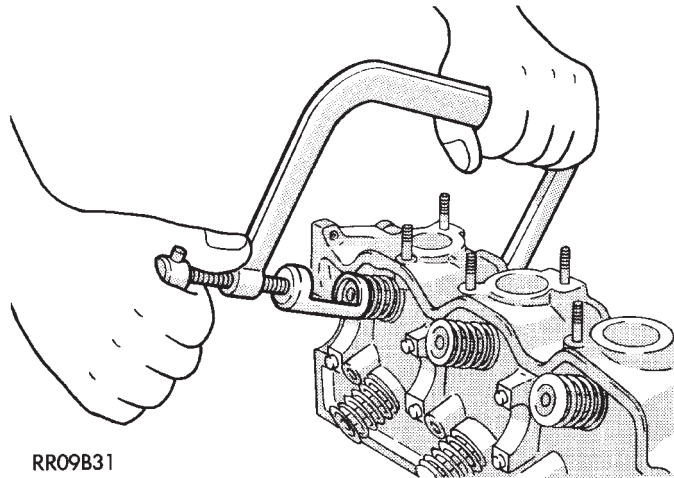

RR09B31

Fig. 17 Remove Valves

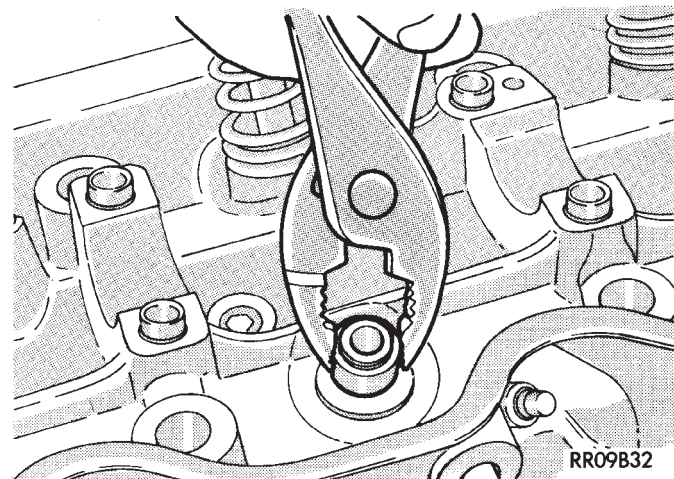

RR09B32

Fig. 18 Remove Valve Stem Seals

(1) With suitable valve spring compressor, remove spring retainer locks, retainer, valve spring, spring seat and valve (Fig. 17).

(2) Remove valve stem seals with suitable tool (Fig. 18). Do not reuse valve stem seals.

VALVES

(1) Check valve stem tip for pitting or depression at point A (Fig. 19).

(2) Check for wear and ridge wear at Point B.

(3) Check for even contact (at face center) with valve seat, Point C.

(4) Check margin. Replace valve if margin is out of specification (Fig. 20).

(5) Measure valve stem to guide clearance.

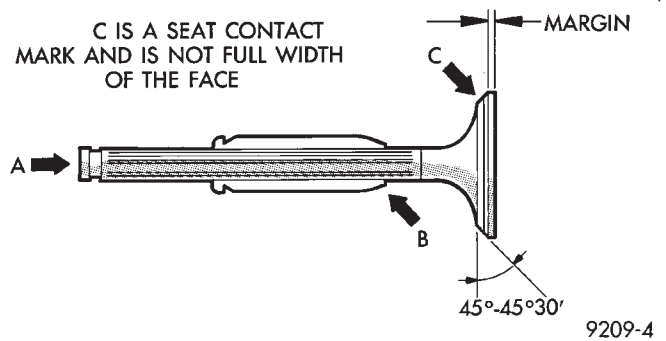

9209-4

Fig. 19 Valve Inspection

(6) Measure Valve spring free length and squareness (Fig. 21). Refer to (Fig. 20) for specifications.

| VALVE DIMENSIONS | | |
|--------------------------------|--|--|
| INTAKE VALVE (MINIMUM) | | |
| STEM DIAMETER: | 7.960 mm (.313 in.) | |
| FACE ANGLE: | 45° | |
| VALVE MARGIN: | .700 mm (.028 in.) | |
| LENGTH: | 103.0 mm (4.055 in.) | |
| EXHAUST VALVE (MINIMUM) | | |
| STEM DIAMETER: | 7.930 mm (.312 in.) | |
| FACE ANGLE: | 45° | |
| VALVE MARGIN: | 1.50 mm (.059 in.) | |
| LENGTH: | 102.70 mm (4.043 in.) | |
| VALVE GUIDE CLEARANCE | NEW | SERVICE LIMIT |
| INTAKE | 0.03 TO 0.06 mm (.001 TO .002 in.) | 0.10 mm (.004 in.) |
| EXHAUST | 0.05 TO 0.09 mm (.002 TO .0035 in.) | 0.15 mm (.006 in.) |
| VALVE SPRING SPECIFICATION | | |
| FREE LENGTH | NEW | 49.8 mm (1.960 in.) |
| | SERVICE LIMIT | 48.8 mm (1.921 in.) |
| SQUARENESS | NEW | 2° MAXIMUM |
| | SERVICE LIMIT | 4° MAXIMUM |
| SPRING TENSION | INSTALLED HEIGHT | 40.4 mm AT 33 KG (1.59 in. 73 LBS.) |

9109-60

Fig. 20 Valve Specification

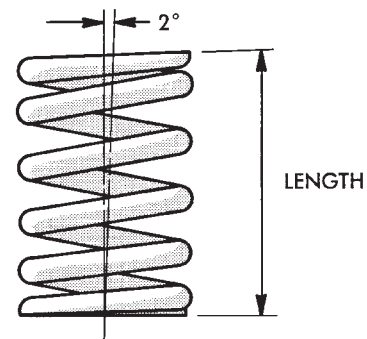

9209-5

Fig. 21 Valve Spring

VALVE SEAT INSPECTION

Inspect the valve seat with Prussian blue to determine where the valve contacts the seat. To do this,

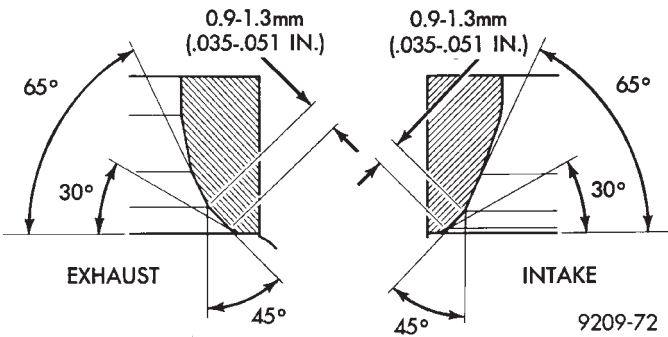

Fig. 22 Valve Seat Reconditioning

coat valve seat **LIGHTLY** with Prussian blue then set valve in place. Rotate the valve with light pressure. If the blue is transferred to the center of valve face, contact is satisfactory. If the blue is transferred to top edge of the valve face, lower valve seat with a 15 degrees stone. If the blue is transferred to the bottom edge of valve face raise valve seat with a 65 degree stone.

- (1) Install valve spring seat.
- (2) Using suitable tool install seal by tapping lightly until seal is in place. (Fig. 23).

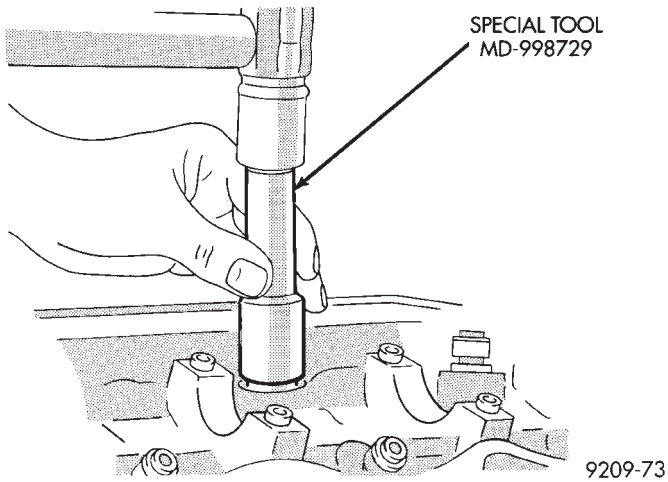

Fig. 23 Install Valve Stem Seals

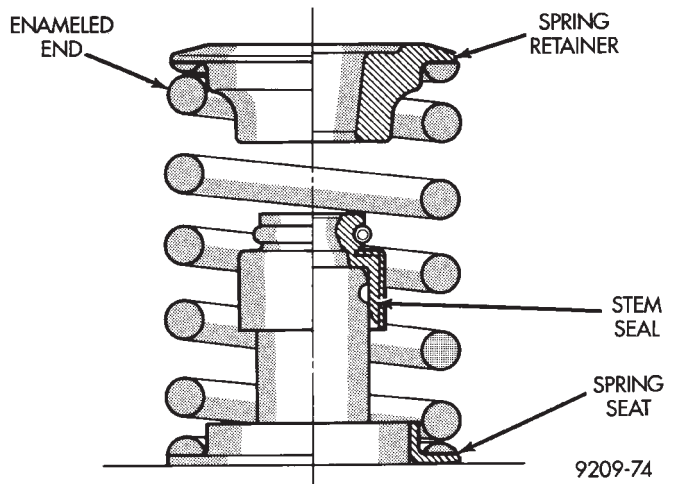
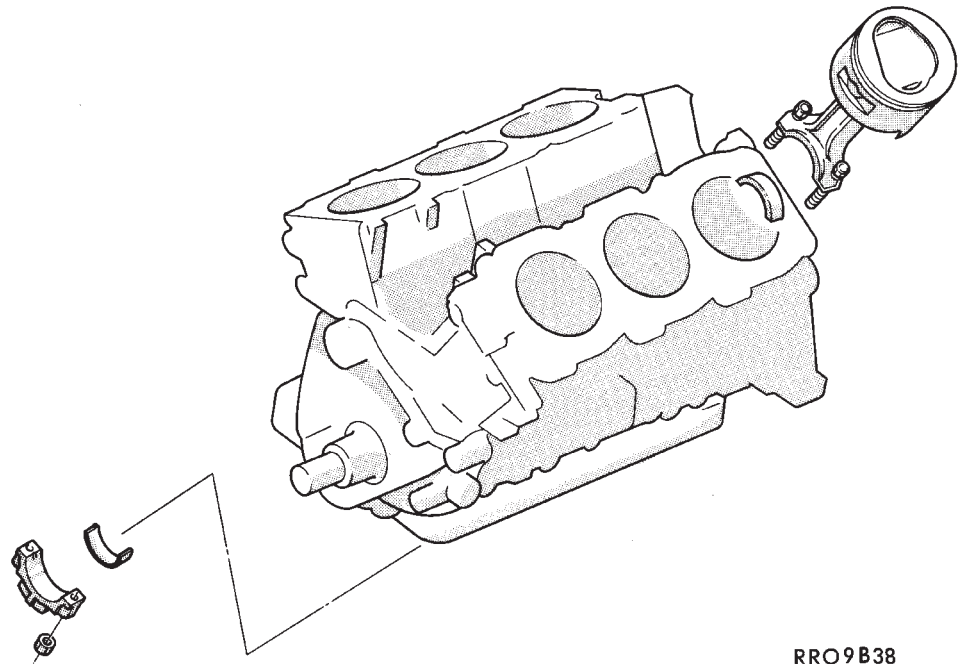
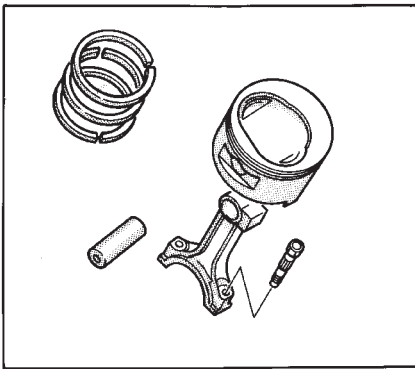

Fig. 24 Installed Valve Spring Position

- (3) Install valve spring with the enamelled ends facing the rocker arms (Fig. 24).

CAUTION: During reassembly, compressing the valve spring more than necessary to install valve spring retainer locks can cause the retainer to be forced against the stem seal and damaging it.

PISTON AND CONNECTING ROD ASSEMBLY SERVICE



RR09B38

Fig. 1 Pistons, Connecting Rods

(1) Mark Identify Pistons. **The pistons are not interchangeable from bank to bank** (Fig. 2).

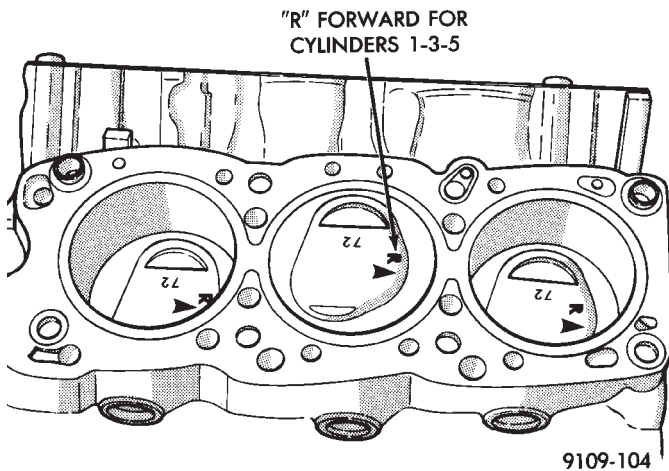

Fig. 2 Mark Pistons

9109-104

- (2) Mark connecting rod and cap with cylinder number (Fig. 3).
- (3) Remove piston rings (Fig. 4).

CYLINDER BORE INSPECTION

- (1) Measure the cylinder bore at three levels in directions A and B (Fig. 5). Top measurement should be 12mm (.50 inch) down and bottom measurement should be 10mm (.38 inch) up.
- (2) Standard bore dimension: 91.1mm (3.587 inch)
- (3) Maximum out-of-round or taper: 0.02mm (.0008 inch)

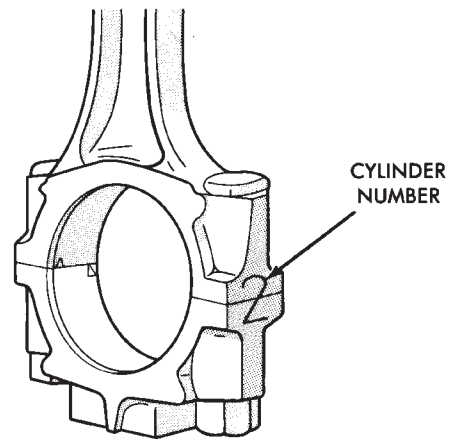

Fig. 3 Mark Matching Parts

RR09B40

FITTING PISTONS

Measure approximately 2mm (.080 inch) above the bottom of the piston skirt and across the thrust face. (Fig. 6), See Boring Cylinder in Cylinder Block.

FITTING PISTON RINGS

- (1) Wipe cylinder bore clean. Insert ring and push down with piston to ensure it is square in bore. The ring gap measurement must be made with the ring positioning at least 16mm (0.63 inch) from bottom of cylinder bore. Check gap with feeler gauge (Fig. 7). Refer to (Fig. 8) for specification.
- (2) Check piston ring to groove clearance; Refer to Piston Ring Specification Chart (Fig. 8).

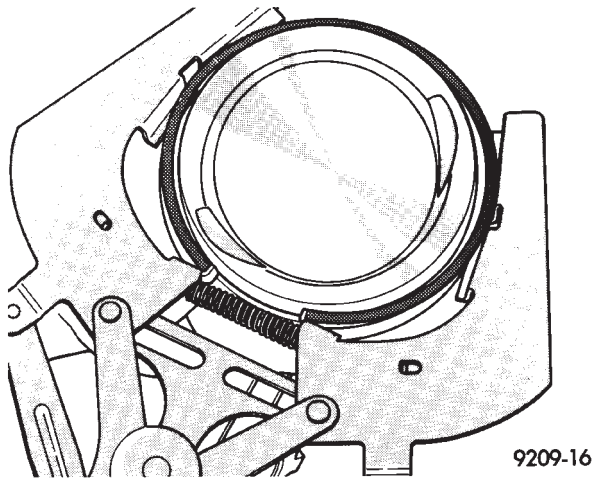

Fig. 4 Remove Piston Rings

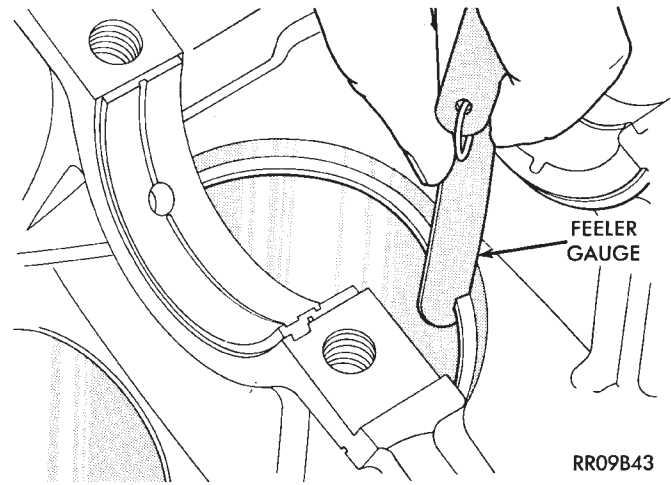

Fig. 7 Check Gap on Piston Rings

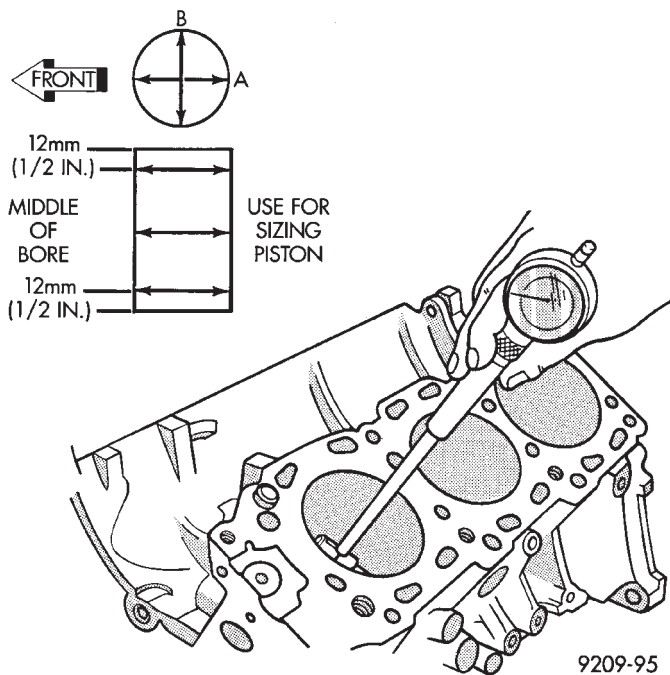

Fig. 5 Checking Cylinder Bore Size

| RING POSITION | RING GAP | WEAR LIMIT |
|-------------------|--|----------------------|
| UPPER RING | 0.30 TO 0.45 mm (.012 TO .018 in.) | 0.8 mm (.031 in.) |
| INTERMEDIATE RING | 0.25 TO 0.40 mm (.010 TO .016 in.) | 0.8 mm (.031 in.) |
| OIL CONTROL RING | 0.30 TO 0.90 mm (.012 TO .035 in.) | 1.0 mm (.039 in.) |
| RING POSITION | GROOVE CLEARANCE | MAXIMUM CLEARANCE |
| UPPER RING | 0.05 TO 0.09 mm (.002 TO .0035 in.) | .10 mm (.004 in.) |
| INTERMEDIATE RING | 0.02 TO 0.06 mm (.0007 TO .002 in.) | .10 mm (.004 in.) |

OIL CONTROL RING—THREE PIECE. OIL RING SIDE RAILS MUST BE FREE TO ROTATE AFTER ASSEMBLY.

9109-37

Fig. 8 Piston Ring Specification Chart

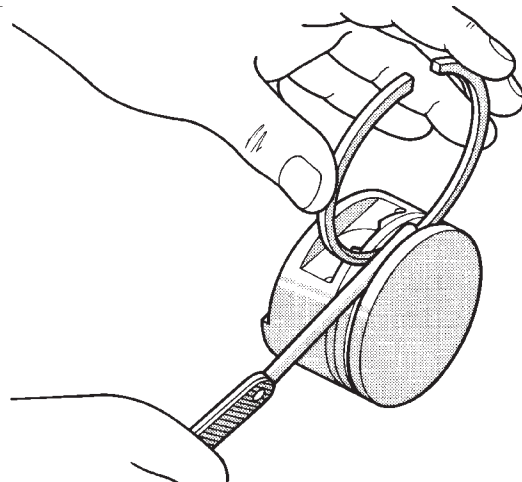

Fig. 9 Piston Ring Clearance

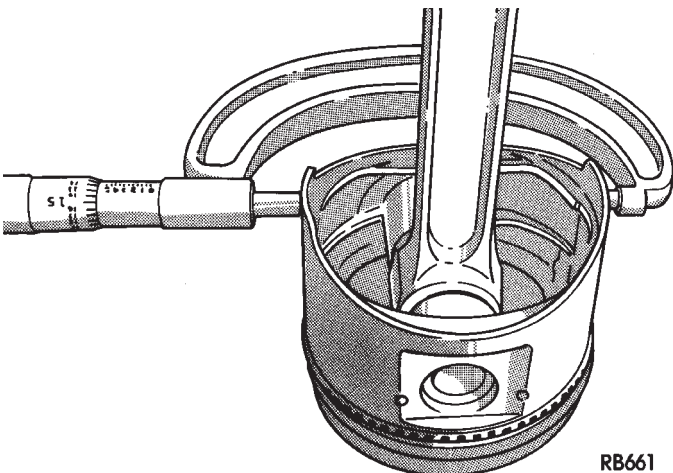

Fig. 6 Piston Clearance and Wear

PISTON RINGS—INSTALLATION

(1) The No. 1 and No. 2 piston rings have a different cross section. Install rings with manufacturers mark and size mark facing up, to the top of the piston (Fig. 10).

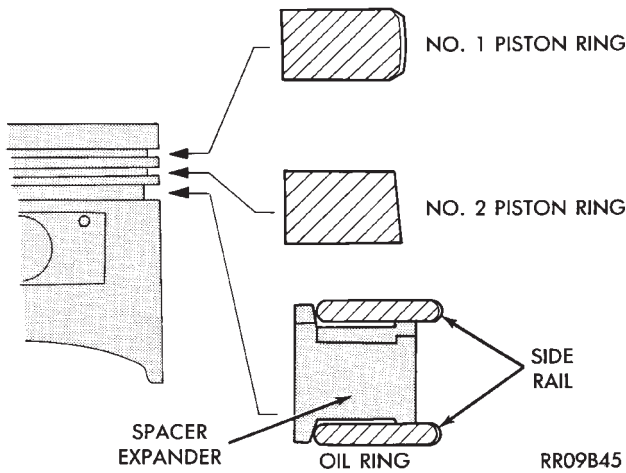

Fig. 10 Piston Ring Installation

CAUTION: Install piston rings in the following order:

- (a) Oil ring expander.
- (b) Upper oil ring side rail.
- (c) Lower oil ring side rail.
- (d) No. 2 Intermediate piston ring.
- (e) No. 1 Upper piston ring.

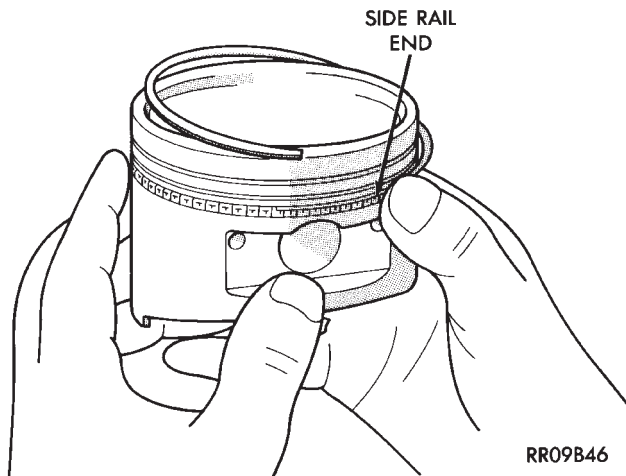

Fig. 11 Installing Side Rail

(2) Install the side rail by placing one end between the piston ring groove and the expander. Hold end firmly and press down the portion to be installed until side rail is in position. **Do Not use a piston ring expander** (Fig. 11).

(3) Install upper side rail first and then the lower side rail.

(4) Install No. 2 piston ring and then No. 1 piston ring (Fig. 12).

(5) Position piston ring end gaps as shown in (Fig. 13).

(6) Position oil ring expander gap at least 45° from the side rail gaps but **not** on the piston pin center or on the thrust direction.

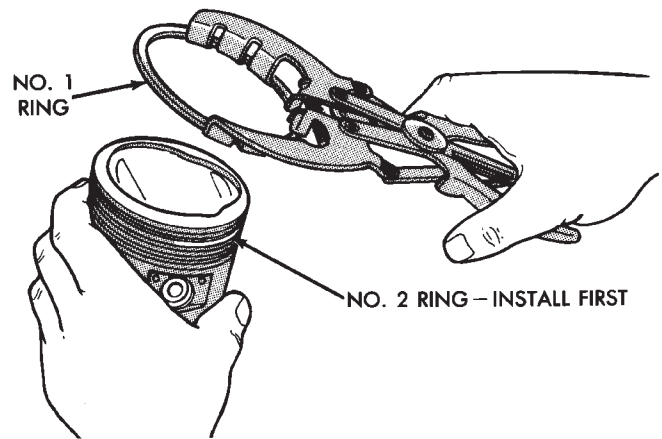

Fig. 12 Installing Upper and Intermediate Rings

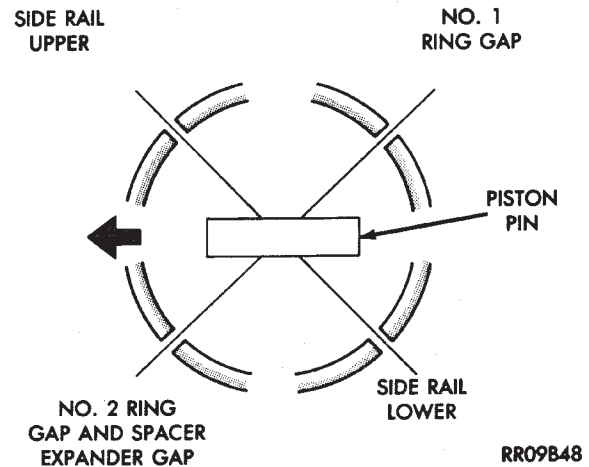

Fig. 13 Piston Ring End Gap Position

(7) Connecting rod front mark 72 must always face forward, toward timing belt end. (Fig. 14)

(8) Install the piston and connecting rod assembly into their respective bore from the cylinder block top.

CAUTION: Piston assemblies are not to be interchanged from bank to bank.

(9) Check alignment marks made during disassembly and that bearing position notches new or used are on the same side as shown in (Fig. 15).

CONNECTING ROD CLEARANCE

(1) Following procedures specified in the Standard Service Procedures Section for Measuring Main Bearing Clearance and Connecting Rod Bearing Clearance. (Fig. 16). Refer to (Fig. 18) for specifications.

(2) Tighten nuts to 52 N•m (38 ft. lbs.).

(3) Remove connecting rod cap and measure Plastigage (Fig. 16).

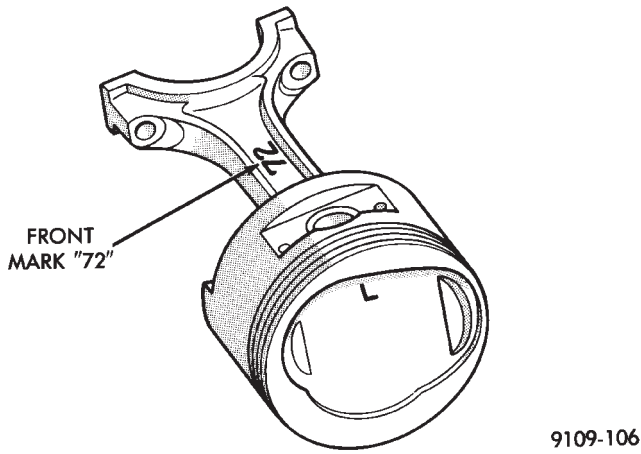

Fig. 14 Identify Piston/Rod Assembly for Cylinder Installation

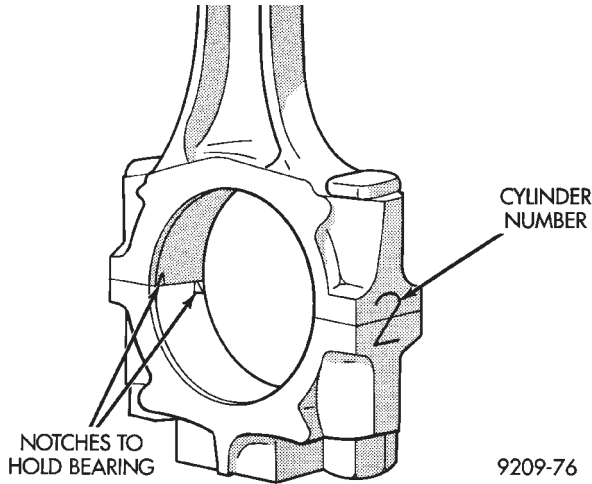

Fig. 15 Connecting Rod and Cap

CAUTION: Do not rotate crankshaft or the Plastigage may be smeared.

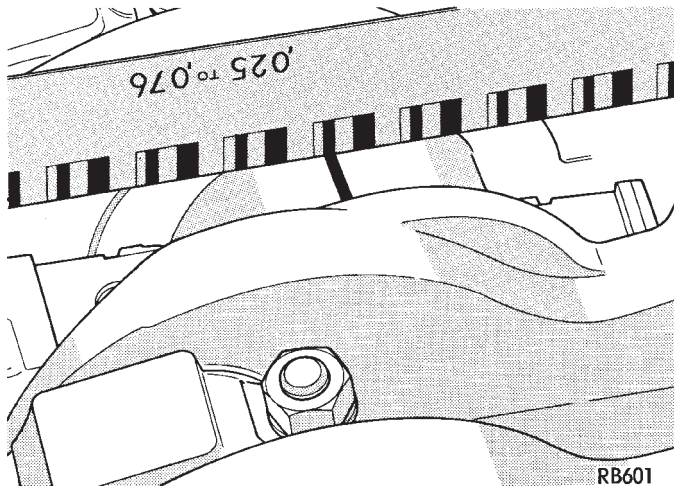

Fig. 16 Connecting Rod Checking Bearing Clearance

CONNECTING ROD SIDE CLEARANCE

Using a feeler gauge, check connecting rod side clearance (Fig. 17). Refer to (Fig. 18) for specification.

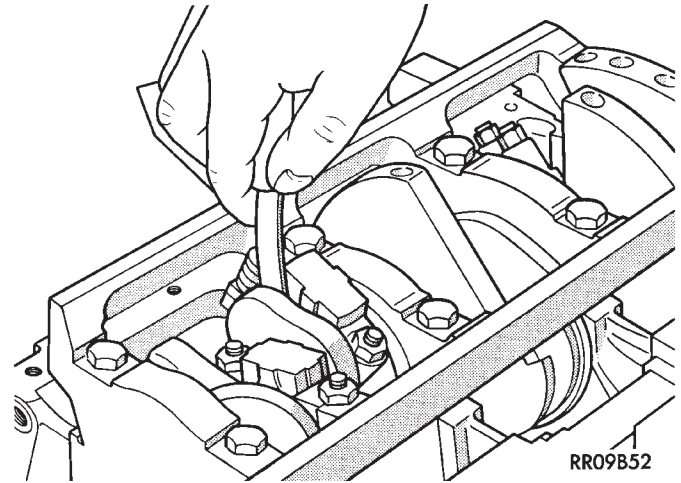

Fig. 17 Checking Connecting Rod Side Clearance

| CONNECTING ROD BEARING OIL CLEARANCE | |
|---|---|
| NEW PART: | .020 TO .067 mm (.0008 TO .0028 in.) |
| CONNECTING ROD SIDE CLEARANCE | |
| NEW PART: | 0.10 TO 0.25 mm (.004 TO .010 in.) |
| WEAR LIMIT: | 0.4 mm (.015 in.) |

9109-38

Fig. 18 Connecting Rod Clearance Specifications



CRANKSHAFT AND CYLINDER BLOCK, ASSEMBLY SERVICE

| TORQUE | |
|--------|-----------------------|
| ◇ | 10 N·m (88 IN. LBS.) |
| ◇ | 15 N·m (130 IN. LBS.) |
| ◇ | 83 N·m (61 FT. LBS.) |

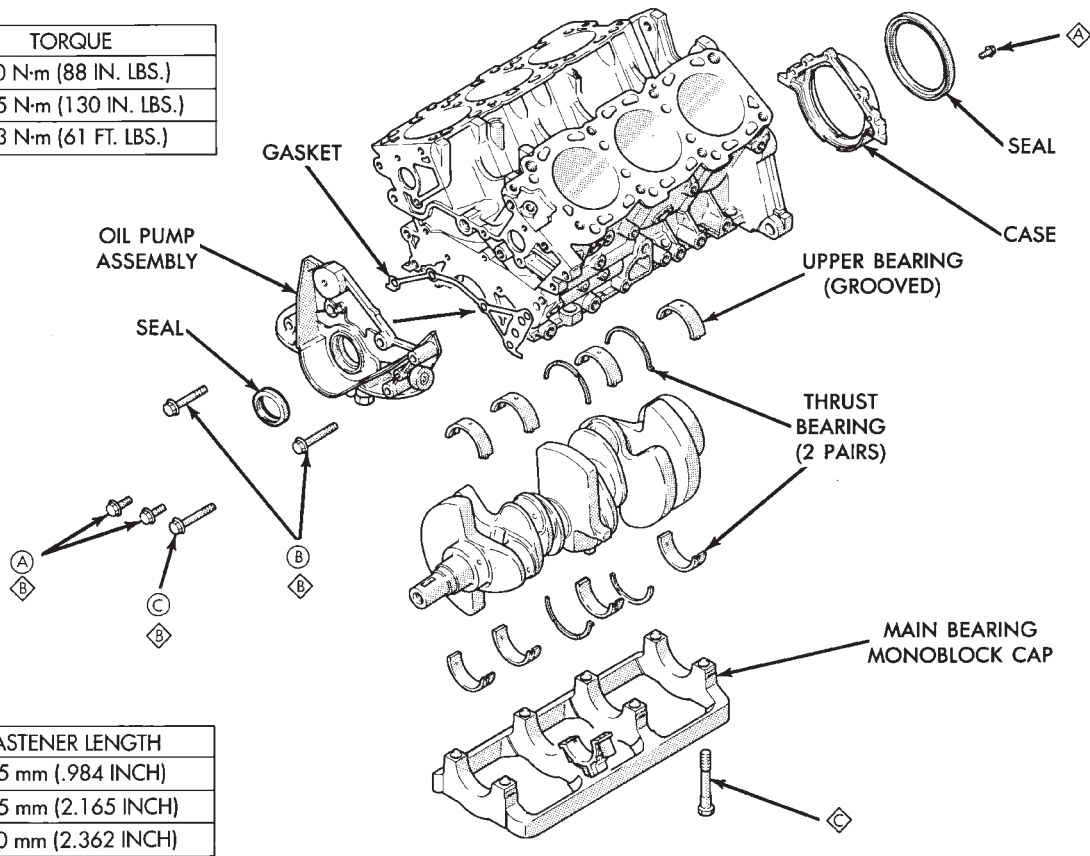

| FASTENER LENGTH | |
|-----------------|--------------------|
| (A) | 25 mm (.984 INCH) |
| (B) | 55 mm (2.165 INCH) |
| (C) | 60 mm (2.362 INCH) |

9209-77

Fig. 1 Crankshaft and Cylinder Block

CRANKSHAFT SERVICE

The crankshaft is supported in four main bearings. All upper bearing shells in the crankcase have oil grooves. All lower bearing shells in the monoblock main bearing cap are plain. Crankshaft end play is controlled by thrust washers on the number three main bearing journal.

CRANKSHAFT—REMOVAL

- (1) Remove front mounted oil pump assembly and gasket (Figs. 1 and 2).
- (2) Remove rear oil seal retainer and seal as assembly (Fig. 3).
- (3) Release monoblock main bearing cap bolts evenly. Remove lower bearing shells and identify for reassembly.
- (4) Lift out crankshaft and remove upper thrust washers from each side of number three main bearing in the crankcase (Fig. 1).

INSPECTION

Visually check the main and connecting rod bearing journals for wear, scuffs or scoring and replace if necessary.

L = LENGTH IN mm (INCH)
 TORQUE—ALL—15 N·m
 (130 IN. LBS.)

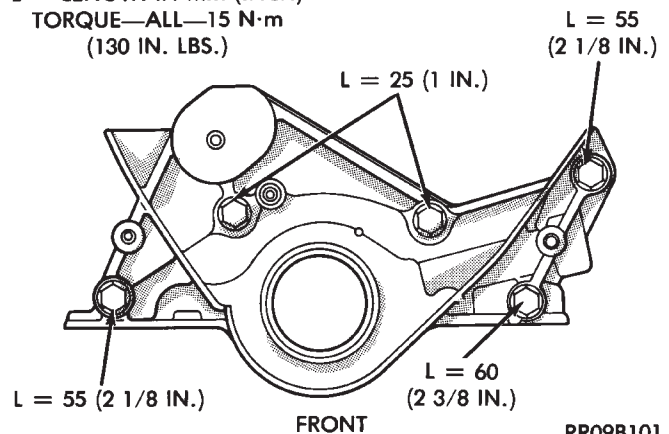

RR09B101

Fig. 2 Oil Pump Assembly

CRANKSHAFT OIL CLEARANCE

MECHANICAL MEASUREMENT

Measure the journal outside diameter and the main bearing inside diameter (Figs. 4 and 5). If the clearance exceeds the specifications limit (Fig. 6). Replace the main bearing(s) and if necessary replace the crankshaft.

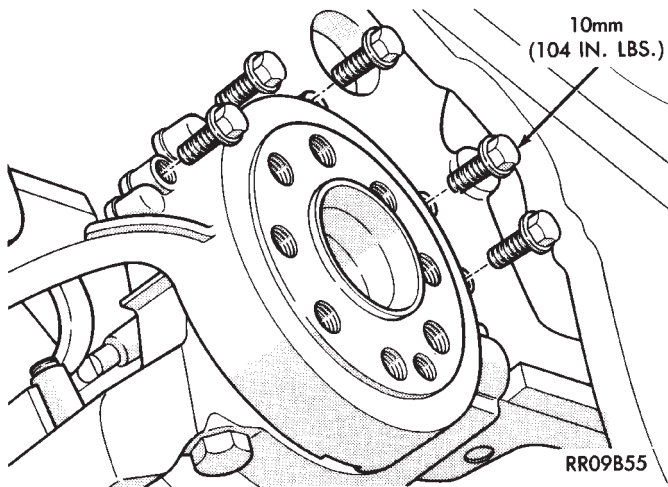

Fig. 3 Rear Seal Assembly

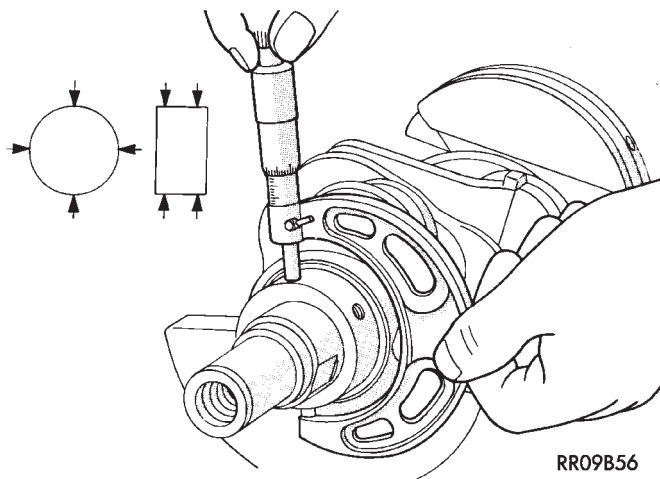

Fig. 4 Measure Crankshaft Journal O.D.

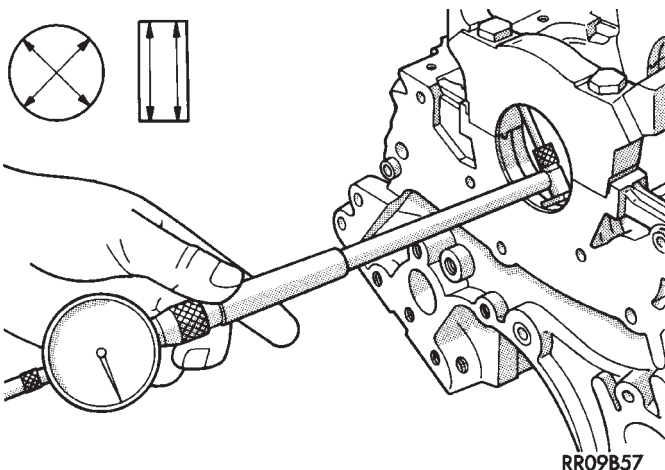

Fig. 5 Measure Main Bearing I.D.

PLASTIGAGE MEASUREMENT

- (1) Remove oil from journal and bearing shell.
- (2) Install crankshaft.
- (3) Cut plastigage to same length as width of the bearing and place it in parallel with the journal axis. (Fig. 7).

| CRANKSHAFT END-PLAY | |
|-----------------------------------|--------------------------------------|
| NEW PART: | .05 TO 0.25 mm (.002 TO .0010 in.) |
| WEAR LIMIT: | 0.30 mm (.012 in.) |
| MAIN BEARING OIL CLEARANCE | |
| NEW PART: | .020 TO .048 mm (.0008 TO .0018 in.) |
| WEAR LIMIT: | .10 mm (.0039 in.) |
| CRANKSHAFT JOURNAL SIZES | |
| CRANKSHAFT MAIN BEARING JOURNAL | |
| ALL | DIAMETER |
| STANDARD | 59.980 mm (2.361 in.) |
| CRANKSHAFT CONNECTING ROD JOURNAL | |
| ALL | DIAMETER |
| STANDARD | 50.00 mm (1.968 in.) |

9109-39

Fig. 6 Crankshaft Clearance Specification

- (4) Install the main bearing cap carefully and tighten the bolts to specified torque.

CAUTION: Do not rotate crankshaft or the plastigage will be smeared.

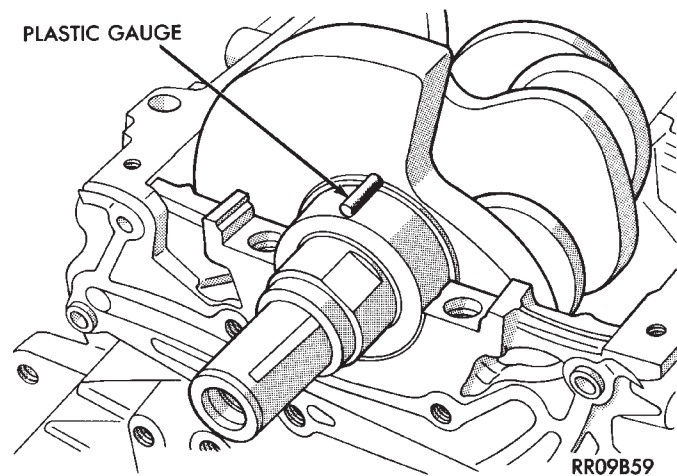

Fig. 7 Measure Oil Clearance with Plastigage

- (5) Carefully remove the bearing cap and measure the width of the plastigage at the widest part using the scale on the plastigage package (Fig. 8). Refer to specification (Fig. 6) for proper clearances. Also see Measuring Main and Connecting Rod Bearing Clearance in Standard Service Procedures.

CRANKSHAFT BEARINGS

INSTALLATION

- (1) Install upper main bearing shells making certain oil holes are in alignment, and bearing tabs seat in block tabs. All upper bearings have oil grooves (Fig. 9).

THRUST BEARINGS. Crankshaft thrust bearings (washers) are installed at journal #3 separately from the radial bearings. Thrust bearings shown in (Fig. 9) are different, one has end positioning tabs,

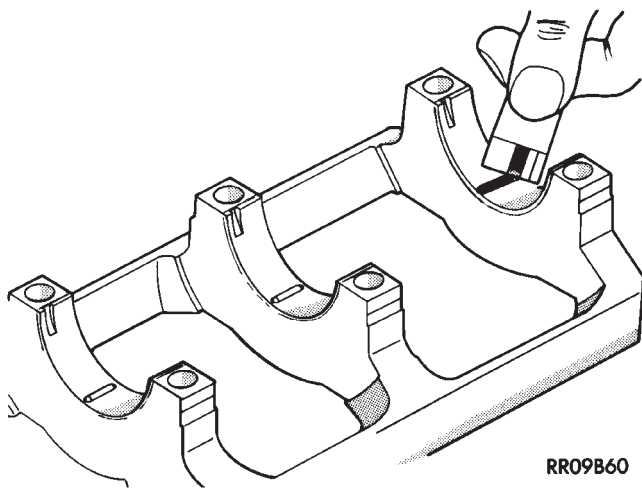

Fig. 8 Measuring Clearance

while the other is plain. One **pair** of each thrust washers are installed into the block and one **pair** into the main bearing cap (Fig. 9).

(2) Apply a thin film of grease to plain side of thrust washers and position them on each side of number three main bearing. Grooved surface towards crankshaft.

(3) Oil the bearings and journals and install crankshaft.

(4) Install lower main bearing shells without oil grooves in monoblock cap.

(5) Install one pair of thrust washers in cap. Refer to Thrust Bearings (Fig. 9).

(6) Carefully install bearing cap with arrows (Fig. 10) toward timing belt end.

(7) Oil the bearing cap bolt threads, install and tighten bolts progressively in sequence shown in (Fig. 9) to 80 N•m (60 ft. lbs.) torque.

CHECKING CRANKSHAFT END PLAY

(1) Mount a dial indicator to front of engine, locating probe on nose of crankshaft (Fig. 11).

(2) Move crankshaft all the way to the rear of its travel. (3) Zero the dial indicator.

(4) Move crankshaft all the way to the front and read the dial indicator. Refer to (Fig. 6) for specification.

CRANKSHAFT OIL SEALS SERVICE

REAR CRANKSHAFT SEAL RETAINER

(1) Install rear crankshaft oil seal in housing with Special Tool MD998718 (Fig. 12).

(2) Apply (Mopar Silicone Rubber Adhesive Sealant or equivalent) to oil seal housing (Fig. 13) per procedure detailed in form-in-place gasket section in Standard Service Procedures.

(3) Apply light coating of engine oil to the entire circumference of oil seal lip.

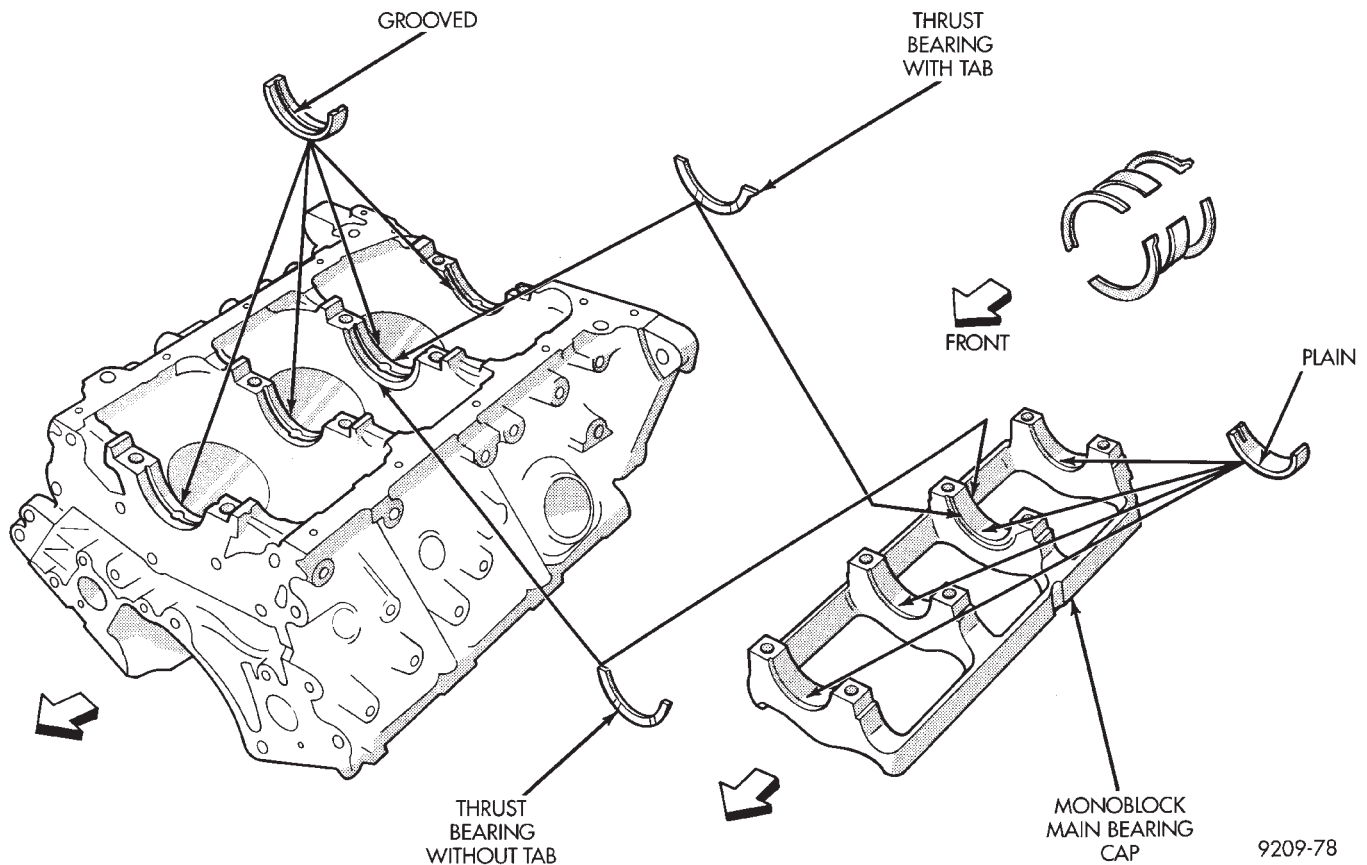

Fig. 9 Install Main Bearings

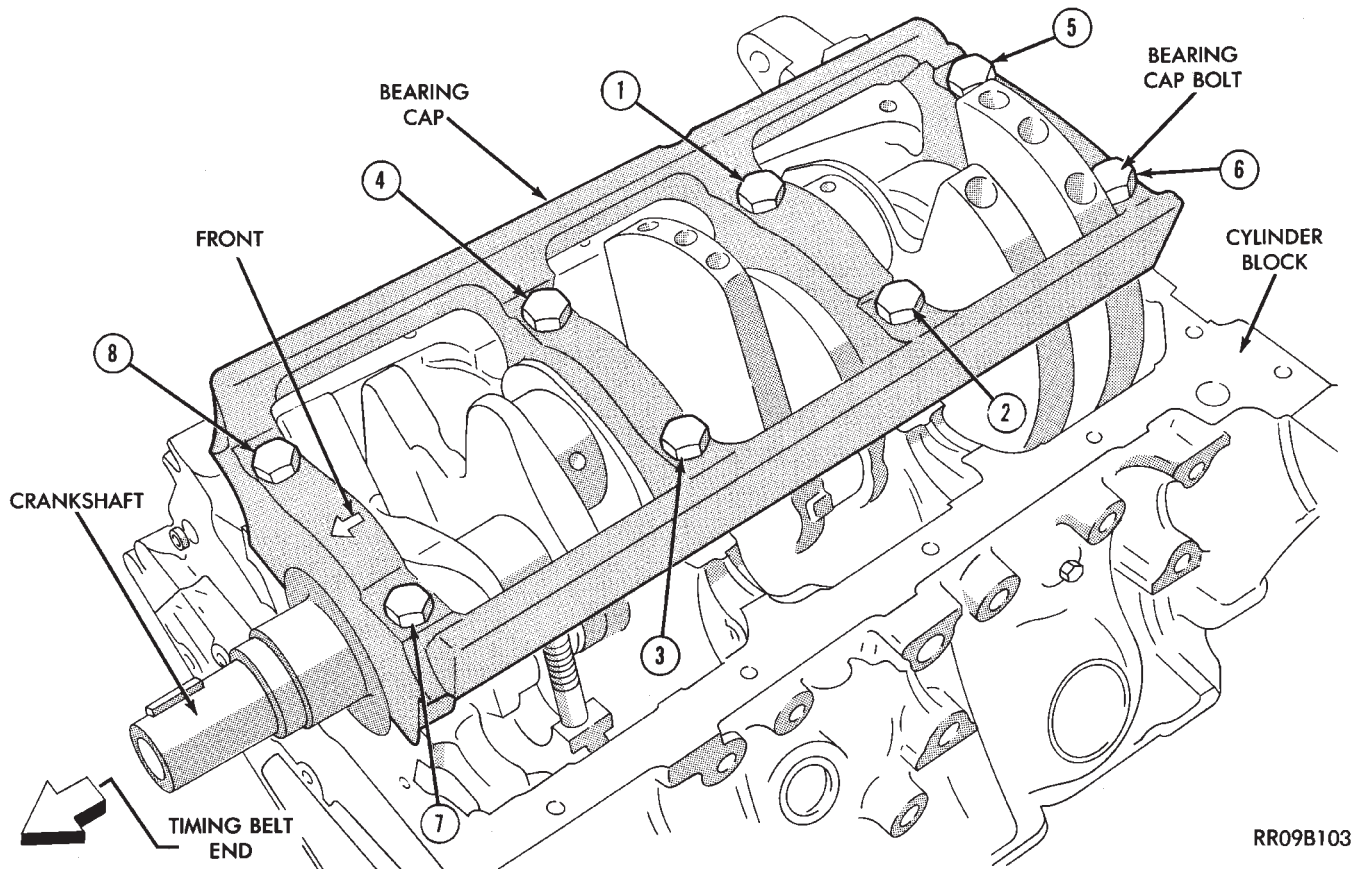

Fig. 10 Crankshaft Main Bearing Cap

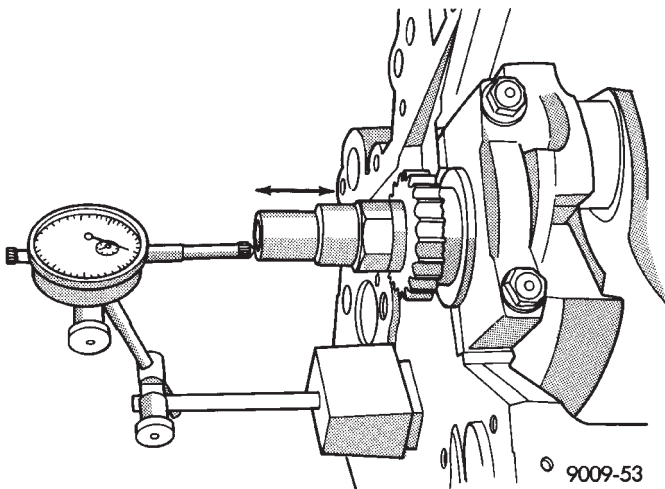

Fig. 11 Checking Crankshaft End Play

(4) Install seal assembly on cylinder block and tighten bolts to 12 N•m (104 in. lbs.).

FRONT CRANKSHAFT OIL PUMP AND OIL SEAL

(1) Install oil pump gasket and oil pump case (Figs. 1 and 14).

CAUTION: Install bolts, depending on length in locations shown in (Fig. 14).

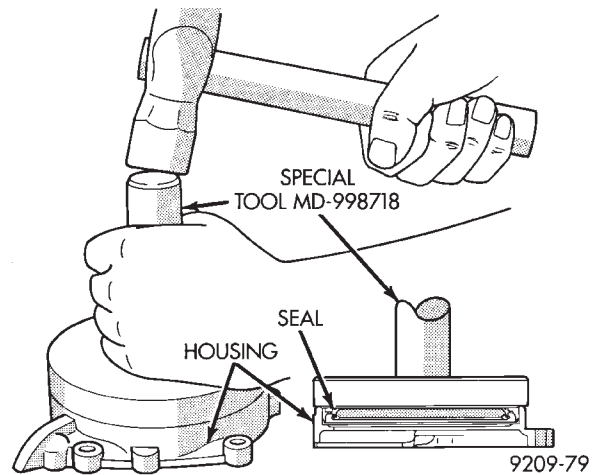

Fig. 12 Install Crankshaft Rear Oil Seal

(2) Using front crankshaft oil seal installer Special Tool MB998306 install oil seal in oil pump (Fig. 15).

CYLINDER BLOCK

Inspect cylinder block for scratches, cracks and rust or corrosion, and repair or replace as required.

(1) Clean cylinder block and check top surface for distortion with a straight edge and thickness gauge (Fig. 16).

- (2) Top surface must be flat within:
 - Standard Value: 0.05 mm (.002 inch)

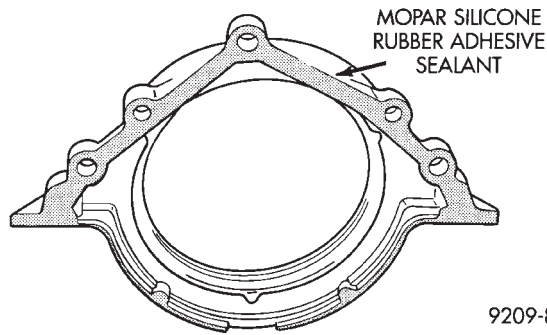

Fig. 13 Apply Sealant to Oil Seal Housing

L = LENGTH IN mm (INCH)
 TORQUE—ALL—15 N·m
 (130 IN. LBS.)

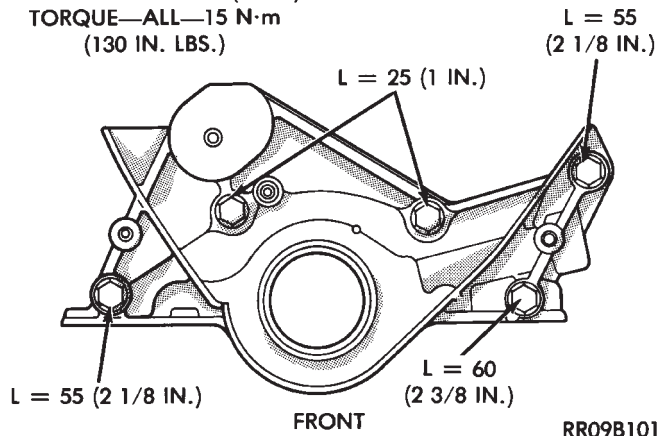

Fig. 14 Oil Pump

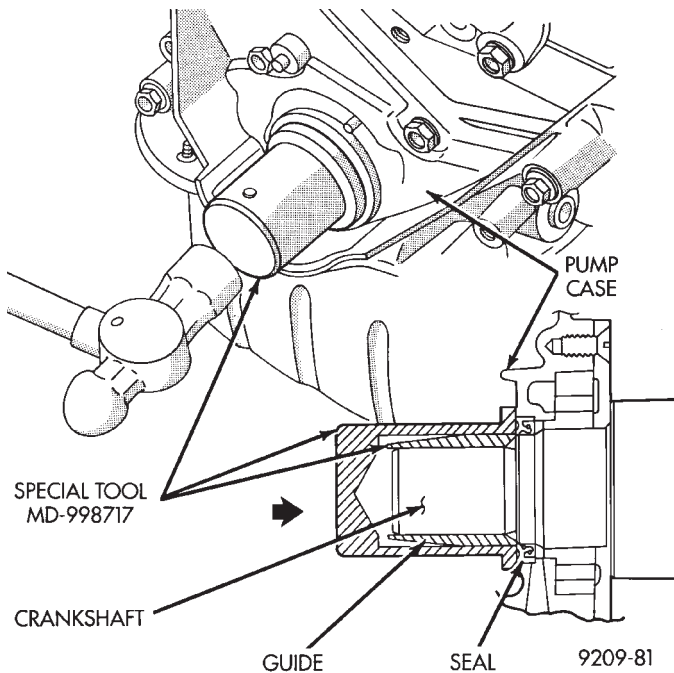

Fig. 15 Crankshaft Front Oil Seal

- Service Limit 0.1 mm (.003 inch)

CAUTION: Maximum of 0.2mm (.008 inch) is permitted. This is a combined total dimension of stock removal from cylinder head (if any) and block top surface.

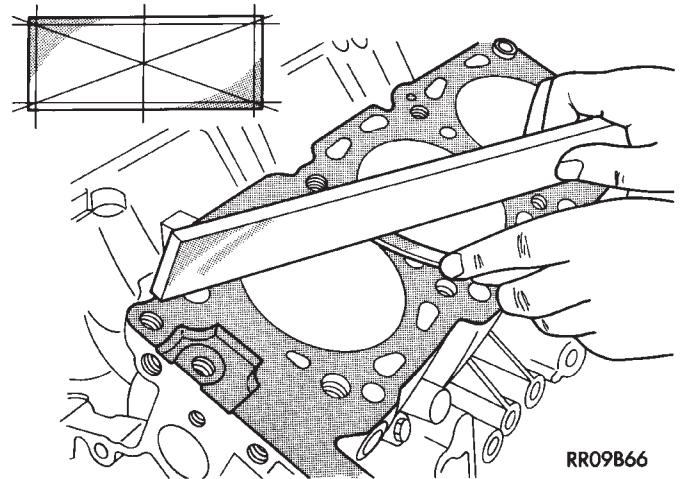

Fig. 16 Distortion Check

BORING CYLINDER

Examine cylinder walls for scuffs, scoring and measure cylinder bore for out-of-round or taper. If defective, bore cylinder to oversize. Measure at points shown in (Fig. 17).

Four oversize pistons are available (0.25mm (.010 inch) 0.50mm (.020 inch) 0.75mm (.030 inch) and 1.0mm (.039 inch). Determine oversize piston on basis of largest cylinder bore.

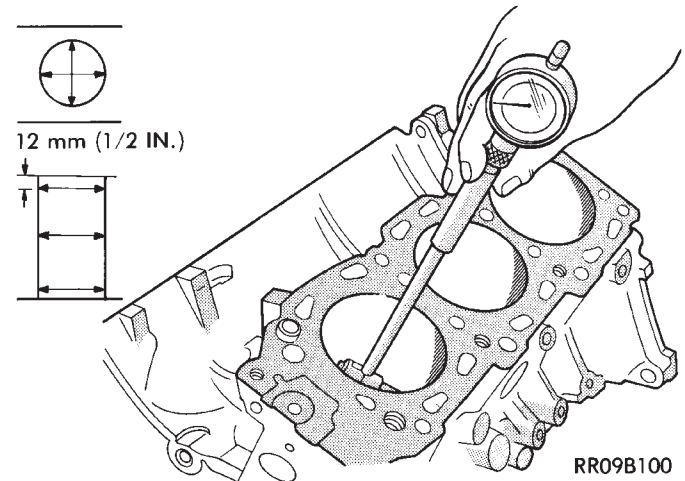

Fig. 17 Measure Cylinder Bore

(1) Bore to specified clearance between the piston O.D. and cylinder. The measuring point of the piston O.D. is shown in (Fig. 18).

(2) Based on measured piston O.D., calculate boring finish dimension. Boring finish dimension equals piston O.D. plus 0.03 to 0.05 mm (.0012 to .002 inch) (clearance between piston O.D. and cylinder) minus 0.02 mm which is the boring margin.

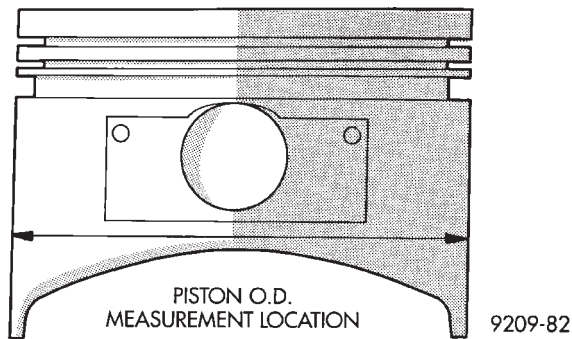

Fig. 18 Measure Piston

(3) Bore all cylinders to calculated boring finish dimension. Then bore the final finish dimension (piston O.D. plus cylinder clearance).

(4) Check clearance between piston and cylinder, clearance should be 0.03 to 0.05 mm (.0012 to .002 inch).

ENGINE LUBRICATION SYSTEM

CYLINDER WALLS
SPLASH LUBRICATED
FROM DIRECTED HOLES
IN CONNECTING RODS

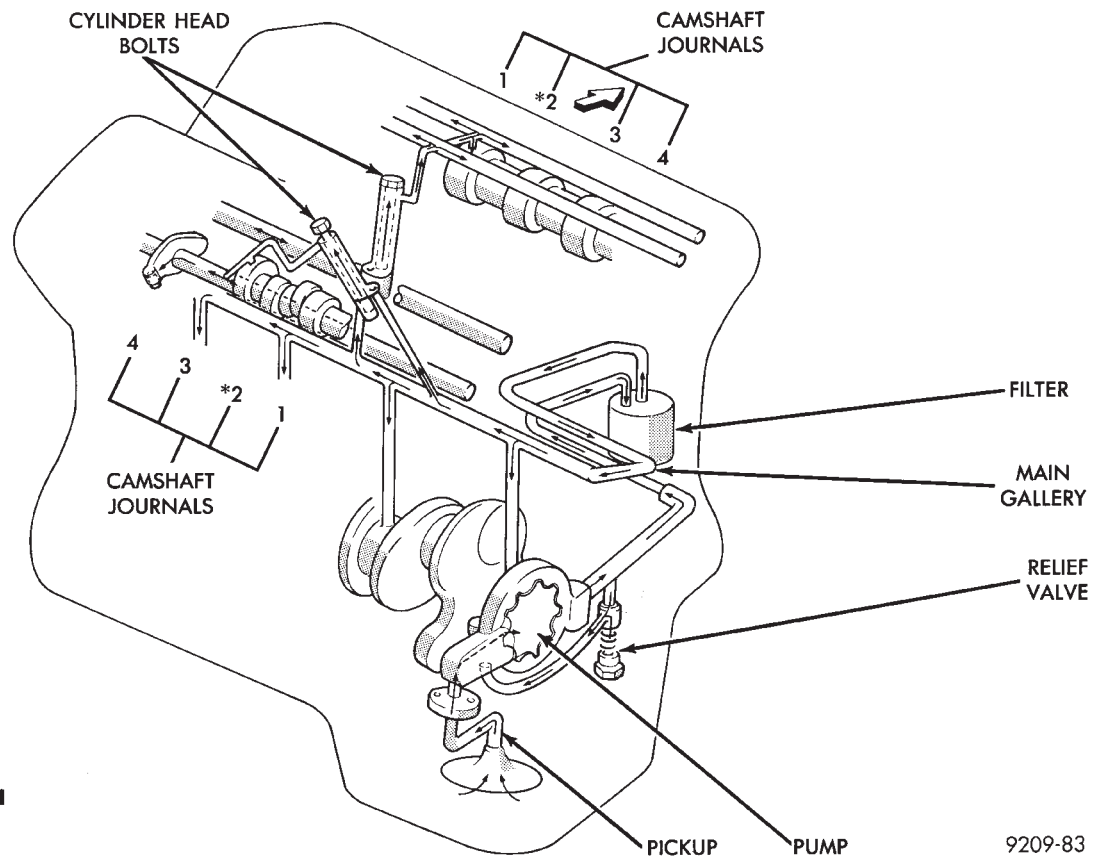

* NO. 2 CAMSHAFT
CAP (FRONT AND REAR)
RECEIVES OIL FROM
CYLINDER HEAD TO
SUPPLY ROCKERS, LASH
ADJUSTERS, CAMSHAFT
JOURNALS

Fig. 1 Engine Oiling

The lubrication system is a full flow filtration pressure feed type. Oil, stored in the oil pan, is taken in and discharged by an internal gear type oil pump directly coupled to the crankshaft and its pressure is regulated by a relief valve. The oil is fed through an oil filter and to the crankshaft journals from the oil gallery in the cylinder block. This gallery also feeds oil under pressure to the cylinder heads. It then

flows from a camshaft bearing cap one each cylinder head through passages in the rocker shafts and is fed to the rocker arm pivots, auto lash adjusters, and camshaft journals (Fig. 1).

9209-83



OIL PAN

The oil pan is made of sheet metal and is provided with a baffle-plate to prevent fluctuations in the oil level while the vehicle is running (Fig. 2).

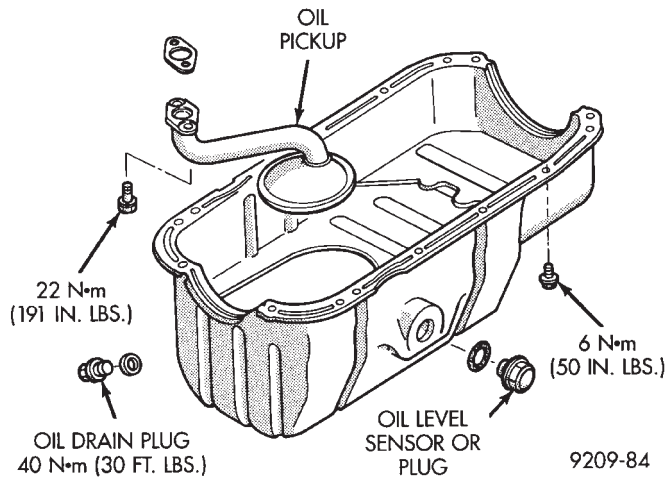

Fig. 2 Oil Pan

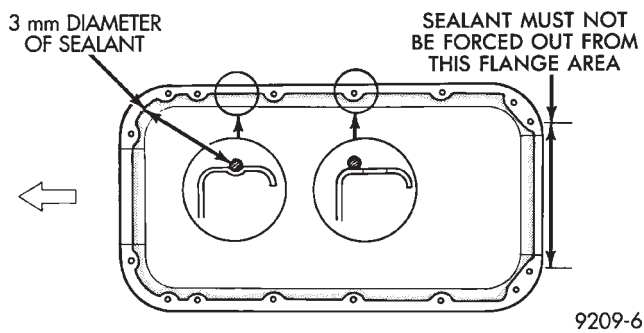

Fig. 3 Oil Pan Sealing

OIL PAN SEALING AND INSTALLATION

Oil pan to crankcase sealing is provided with Mopar Silicone Rubber Adhesive Sealant or equivalent gasket material. See Form-In-Place Gaskets in Standard Service Procedures.

- (1) Apply sealant as shown in (Fig. 3).
- (2) Install pan and tighten screws to 6 N·m (50 in. lbs.) in sequence shown in (Fig. 4).

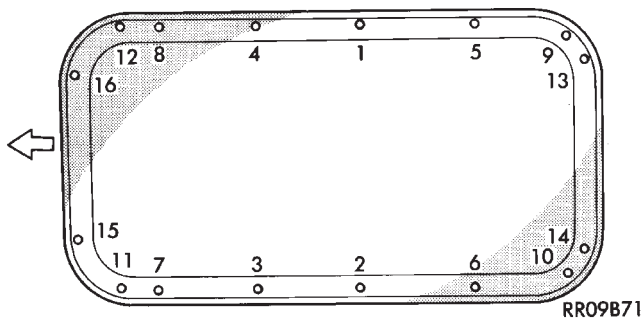

Fig. 4 Oil Pan Screw Tightening Sequence

OIL PUMP SERVICE

The oil pump assembly is mounted on the timing belt end of the cylinder block with the inner pump rotor indexed and installed on the crankshaft nose. (Fig. 5).

The oil pump case also retains the crankshaft front oil seal and provides oil pan front end closure.

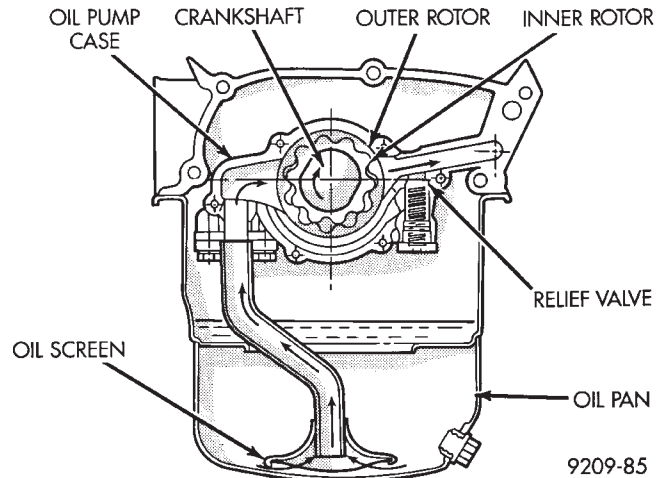

Fig. 5 Oil Pump-Installed

REMOVAL

Remove accessory drive system. Refer to Accessory Drive Service in this group.

Remove 5 bolts that attach oil pump to block (Fig. 6).

L = LENGTH IN mm (INCH)
TORQUE—ALL—15 N·m
(130 IN. LBS.)

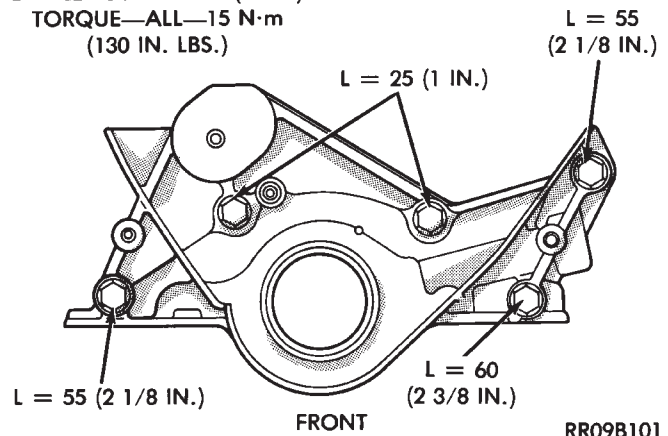

Fig. 6 Oil Pump Assembly

INSPECTION OIL PUMP

- (1) Check oil pump case for damage and remove rear cover.
- (2) Remove pump rotors and inspect case for excessive wear.
- (3) Measure clearance between case and inner rotor (Fig. 8).
- (4) Insert the rotor into the oil pump case (Figs. 9 and 10) and measure clearance with a feeler gauge as indicated.
- (5) Replace if out of limits.

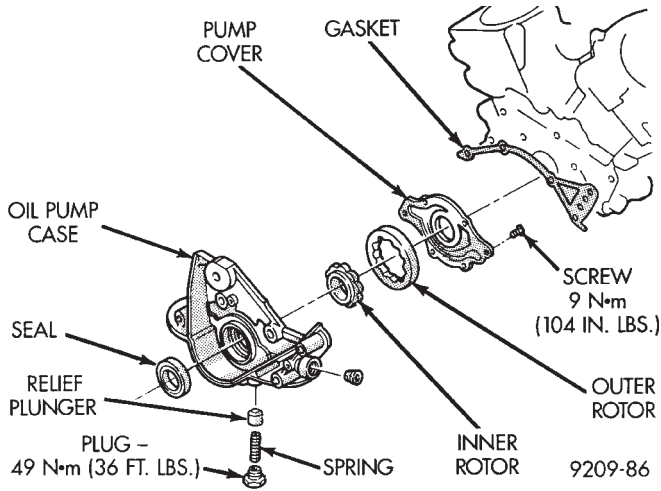
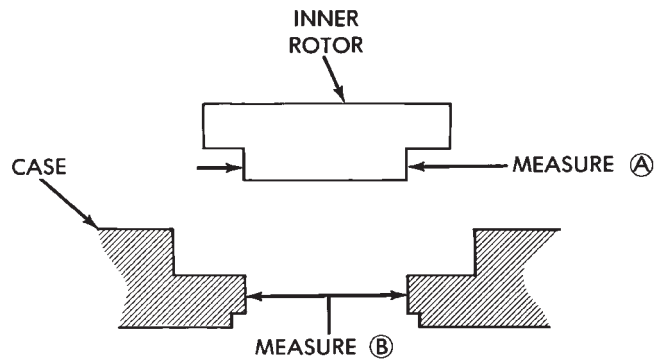

Fig. 7 Oil Pump Components



SUBTRACT MEASUREMENT A FROM MEASUREMENT B, IF OVER 0.006 IN., REPLACE OIL PUMP ASSEMBLY.

9209-114

Fig. 8 Inner Rotor to Case

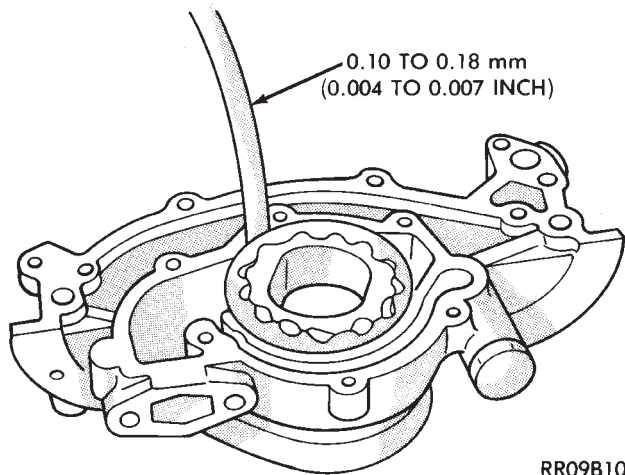

RR09B108

Fig. 9 Checking Clearance-Between Outer Rotor and Case

OIL RELIEF PLUNGER

- (1) Check that the oil relief plunger slides smoothly.
- (2) Check for broken relief spring.

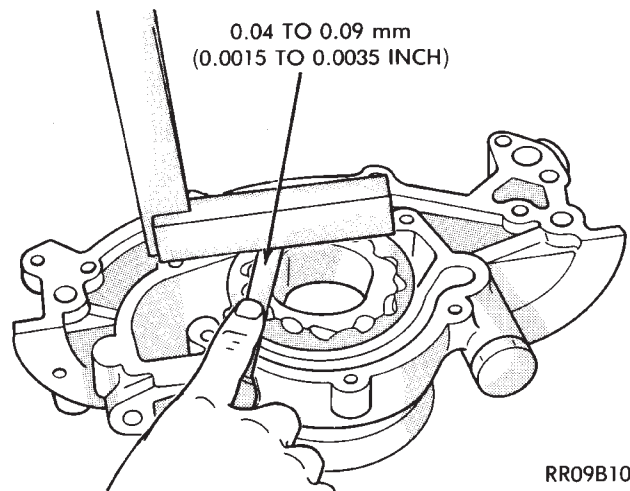

RR09B109

Fig. 10 Checking Rotor End Clearance

INSTALLATION

- (1) Clean block and pump surfaces.
- (2) Install new gasket (Fig. 7) make sure correct length bolts are used (Fig. 6).
- (3) Torque bolts to 13 N·m (120 in. lbs.).

CHECKING ENGINE OIL PRESSURE

Check oil pressure using gauge at oil pressure switch location. Oil pressure should be 41 kPa (6 psi.) at idle or 241 to 517 kPa (35 to 75 psi.) at 3000 RPM.

- (1) Remove pressure sending unit and install oil pressure gauge. (Fig. 11)

CAUTION: If oil pressure is 0 at idle, Do Not Run engine at 3000 RPM.

- (2) Warm engine at high idle until thermostat opens.

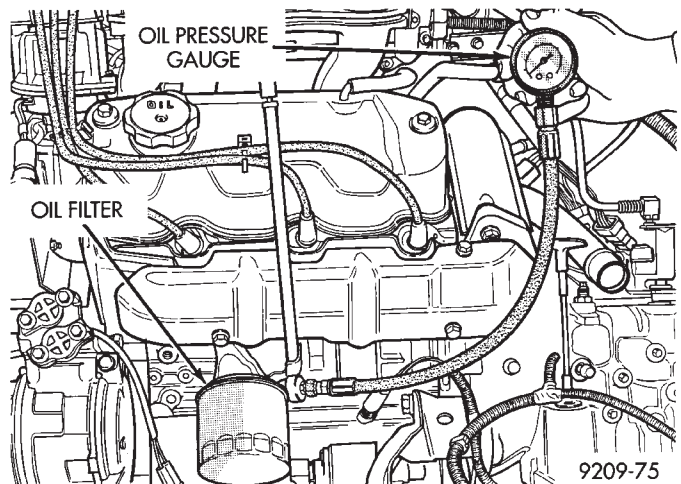

9209-75

Fig. 11 Checking Oil Pump Pressure

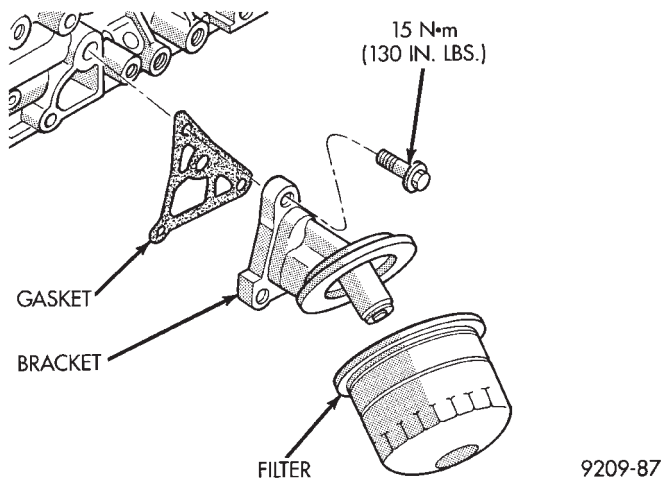

Fig. 12 Oil Filter and Bracket

OIL FILTER AND BRACKET

BRACKET

INSPECTION

(1) Check the oil filter mounting surface. The surface must be smooth, flat and free of debris or old pieces of rubber (Fig. 12).

(2) Check bracket for cracks and oil leaks.

OIL FILTER

(1) Turn counter clockwise to remove.

(2) To install, lubricate new filter gasket. Screw filter on until gasket contacts base. Tighten 1 turn.



ENGINE SPECIFICATIONS

| Standard | |
|---------------------------------|---|
| Type | 60° V SOHC (Per Bank) |
| Number of Cylinders | 6 |
| Bore | 91.1 mm (3.587 inches) |
| Stroke | 76 mm (2.992 inches) |
| Compression Ratio | 8.85:1 |
| Displacement | 3.0 Liters (181 Cubic inches) |
| Firing Order | 1-2-3-4-5-6 |
| Basic Ignition Timing | Refer to Emission Control Information on Label in Vehicle |
| Valve Timing | |
| Intake —Open | 19° BTDC |
| —Close | 59° ABDC |
| Exhaust —Open | 59° BBDC |
| —Close | 19° ATDC |

| Description | Standard Dimension | Service Limit |
|--|---|-------------------------|
| Compression Pressure | 178 psi @ 250 RPM | — |
| Maximum Variation Between Cylinders | 1.0 Kg/cm ² (14 PSI) | 25% |
| Valve Clearance—Hot Engine | Hydraulic Lash Adjusters | — |
| Cylinder Head | | |
| Flatness of Gasket Surface | 0.05 mm (0.002 inch) | — |
| Grinding Limit of Gasket Surface | — | 0.2 mm (0.008 inch) |
| Manifold—Flatness of Installing Surface | | |
| Intake | 0.10 mm (0.004 inch) | 0.2 mm (0.0008 inch) |
| Exhaust | 0.15 mm (0.006 inch) | 0.3 mm (0.001 inch) |
| Valves | | |
| Thickness of Valve Head (Margin) | | |
| Intake | 1.2 mm (0.047 inch) | 0.7 mm (0.027 inch) |
| Exhaust | 2.0 mm (0.079 inch) | 1.5 mm (0.059 inch) |
| Valve Stem to Guide Clearance | | |
| Intake | 0.03 to 0.06 mm (0.001 to 0.002 inch) | 0.10 (0.004 inch) |
| Exhaust | 0.05 to 0.09 mm (0.0019 to 0.003 inch) | 0.15 mm (0.006 inch) |
| Valve Face Angle | 45° to 45° 30' | — |
| Valve Overall Length | | |
| Intake | 103.0 mm (4.055 inches) | — |
| Exhaust | 102.7 mm (4.043 inches) | — |
| Valve Stem Diameter | | |
| Intake | 7.960 to 7.975 mm (0.313 to 0.314 inch) | — |
| Exhaust | 7.930 to 7.950 mm (0.312 to 0.3125 inch) | — |
| Valve Guide | | |
| Overall Length | | |
| Intake | 44 mm (1.732 inches) | — |
| Exhaust | 48 mm (1.889 inches) | — |
| O.D. | 13.055 to 13.065 mm (0.514 to 0.5143 inch) | — |
| I.D. | 8.000 to 8.018 mm (0.314 to 0.315 inch) | — |
| Valve Seat | | |
| Seat Surface Angle | 44° to 44° 3' | — |
| Contact Width | 0.9 to 1.3 mm (0.035 to 0.051 inch) | — |
| Sinkage | — | 0.2 mm (0.078 inch) |
| Valve Spring | | |
| Free Height | 49.8 mm (1.960 inches) | 48.8 |
| Loaded Height | 40.4 mm at 33 kg (1.59 inch at 73 lbs.) | — |
| Perpendicularity | | |
| Intake and Exhaust | 2° Maximum | 4° Maximum |

ENGINE SPECIFICATIONS (CONT.)

| Description | Standard Dimension | Service Limit |
|--|--|-------------------------|
| Piston | | |
| O.D. | 91.06 to 91.09mm (3.585 to 3.586 inches) | — |
| Piston to Cylinder Clearance | 0.03 to 0.05mm (0.0012 to 0.002 inch) | — |
| Ring End Gap | | |
| No. 1 | 0.30 to 0.45mm (0.012 to 0.018 inch) | 0.8mm (0.03 inch) |
| No. 2 | 0.25 to 0.40mm (0.010 to 0.016 inch) | 0.8mm (0.03 inch) |
| Oil | 0.30 to 0.90mm (0.012 to 0.035 inch) | 1.0mm (0.039 inch) |
| Ring Side Clearance | | |
| No. 1 | 0.05 to 0.09mm (0.002 to 0.0035 inch) | 0.1mm (0.0039 inch) |
| No. 2 | 0.02 to 0.06mm (0.0008 to 0.002 inch) | 0.1mm (0.0039 inch) |
| Oversize Service Pistons | 0.25 to 0.50mm (0.010 to 0.020 inch) 0.75 to 1.00mm (0.030 to 0.039 inch) | |
| Connecting Rod | | |
| Length—Center to Center | 140.9 to 141.0mm (5.547 to 5.551 inches) | — |
| Parallelism—Twist | 0.05mm (0.0019 inch) | — |
| Torsion | 0.1mm (0.0039 inch) | — |
| Big End Thrust Clearance | 0.10 to 0.25mm (0.004 to 0.010 inch) | 0.4mm (0.016 inch) |
| Crankshaft | | |
| End Play | 0.05 to 0.25mm (0.002 to 0.010 inch) | 0.3mm (0.012 inch) |
| Main Journal Diameter | 59.980 to 60.000mm (2.361 to 2.362 inches) | — |
| Pin Diameter | 49.980 to 50.000mm (1.968 to 1.969 inches) | — |
| Bearing Surface Out-of-Round | 0.03mm Max. (0.001 inch) Max. | — |
| Bearing Surface Taper | 0.005mm Max. (0.0002 inch) Max. | — |
| Bearing Oil Clearance | 0.015 to 0.050 mm (0.0006 to 0.002 inch) | — |
| Undersize Service Bearings | 0.25 to 0.50—0.75mm (0.010 to 0.020—0.030 inch) | |
| Cylinder Block | | |
| I.D. (Bore) | 91.1 mm (3.587 inches) | — |
| Flatness of Top Surface | 0.05mm (0.002 inch) | 0.1mm (0.0039 inch) |
| Grinding Limit of Top Surface | 0.2mm* (0.008 inch) | 0.2mm* (0.008 inch) |
| *Includes/Combined With Cylinder Head Grinding | | |
| Oil Pump | | |
| Relief Valve Opening Pressure | 5.0 to 6.0 kg/cm ² (71.45 to 85.75 psi) | — |
| Outer Rotor to Case Clearance | 0.10 to 0.18mm (0.004 to 0.007 inch) | 0.18mm (0.007 inch) |
| Rotor End Clearance | 0.04 to 0.09mm (0.0015 to 0.0035 inch) | 0.09mm (0.0035 inch) |
| Inner Rotor Pilot to Case Clearance | 0.03 to 0.07mm (0.001 to 0.0028 inch) | 0.15mm (0.006 inch) |



TORQUE

| Description | N·m | Ft. Lbs. | In. Lbs. |
|---|-----|----------|----------|
| Engine Support Bracket | 45 | 35 | — |
| Crankshaft Pulley A (Crankshaft Bolt) | 151 | 112 | — |
| Crankshaft Pulley B | 25 | — | 250 |
| Crankshaft Bearing Cap | 80 | 60 | — |
| Connecting Rod Cap | 52 | 38 | — |
| Camshaft Sprocket | 95 | 70 | — |
| Timing Belt Tensioner | 25 | — | 250 |
| Alternator Bracket | 25 | — | 250 |
| Rocker Cover | 10 | — | 88 |
| Distributor Adaptor | 13 | — | 120 |
| Camshaft Bearing Cap | 20 | — | 180 |
| Cylinder Head Bolt (Cold) | 108 | 80 | — |
| Oil Pan | 6 | — | 50 |
| Oil Drain Plug | 40 | 30 | — |
| Oil Pickup | 22 | — | 191 |
| Oil Pump Assembly | 15 | — | 130 |
| Oil Seal Rear Housing | 11 | — | 95 |

9109-133

3.3L ENGINE

INDEX

| | page | | page |
|--|------|---|------|
| Camshaft | 96 | Engine Mounts | 83 |
| Camshaft Bearings—Engine Removed From Vehicle | 97 | Engine Specifications | 111 |
| Checking Engine Oil Pressure | 110 | General Information | 82 |
| Connecting Rods | 103 | Hydraulic Tappets | 92 |
| Crankshaft Oil Seals Service | 106 | Installing Piston and Connecting Rod Assembly | 102 |
| Crankshaft Service | 103 | Intake Manifold Sealing | 88 |
| Cylinder Block, Piston and Connecting Rod Assembly Service | 99 | Oil Filter | 110 |
| Cylinder Heads | 86 | Oil Pan Service | 107 |
| Engine Assembly | 85 | Oil Pump Service | 108 |
| Engine Core Oil and Cam Plugs | 98 | Rocker Arms and Shaft Assembly | 86 |
| Engine Lubrication System | 107 | Timing Chain Cover, Oil Seal and Chain | 94 |
| | | Valve Service | 89 |
| | | Valve Timing | 93 |

SPECIFICATIONS

| | |
|---------------------------|--|
| Type | 60° V-6 Engine |
| Bore | 93.0 mm (3.661 Inch) |
| Stroke | 81.0 mm (3.188 Inch) |
| Compression Ratio | 8.9:1 |
| Displacement | 3.3 Liters (201 Cubic Inch) |
| Brake Horsepower | 147 @ 4800 RPM |
| Torque | 185 Lb. Ft. @ 3600 RPM |
| Firing Order | 1-2-3-4-5-6 |
| Lubrication | Pressure Feed-Full Flow Filtration (Direct Crankshaft Driven Pump) |
| Engine Oil Capacity | 4.25 Liters (4.5 Qts.) Including Oil Filter, 3.8 Liter (4.0 Qts.) Without Oil Filter |
| Cooling System | Liquid Cooled-Forced Circulation |
| Cylinder Block | Cast Iron |
| Crankshaft | Nodular Iron |
| Cylinder Head | Aluminum Alloy |
| Connecting Rods | Forged Steel |
| Pistons | Aluminum Alloy |

9209-91

GENERAL INFORMATION

ENGINE IDENTIFICATION NUMBER OR CODE

The engine identification number is located on the rear of the cylinder block just below the cylinder head (Fig. 2).

ENGINE: The 3.3L (201 Cubic Inches.) displacement engines are 60° V type six cylinder power plant with cast iron cylinder block and aluminum cylinder heads (Fig. 1). Firing order for these engines is 1-2-3-4-5-6. High turbulence cylinder heads allow a 8.9-1 compression ratio.

CRANKSHAFT: The nodular iron crankshaft is supported by four main bearings, with number two

being the thrust bearing. Crankshaft end sealing is provided by front and rear rubber seal.

PISTONS: The pistons are cast aluminum alloy. Three rings are used. Piston pins, press fitted into place, join the pistons to forged steel connecting rods.

CAMSHAFTS: The cast iron camshaft is mounted in four steel backed babbitt bearings. A thrust plate located in front of the first bearing, and bolted to the block, controls end play. Silent timing chain drives the camshaft. This chain is enclosed by a cast aluminum cover which also carries a front crankshaft seal, provides front oil pan closure, water pump mounting.

CYLINDER HEADS: Cylinder heads incorporate valve shrouding to create turbulence-producing combustion chambers, described as fast burn. Sintered

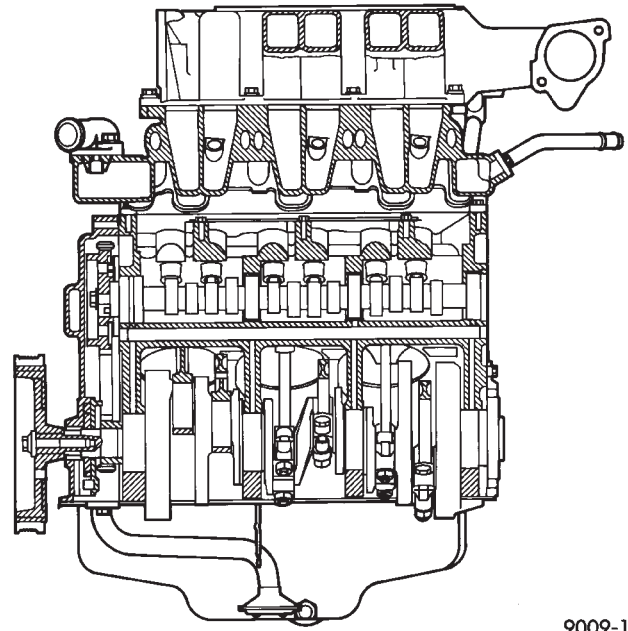
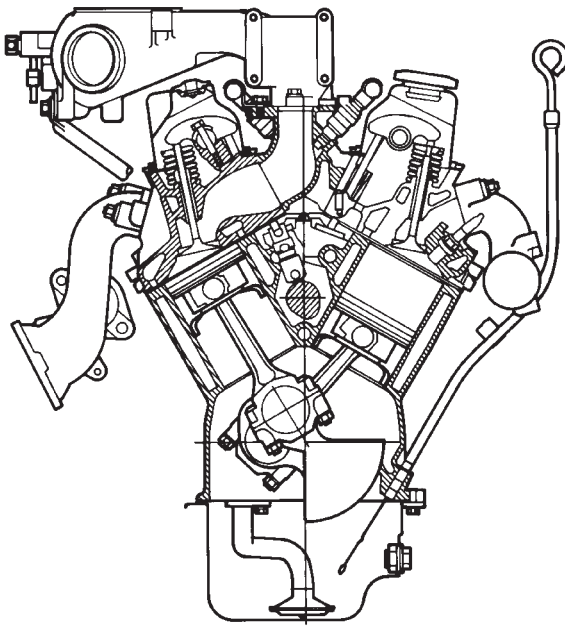

9009-1

Fig. 1 3.3L Engine

The intake manifold is also cored with upper level EGR passages for balanced cylinder to cylinder EGR distribution.

VALVE TRAIN: Valve train design incorporates the use of hydraulic roller tappets. Rocker arms are installed on a rocker arm shaft attached to the cylinder head with four bolts and retainers. Viton valve stem seals provide valve sealing. Unique beehive style valve spring are used with lightweight retainers for improved high RPM performance.

EXHAUST MANIFOLDS: Exhaust manifolds are log type with a crossover and is attached directly to the cylinder heads.

ENGINE MOUNTS

REMOVAL AND INSTALLATION

RIGHT SIDE MOUNT

- (1) Remove the right engine mount insulator vertical fasteners from frame rail.
- (2) Remove the load on the engine motor mounts by carefully supporting the engine and transmission assembly with a floor jack.
- (3) Remove the thru bolt from the insulator assembly. Remove insulator.
- (4) Reverse removal procedure for installation. Refer to (Fig. 3) for bolt tightening specifications.
- (5) Engine mount adjustment, Refer to Engine Mount Insulator Adjustment of this section.

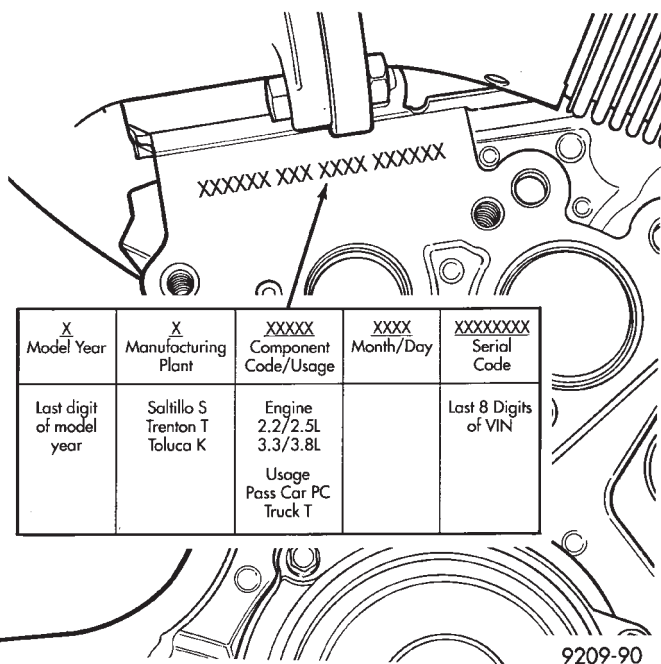

Fig. 2 Engine Identification

valve seat inserts are used. A steel flanged composition type gasket is used between head and block.

VALVE COVERS: The covers are sealed with steel reinforced silicon rubber gaskets.

INTAKE MANIFOLD: The intake manifold is a tuned two-piece semi-permanent mold aluminum casting with individual primary runners leading from a plenum to the cylinders. The manifold is designed to boost torque in the 3600 rpm range and contributes to the engine's broad, flat torque curve, which was desired for excellent engine tractability, response and usable power output.



| TORQUE | |
|--------|------------------------|
| A | 68 N·m (50 FT. LBS.) |
| B | 149 N·m (110 FT. LBS.) |
| C | 102 N·m (75 FT. LBS.) |
| D | 23 N·m (200 IN. LBS.) |
| E | 54 N·m (40 FT. LBS.) |

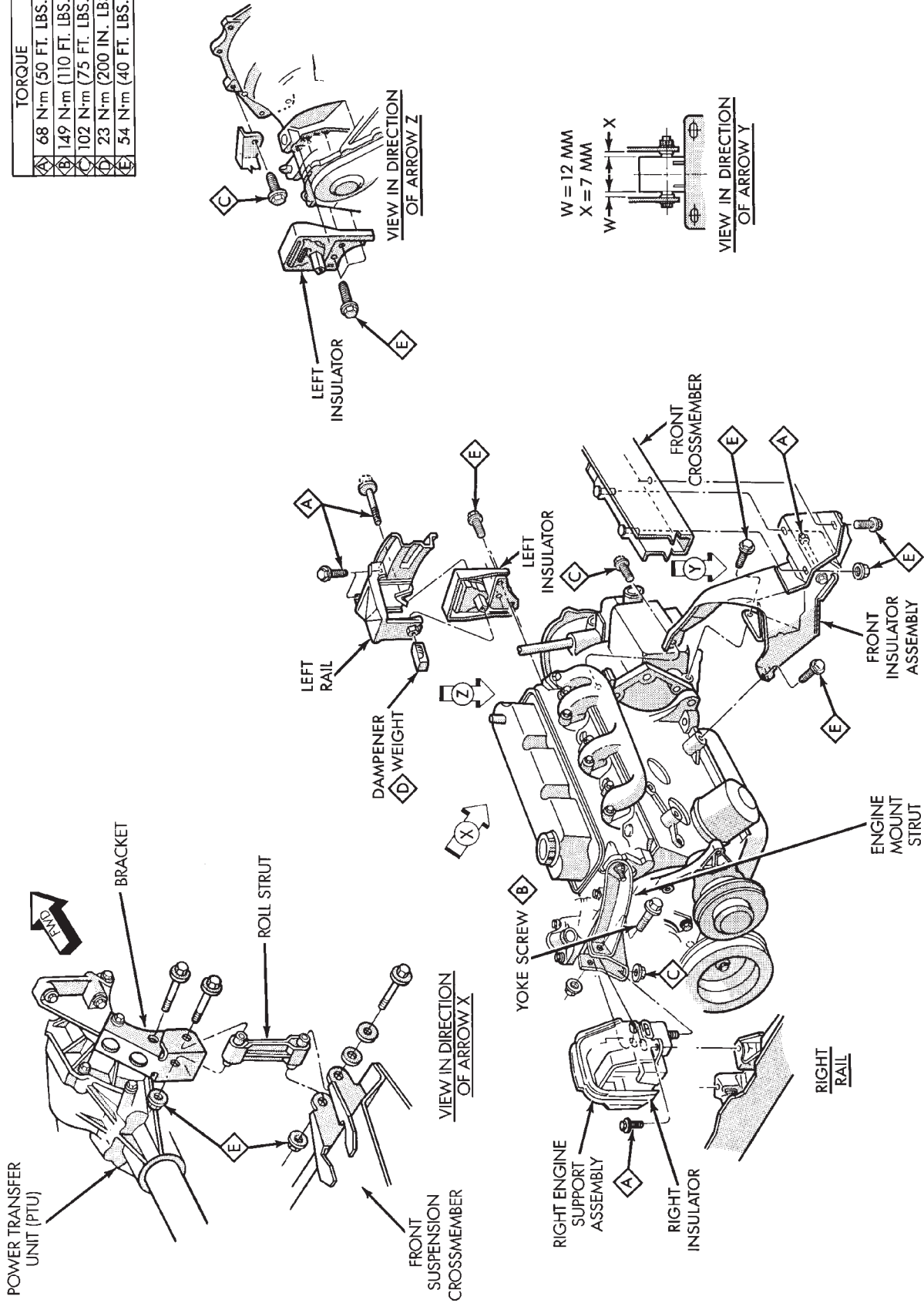

Fig. 3 Engine Mounting

FRONT MOUNT

- (1) Support the engine and transmission assembly with a floor jack so it will not rotate.
- (2) Remove the thru bolt from the insulator and front crossmember mounting bracket.
- (3) Remove the front engine mount bracket to front crossmember screws and nuts. Remove the insulator assembly.
- (4) Reverse removal procedure for installation. Refer to (Fig. 3) for bolt tightening specifications.
- (5) Engine mount adjustment, Refer to Engine Mount Insulator Adjustment of this section.

LEFT SIDE MOUNT

- (1) Raise vehicle on hoist and remove left front wheel.
- (2) Remove inter splash shield.
- (3) Support the transmission with a transmission jack.
- (4) Remove the insulator thru bolt from the mount.
- (5) Remove the transmission mount fasteners and remove mount.
- (6) Reverse removal procedure for installation. Refer to (Fig. 3) for bolt tightening specifications.
- (7) Engine mount adjustment, Refer to Engine Mount Insulator Adjustment of this section.

ENGINE MOUNT RUBBER INSULATORS

Insulator location on frame rail (right side) and transmission bracket (left side) are adjustable to allow right/left drive train adjustment in relation to drive shaft assembly length.

Check and reposition right engine mount insulator (left engine mount insulator is floating type and will adjust automatically (Fig. 4). Adjust drive train position, if required, for the following conditions:

- Drive shaft distress: See Driveshafts in Suspension, Group 2.
- Any front end structural damage (after repair).
- Insulator replacement.

ENGINE MOUNT INSULATOR ADJUSTMENT

- (1) Remove the load on the engine motor mounts by carefully supporting the engine and transmission assembly with a floor jack.
- (2) Loosen the right engine mount insulator vertical fasteners, and the front engine mount bracket to front crossmember screws and nuts.

Left engine mount insulator is sleeved over shaft and long support bolt to provide lateral movement adjustment with engine weight removed or not.

- (3) Pry the engine right or left as required to achieve the proper drive shaft assembly length. See Drive

Shaft in Suspension Group 2 for driveshaft identification and related assembly length measuring.

- (4) Tighten right engine mount insulator vertical bolts to 37 N•m (27 ft. lbs.). Then tighten front engine mount screws and nuts to 54 N•m (40 ft. lbs.) and center left engine mount insulator.
- (5) Recheck drive shaft length.

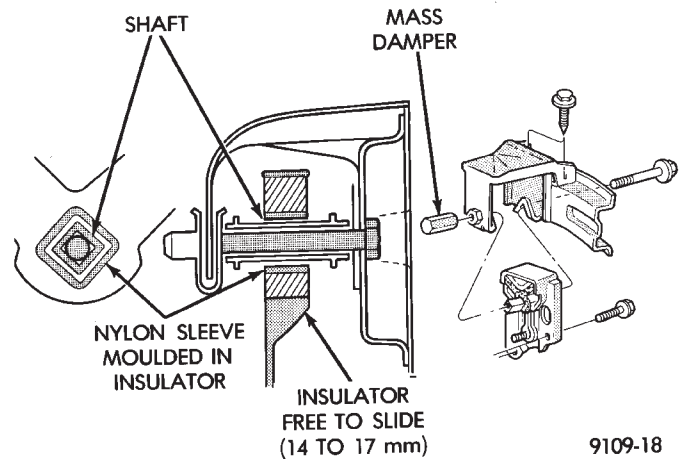

Fig. 4 Left Insulator Movement

ENGINE ASSEMBLY

REMOVAL

- (1) Disconnect battery.
- (2) Mark hood position at hinges and remove hood.
- (3) Drain cooling system. Refer to Cooling System, Group 7 for procedure.
- (4) Disconnect all electrical connections.
- (5) Remove coolant hoses from radiator and engine.
- (6) Remove radiator and fan assembly.
- (7) See Fuel System, Group 14, to release fuel pressure. Disconnect fuel lines and accelerator cable.
- (8) Remove air cleaner assembly.
- (9) Hoist vehicle and drain engine oil.
- (10) Remove air conditioning compressor mounting bolts and set compressor aside.
- (11) Disconnect exhaust pipe at manifold.
- (12) Remove transmission inspection cover and mark flex plate to torque converter position. For disassembly procedure for the all wheel drive vehicle refer to Group 21 Transaxle.
- (13) Remove screws holding torque converter to flex plate and attach C-clamp on bottom of converter housing to prevent torque converter from counting out.
- (14) Remove power steering pump mounting bolts and set pump aside.
- (15) Remove two lower transmission to block screws.
- (16) Remove starter.
- (17) Lower vehicles and disconnect vacuum lines and ground strap.
- (18) Install transmission holding fixture.

- (19) Attach engine lifting hoist and support engine.
- (20) Remove upper transmission case to block bolts.
- (21) See Engine Mounting in (Fig. 3) and separate mount/insulators as follows:
 - (a) Mark RIGHT insulator on right rails supports. Remove insulator to rails screws.
 - (b) Remove FRONT engine mount through bolt and nut.
 - (c) Remove LEFT insulator through bolt from inside wheelhouse or insulator bracket to transmission screws.
- (22) Remove engine.

INSTALLATION

- (1) Attach hoist and lower engine into engine compartment.
- (2) Align engine mounts and install but **do not tighten** until all mounting bolts have been installed. Tighten bolts to torque specified in (Fig. 3).
- (3) Install transmission case to cylinder block, tighten bolts to 102 N•m (75 ft. lbs.) torque.
- (4) Remove engine hoist and transmission holding fixture.
- (5) Remove C-clamp from torque converter housing. Align flex plate to torque converter and install mounting screws. Tighten to 75 N•m (55 ft. lbs.) torque. Refer to Group 21 transaxle for the all wheel drive installation procedure.
- (6) Install transmission inspection cover.
- (7) Connect exhaust system at manifold.
- (8) Install starter.
- (9) Install power steering pump and air conditioning compressor. For belt installation see Accessory Belt Drive in Cooling System Group 7.
- (10) Lower vehicle and connect all vacuum lines.
- (11) Connect all electrical connections including ground strap.
- (12) Connect fuel lines and accelerator cable.
- (13) Install radiator and fan assembly. Reconnect fan motor electrical lead. Reinstall radiator hoses. Fill cooling system. See Cooling System Group 7 for filling procedure.
- (14) Fill engine crankcase with proper oil to correct level.
- (15) Install hood.
- (16) Connect battery.
- (17) Start engine and run until operating temperature is reached.
- (18) Adjust transmission or linkage if necessary.

ROCKER ARMS AND SHAFT ASSEMBLY

REMOVAL

- (1) Remove upper intake manifold assembly. Refer to Intake and Exhaust Manifolds, Group 11.
- (2) Disconnect spark plug wires by pulling on the boot straight out in line with plug.

- (3) Disconnect closed ventilation system and evaporation control system from cylinder head cover.
- (4) Remove cylinder head cover and gasket.
- (5) Remove four rocker shaft bolts and retainers.
- (6) Remove rocker arms and shaft assembly.
- (7) If rocker arm assemblies are disassembled for cleaning or replacement. Assemble rocker arms in their original position refer to (Fig. 5) for rocker arm for positioning on the shaft.

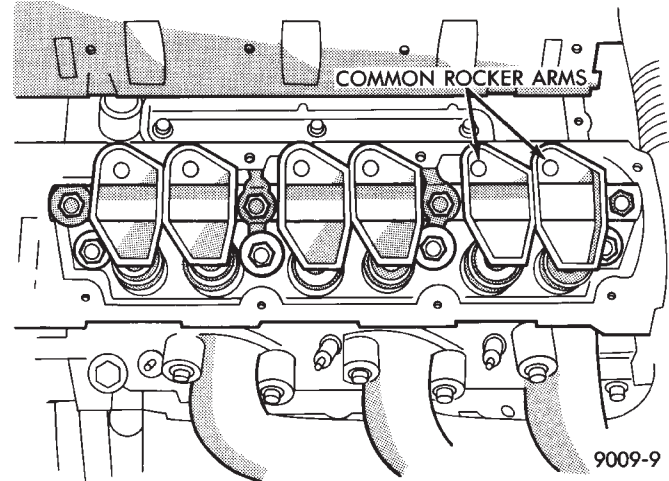

Fig. 5 Rocker Arm Location Left Blank

INSTALLATION

- (1) Install rocker arm and shaft assemblies with the stamped steel retainers in the four positions, tighten to 28 N•m (250 in. lbs.) (Fig. 5).
- WARNING: THE ROCKER ARM SHAFT SHOULD BE TORQUED DOWN SLOWLY, STARTING WITH THE CENTERMOST BOLTS. ALLOW 20 MINUTES TAPPET BLEED DOWN TIME AFTER INSTALLATION OF THE ROCKER SHAFTS BEFORE ENGINE OPERATION.**
- (2) Clean cylinder head cover gasket surface. Inspect cover for distortion and straighten if necessary.
 - (3) Clean head rail if necessary. Install a new gasket and tighten cylinder head cover fasteners to 12 N•m (105 in. lbs.).
 - (4) Install closed crankcase ventilation system and evaporation control system.
 - (5) Install spark plug wires.
 - (6) Install upper intake manifold assembly. Refer to Exhaust Systems and Intake Manifolds Group 11.

CYLINDER HEADS

The alloy aluminum cylinder heads shown in (Fig. 6) are held in place by 9 bolts. The spark plugs are located in peak of the wedge between the valves.

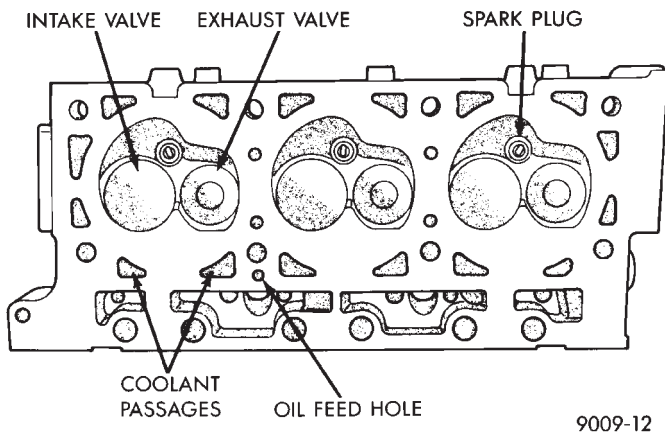

Fig. 6 Cylinder Head Assembly

REMOVAL

(1) Drain cooling system refer to Cooling System Group 7 for procedure and disconnect negative battery cable.

Remove intake manifold, and throttle body. Refer to Group 11 Exhaust System and Intake Manifold.

(2) Disconnect coil wires, sending unit wire, heater hoses and by-pass hose.

(3) Remove closed ventilation system, evaporation control system and cylinder head covers.

(4) Remove exhaust manifolds.

(5) Remove rocker arm and shaft assemblies. Remove push rods and **identify to insure installation in original locations.**

(6) Remove the 9 head bolts from each cylinder head and remove cylinder heads (Fig. 7).

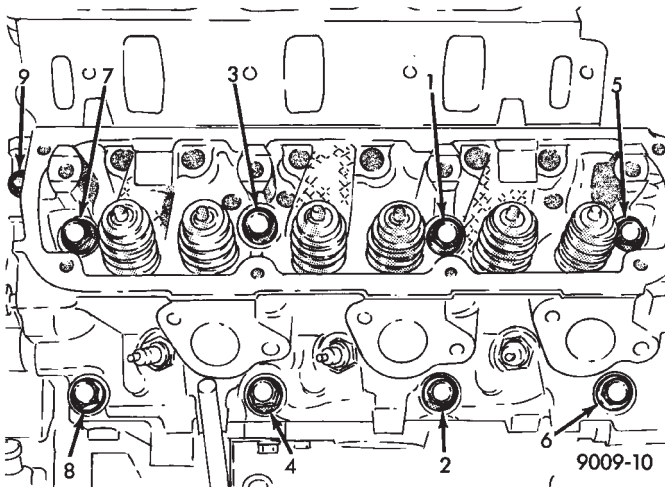

Fig. 7 Cylinder Head Bolts Location

INSPECTION

(1) Before cleaning, check for leaks, damage and cracks.

(2) Clean cylinder head and oil passages.

(3) Check cylinder head for flatness (Fig. 8).

(4) Inspect all surfaces with a straightedge if there is any reason to suspect leakage. If out of flatness exceeds .019mm (.00075 inch), times the span length in inches

in any direction, either replace head or lightly machine the head surface. As an example, if a 12 inch span is 1mm (.004 inch) out of flat, allowable is $12 \times .019\text{mm}$ (.00075 inch) equals .22mm (.009 in.) This amount of out of flat is acceptable.

*Maximum of 0.2 mm (.008 inch) for grinding is permitted.

CAUTION: This is a combined total dimension of stock removal from cylinder head and block top surface.

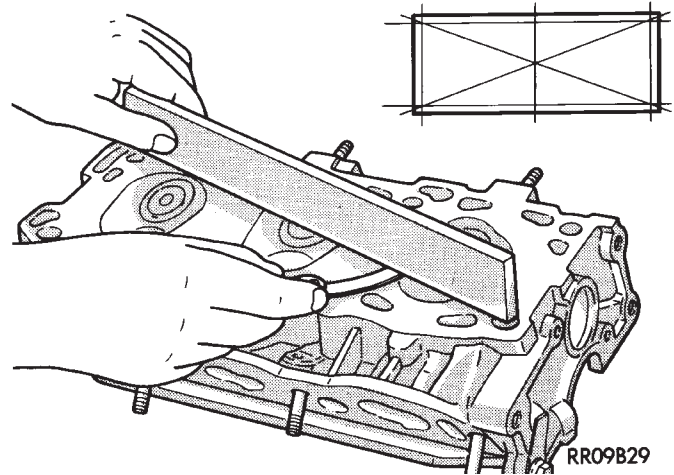

Fig. 8 Check Cylinder Head

INSTALLATION

(1) Clean all surfaces of cylinder block and cylinder heads.

(2) Install new gaskets on cylinder block (Fig. 9).

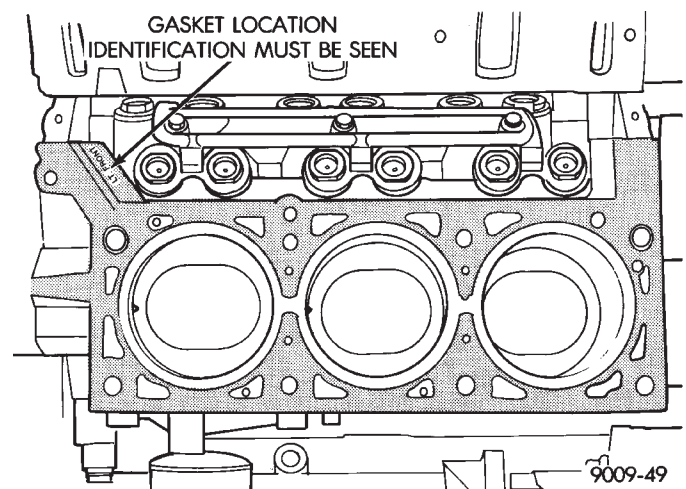

Fig. 9 Head Gasket Installation

The Cylinder head bolts are torqued using the torque yield method, they should be examined **BEFORE** reuse. If the threads are necked down, the bolts should be replaced (Fig. 10).

Necking can be checked by holding a scale or straight edge against the threads. If all the threads do not contact the scale the bolt should be replaced.

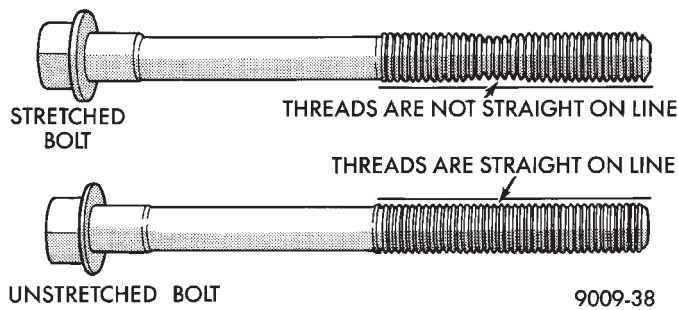

Fig. 10 Checking Bolts for Stretching (Necking)

(3) Tighten the cylinder head bolts 1 thru 8 in the sequence shown in (Fig. 11). Using the 4 step torque turn method, tighten according to the following values:

- First-All to 61 N•m (45 ft. lbs.)
- Second-All to 88 N•m (65 ft. lbs.)
- Third-All (again) to 88 N•m (65 ft. lbs.)
- Fourth + 1/4 Turn **Do not use a torque wrench for this step**

(4) Bolt torque after 1/4 turn should be over 122 N•m(90 ft. lbs.). If not, replace the bolt.

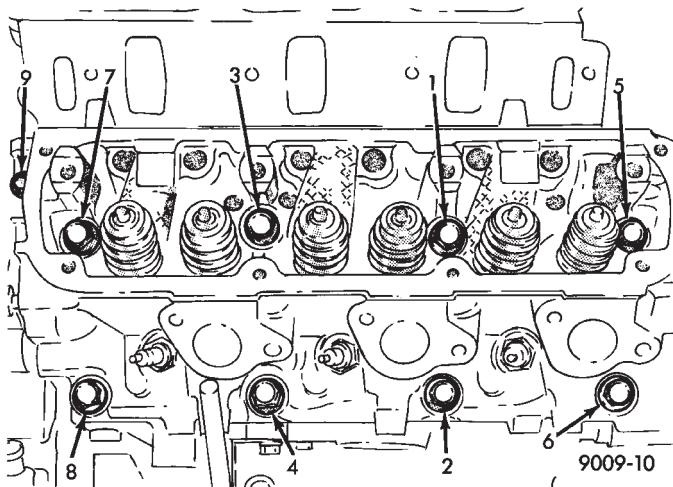

Fig. 11 Cylinder Head Tightening Sequence

(5) Tighten head bolt number 9 (Fig. 11) to 33 N•m (25 ft. lbs.) after head bolts 1 thru 8 have been tightened to specifications.

(6) Inspect push rods and replace worn or bent rods.

(7) Install push rods, rocker arm and shaft assemblies with the stamped steel retainers in the four positions, tighten to 28 N•m (250 in. lbs.) (Fig. 12).

(8) Place new cylinder head cover gaskets in position and install cylinder head covers. Tighten to 12 N•m (105 in. lbs.).

INTAKE MANIFOLD SEALING

The intake manifold gasket is a one-piece stamped steel gasket with a sealer applied from the manufacturer. This gasket has end seals incorporated with it.

WARNING: INTAKE MANIFOLD GASKET IS MADE OF VERY THIN METAL AND MAY CAUSE PERSONAL INJURY, HANDLE WITH CARE.

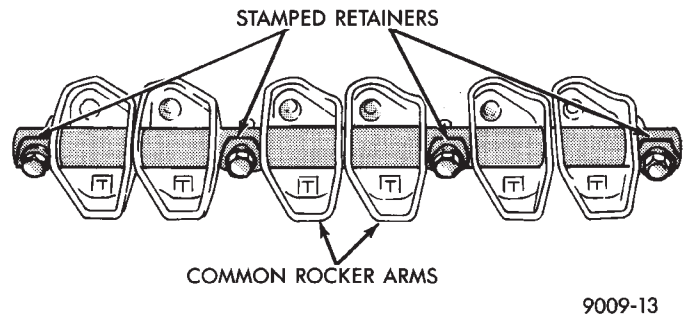

Fig. 12 Rocker Arm Shaft Retainers

(1) Clean all surfaces of cylinder block and cylinder heads.

(2) Place a drop (about 1/4 in. diameter) of Mopar Silicone Rubber Adhesive Sealant or equivalent, onto each of the **four** manifold to cylinder head gasket corners (Fig. 13).

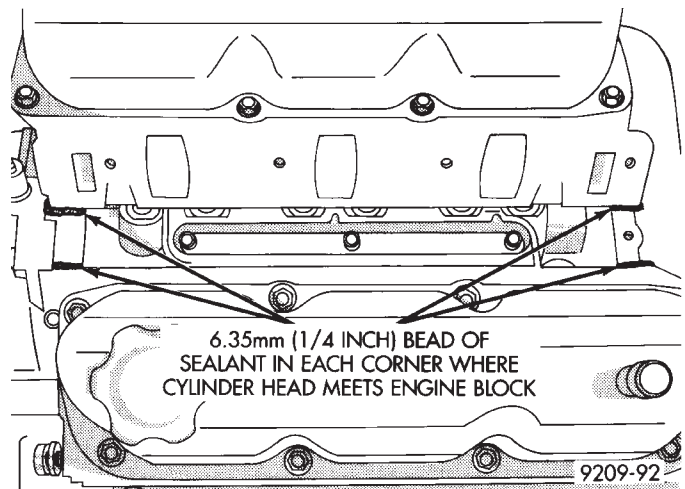

Fig. 13 Intake Manifold Gasket Sealing

(3) Carefully install the intake manifold gasket (Fig. 14). Torque end seal retainer screws to 12 N•m (105 in. lbs.).

(4) Install intake manifold and (8) bolts and torque to 1 N•m (10 in. lbs.). Then retorque bolts to 22 N•m (200 in. lbs.) in sequence shown in (Fig. 15). Then retorque again to 22 N•m (200 in. lbs.). After intake manifold is in place, **inspect to make sure seals are in place**. Refer to Group 11 Exhaust System and Intake Manifold to complete Intake Manifold Assembly.

(5) Install exhaust manifolds and tighten bolts to 27 N•m (20 ft. lb.) and nuts to 20 N•m (15 ft. lbs.).

(6) Adjust spark plugs to specification in Electrical Section, Group 8, and install the plugs.

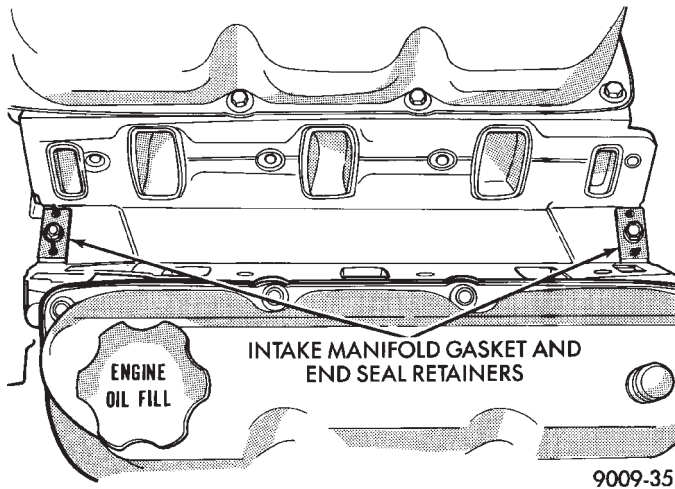

Fig. 14 Intake Manifold Gasket Retainers

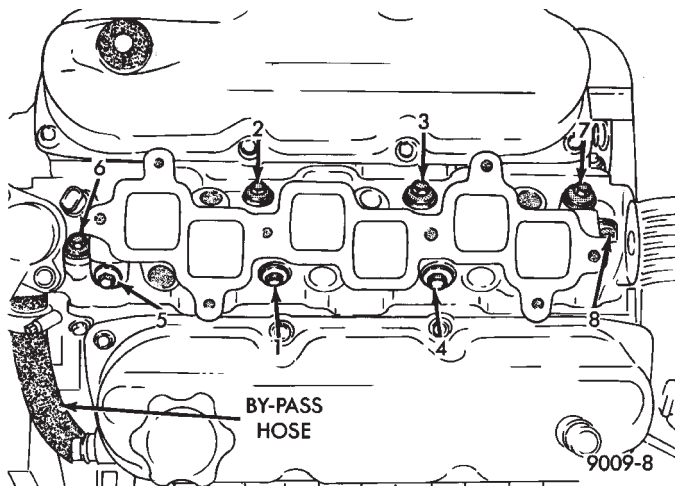

Fig. 15 Intake Manifold Removal and Installation

VALVE SERVICE

VALVES AND VALVE SPRINGS

The valves are arranged in line in the cylinder heads and inclined 18 degrees. The rocker shaft support and the valve guides are cast integral with the heads.

REMOVAL

(1) With cylinder head removed, compress valve springs using Valve Spring Compressor Tool C-3422-B with adapter 6412 as shown in (Fig. 16).

(2) Remove valve retaining locks, valve spring retainers, valve stem cup seals and valve springs.

(3) Before removing valves, **remove any burrs from valve stem lock grooves to prevent damage to the valve guides.** Identify valves to insure installation in original location.

VALVE INSPECTION

(1) Clean valves thoroughly and discard burned, warped and cracked valves.

(2) Measure valve stems for wear. Refer to specifications (Fig. 19).

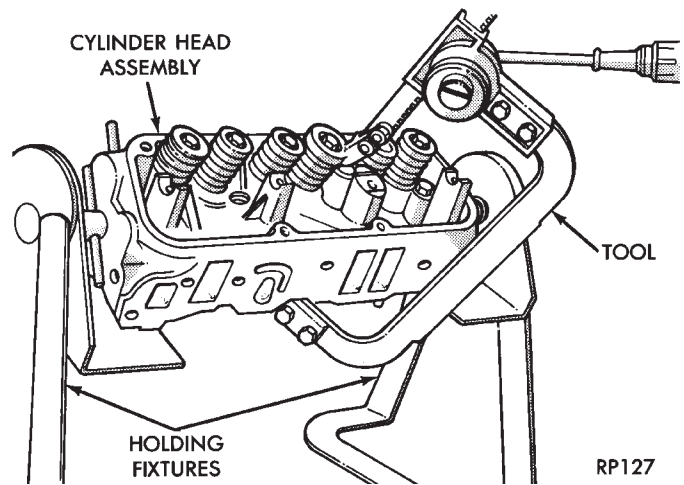

Fig. 16 Compress Valve Springs with Special Tool C-3422B with adapter 6412

Valve stems are chrome plated and should not be polished.

(3) Remove carbon and varnish deposits from inside of valve guides with a reliable guide cleaner.

(4) Measure valve stem guide clearance as follows:

(a) Install valve into cylinder head so it is 14mm (.551 inch) off the valve seat. A small piece of hose may be used to hold valve in place.

(b) Attach dial indicator Tool C-3339 to cylinder head and set it at right angle of valve stem being measured (Fig. 17).

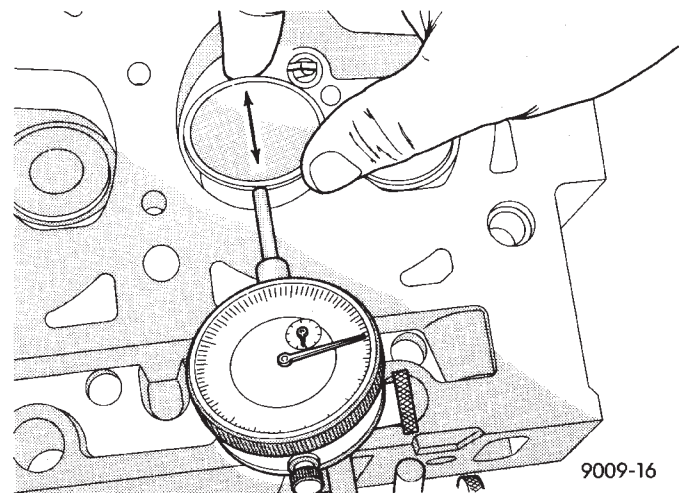

Fig. 17 Measuring Valve Guide Wear

(c) Move valve to and from the indicator. Refer to specifications (Fig. 19).

Ream the guides for valves with oversized stems if dial indicator reading is excessive or if the stems are scuffed or scored.

(5) Service valves with oversize stems and over size seals are available in 0.15mm (.005 inch), 0.40mm, (.015 inch) and 0.80mm (.030 inch) oversize.

Oversize seals must be used with oversize valves.

Reamers to accommodate the oversize valve stem are as follows:

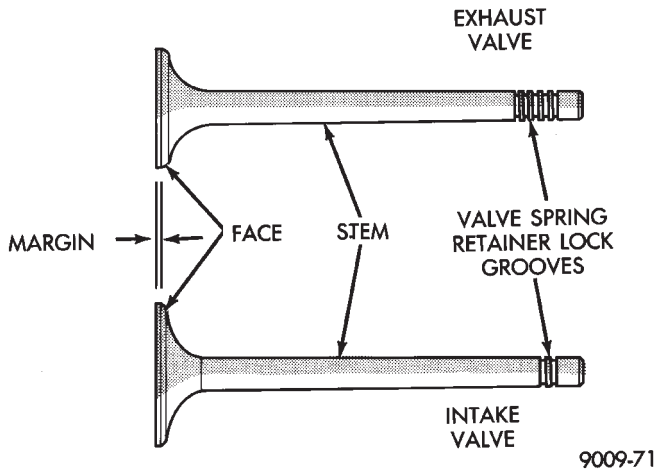

Fig. 18 Intake and Exhaust Valves

| Valve Dimensions | |
|--------------------------------|-----------------------|
| Intake Valve (minimum) | |
| Stem diameter: | 7.935 mm (.3124 in.) |
| Face angle: | 44 1/2° |
| Valve margin: | .794 mm (.031 in.) |
| Head diameter: | 45.5 mm (1.79 in.) |
| Length: | 125.38 mm (4.936 in.) |
| Exhaust Valve (minimum) | |
| Stem diameter: | 7.906 mm (.3112 in.) |
| Face angle: | 44 1/2° |
| Valve margin: | 1.191 mm (.0469 in.) |
| Head diameter: | 37.5 mm (1.476 in.) |
| Length: | 126.00 mm (4.964 in.) |

9109-47

Fig. 20 Valve Dimensions

VALVES

(1) Inspect the remaining margin after the valves are refaced Refer to specifications (Fig. 20).

VALVE SEATS

CAUTION: Do not un-shroud valves during valve seat refacing (Fig. 22).

(1) When refacing valve seats, it is important that the correct size valve guide pilot be used for reseating stones. A true and complete surface must be obtained.

(2) Measure the concentricity of valve seat using dial indicator. Total runout should not exceed .051mm (.002 inch) total indicator reading.

| Valve Guide Dial Indicator Reading, Maximum | Intake Valve | Exhaust Valve |
|---|----------------------------------|----------------------|
| | 0.247 mm (0.009 in.) | 0.414 mm (0.016 in.) |
| Valve Guide Reamer Oversize | Valve Guide Size | |
| 0.15 mm (.005 in.) | 8.125-8.150 mm (.3198-.3208 in.) | |
| 0.40 mm (.015 in.) | 8.375-8.400 mm (.3297-.3307 in.) | |
| 0.80 mm (.030 in.) | 8.775-8.800 mm (.3454-.3464 in.) | |

9109-46

Fig. 19 Valve Guide Specifications

(6) Slowly turn reamer by hand and clean guide thoroughly before installing new valve. **Do not attempt to ream the valve guides from standard directly to 0.80mm (.030 inch) Use step procedure of 0.15mm (.005 inch), 0.40mm (.015 inch) and 0.80mm (.030 inch) so the valve guides may be reamed true in relation to the valve seat. After reaming guides, the seat runout should be measured and resurfaced if necessary. See Refacing Valves and Valve Seats.**

VALVE GUIDES

Replace cylinder head if guide does not clean up with 0.80mm (.030 inch) oversize reamer, or if guide is loose in cylinder head.

REFACING VALVES AND VALVE SEATS

The intake and exhaust valves have a 44-1/2 to 45 degree face angle. The valve seats have a 45 to 45-1/2 degree face angle. The valve face and valve seat angles are shown in (Fig. 21).

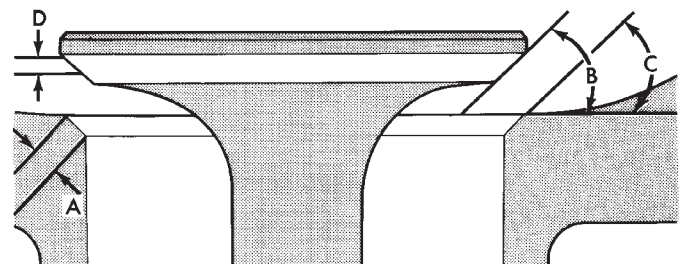

A- SEAT WIDTH (INTAKE 1.75 TO 2.25mm (.069 TO .088 IN.)
 EXHAUST: 1.50 TO 2.00mm (.059 TO .078 IN.)
 B- FACE ANGLE (INTAKE & EXHAUST: 44 1/2°)
 C- SEAT ANGLE (INTAKE & EXHAUST: 45°-45 1/2°)
 D- SEAT CONTACT AREA

9009-88

Fig. 21 Valve Seats

(3) Inspect the valve seat with Prussian blue to determine where the valve contacts the seat. To do this, coat valve seat **LIGHTLY** with Prussian blue then set valve in place. Rotate the valve with light pressure. If the blue is transferred to the center of valve face, contact is satisfactory. If the blue is transferred to top edge of valve face, lower valve seat with

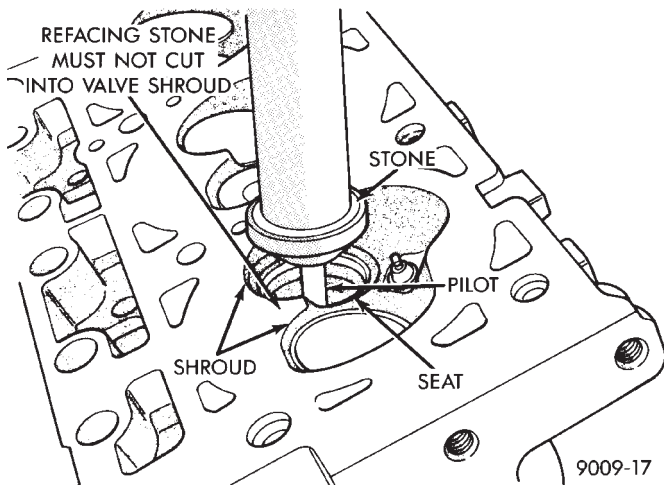

Fig. 22 Refacing Valve Seats

a 15 degree stone. If the blue is transferred to the bottom edge of valve face raise valve seat with a 65 degrees stone.

Valve seats which are worn or burned can be reworked, provided that correct angle and seat width are maintained. Otherwise cylinder head must be replaced.

(4) When seat is properly positioned the width of intake seats should be 1.75 to 2.25mm (0.69 to .088 inch) The width of the exhaust seats should be 1.50 to 2.00mm (.059 to .078 inch) (Fig. 21)

(5) Check the valve spring installed height after refacing the valve and seat (Fig. 24).

TESTING VALVE SPRINGS

Whenever valves have been removed for inspection, reconditioning or replacement, valve springs should be tested (Fig. 23). **As an example;** the compression length of the spring to be tested is 33.34mm (1-5/16 inches). Turn table of Tool C-647 until surface is in line with the 33.34mm (1-5/16 inch) mark on the threaded stud and the zero mark on the front. Place spring over stud on the table and lift compressing lever to set tone device. Pull on torque wrench until ping is heard. Take reading on torque wrench at this instant. Multiply this reading by two. This will give the spring load at test length. Fractional measurements are indicated on the table for finer adjustments. Refer to specifications to obtain specified height and allowable tensions. Discard the springs that do not meet specifications.

VALVE INSTALLATION

(1) Coat valve stems with clean engine oil and insert them in cylinder head.

(2) If valves or seats are reground, check installed valve spring height (Fig. 24).

(3) Install new cup seals on all valve stems and over valve guides (Fig. 24). Install valve springs and valve retainers.

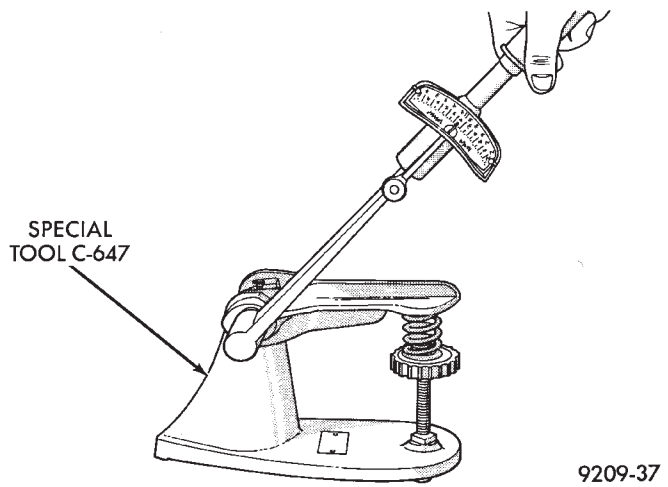

Fig. 23 Testing Valve Spring with Special Tool C-647

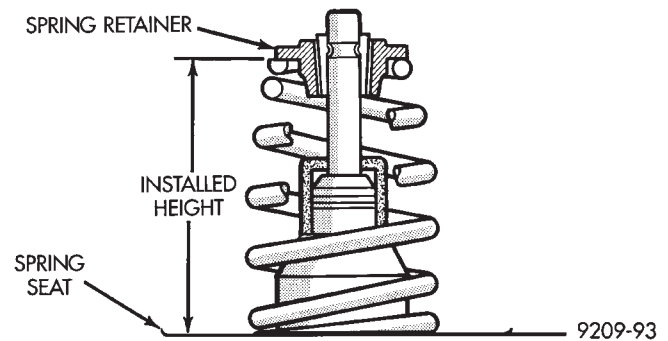

Fig. 24 Checking Valve Installed Height

(4) Compress valve springs with Valve Spring Compressor Tool C-3422-B, with adapter 6412 install locks and release tool. **If valves and/or seats are reground, measure the installed height of springs, make sure measurements is taken from top of spring seat to the bottom surface of spring retainer. If height is greater than 1-19/32 inches, (40.6mm), install a 1/32 inch (.794mm) spacer in head counterbore to bring spring height back to normal 1-17/32 to 1-19/32 inch (39.1 to 40.6mm).**

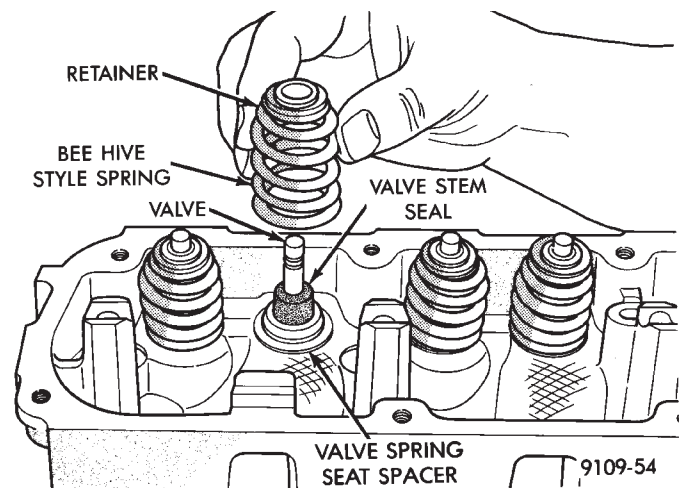

Fig. 25 Installing Valve, Cup Seal, Spring and Retainer

REPLACE VALVE STEM SEALS OR VALVE SPRINGS, CYLINDER HEAD NOT REMOVED

(1) Perform fuel system pressure release procedure **before attempting any repairs**

(2) Disconnect negative battery cable.
 (3) Remove Air Cleaner Cover and hose assembly.
 (4) Remove Intake Manifold; Refer to Intake/Exhaust Manifold 3.3L Engine Group 11 Exhaust System and Intake Manifolds of this manual for removal procedure.

(5) Remove cylinder head covers and spark plugs.
 (6) Remove connector wire from ignition coils.
 (7) Using suitable socket and flex handle at crankshaft pulley retaining screw, turn engine so the number 1 piston is at Top Dead Center on the compression stroke.

(8) Remove rocker arms with rocker shaft and install a shaft. The rocker arms should not be disturbed and left on shaft.

(9) With air hose attached to spark plug adapter installed in number 1 spark plug hole, apply 90 to 100 psi air pressure (620.5 to 689 kPa). This is to hold valves into place while servicing components.

(10) Using Tool C-4682 or Equivalent compress valve spring and remove retainer valve locks and valve spring.

(11) Install cup shields on the exhaust valve stem and position down against valve guides.

(12) The intake valve stem seals should be pushed firmly and squarely over the valve guide using the valve stem as guide. **Do Not Force** seal against top of guide. When installing the valve retainer locks, compress the spring **only enough** to install the locks.

CAUTION: Do not pinch seal between retainer and top of valve guide.

(13) Follow the same procedure on the remaining 5 cylinders using the firing sequence 1-2-3-4-5-6. **Make sure piston in cylinder is at TDC on the valve spring that is being covered.**

(14) Remove spark plug adapter tool .

(15) Remove shaft and install rocker shaft assembly and tighten screws to 28 N•m (250 in. lbs.).

(16) Install rocker arm covers tighten screws to 14 N•m (120 in. lbs.) and connector to ignition coils.

(17) Install Intake Manifold; Refer to Intake Manifold Installation 3.3L Engine, Group 11 Exhaust System and Intake Manifold.

HYDRAULIC TAPPETS

The valve train includes roller tappet assemblies, aligning yokes and yoke retainer.

Roller tappet alignment is maintained by machined flats on tappet body being fitted in pairs into six aligning yokes. The yokes are secured by an alignment yoke retainer (Fig. 26).

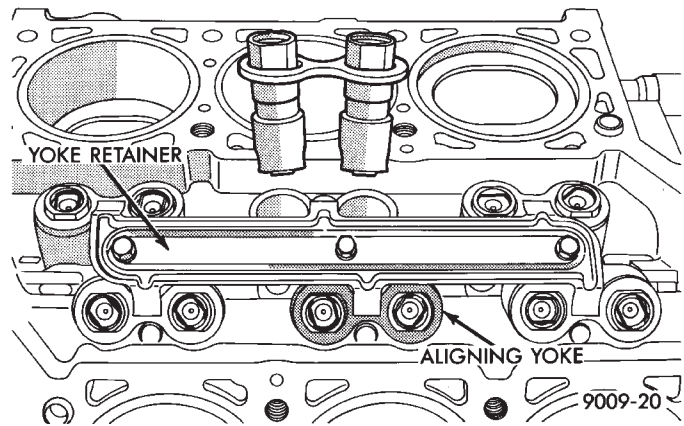

Fig. 26 Roller Tappets Aligning Yoke and Retainer

PRELIMINARY STEP TO CHECKING THE HYDRAULIC TAPPETS

Before disassembling any part of the engine to correct tappet noise, read the oil pressure at the gauge. Install a reliable gauge at pressure sending unit if vehicle has no oil pressure gauge and check the oil level in the oil pan. The pressure should be between 30 and 80 psi (206.8 to 551.6 kPa) at 2000 rpm.

The oil level in the pan should never be above the MAX mark on dipstick, or below the MIN mark. Either of these two conditions could be responsible for noisy tappets. **Oil Level Check: stop engine after reaching normal operating temperature.** Allow 5 minutes to stabilize oil level, check dipstick.

OIL LEVEL TOO HIGH

If oil level is above the MAX mark on dip stick, it is possible for the connecting rods to dip into the oil while engine is running and create foam. Foam in oil pan would be fed to the hydraulic tappets by the oil pump causing them to lose length and allow valves to seat noisily.

OIL LEVEL TOO LOW

Low oil level may allow pump to take in air which when fed to the tappets, causes them to lose length and allows valves to seat noisily. Any leaks on intake side of pump through which air can be drawn will create the same tappet action. Check the lubrication system from the intake strainer to the pump cover, including the relief valve retainer cap. When tappet noise is due to aeration, it may be intermittent or constant, and usually more than one tappet will be noisy. When oil level and leaks have been corrected, engine should be operated at fast idle for sufficient time to allow all of the air inside of the tappets to be bled out.

TAPPET NOISE DIAGNOSIS

(1) To determine source of tappet noise, operate engine at idle with cylinder head covers removed.

(2) Feel each valve spring or rocker arm to detect noisy tappet. The noisy tappet will cause the affected spring and/or rocker arm to vibrate or feel rough in operation.

Worn valve guides or cocked springs are sometimes mistaken for noisy tappets. If such is the case, noise may be dampened by applying side thrust on the valve spring. If noise is not appreciably reduced, it can be assumed the noise is in the tappet. Inspect the rocker arm push rod sockets and push rod ends for wear.

(3) Valve tappet noise ranges from light noise to a heavy click. A light noise is usually caused by excessive leakdown around the unit plunger which will necessitate replacing the tappet, or by the plunger partially sticking in the tappet body cylinder. A heavy click is caused either by a tappet check valve not seating, or by foreign particles becoming wedged between the plunger and the tappet body, causing the plunger to stick in the down position. This heavy click will be accompanied by excessive clearance between the valve stem and rocker arm as valve closes. In either case, tappet assembly should be removed for inspection and cleaning.

TAPPET REMOVAL

(1) Refer to Cylinder Head Removal of this section to remove intake manifold and cylinder heads for access to tappets for service.

(2) Remove yoke retainer and aligning yokes.

(3) Use Tool C-4129 to remove tappets from their bores. If all tappets are to be removed, identify tappets to insure installation in original location.

If the tappet or bore in cylinder block is scored, scuffed, or shows signs of sticking, ream the bore to next oversize and replace with oversize tappet.

CAUTION: The plunger and tappet bodies are not interchangeable. The plunger and valve must always be fitted to the original body. It is advisable to work on one tappet at a time to avoid mixing of parts. Mixed parts are not compatible. Do not disassemble a tappet on a dirty work bench.

DISASSEMBLY (FIG. 27)

(1) Pry out plunger retainer spring clip.

(2) Clean varnish deposits from inside of tappet body above plunger cap.

(3) Invert tappet body and remove plunger cap, plunger, flat or ball check valve, check valve spring, check valve retainer and plunger spring. Check valve could be flat or ball.

CLEANING AND ASSEMBLY

(1) Clean all tappet parts in a solvent that will remove all varnish and carbon.

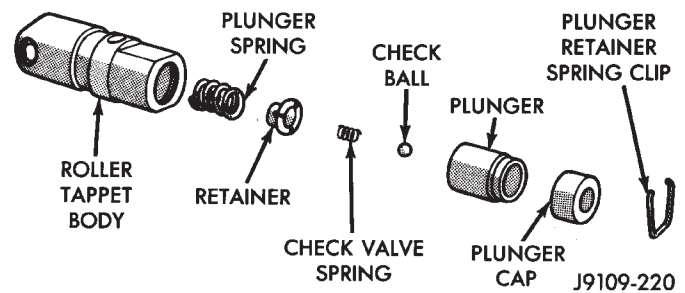

Fig. 27 Hydraulic Roller Tappet Assembly

(2) Replace tappets that are unfit for further service with new assemblies.

(3) If plunger shows signs of scoring or wear and valve is pitted, or if valve seat on end of plunger indicates any condition that would prevent valve from seating, install a new tappet assembly.

(4) Assemble tappets (Fig. 27).

INSTALLATION

(1) Lubricate tappets.

(2) Install tappets in their original positions.

(3) With roller tappets, install aligning yokes with (Fig. 25).

(4) Install yoke retainer and torque screws to 12 N•m (105 in. lbs.) (Fig. 25).

(5) Install cylinder heads. Refer to cylinder head installation of this section for procedure.

(6) Start and operate engine. Warm up to normal operating temperature.

CAUTION: To prevent damage to valve mechanism, engine must not be run above fast idle until all hydraulic tappets have filled with oil and have become quiet.

VALVE TIMING

(1) Remove front valve cover and all 6 spark plugs.

(2) Rotate engine until the #2 piston is at TDC of the compression stroke.

(3) Install a degree wheel on the crankshaft pulley.

(4) With proper adaptor, install a dial into #2 spark plug hole. Using the indicator find TDC on the compression stroke.

(5) Position the degree wheel to zero.

(6) Remove dial indicator from spark plug hole.

(7) Place a 5.08mm (.200 inch) spacer between the valve stem tip of #2 intake valve and rocker arm pad. Allow tappet to bleed down to give a solid tappet effect.

(8) Install a dial indicator so plunger contacts the #2 intake valve spring retainer as nearly perpendicular as possible. Zero the indicator.

(9) Rotate the engine clockwise until the intake valve has lifted .254mm (0.010 inch).

CAUTION: Do not turn crankshaft any further clockwise as intake valve might bottom and result in serious damage.

(10) Degree wheel should read 3 degrees BTDC to 4 degrees ATDC.

TIMING CHAIN COVER, OIL SEAL AND CHAIN

COVER

REMOVAL

- (1) Disconnect battery.
- (2) Drain cooling system. Refer to Cooling System Group 7 for procedure.
- (3) Support engine and remove right engine mount.
- (4) Raise vehicle on hoist. Drain engine oil.
- (5) Remove oil pan and oil pump pick-up. It may be necessary to remove transmission inspection cover.
- (6) Remove right wheel and inner splash shield.
- (7) Remove drive belt. Refer to Cooling System Group 7 for procedure.
- (8) Remove A/C compressor and set aside.
- (9) Remove A/C compressor mounting bracket.
- (10) Remove crankshaft pulley. (Fig. 1)
- (11) Remove idler pulley from engine bracket.
- (12) Remove engine bracket. (Fig. 2)
- (13) Remove cam sensor from chain case cover. (Fig. 3)
- (14) Remove chain case cover (Fig. 3)

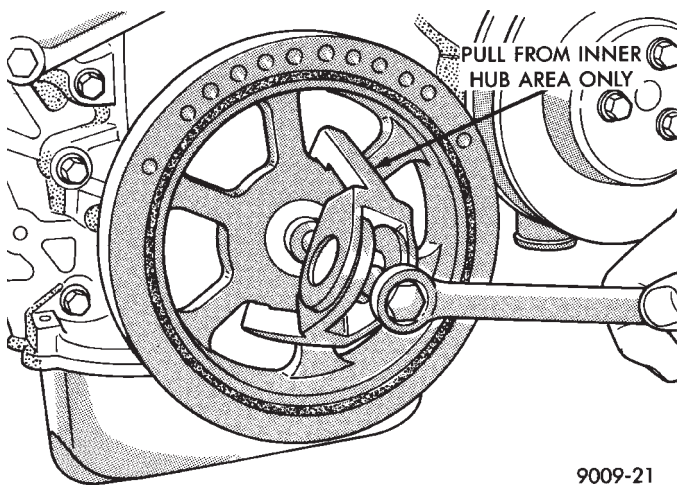

Fig. 1 Removing Crankshaft Pulley

MEASURING TIMING CHAIN FOR STRETCH

- (1) Place a scale next to timing chain so that any movement of chain may be measured.
- (2) Place a torque wrench and socket on camshaft sprocket attaching bolt and apply torque in direction of crankshaft rotation to take up slack; 41 N•m (30 ft. lb.) with cylinder head installed or 20 N•m (15 ft. lb.) with cylinder heads removed. **With a torque applied to the camshaft sprocket bolt, crankshaft should**

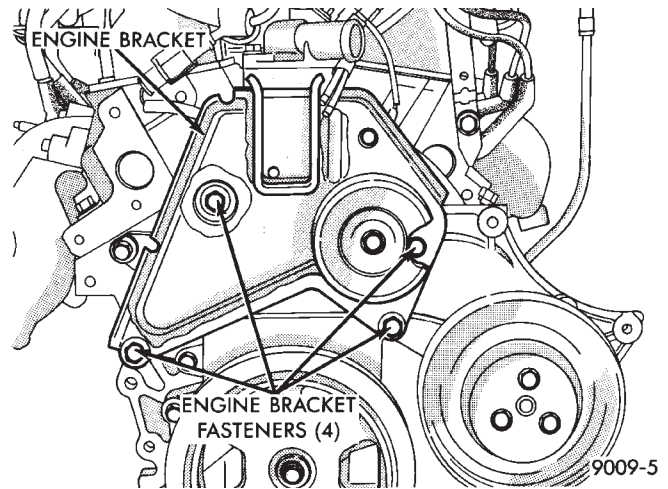

Fig. 2 Engine Bracket

not be permitted to move. It may be necessary to block crankshaft to prevent rotation.

(3) Holding a scale even, with dimension reading as shown (Fig. 4), along edge of chain links. Apply torque in the reverse direction to 41 N•m (30 ft. lbs.) with cylinder heads installed, or 20 N•m (15 ft. lbs.) with cylinder heads removed. Check amount of chain movement (Fig. 4).

(4) Install a new timing chain, if its movement exceeds 3.175mm (1/8 inch) (Fig. 4).

(5) If chain is not satisfactory, remove camshaft sprocket attaching bolt, and remove timing chain with camshaft sprocket.

(6) Using a suitable puller remove the crankshaft pulley. Be careful not to damage the crankshaft surface.

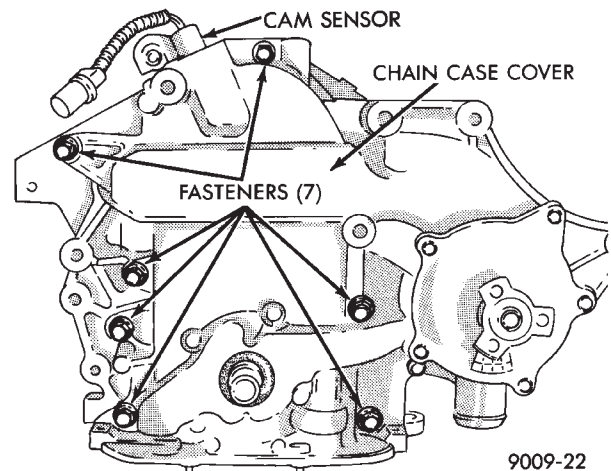

Fig. 3 Timing Chain Case Cover

(7) Position a new crankshaft sprocket on the shaft, install sprocket with suitable tool and mallet. Be sure sprocket is seated into position.

(8) Rotate crankshaft sprocket so the timing mark is to the 12 o'clock position.

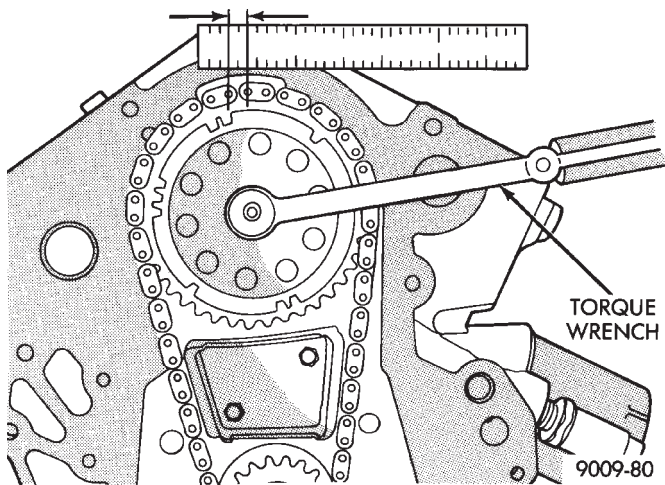

Fig. 4 Measuring Timing Chain Wear and Stretch

- (9) Place timing chain around camshaft sprocket and place the timing mark to the 6 o'clock position.
- (10) Place timing chain around crankshaft sprocket and install camshaft sprocket into position.
- (11) Using straight edge to check alignment of timing marks (Fig. 5).
- (12) Install camshaft bolt and washer. Tighten to 47 N•m (35 ft. lbs.).
- (13) Rotate crankshaft 2 revolutions. Timing marks should line up. If timing marks do not line up remove cam sprocket and realign.
- (14) Check camshaft endplay. With new thrust plate specification is .0127 to .304 mm (.005 to .012 inches). Old thrust plate specification is .31 mm (.012 inch.) maximum. If not within these limits install new thrust plate.
- (15) Install timing chain snubber. Tighten retaining screws to 12 N•m (105 in. lbs.). **These bolts are 20mm long for this model year, they should not be interchanged with previous year engines.**

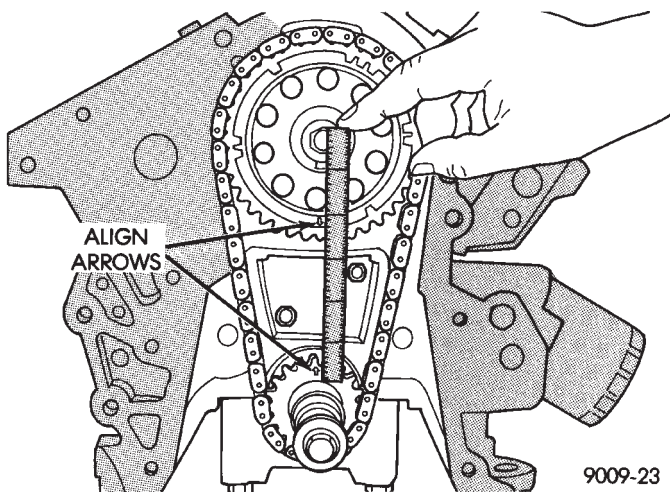

Fig. 5 Alignment of Timing Marks

INSTALLATION

- (1) Be sure mating surfaces of chain case cover and cylinder block are clean and free from burrs. Crankshaft oil seal must be removed to insure correct oil pump engagement.
- (2) Use a new cover gasket, O-rings. (Fig. 6).
- (3) Rotate crankshaft so that the oil pump drive flats are vertical.
- (4) Position oil pump inner rotor so the mating flats are in the same position as the crankshaft drive flats (Fig. 6).
- (5) Install cover onto crankshaft. Make sure the oil pump is engaged on the crankshaft correctly or severe damage may result.
- (6) Install chain case cover screws and torque to 27 N•m (20 ft. lbs.).
- (7) Install crankshaft oil seal (Fig. 7).
- (8) Install crankshaft pulley (Fig. 8).

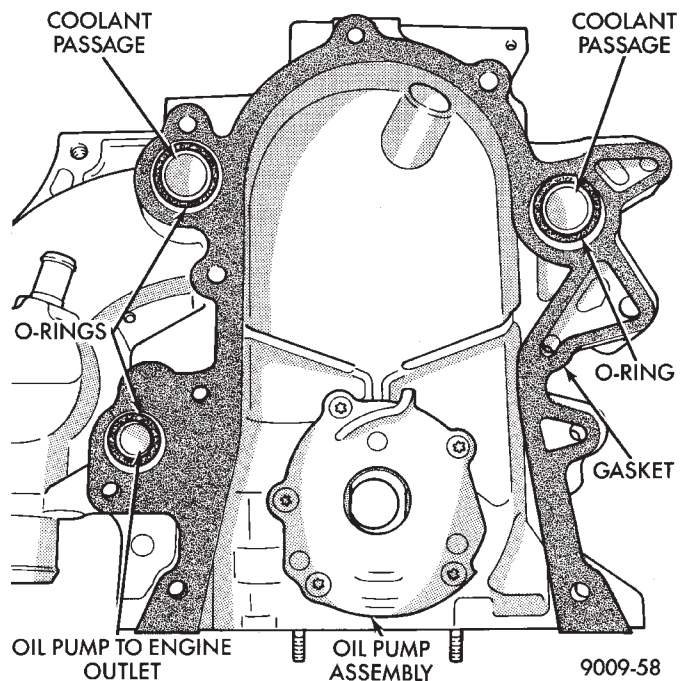

Fig. 6 Timing Chain Case Cover Gaskets and O-Rings

- (9) Install engine bracket (Fig. 2) torque screws to 54 N•m (40 ft. lbs.).
- (10) Install idler pulley on engine bracket.
- (11) Install cam sensor Refer to Ignition System Group 8D for installation procedure.
- (12) Install A/C compressor mounting bracket.
- (13) Install A/C compressor.
- (14) Install drive belt Refer to Cooling System Group 7 for installation procedure.
- (15) Install inner splash shield and wheel.
- (16) Install oil pump pick-up and oil pan and transmission inspection cover if removed.
- (17) Install engine mount.
- (18) Fill crankcase with oil to proper level.

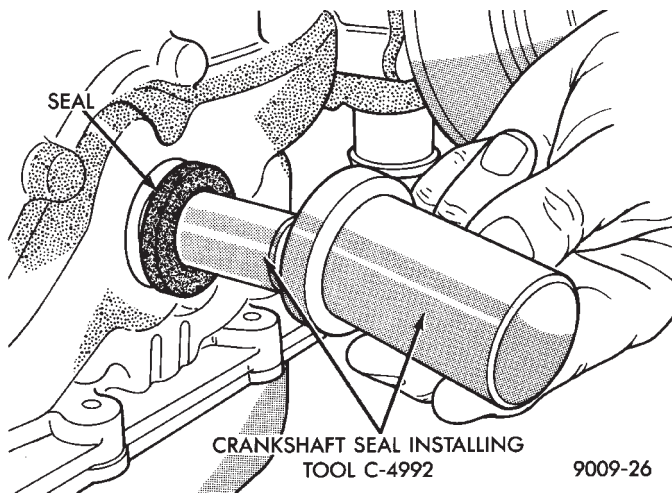

Fig. 7 Install Crankshaft Oil Seal

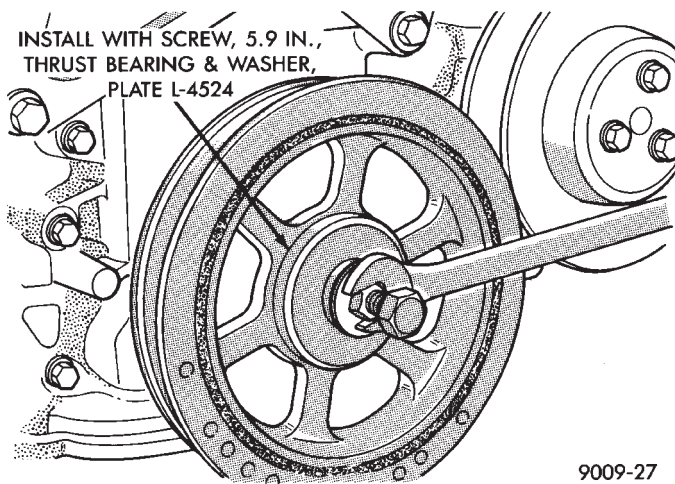

Fig. 8 Installing Crankshaft Pulley

- (19) Fill cooling system Refer to Cooling System Group 7 for procedure.
- (20) Connect battery.

TIMING CHAIN COVER EXTERNAL OIL SEAL

REMOVAL

- (1) Raise vehicle on hoist. Remove right wheel and inner splash shield.
- (2) Remove drive belt. (Refer to Cooling System Group 7) for procedure.
- (3) Remove crankshaft pulley (Fig. 1).
- (4) Using Tool C-4991 to remove oil seal (Fig. 9). Be careful not to damage that crankshaft seal surface of cover.

INSTALLATION

- (1) Install new seal by using Tool C-4992 (Fig. 7).
- (2) Place seal into opening with seal spring towards the inside of engine. Install seal until flush with cover.
- (3) Install crankshaft pulley using plate L-4524. Thrust Bearing/washer and 5.9 inch screw (Fig. 8).

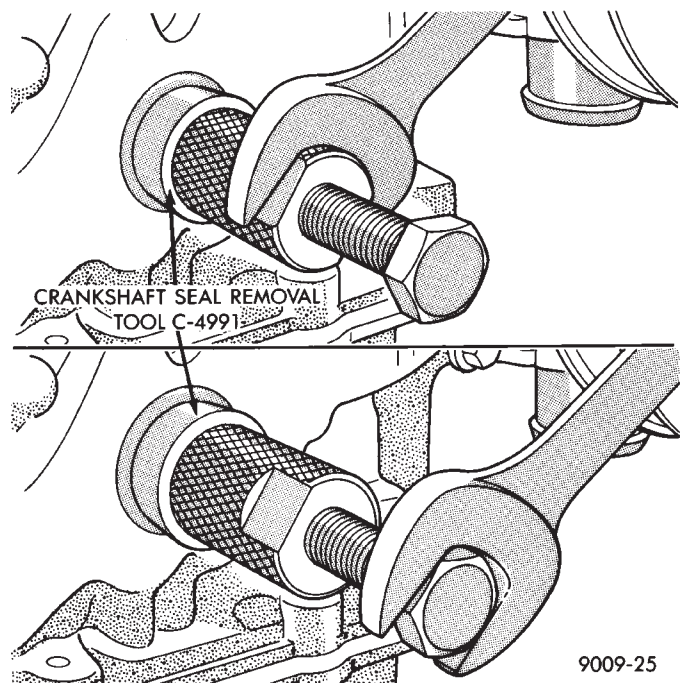

Fig. 9 Removing Crankshaft Oil Seal

- (4) Install drive belt (Refer to Cooling System Group 7) for installation procedure.
- (5) Install inner splash shield and wheel.

CAMSHAFT

REMOVAL—ENGINE REMOVED FROM VEHICLE

Remove intake manifold, cylinder head covers, cylinder heads, timing chain case cover and timing chain.

- (1) Remove rocker arm and shaft assemblies.
- (2) Remove push rods and tappets; identify so each part will be replaced in its original location.
- (3) Remove camshaft thrust plate (Fig. 10).
- (4) Install a long bolt into front of camshaft to facilitate removal of the camshaft; remove camshaft, being careful not to damage cam bearing with the cam lobes.

INSTALLATION

- (1) Lubricate camshaft lobes and camshaft bearing journals and insert the camshaft to within 2 inches of its final position in cylinder block.

Whenever an engine has been rebuilt and/or a new camshaft and/or new tappets have been installed, add one pint of Chrysler Crankcase Conditioner or equivalent to engine oil to aid in break in. The oil mixture should be left in engine for a minimum of 805km (500 miles) and drained at the next normal oil change.

- (2) Install camshaft thrust plate with two screws as shown in (Fig. 10). Tighten to 12 N•m (105 in. lbs.) torque.
- (3) Place both camshaft sprocket and crankshaft

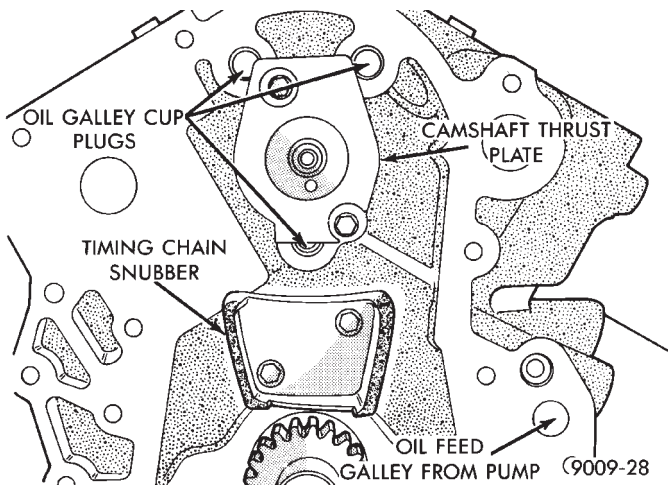

Fig. 10 Camshaft Thrust Plate

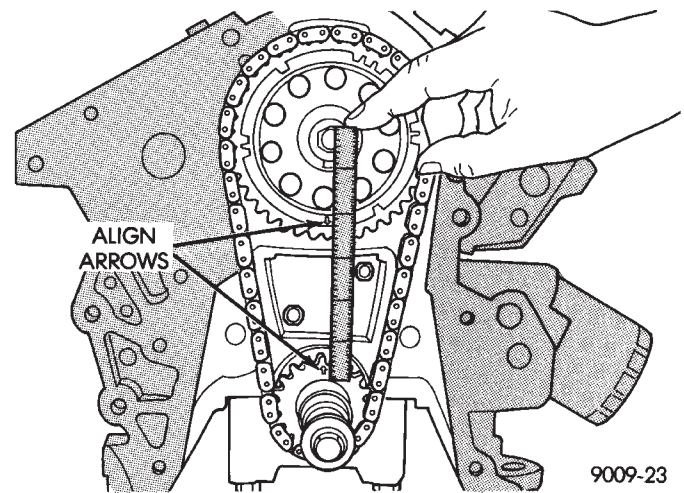

Fig. 12 Alignment of Timing Marks

CAMSHAFT BEARINGS—ENGINE REMOVED FROM VEHICLE

REMOVAL

- (1) With engine completely disassembled, drive out rear cam bearing core hole plug.
- (2) Install proper size adapters and horse shoe washers part of Tool C-3132-A at back of each bearing shell to be removed and drive out bearing shells (Fig. 13).

INSTALLATION

- (1) Install new camshaft bearings with Tool C-3132-A by sliding the new camshaft bearing shell over proper adapter.
- (2) Position rear bearing in the tool. Install horse-shoe lock and by reversing removal procedure, carefully drive bearing shell into place.
- (3) Install remaining bearings in the same manner. Bearings must be carefully aligned to bring oil holes into full register with oil passages from the main bearing. Number two bearing must index with the oil passage to the left cylinder head and Number three bearing must index with the oil passage to the right cylinder head. If the camshaft bearing shell oil holes are not in exact alignment, remove and reinstall them correctly. Install a new core hole plug at the rear of camshaft. **Be sure this plug does not leak.**

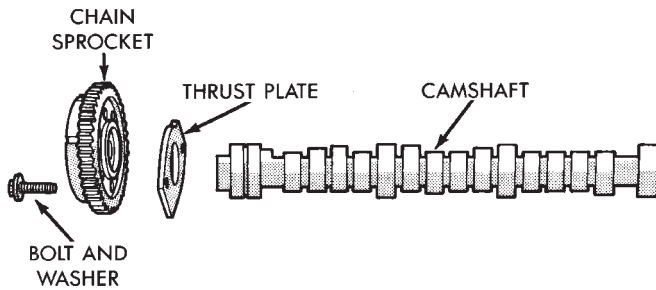

Fig. 11 Camshaft and Sprocket Assembly

sprocket on the bench with timing marks on exact imaginary center line through both camshaft and crankshaft bores.

- (4) Place timing chain around both sprockets.
- (5) Turn crankshaft and camshaft to line up with keyway location in crankshaft sprocket and in camshaft sprocket.
- (6) Lift sprockets and chain keep sprockets tight against the chain in position as described.
- (7) Slide both sprockets evenly over their respective shafts use a straightedge to check alignment of timing marks (Fig. 12).
- (8) Install the camshaft bolt. Tighten bolt to 54 N•m (40 ft. lbs.).
- (9) Rotate crankshaft 2 revolutions. Timing marks should line up. If timing marks do not line up, remove cam sprocket and realign.
- (10) Measure camshaft end play. End Play should measure .0127 to .304 mm (.005 to .012 inches.) .310 mm (.012 inch. Max.). If not within limits install a new thrust plate.
- (11) Each tappet reused must be installed in the same position from which it was removed. **When camshaft is replaced, all of the tappets must be replaced.**

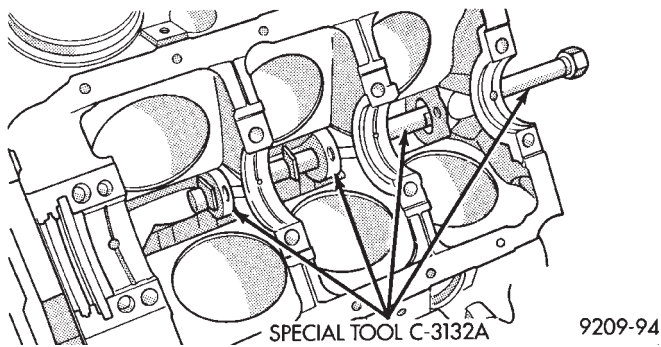

Fig. 13 Removed Installation of Camshaft Bearings with Tool C-3132A—Typical

ENGINE CORE OIL AND CAM PLUGS

REMOVAL

Using a blunt tool such as a drift and a hammer, strike the bottom edge of the cup plug. With the cup plug rotated, grasp firmly with pliers or other suitable tool and remove plug (Fig. 14).

CAUTION: Do not drive cup plug into the casting as restricted cooling can result and cause serious engine problems.

INSTALLATION

Thoroughly clean inside of cup plug hole in cylinder block or head. Be sure to remove old sealer. Lightly coat inside of cup plug hole with Loctite Stud N' Bearing Mount or equivalent. Make certain the new plug is cleaned of all oil or grease. Using proper drive plug, drive plug into hole so that the sharp edge of the plug is at least 0.5mm (.020 inch) inside the lead-in chamfer.

It is not necessary to wait for curing of the sealant. The cooling system can be refilled and the vehicle placed in service immediately.

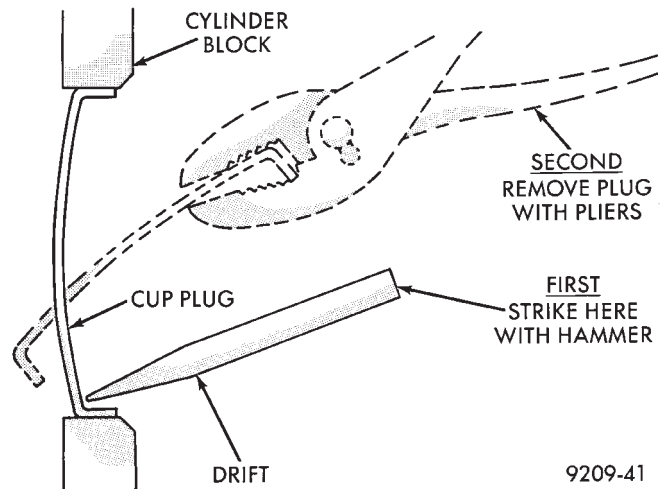
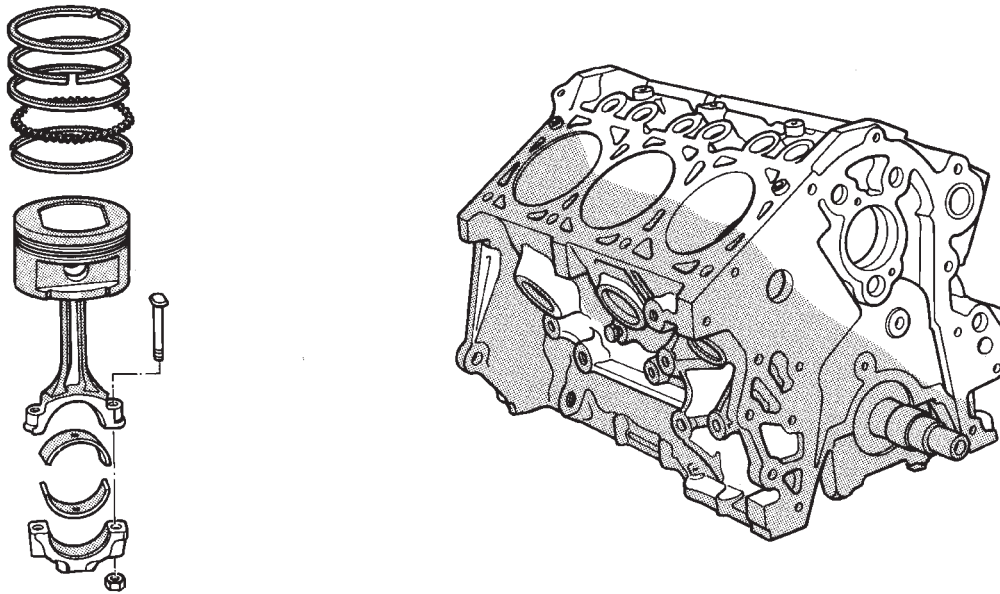

Fig. 14 Core Hole Plug Removal

CYLINDER BLOCK, PISTON AND CONNECTING ROD ASSEMBLY SERVICE



9009-73

Fig. 1 Cylinder Block, Piston and Connecting Rod Assembly

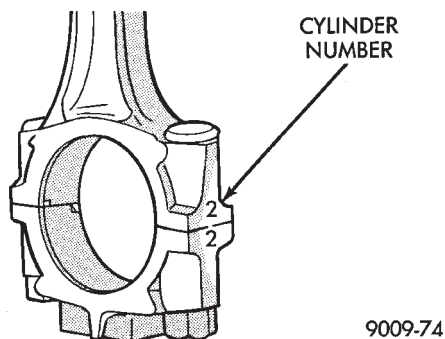

9009-74

Fig. 2 Identify Connecting Rod to Cylinder

CYLINDER BLOCK

PISTON—REMOVAL

(1) Remove top ridge of cylinder bores with a reliable ridge reamer before removing pistons from cylinder block. **Be sure to keep tops of pistons covered during this operation. Pistons and connecting rods must be removed from top of cylinder block. When removing piston and connecting rod assemblies from the engine, rotate crankshaft so that each connecting rod is centered in cylinder bore.**

(2) Inspect connecting rods and connecting rod caps for cylinder identification. Identify them if necessary. (Fig. 2)

(3) Remove connecting rod cap. Install connecting rod bolt protectors on connecting rod bolts (Fig. 3). Push each piston and rod assembly out of cylinder bore.

Be careful not to nick crankshaft journals.

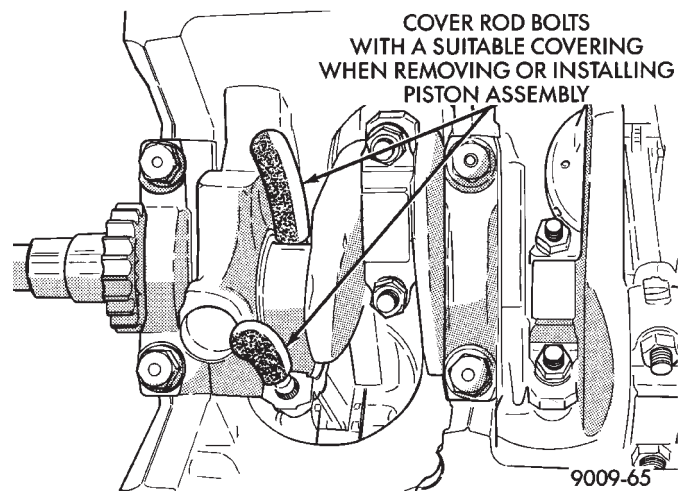

Fig. 3 Connecting Rod Protectors

(4) After removal, install bearing cap on the mating rod.

CLEANING AND INSPECTION

(1) Clean cylinder block thoroughly and check all core hole plugs for evidence of leaking.

(2) If new core plugs are installed, see Engine Core Oil and Cam Plugs.

(3) Examine block for cracks or fractures.

CYLINDER BORE INSPECTION

The cylinder walls should be checked for out-of-round and taper with Tool C-119 (Fig. 4). If the cylinder walls are badly scuffed or scored, the cylinder block should be rebored and honed, and new pistons

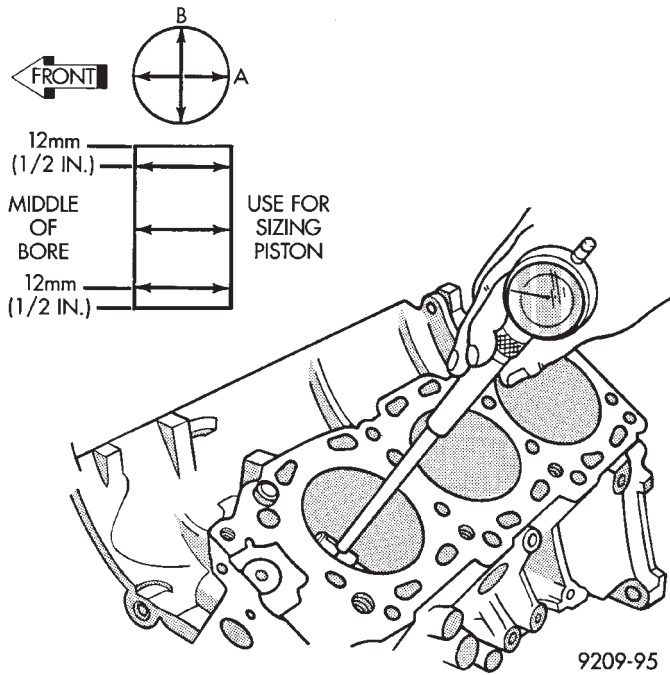

Fig. 4 Checking Cylinder Bore Size

and rings fitted. Whatever type of boring equipment is used, boring and honing operation should be closely coordinated with the fitting of pistons and rings in order that specified clearances may be maintained.

Refer to Honing Cylinder Bores outlined in the Standard Service Procedures for specification and procedures.

Measure the cylinder bore at three levels in directions A and B (Fig. 4). Top measurement should be 12mm (.50 inch) down and bottom measurement should be 12mm (.50 inch.) up from bottom of bore. Refer to (Fig. 5) for specifications.

FINISHED PISTONS

All pistons are machined to the same weight in grams, regardless of oversize, to maintain piston balance.

FITTING PISTONS

Piston and cylinder wall must be clean and dry. Piston diameter should be measured 90 degrees to piston pin at size location shown in (Fig. 6). Cylinder bores should be measured halfway down the cylinder bore and transverse to the engine crankshaft center line shown in (Fig. 4). Refer to (Fig. 5) for specifications.

Pistons and cylinder bores should be measured at normal room temperature, 70°F. (21°C).

PISTON PINS

The piston pin rotates in the piston only, and is retained by the press interference fit of the piston pin in the connecting rod. **The piston pin is not to be removed damage to the piston may result.**

| Engine | Standard Bore | Maximum Out-of-Round | Maximum Taper |
|---|---|-------------------------|------------------------|
| 3.3L | 92.993-93.007 mm 3.3661-3.6617 inch. | .076 mm (.003 inch.) | .51 mm (.002 inch.) |
| Standard Piston Size | | | |
| 3.3L | 92.950-92.968 mm (3.6594-3.6602 inch.) | | |
| Piston to Bore Clearance: .025-.057 mm (.0009 to .0022 inches.) | | | |
| Measurements taken at Piston Size location. | | | |
| Maximum Allowable Oversize Bore is .508 mm (.020 inches.) | | | |

9109-138

Fig. 5 Cylinder Bore and Piston Specifications

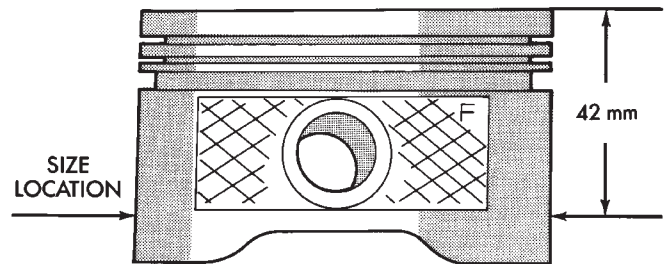

9009-67

Fig. 6 Piston Measurements

FITTING RINGS

(1) Wipe cylinder bore clean. Insert ring and push down with piston to ensure it is square in bore. The ring gap measurement must be made with the ring positioning at least 12mm (.50 inch) from bottom of cylinder bore. Check gap with feeler gauge (Fig. 7).

Refer to specifications (Fig. 8).

(2) Check piston ring to groove clearance: (Fig. 9). Refer to specification (Fig. 8).

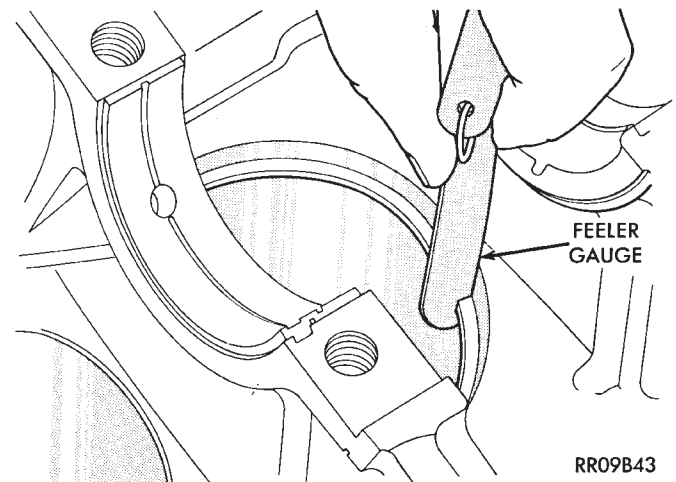

RR09B43

Fig. 7 Check Gap on Piston Rings

PISTON RINGS—INSTALLATION

(1) The No. 1 and No. 2 piston rings have a different cross section. Install rings with manufacturers I.D. mark facing up, to the top of the piston (Fig. 10).

| Ring Position | Ring Gap | Wear Limit |
|-------------------|--|-----------------------|
| Upper Ring | 0.30 to 0.55 mm (.012 to .022 in.) | 1.0 mm (.039 in.) |
| Intermediate Ring | 0.30 to 0.55 mm (.012 to .022 in.) | 1.0 mm (.039 in.) |
| Oil Control Ring | 0.25 to 1.00 mm (.010 to .039 in.) | 1.88 mm (.074 in.) |
| Ring Position | Groove Clearance | Maximum Clearance |
| Upper Ring | 0.030 to 0.085 mm (.001 to .0030 in.) | .10 mm (.004 in.) |
| Intermediate Ring | 0.030 to 0.095 mm (.001 to .0037 in.) | .10 mm (.004 in.) |
| Oil Control Ring | 0.014 to .266 mm (.0005 to .009 in.) | .266 mm (.009 in.) |

9109-48

Fig. 8 Piston Ring Specifications

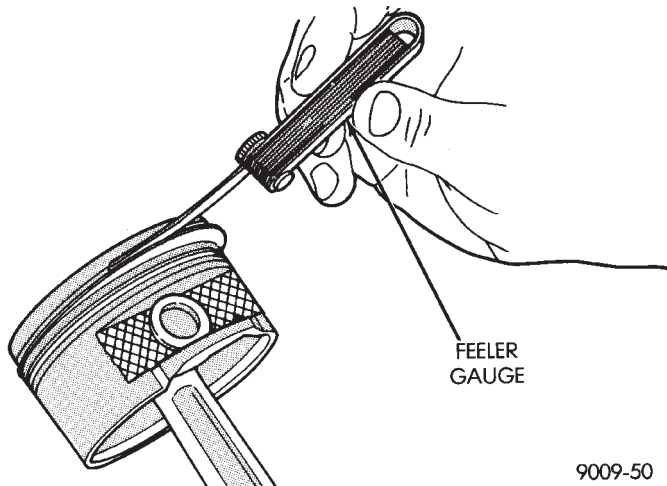

Fig. 9 Measuring Piston Ring Side Clearance

CAUTION: Install piston rings in the following order:

- (a) Oil ring expander.
- (b) Upper oil ring side rail.
- (c) Lower oil ring side rail.
- (d) No. 2 Intermediate piston ring.
- (e) No. 1 Upper piston ring.

(2) Install the side rail by placing one end between the piston ring groove and the expander. Hold end firmly and press down the portion to be installed until side rail is in position. **Do not use a piston ring expander.** (Fig. 11).

(3) Install upper side rail first and then the lower side rail.

(4) Install No. 2 piston ring and then No. 1 piston ring (Fig. 12).

(5) Position piston ring end gaps as shown in (Fig. 13).

(6) Position oil ring expander gap at least 45° from the side rail gaps but **not** on the piston pin center or on the thrust direction. Staggering ring gap is important for oil control.

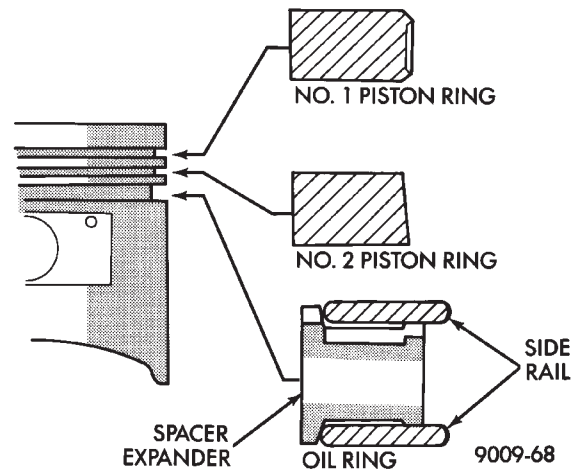

Fig. 10 Piston Ring Installation

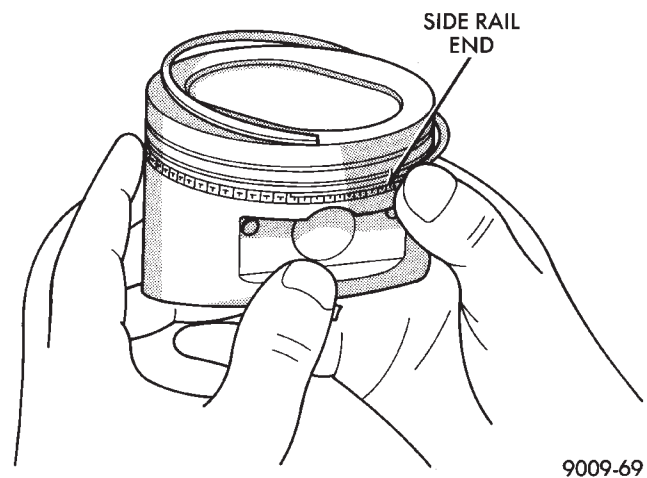

Fig. 11 Installing Side Rail

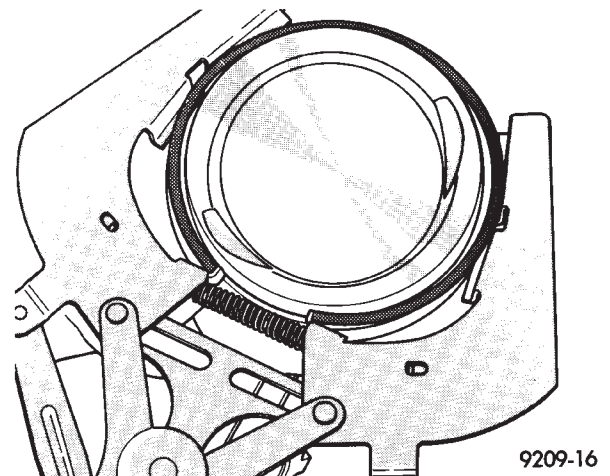

Fig. 12 Installing Upper and Intermediate Rings

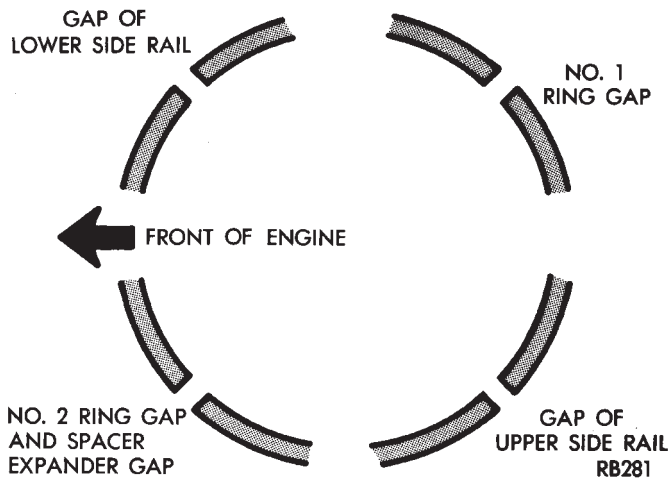

Fig. 13 Piston Ring End Gap Position

INSTALLING PISTON AND CONNECTING ROD ASSEMBLY

(1) Before installing pistons, and connecting rod assemblies into the bore, be sure that compression ring gaps are staggered so that neither is in line with oil ring gap.

(2) Before installing the ring compressor, make sure the oil ring expander ends are butted and the rail gaps located as shown in (Fig. 14).

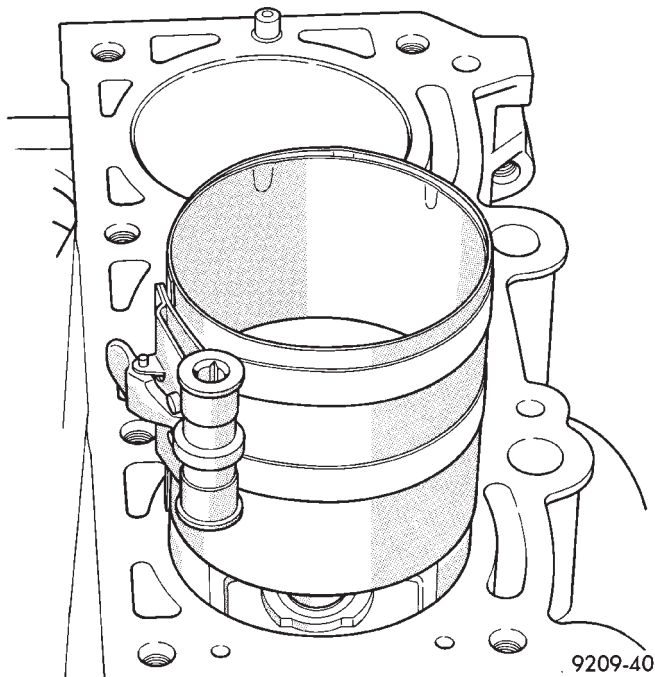

Fig. 14 Installing Piston

(3) Immerse the piston head and rings in clean engine oil, slide the ring compressor, over the piston and tighten with the special wrench. **Be sure position of rings does not change during this operation.**

(4) Install connecting rod bolt protectors on rod bolts. (Fig. 3)

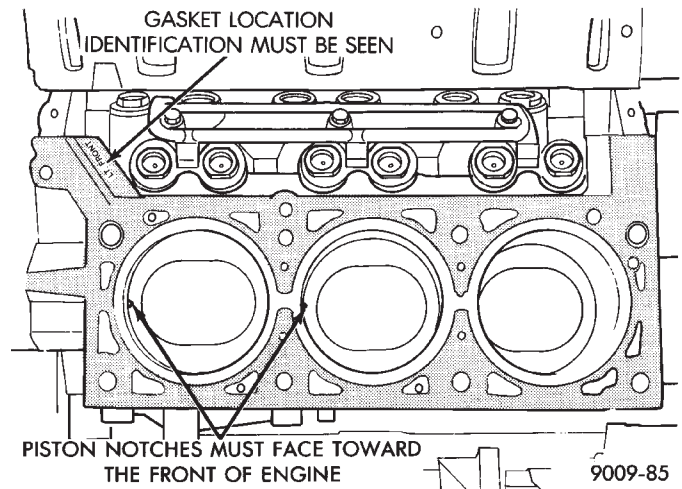

Fig. 15 Piston I.D. Notches

(5) Rotate crankshaft so that the connecting rod journal is on the center of the cylinder bore. Insert rod and piston into cylinder bore and guide rod over the crankshaft journal.

(6) Tap the piston down in cylinder bore, using a hammer handle. At the same time, guide connecting rod into position on connecting rod journal.

(7) The notch or groove on top of piston must be pointing toward front of engine (Fig. 15).

(8) Install rod caps. Install nuts on cleaned and oiled rod bolts and tighten nuts to 54 N•m (40 ft. lb.) Plus 1/4 turn.

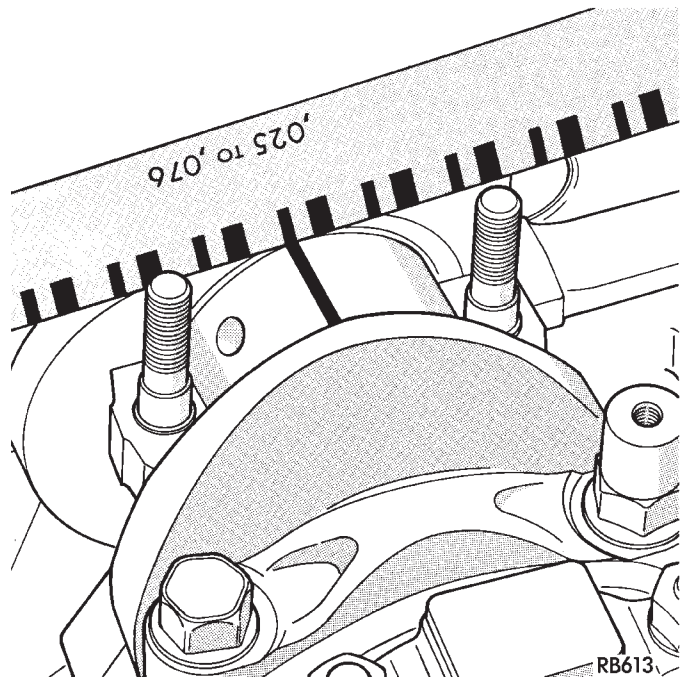

Fig. 16 Checking Connecting Rod Bearing Clearance

CONNECTING RODS

INSTALLATION OF CONNECTING ROD BEARINGS

Fit all rods on one bank until complete.

The bearing caps are not interchangeable and should be marked at removal to insure correct assembly.

The bearing shells must be installed with the tangs inserted into the machined grooves in the rods and caps. Install cap with the tangs on the same side as the rod.

Limits of taper or out-of-round on any crankshaft journals should be held to .025mm (.001 inch). Bearings are available in .025mm (.001 inch), .051mm (.002 inch), .076mm (.003 inch), .254mm (.010 inch) and .305mm (.012 inch) undersize. **Install the bearings in pairs. Do not use a new bearing half with an old bearing half. Do not file the rods or bearing caps.**

(1) Follow procedure specified in the Standard Service Procedure Section for Measuring Main Bearing Clearance and Connecting Rod Bearing Clearance (Fig. 16).

The rod bearing bolts should be examined before reuse. If the threads are necked down the bolts should be replaced (Fig. 19).

Necking can be checked by holding a scale or straight edge against the threads. If all the threads do not contact the scale the bolt should be replaced.

(2) Before installing the nuts the threads should be oiled with engine oil.

(3) Install nuts on each bolt finger tight then alternately torque each nut to assemble the cap properly.

(4) Tighten the nuts to 54 N•m PLUS 1/4 turn (40 ft. lbs. PLUS 1/4 turn).

(5) Using a feeler gauge, check connecting rod side clearance (Fig. 17). Refer to (Fig. 18) for specifications.

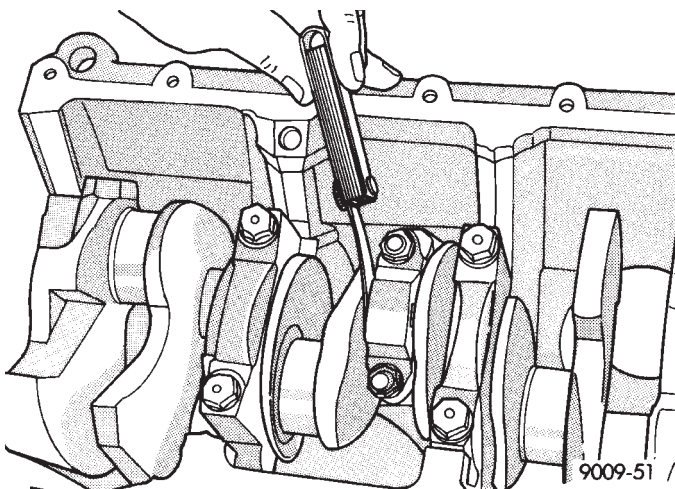

Fig. 17 Checking Connecting Rod Side Clearance

| Connecting Rod Bearing Clearance | |
|----------------------------------|---|
| New Part: | .019 to .087 mm (.0008 to .0034 in.) |
| Wear Limit: | .104 mm (.0041 in.) |
| Connecting Rod Side Clearance | |
| New Part: | 0.13 to 0.32 mm (.005 to .013 in.) |
| Wear Limit: | 0.38 mm (.015 in.) |

9109-49

Fig. 18 Connecting Rod Specifications

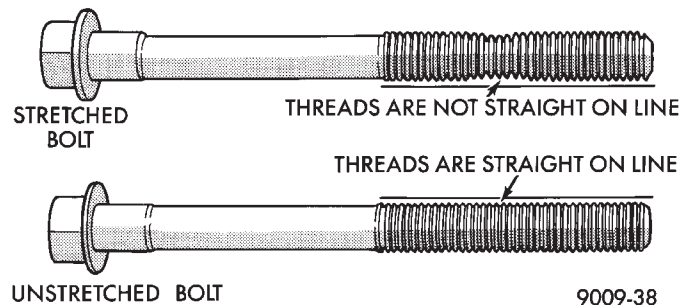

Fig. 19 Check for Stretched Rod Bolts

CRANKSHAFT SERVICE

CRANKSHAFT MAIN BEARINGS

Bearing caps are not interchangeable and should be marked at removal to insure correct assembly. (Fig. 1) Upper and lower bearing halves are NOT interchangeable. Lower main bearing halves of 1, 3 and 4 are interchangeable. Upper main bearing halves of 1, 3 and 4 are interchangeable.

CRANKSHAFT MAIN JOURNALS

The crankshaft journals should be checked for excessive wear, taper and scoring. (Fig. 6) Limits of taper or out-of-round on any crankshaft journals should be held to .025mm (.001 inch). Journal grinding should not exceed .305mm (.012 inch) under the standard journal diameter. Do NOT grind thrust faces of Number 2 main bearing. Do NOT nick crank pin or bearing fillets. After grinding, remove rough edges from crankshaft oil holes and clean out all passages.

CAUTION: With the nodular cast iron crankshafts used it is important that the final paper or cloth polish after any journal regrind be in the same direction as normal rotation in the engine.

Upper and lower Number 2 bearing halves are flanged to carry the crankshaft thrust loads and are NOT interchangeable with any other bearing halves in the engine (Fig. 2). All bearing cap bolts removed during service procedures are to be cleaned and oiled before installation. Bearing shells are available in

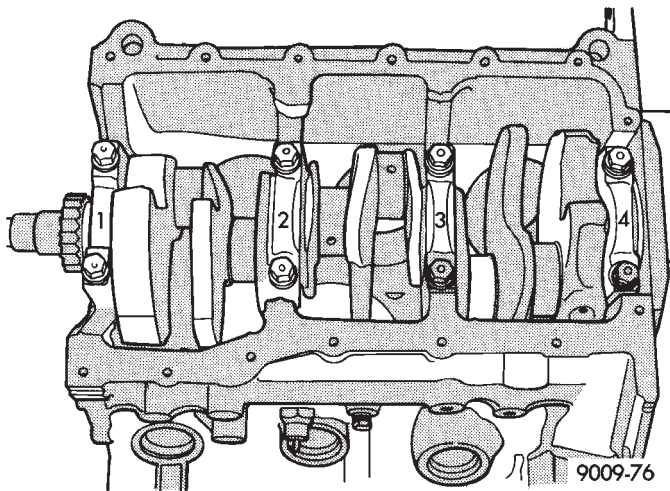

Fig. 1 Main Bearing Cap Identification

standard and the following undersizes: 0.025mm (.001 inch), .051mm (.002 inch), .076mm (.003 inch), .254mm (.010 inch), and .305mm (.012 inch). Never install an undersize bearing that will reduce clearance below specifications.

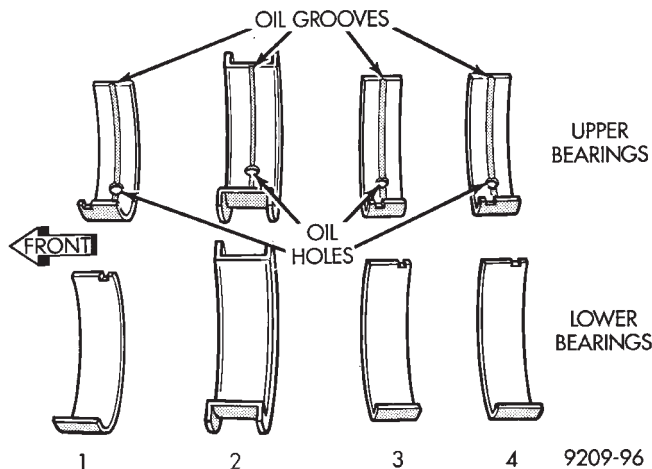

Fig. 2 Main Bearing Identification

REMOVAL

(1) Remove oil pan and identify bearing caps before removal.

(2) Remove bearing caps one at a time. Remove upper half of bearing by inserting Special Main Bearing Tool C-3059. (Fig. 3) into the oil hole of crankshaft.

(3) Slowly rotate crankshaft clockwise, forcing out upper half of bearing shell.

INSTALLATION

Only one main bearing should be selectively fitted while all other main bearing caps are properly tightened.

When installing a new upper bearing shell, slightly chamfer the sharp edges from the plain side.

(1) Start bearing in place, and insert Main Bearing Tool C-3059 into oil hole of crankshaft (Fig. 3).

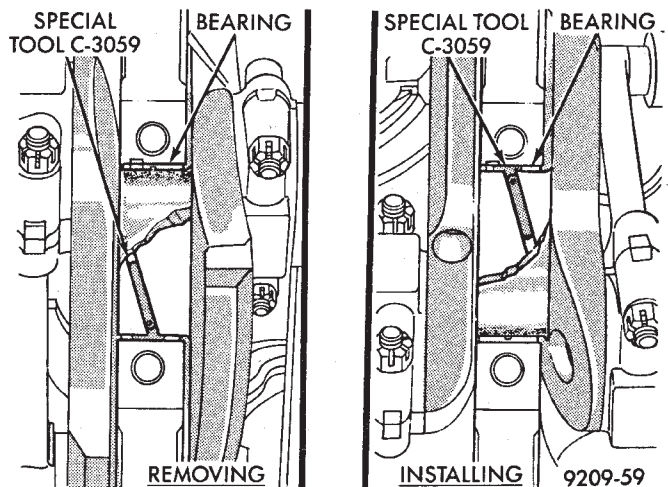

Fig. 3 Removing and Installing Upper Main Bearing With Special Tool C-3059

(2) Slowly rotate crankshaft counter-clockwise sliding the bearing into position. Remove Special Main Bearing Tool C-3059.

(3) Install each main cap and tighten bolts finger tight.

(4) Tighten number 1, 3 and 4 main cap bolts to 41 N•m + 1/4 Turn (30 ft. lbs.+ 1/4 Turn).

(5) Rotate the crankshaft until number 6 piston is at TDC.

(6) To ensure correct thrust bearing alignment the following procedure must be done:

(a) Move crankshaft all the way to the rear of its travel.

(b) Then, move crankshaft all the way to the front of its travel.

(c) Wedge a appropriate tool between the rear of the cylinder block and rear crankshaft counterweight. This will hold the crankshaft in it's most forward position.

(d) Tighten the #2 Thrust Bearing cap bolts to 41 N•m + 1/4 Turn (30 ft. lbs.+ 1/4 Turn). Remove the holding tool.

CHECKING CRANKSHAFT END PLAY

(1) Mount a dial indicator to front of engine, locating probe on nose of crankshaft (Fig. 4).

(2) Move crankshaft all the way to the rear of its travel.

(3) Zero the dial indicator.

(4) Move crankshaft all the way to the front and read the dial indicator. Refer to (Fig. 5) for specification.

CRANKSHAFT END PLAY CHECK—OPTIONAL

(1) Move crankshaft all the way to the rear of its travel using a screwdriver or other lever inserted between a main bearing cap and a crankshaft cheek us-

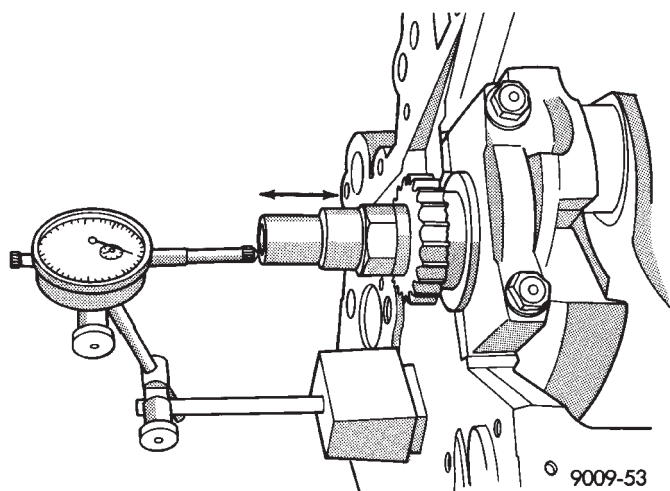

Fig. 4 Checking Crankshaft End Play

ing care not to damage any bearing surface. **Do not** loosen main bearing cap.

(2) Use a feeler gauge between number 2 thrust bearing and machined crankshaft surface to determine end play. Refer to (Fig. 5) for specification.

| | |
|--|---|
| Crankshaft End-Play | |
| New Part: .09 to 0.24 mm (.003 to .009 in.) | |
| Wear Limit: 0.37 mm (.015 in.) | |
| Main and Connecting Rod Bearing Clearance | |
| New Part: .019 to .077 mm (.0007 to .0030 in.) | |
| Wear Limit: .102 mm (.004 in.) | |
| Crankshaft Journal Sizes | |
| Crankshaft Main Bearing Journal | |
| ALL | Diameter |
| Standard | 64.00 ± 0.013 mm (2.519 ± .0005 in.) |
| Crankshaft Connecting Rod Journal | |
| ALL | Diameter |
| Standard | 58.00 ± 0.013 (2.283 ± .0005 in.) |

9109-123

Fig. 5 Crankshaft specification

CRANKSHAFT OIL CLEARANCE

(1) Measure the journal outside diameter as shown in (Fig. 6). Refer to specification (Fig. 5).

PLASTIGAGE (OIL CLEARANCE) MEASUREMENT

(1) Remove oil from journal and bearing shell.
 (2) Install crankshaft.
 (3) Cut plastigage to same length as width of the bearing and place it in parallel with the journal axis (Fig. 7).

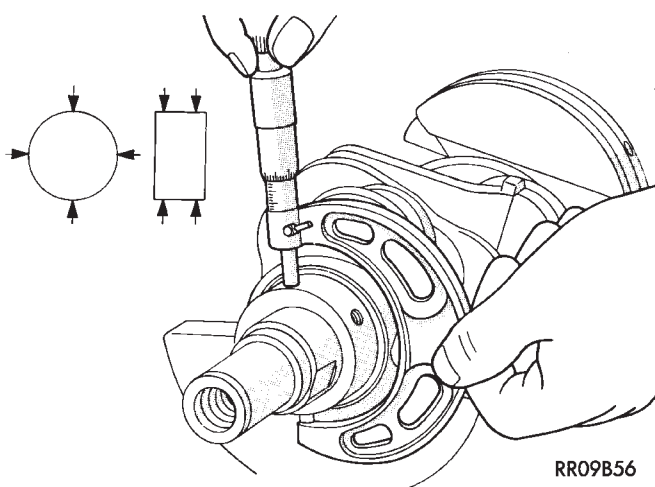

Fig. 6 Measure Crankshaft Journal O.D.

(4) Install the main bearing cap carefully and tighten the bolts to specified torque.

CAUTION: Do not rotate crankshaft or the plastigage will be smeared.

(5) Carefully remove the bearing cap and measure the width of the plastigage at the widest part using the scale on the plastigage package (Fig. 7). Refer to specification (Fig. 5) for proper clearances. If the clearance exceeds the specified limits. Replace the main bearing(s) and if necessary have the crankshaft machined to next undersize. Also see Measuring Main and Connecting Rod Bearing Clearance in Standard Service Procedures.

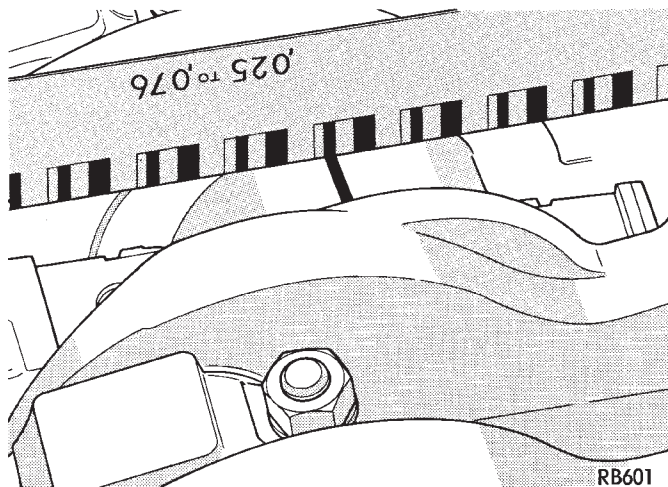

Fig. 7 Measuring Bearing Clearance with Plastigage

CAUTION: Do not rotate crankshaft or the Plastigage may be smeared.

CRANKSHAFT OIL SEALS SERVICE

REMOVAL

Pry out rear seal with screwdriver. Be careful not to nick or damage crankshaft flange seal surface or retainer bore (Fig. 8).

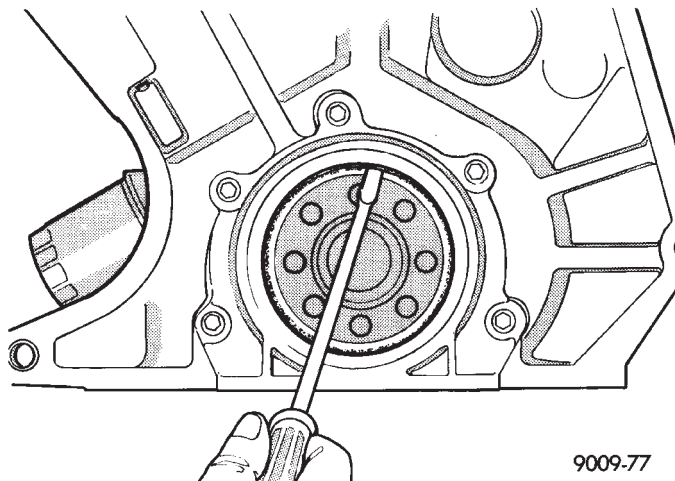

Fig. 8 Removing Rear Crankshaft Oil Seal

INSTALLATION

- (1) Place Special Seal Pilot Tool C-4681 on crankshaft (Fig. 9).
- (2) Lightly coat seal O.D. with Loctite Stud N' Bearing Mount or equivalent.
- (3) Place seal over Special Seal Pilot Tool C-4681 and tap in place with a plastic hammer.

REAR CRANKSHAFT SEAL RETAINER

When retainer removal is required, remove retainer clean engine block and retainer of old gasket. Make sure surfaces are clean and free of oil. Install new gasket and tighten screws to 12 N•m (105 in. lbs.).

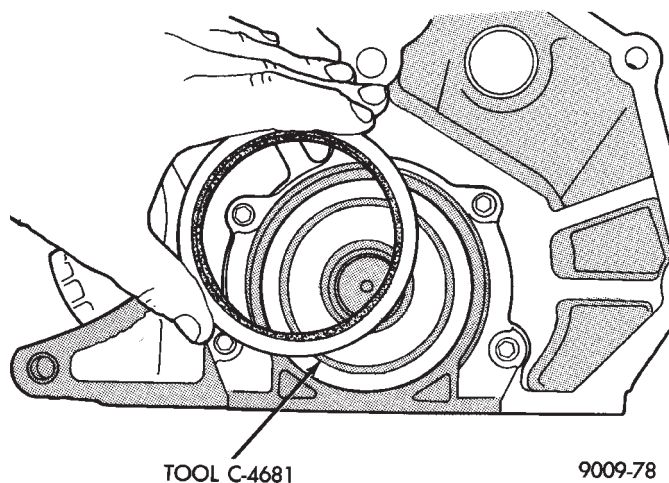
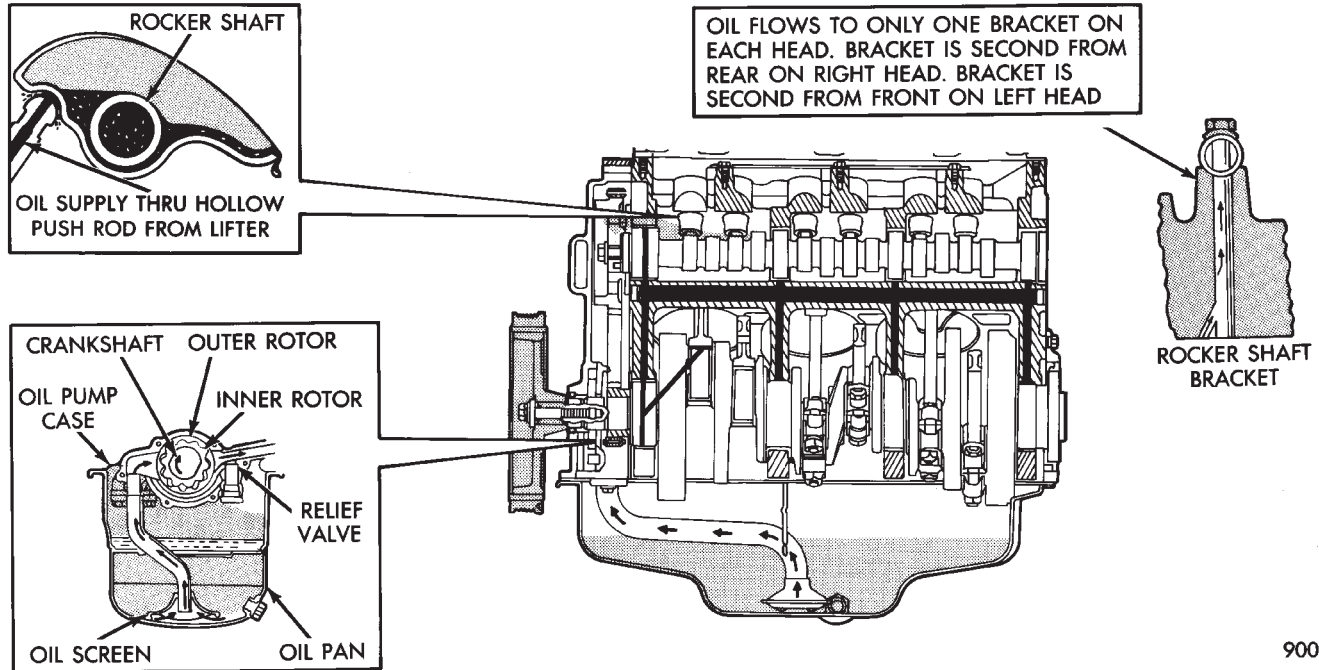

Fig. 9 Installing Rear Crankshaft Oil Seal

ENGINE LUBRICATION SYSTEM



9009-86

Fig. 1 Engine Oiling System

The lubrication system is a full flow filtration pressure feed type. Oil stored in the oil pan is taken in and discharged by an internal gear type oil pump directly coupled to the crankshaft. Its pressure is regulated by a relief valve located in the Chain Case Cover. The oil is pumped through an oil filter and feeds a main oil gallery. This oil gallery feeds oil under pressure to the main and rod bearings, camshaft bearings. Passages in the cylinder block feed oil to the hydraulic lifters and rocker shaft brackets which feeds the rocker arm pivots (Fig. 1).

OIL PAN SERVICE

REMOVAL

- (1) Disconnect negative battery cable, remove engine oil dipstick.
- (2) Raise vehicle. Drain engine oil.
- (3) Remove oil pan screws and remove oil pan.

CLEANING AND INSPECTION

- (1) Clean oil pan in solvent and wipe dry with a clean cloth. Clean all gasket material from mounting surfaces of pan and block.
- (2) Inspect oil drain plug and plug hole for stripped or damaged threads and repair as necessary. Install a new drain plug gasket. Tighten to 27 N•m (20 ft. lb.).
- (3) Inspect oil pan mounting flange for bends or distortion. Straighten flange if necessary.
- (4) Clean oil screen and pipe in clean solvent. Inspect condition of screen.

INSTALLATION

- (1) Install oil pick-up tube into Chain Case Cover tighten screw to 28 N•m (250 in. lbs.) (Fig. 2).
- (2) Apply a 1/8 inch bead of Mopar Silicone Rubber Adhesive Sealant or equivalent, at the parting line of the Chain Case Cover and the Rear Seal Retainer (Fig. 3).
- (3) Use a new pan gasket (Fig. 4).
- (4) Install pan and tighten screws to 23 N•m (200 in lb.).

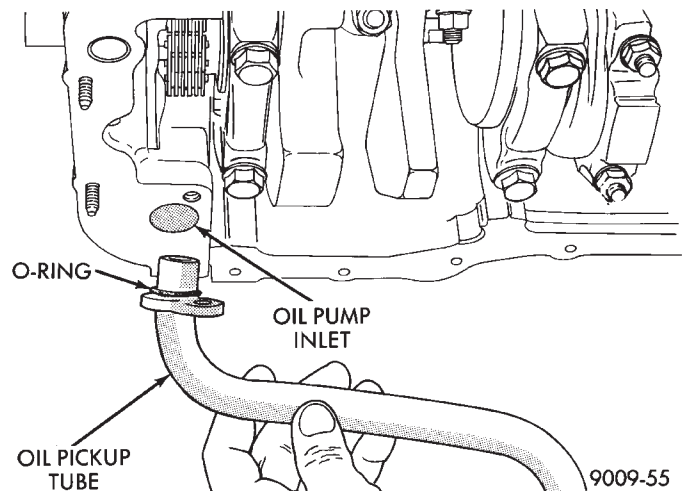

9009-55

Fig. 2 Oil Pump Pick-up Tube Service

- (5) Lower vehicle and install oil dipstick.
- (6) Connect negative battery cable.
- (7) Fill crankcase with oil to proper level.

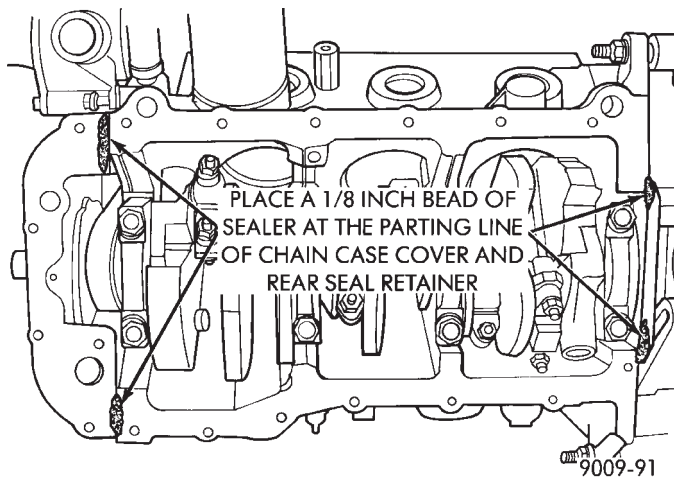

Fig. 3 Oil Pan Sealing

OIL PUMP SERVICE

It is necessary to remove the oil pan, oil pickup and chain case cover (CCC) to service the oil pump rotors. The oil pump pressure relief valve can be serviced by removing the oil pan and oil pickup tube. Refer to Timing Chain Cover Removal and Installation of this section for procedures.

DISASSEMBLY

(1) To remove the relief valve, proceed as follows:

(a) Drill a 3.175mm (1/8 inch) hole into the relief valve retainer cap and insert a self-threading sheet metal screw into cap.

(b) Clamp screw into a vise and while supporting chain case cover (CCC), remove cap by tapping CCC using a soft hammer. Discard retainer cap and remove spring and relief valve (Fig. 5).

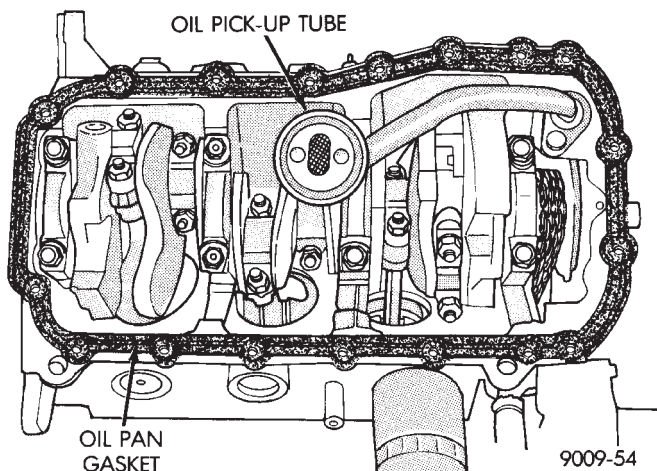

Fig. 4 Oil Pan Gasket Installation

- (2) Remove oil pump cover screws, and lift off cover.
- (3) Remove pump rotors.
- (4) Wash all parts in a suitable solvent and inspect carefully for damage or wear (Fig. 6).

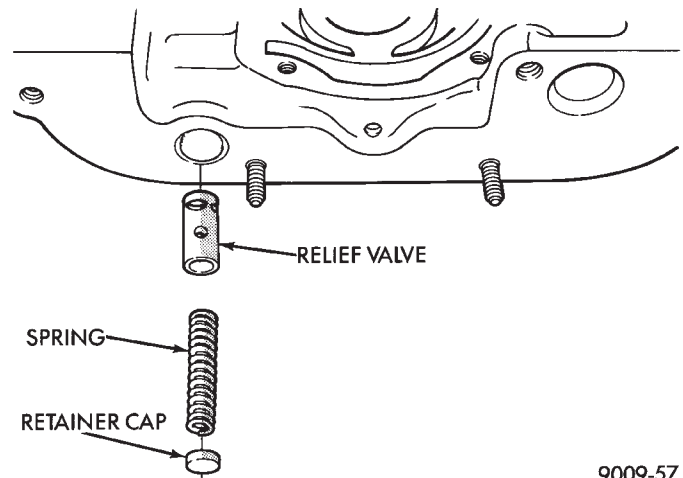

Fig. 5 Oil Pressure Relief Valve

INSPECTION AND REPAIR

(1) Clean all parts thoroughly. Mating surface of the chain case cover (CCC) should be smooth. Replace pump cover if scratched or grooved.

(2) Lay a straightedge across the pump cover surface (Fig. 7). If a .076mm (.003 inch) feeler gauge can be inserted between cover and straight edge, cover should be replaced.

(3) Measure thickness and diameter of outer rotor. If outer rotor thickness measures 7.36mm (.3005 inch) or less (Fig. 8), or if the diameter is 79.78mm (3.141 inches) or less, replace outer rotor.

(4) If inner rotor measures 7.64mm (.301 inch) or less replace inner rotor and shaft assembly (Fig. 9).

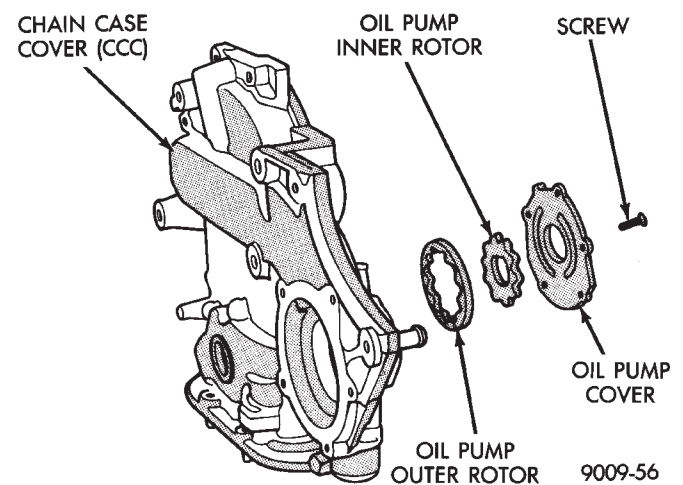
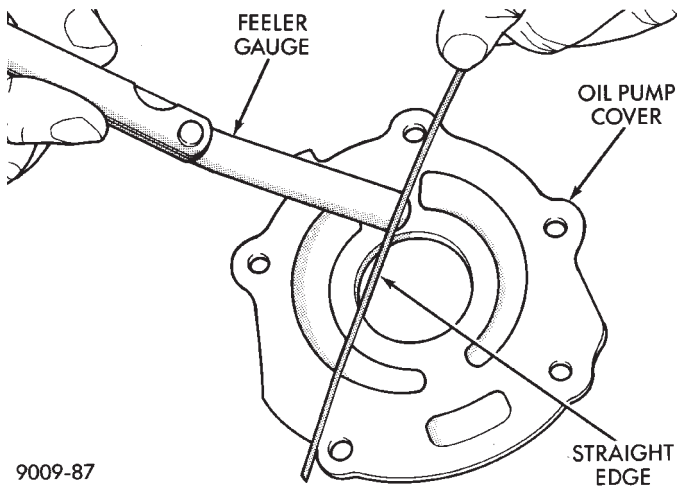

Fig. 6 Oil Pump

(5) Slide outer rotor into CCC, press to one side with fingers and measure clearance between rotor and CCC (Fig. 10). If measurement is 56mm (.022 inch) or more, replace CCC only if outer rotor is in spec.

(6) Install inner rotor into CCC. If clearance between inner and outer rotors (Fig. 11) is .203mm (.008 inch) or more, replace both rotors.



9009-87

Fig. 7 Checking Oil Pump Cover Flatness

(7) Place a straightedge across the face of the CCC, between bolt holes. If a feeler gauge of .102mm (.004 inch) or more can be inserted between rotors and the straightedge, replace pump assembly (Fig. 12). **ONLY** if rotors are in specs.

(8) Inspect oil pressure relief valve plunger for scoring and free operation in its bore. Small marks may be removed with 400-grit wet or dry sandpaper.

(9) The relief valve spring has a free length of approximately 49.5mm (1.95 inch) and should test between 19.5 and 20.5 pounds when compressed to 34mm (1-11/32 inches). Replace spring that fails to meet specifications (Fig. 5).

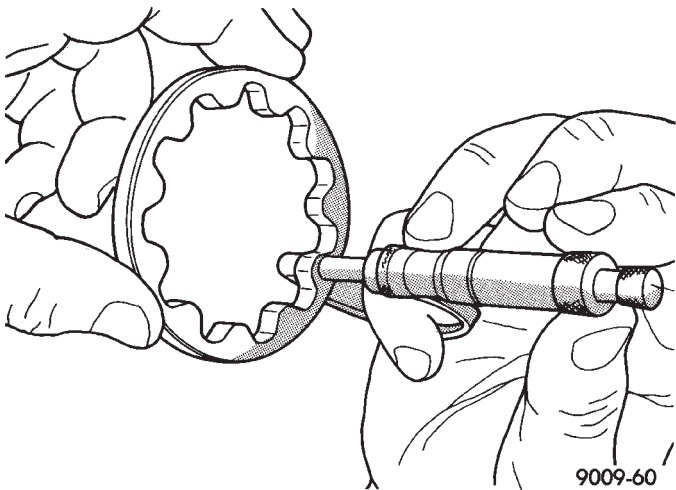
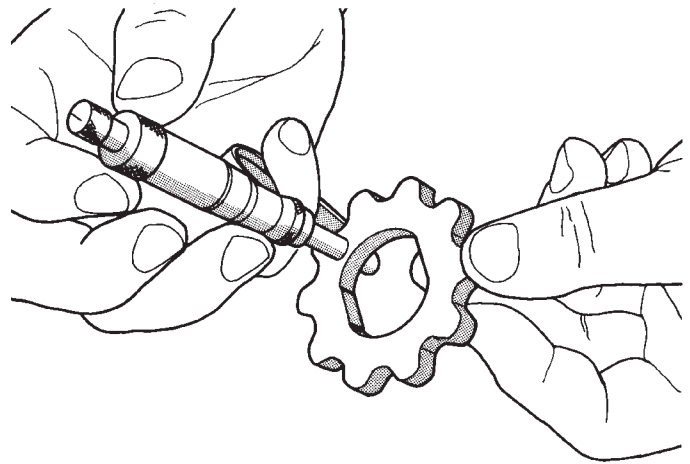

Fig. 8 Measuring Outer Rotor Thickness

(10) If oil pressure is low and pump is within specifications, inspect for worn engine bearings or other reasons for oil pressure loss.

OIL PUMP ASSEMBLY AND INSTALLATION

- (1) Assemble pump, using new parts as required.
- (2) Tighten cover screws to 12 N•m (105 in. lbs.).
- (3) Prime oil pump before installation by filling rotor cavity with engine oil.



9009-61

Fig. 9 Measuring Inner Rotor Thickness

(4) Install chain case cover slowly refer to Timing Chain Cover Installation of this section.

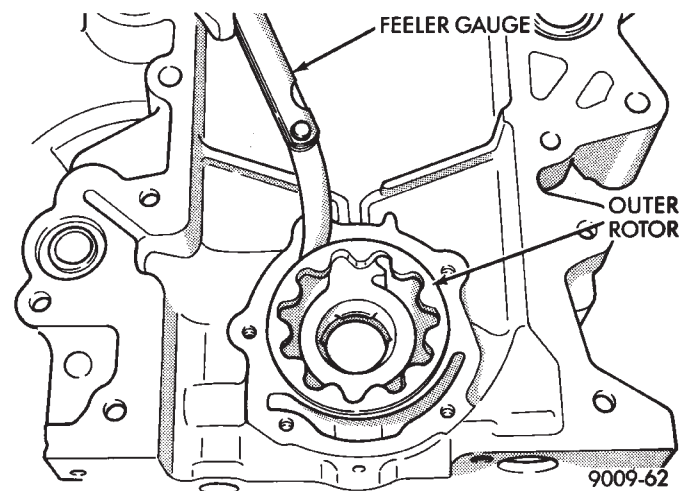

Fig. 10 Measuring Outer Rotor Clearance in Housing

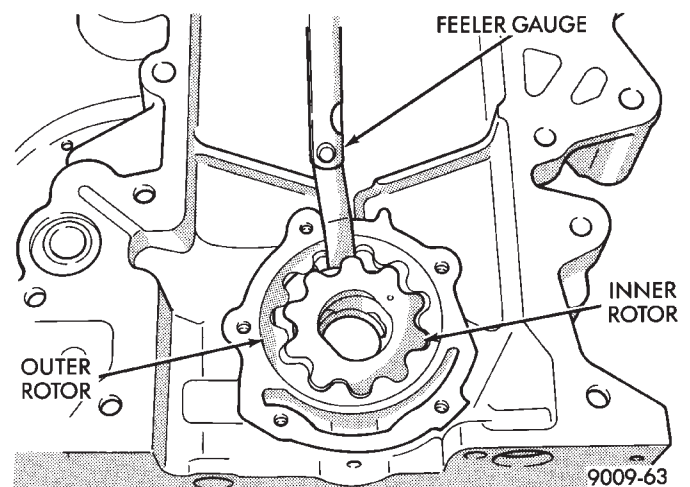

Fig. 11 Measuring Clearance Between Rotors

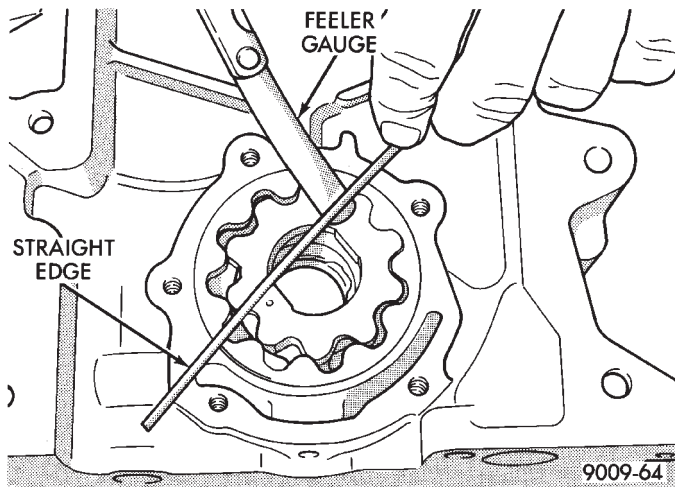

Fig. 12 Measuring Clearance Over Rotors

CHECKING ENGINE OIL PRESSURE

Check oil pressure using gauge at oil pressure switch location. Oil pressure should be 34.47 kPa (5 psi.) at idle or 205 to 551 kPa (30 to 80 psi.) at 3000 RPM.

(1) Remove pressure sending unit and install oil pressure gauge (Fig. 13).

CAUTION: If oil pressure is 0 at idle, Do Not Run engine at 3000 RPM.

(2) Warm engine at high idle until thermostat opens.

OIL FILTER

When servicing oil filter avoid deforming the filter can by installing the remove/install tool band strap against the can to base lockseam. The lockseam joining the can to the base is reinforced by the base plate.

(1) Using Tool C-4065, unscrew filter from base and discard (Fig. 14).

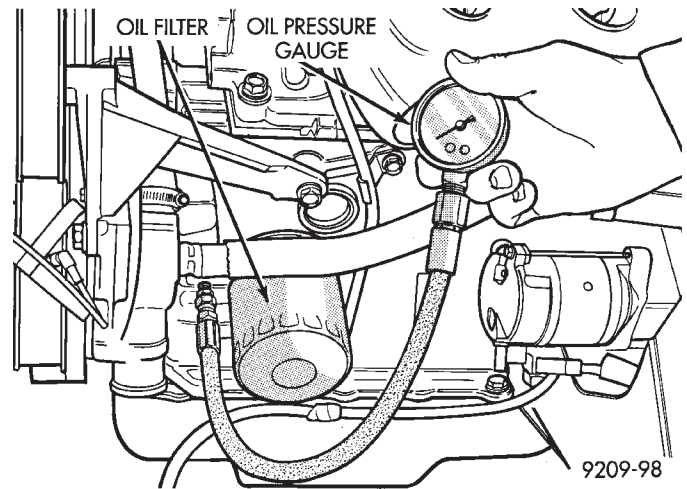

Fig. 13 Checking Oil Pump Pressure

(2) Wipe base clean, then inspect gasket contact surface.

(3) Lubricate gasket of new filter with clean engine oil.

(4) Install and tighten filter to 20 N•m (15 ft. lbs.) torque after gasket contacts base. Use filter wrench if necessary.

(5) Start engine and check for leaks.

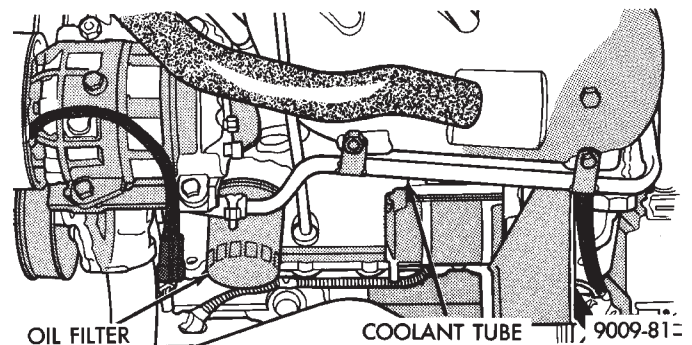

Fig. 14 Oil Filter



ENGINE SPECIFICATIONS

| | |
|---|-------------------------------|
| Type | 60° V-6 Engine |
| Bore | 93.0 mm (3.661 inches) |
| Stroke | 81.0 mm (3.188 inches) |
| Compression Ratio | 8.9:1 |
| Displacement | 3.3 Liters (201 cubic inches) |
| Brake Horsepower | 147 @4800 RPM |
| Torque | 185 lbs.-ft. @3600 RPM |
| Firing Order | 1-2-3-4-5-6 |
| Minimum Compression Pressure, see "Engine Performance" in Standard Service Procedures | 689.5 kPa (100 psi) |
| Maximum Variation Between Cylinders | 25% |

Cylinder Number (Front to Rear)

| | |
|------------|---------|
| Front Bank | 2, 4, 6 |
| Rear Bank | 1, 3, 5 |

Cylinder Block

| | |
|---|-------------------------|
| Cylinder Bore (Standard) | 93.0 mm (3.661 inches) |
| Cylinder Bore Out-of-Round (Maximum Allowable Before Reconditioning) | 0.076 mm (0.003 inch) |
| Cylinder Bore Taper (Maximum Allowable Before Reconditioning) | 0.051 mm (0.002 inch) |
| Reconditioning Working Limits (For Taper and Out-of-Round) | 0.001 inch |
| Tappet Bore Diameter | 0.9051 inch–0.9059 inch |

Pistons

| | |
|----------------------------|---------------------------------------|
| Type Material | Aluminum Alloy Tin Coated |
| Clearance at Size Location | 0.025–0.057 mm (0.001 to 0.0022 inch) |
| Weight (Std. Only) | 381±5 gms |
| Pistons For Service | STD. |

Piston Pins

| | |
|--|-------------------------------------|
| Type | Press Fit in Rod |
| Diameter | 22.88 mm (0.9009–0.9007 inch) |
| Length | 67.25–67.75 mm (2.648–2.667 inches) |
| Clearance in Piston (Light Thumb Push @70°F) | 0.006–0.019 mm (0.0002–0.0007 inch) |
| Clearance in Rod | (Interference) |

Piston Rings

| | |
|----------------------------|-------------------------------------|
| Number of Rings Per Piston | 3 |
| Compression | 2 |
| Oil | 1 |
| Oil Ring Type | 3-Piece, Steel Rail, Chrome-Face |
| Ring Width | |
| Compression | 1.46–1.5 mm (0.0575–0.0591 inch) |
| Oil—Steel Rails | 0.510 mm (0.0201 inch) |
| Ring Gap | |
| Compression | 0.300–0.550 mm (0.0118–0.0217 inch) |
| Oil—Steel Rails | 0.250–1.00 mm (0.0098–0.0394 inch) |
| Ring Side Clearance | |
| Compression | 0.030–0.095 mm (0.0012–0.0037 inch) |
| Oil—Steel Rails | 0.014–0.226 mm (0.0005–0.0089 inch) |
| Service Rings | |
| Ring Gap | |
| Compression | 0.300–0.550 mm (0.0018–0.0217 inch) |
| Oil—Steel Rails | 0.250–1.00 mm (0.0098–0.0394 inch) |
| Ring Side Clearance | |
| Compression | 0.030–0.095 mm (0.0012–0.0037 inch) |
| Oil—Steel Rails | 0.014–0.226 mm (0.0005–0.0089 inch) |

ENGINE SPECIFICATIONS (CONT.)

CONNECTING RODS

Side Clearance 0.127–0.381mm (0.005–0.015 inch)

CONNECTING ROD BEARINGS

Type Aluminum Lead (Bi-Metal)
 Clearance Desired 0.019–0.076mm (0.00075–0.003 inch.)
 Maximum Allowable 0.076mm (0.003 inch.)
 Bearings for Service Std., 0.025mm (0.001), 0.051mm (0.002),
 0.076mm (0.003), 0.254mm (0.010),
 0.305 mm (0.012 inches.)

CRANKSHAFT

Type Cast Nodular Iron
 Bearings Aluminum Lead (Bi-Metal)
 Thrust Taken By No. 2 Main Bearing
 End Play 0.076–0.228mm (0.003–0.009 inch.)
 Maximum Allowable 0.38mm (0.015 inch.)
 Diametral Clearance Desired #1, 2, 3 and 4 0.019–0.050mm (0.0007–0.0022 inch.)
 Maximum Diametral Clearance #1, 2, 3 and 4 0.055mm (0.0022 inch.)

MAIN BEARING JOURNALS

Diameter 64mm (2.519 inch.)
 Maximum Allowable Out-of-Round and/or Taper 0.025mm (0.001 inch.)
 Bearings for Service Std., 0.025mm (0.001), 0.051mm (0.002),
 0.076mm (0.003), 0.254mm (0.010),
 0.305mm (0.012 inches.)

CONNECTING ROD JOURNALS

Diameter 58mm (2.283 inch.)
 Maximum Allowable Out-of-Round and/or Taper 0.025mm (0.001 inch.)

CAMSHAFT

Drive Chain
 Bearings Steel Backed Babbitt
 Number 4
 Diametral Clearance 0.025–0.101mm (0.001–0.004 inch.)
 Maximum Allowable Before Reconditioning 0.127mm (0.005 inch.)
 Thrust Taken By Thrust Plate
 End Play 0.127–0.304mm (0.005–0.012 inch.)
 Maximum Allowable 0.304mm (0.012 inch.)

CAMSHAFT JOURNALS

Diameter
 No. 1 50.724–50.755mm (1.997–1.999 inch.)
 No. 2 50.317–50.368mm (1.980–1.982 inch.)
 No. 3 49.936–49.987mm (1.965–1.967 inch.)
 No. 4 49.530–49.581mm (1.949–1.952 inch.)

ENGINE SPECIFICATIONS (CONT.)

Camshaft Bearings

| | |
|-------------|-------------------------------------|
| Diameter | |
| No. 1 | 50.80–50.82 mm (2.000–2.001 inches) |
| No. 2 | 50.39–50.41 mm (1.984–1.985 inches) |
| No. 3 | 49.60–49.63 mm (1.953–1.954 inches) |
| No. 4 | 49.53–49.58 mm (1.950–1.951 inches) |

Valve Timing

| | |
|------------------------------|------|
| Intake Opens (BTC) | 0° |
| Intake Closes (ABC) | 60° |
| Exhaust Opens (BBC) | 48° |
| Exhaust Closes (ATC) | 12° |
| Valve Overlap | 12° |
| Intake Valve Duration | 240° |
| Exhaust Valve Duration | 240° |

Timing Chain

| | |
|-----------------------|-----------|
| Number of Links | 64 |
| Pitch | .375 inch |
| Width | .750 inch |

Tappets

| | |
|---------------------------------|--|
| Type | Roller Hydraulic |
| Body Diameter | 22.94–22.96 mm (0.9035–0.9040 inch) |
| Clearance to Block | 0.027–0.060 mm (0.0011–0.0024 inch) |
| Service Tappets Available | Std., 0.025 mm (0.001), 0.20 mm (0.008), 0.762 mm (0.030 inches) |

Cylinder Head

| | |
|---|---------------------------------|
| Valve Seat Run-Out (Maximum) | 0.760 mm (0.003 inch) |
| Intake Valve Seat Angle | 45–45-1/2° |
| Seat Width (Finished) | 1.75–2.25 mm (0.069–0.088 inch) |
| Exhaust Valve Seat Angle | 45–45-1/2° |
| Seat Width (Finished) | 1.50–2.00 mm (0.057–0.078 inch) |
| Cylinder Head Gasket (Thickness Compressed) | 1.78 mm (0.070 inch) |

Valve Guides

| | |
|---------------------------|------------------------------------|
| Type | Powdered Metal Inserts |
| Guide Bore Diameter | 7.795–8.000 mm (0.313–0.3149 inch) |

Valves—(Intake)

| | |
|--|---|
| Head Diameter | 45.5 mm (1.79 inches) |
| Length Overall (New) | 125.385–126.025 mm (4.936–4.961 inches) |
| Stem Diameter (Standard) | 7.935–7.953 mm (0.312–0.313 inch) |
| Stem to Guide Clearance | 0.025–0.095 mm (0.001–0.003 inch) |
| Maximum Allowable (By Rocking Method) | 0.247 mm (0.010 inch) |
| Face Angle | 44-1/2° |
| Valves for Service (Oversized Stem Diameter) | Std., 0.015 mm (0.005), 0.40 mm (0.015), 0.80 mm (0.030 inches) |
| Lift (Zero Lash) | 10.16 mm (0.400 inch) |
| Minimum Valve Length After Grinding Tip | 124.892 (4.916 inches) |

ENGINE SPECIFICATIONS (CONT.)

VALVES (EXHAUST)

| | |
|---|---|
| Head Diameter | 37.5mm (1.476 inch.) |
| Length Overall (New) | 126.095–126.645mm (4.964–4.986 inch.) |
| Stem Diameter (Standard) | 7.906–7.924mm (0.3112–0.3119 inch.) |
| Stem to Guide Clearance | 0.051–0.175mm (0.002–0.006 inch.) |
| Maximum Allowable by Rocking Method | 0.414mm (0.016 inch.) |
| Face Angle | 44-1/2° |
| Valves for Service (Oversize Stem Diameter) | Std., 0.015mm (0.005), 0.40mm (0.015), 0.80mm (0.030 inches.) |
| Lift (Zero Lash) | 10.16mm (0.400 inch.) |
| Minimum Valve Length After Grinding Tip | 125.512mm (4.941 inch.) |

ENGINE VALVE SPRINGS

Intake/Exhaust

| | |
|--|-------------------------------------|
| Number | 12 |
| Free Length (Approx.) | 48.5mm (1.909 inch.) |
| Wire Diameter | 4.75mm (0.187 inch.) |
| Number of coils | 6.8 |
| Load When Compressed to— Valve Closed | 58–63 lbs. @ 1.570 inch. |
| — Valve Open | 136–145 lbs. @ 1.14 inch. |
| Valve Spring Installed Height (Spring Seat to Retainer) | 39.1–40.6mm (1-17/32–1-19/32 inch.) |

ENGINE LUBRICATION

| | |
|--|--|
| Pump Type | Rotary Full Pressure |
| Capacity | 3.8 Liters (4 qts.) Without Oil Filter Change, 4.25 Liters (4.5 qts.) With Oil Filter Change. |
| Pump Drive | Crankshaft |
| Minimum Pressure, Engine Fully Warmed Up at Idle 3000 RPM | 34.47 kPa (5 psi) 205–551 kPa (30–80 psi) |
| Oil Filter Bypass Valve Setting | 62–103 kPa (9–15 psi) |
| Oil Pressure Switch Minimum Actuating Pressure | 13.79–27.58 kPa (2–4 psi) |
| Oil Filter Type | Full Flow |

OIL PUMP—INSPECTION LIMITS FOR REPLACEMENT

| | |
|--|------------------------------|
| Oil Pump Cover Out of Flat | 0.076mm (0.003 inch or more) |
| Outer Rotor Thickness | 7.63mm (0.3005 inch or less) |
| Outer Rotor Diameter | 79.78 (3.141 inch or less) |
| Inner Rotor Thickness | 7.64mm (0.301 inch or less) |
| Clearance Over Rotors— Outer | 0.10mm (0.004 inch or more) |
| — Inner | 0.10mm (0.004 inch or more) |
| Outer Rotor Clearance | 0.56mm (0.022 inch or more) |
| Tip Clearance Between Rotors | 0.20mm (0.008 inch or more) |



TORQUE

| | Thread Size | Newton Meters | Foot Pounds | Inch Pounds |
|---|-------------|---------------|-------------------------|-------------|
| A/C Compressor Bracket to Water Pump Bolt | 3/8"—16 | 41 | 30 | |
| A/C Compressor to Bracket Bolt | 7/16"—14 | 68 | 50 | |
| A/C Compressor Support Bolts | 3/8"—16 | 41 | 30 | |
| Alternator Adjusting Strap Bolt | 5/16"—18 | 23 | | 200 |
| Alternator Adjusting Strap Mounting Bolt | 3/8"—16 | 41 | 30 | |
| Alternator Bracket Bolt | 3/8"—16 | 41 | 30 | |
| Alternator Mounting Pivot Nut | 3/8"—16 | 41 | 30 | |
| Camshaft Sprocket Lockbolt | M10x1.5 | 54 | 40 | |
| Camshaft Thrust Plate | M6x1 | 12 | | 105 |
| Chain Case Cover Bolt | M8x1.25 | 47 | 20 | |
| | M10x1.5 | 54 | 40 | |
| Connecting Rod Nut | 3/8"—24 | 54 + 1/4 turn | 40 + 1/4 turn | |
| Crankshaft Pulley Screw to Crankshaft | M10x1.5 | 54 | 40 | |
| Cylinder Head Bolt | M8x1.25 | 33 | 25 | |
| Cylinder Head Bolt | M11x1.5 | | 45,65, 65 + 1/4 turn | |
| Cylinder Head Covers—Bolt | M6x1.0 | 12 | | 105 |
| Exhaust Manifold Screw | M8x1.25 | 23 | | 200 |
| Exhaust Crossover Pipe Flange Nut/Bolt | M10x1.5 | 33 | 25 | |
| Intake Manifold Bolt | M8x1.25 | 23 | | 200 |
| Intake Manifold Gasket Retaining Screws | M6x1 | 12 | | 105 |
| Intake Manifold Plenum Bolt | M8x1.75 | 28 | | 250 |
| Main Bearing Cap Bolt | M11x1.5 | 41 + 1/4 turn | 30 + 1/4 turn | |
| Oil Filter Attaching Nipple | 3/4"—16 | 41 | 30 | |
| Oil Level Sensor Plug | 3/4x16 | 27 | 20 | |
| Oil Pan Drain Plug | 1/2"—20 | 27 | 20 | |
| Oil Pan Screw | M6x1.0 | 12 | | 105 |
| Oil Pressure Gauge Sending Unit | 1/8"NPTF | 7 | | 60 |
| Oil Pump Cover Bolt T-30 | M6x1.00x18 | 12 | | 105 |
| Oil Pump Pick-up Tube Screw | M8x1.75 | 28 | | 250 |
| Rocker Shaft Bracket Bolt | 5/16"—18 | 28 | | 250 |
| Spark Plug | 14 mm | 27 | 20 | |
| Starter Mounting Bolt | 7/16"—14 | 68 | 50 | |
| Strut Intake Manifold to Cylinder Head Bolt | M10x1.5 | 54 | 40 | |
| Tappet Retainer Yoke Screw | M6x1 | 12 | | 105 |
| Temperature Gauge Sending Unit | 1/8"—NPTF | 7 | | 60 |
| Timing Chain Snubber Screw | M6x1 | 12 | | 105 |
| Water Pump to (Chain Case Cover) Bolt | M6x1.0 | 12 | | 105 |

All Fasteners Should Be Clean and Lightly Oiled.

