

WHEELS TIRES

CONTENTS

	page		page
SPECIFICATIONS	8	WHEEL SERVICE PROCEDURES	6
TIRE SERVICE PROCEDURES	1		

TIRE SERVICE PROCEDURES

INDEX

	page		page
Cleaning of Tires	2	Rotation	3
General Information	1	Tire Inflation Pressures	2
Pressure Gauges	2	Tire Noise or Vibration	3
Radial-Ply Tires	1	Tire Wear Patterns	3
Repairing Leaks	3	Tread Wear Indicators	3
Replacement Tires	3		

GENERAL INFORMATION

Throughout this group, references are made to particular vehicle by letter or number designation. A chart showing the breakdown of these designations is included in the Introduction Section.

Tires, as defined below and described in Figure 1, are designed for the vehicle. They provide the best overall performance for normal operation. The ride and handling characteristics match the vehicle's requirements. With proper care they will give excellent reliability traction, skid resistance, and tread life. These tires have a load capacity, to operate satisfactorily up to the specified Maximum Vehicle Capacity.

Driving habits have more effect on tire life than any other factor. Careful drivers will obtain, in most cases, much greater mileage than severe or careless drivers. A few of the driving habits which will shorten the life of any tire are:

- Rapid acceleration and deceleration
- Severe application of brakes
- High-speed driving
- Taking turns at excessive speeds
- Striking curbs and other obstacles

Radial ply tires are more susceptible to irregular tread wear. It is important to follow the tire rotation interval shown in the section on Tire Rotation. This will help to achieve a greater tread-life potential.

RADIAL-PLY TIRES

Radial-ply tires improve handling, tread life, ride quality and decrease rolling resistance.

Radial-ply tires must always be used in sets of four and under no circumstances should they be used on the front only. They may be mixed with temporary spare tires when necessary. Reduced speeds are recommended while temporary spare is in use.

Radial-ply tires have the same load-carrying capacity as other types of tires of the same size. They also use the same recommended inflation pressures.

Incorrect rear tire sizes may cause AWD vehicles to experience repeated failures of the Power Transfer Unit and/or Viscous Coupler.

On AWD vehicles the original equipment tires have been engineered to provide optimum performance.

Awd vehicles must have the same (all four) original equipment size tires. Unequal tire sizes must not be used.

The use of oversized tires, larger than the original equipment tires, either in the front or rear of the vehicle, can cause vehicle drive train failure. This could also cause inaccurate wheel speed signals when the vehicle is equipped with Anti-Lock Brakes.

It is recommended that tires from different manufacturers not be mixed; the tire pressure should be maintained on all four tires; and the tires should be rotated (See Owner's Manual) to keep tire wear uniform.

SPARE TIRE (COMPACT)

The compact spare tire is designed for emergency use only. The original tire should be repaired and re-

installed at the first opportunity. Refer to Owner's Manual for complete details.

TIRE CHAINS

Tire snow chains may be used on **certain** models. Refer to Owner's Manual for more information.

CLEANING OF TIRES

Remove protective coating on tires before delivery of vehicle. The coating could cause deterioration of tires.

Remove protective coating by:

- (a) Applying warm water
- (b) Letting it soak one minute
- (c) Scrubbing the coating away with a soft bristle brush.

Steam cleaning may also be used for cleaning.

DO NOT use gasoline or wire brush for cleaning.

DO NOT use mineral oil or an oil-based solvent.

PRESSURE GAUGES

A high-quality air-pressure gauge is recommended to check tire pressure. After checking with the gauge, replace valve caps and tighten finger tight.

TIRE INFLATION PRESSURES

Under inflation (Fig. 1) causes rapid shoulder wear and tire flexing and can result in tire failure.

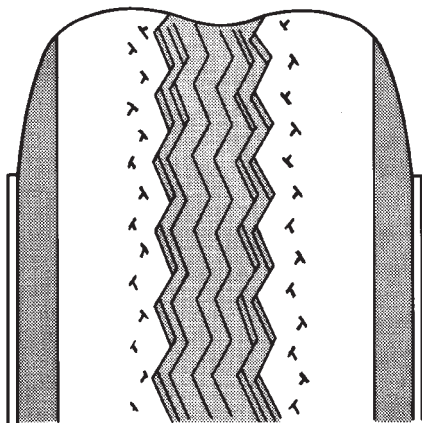

PR971B

Fig. 1 Under inflation Wear

Over inflation (Fig. 2) causes rapid center wear and loss of the tire's ability to cushion shocks.

Improper inflation can cause:

- Uneven wear patterns
- Reduced tread life
- Reduced fuel economy
- Unsatisfactory ride
- The vehicle to drift.

Proper tire pressure can be found on the Vehicle's Certification Label (See Owners Manual).

Tire pressures have been selected to provide safe vehicle operation, vehicle stability, and a comfortable ride. Tire pressure should be checked "cold" once per month. Check tire pressure more frequently when

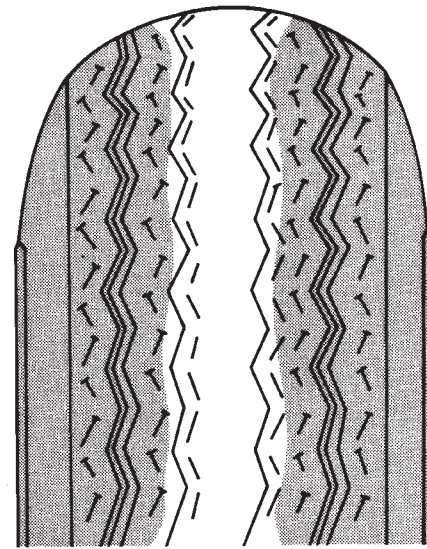

PR972A

Fig. 2 Over inflation Wear

the weather temperature varies widely. Tire pressure will decrease when the outdoor temperature drops.

Inflation pressures specified on the placards are always "cold inflation pressure". Cold inflation pressure is obtained after the vehicle has not been operated for at least 3 hours. Or the vehicle is driven less than one mile after being inoperative for 3 hours. Tire inflation pressures may increase from 2 to 6 pounds per square inch (psi) during operation. **Do not** reduce this normal pressure build-up.

Cold inflation pressures must not exceed 240 kPa (35 psi) for P-Series standard load tires.

TIRE PRESSURE FOR HIGH—SPEED OPERATION

Chrysler Corporation advocates driving at safe speeds within posted speed limits. Where speed limits allow the vehicle to be driven at high speeds, correct tire inflation pressure is very important. For speeds up to and including 75 mph (120 km/h), tires must be inflated to the pressures shown on the tire placard. For speeds in excess of 75 mph (120 km/h), tires must be inflated to the maximum pressure specified on the tire sidewall.

Vehicles loaded to the maximum capacity should not be driven at continuous speeds above 75 mph (120 km/h).

WARNING: OVER OR UNDER INFLATED TIRES CAN AFFECT VEHICLE HANDLING. THE TIRE CAN FAIL SUDDENLY, RESULTING IN LOSS OF VEHICLE CONTROL.

For police or emergency vehicles that are driven at continuous speeds over 90 mph (144 km/h), special high-speed tires must be used. Consult tire manufacturer for correct tire and inflation pressure recommendations.

REPLACEMENT TIRES

The original equipment tires provide a proper balance of many characteristics such as:

- Ride
- Noise
- Handling
- Durability
- Tread life
- Traction
- Rolling resistance
- Speed capability

It is recommend that tires equivalent to the original equipment tires be used when replacement is needed.

Failure to use equivalent replacement tires may adversely affect the safety and handling of the vehicle.

The use of oversize tires not listed in the specification charts may cause interference with vehicle components. Under extremes of suspension and steering travel interference with vehicle components may cause tire damage.

WARNING: FAILURE TO EQUIP THE VEHICLE WITH TIRES HAVING ADEQUATE SPEED CAPABILITY CAN RESULT IN SUDDEN TIRE FAILURE.

ROTATION

Tires on the front and rear axles of vehicles operate at different loads and perform different steering, driving, and braking functions. For these reasons, they wear at unequal rates, and tend to develop irregular wear patterns. These effects can be reduced by timely rotation of tires. The benefits of rotation are especially worthwhile. Rotation will increase tread life, help to maintain mud, snow, and wet traction levels, and contribute to a smooth, quiet ride.

The suggested rotation method is the "forward-cross" tire rotation method. This method takes advantage of current tire industry practice which allows rotation of radial-ply tires. Other rotation methods may be used, but may not have all the benefits of the recommended method.

For proper tire rotation, refer to the Owner's Manual.

TREAD WEAR INDICATORS

Tread wear indicators are molded into the bottom of the tread grooves. When tread is 1.6 mm (1/16 in.), the tread wear indicators will appear as a 13 mm (1/2 in.) band.

Tire replacement is necessary when indicators appear in two or more grooves or if localized balding occurs (Fig. 3).

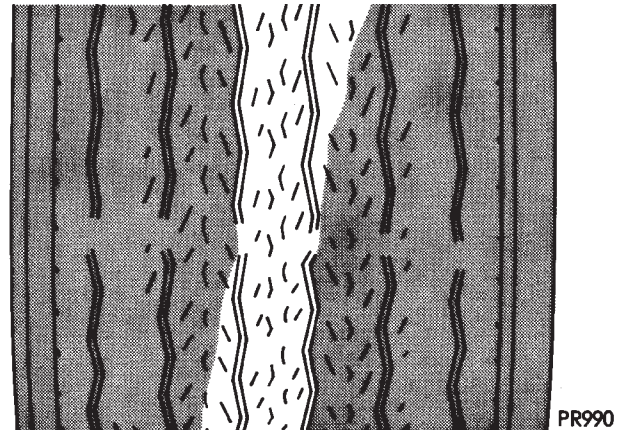

Fig. 3 Tread Wear Indicators

REPAIRING LEAKS

For proper repairing, a radial tire must be removed from the wheel. Repairs should only be made if the defect, or puncture, is in the tread area. The tire should be replaced if the puncture is located in the sidewall.

Deflate tire completely before dismounting tire from the wheel. Use lubrication such as a mild soap solution when dismounting or mounting tire. Use tools free of burrs or sharp edges which could damage the tire or wheel rim.

Before mounting tire on wheel, make sure all rust scale is removed from the rim and repaint if necessary.

Install wheels on vehicle, progressively tightening wheel nuts to 129 N•m (95 ft. lbs.) torque (See Wheels).

TIRE NOISE OR VIBRATION

Radial-ply tires are sensitive to force impulses caused by improper mounting, wheel irregularities, or imbalance.





To determine if the tires are causing the noise or vibration, drive the vehicle over a smooth road at different speeds. Note the effect of acceleration and deceleration on noise level. Differential and exhaust noises will change in intensity as speed varies, while tire noise will usually remain constant.

TIRE WEAR PATTERNS

Under inflation results in faster wear on shoulders of tire. Over inflation causes faster wear at center of tread.

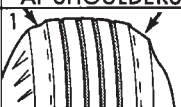
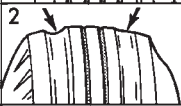
Excessive camber causes the tire to run at an angle to the road. One side of tread is worn more than the other.

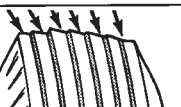
Excessive toe-in or toe-out causes wear on the tread edges of the tire, from dragging of tire. There is a feathered effect across the tread (Fig. 4).

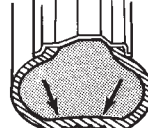
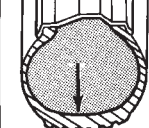
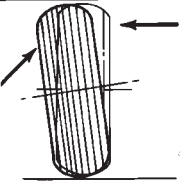
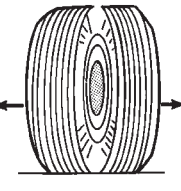
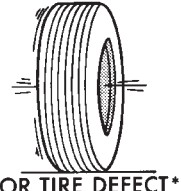
CONDITION	RAPID WEAR AT SHOULDERS	RAPID WEAR AT CENTER	WEAR ON ONE SIDE	FEATHERED EDGE	BALD SPOTS	SCALLOPED WEAR
EFFECT	 					
CAUSE	<p>UNDER-INFLATION OR LACK OF ROTATION</p> 	<p>OVER-INFLATION OR LACK OF ROTATION</p> 	<p>EXCESSIVE CAMBER</p> 	<p>INCORRECT TOE</p> 	<p>UNBALANCED WHEEL</p>  <p>OR TIRE DEFECT*</p>	<p>LACK OF ROTATION OF TIRES OR WORN OR OUT-OF-ALIGNMENT SUSPENSION</p>
CORRECTION	<p>ADJUST PRESSURE TO SPECIFICATIONS WHEN TIRES ARE COOL ROTATE TIRES</p>		<p>ADJUST CAMBER TO SPECIFICATIONS</p>	<p>ADJUST TOE-IN TO SPECIFICATIONS</p>	<p>DYNAMIC OR STATIC BALANCE WHEELS</p>	<p>ROTATE TIRES AND INSPECT SUSPENSION SEE GROUP 2</p>

9122-133

Fig. 4 Tire Wear Patterns

LEAD CORRECTION CHART

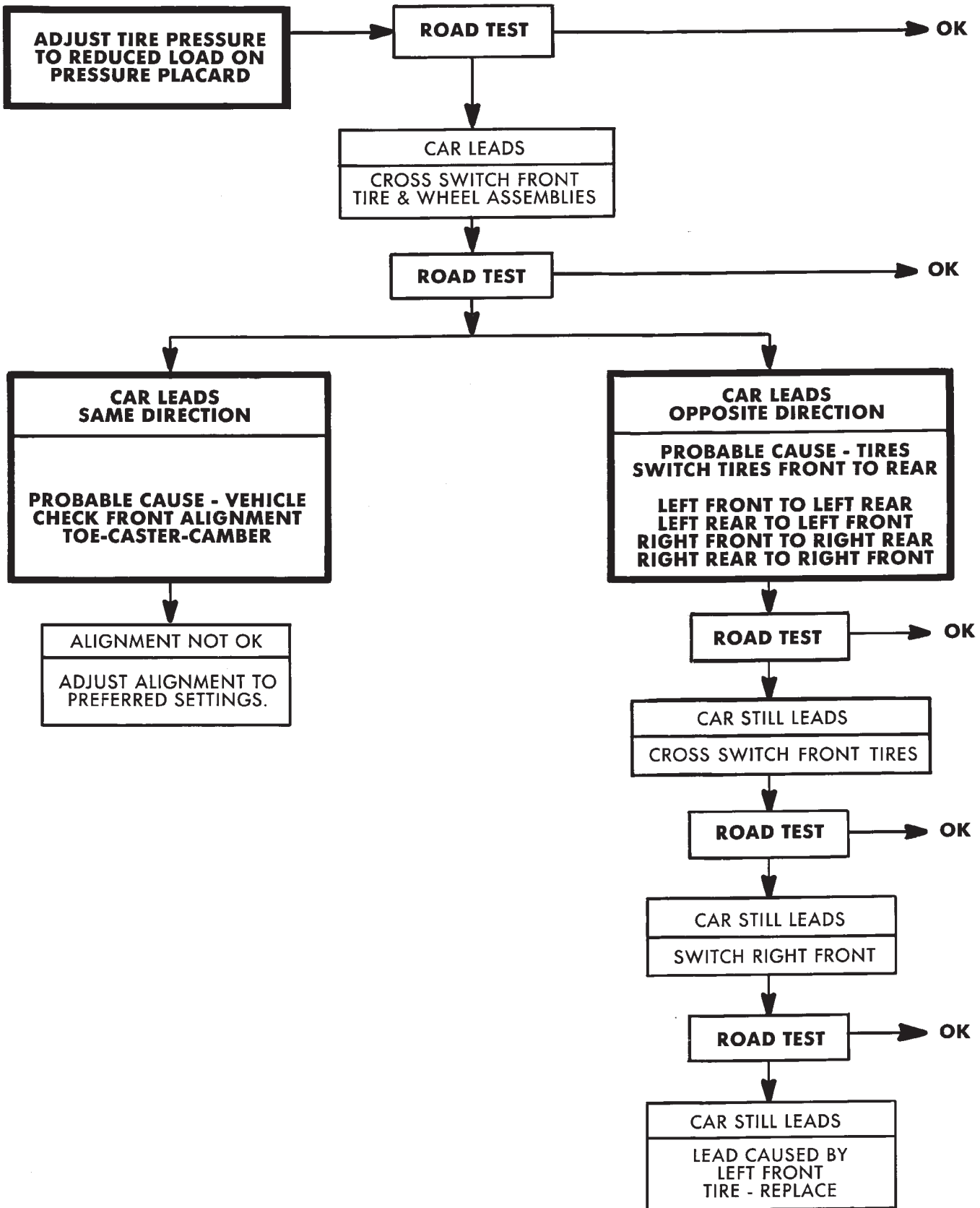

WHEEL SERVICE PROCEDURES

GENERAL INFORMATION

Original equipment wheels are designed for satisfactory operation up to the specified maximum vehicle capacity.

All models use steel or cast aluminum drop center wheels. The safety rim wheel (Fig. 1) has raised sections between the rim flanges and rim well A.

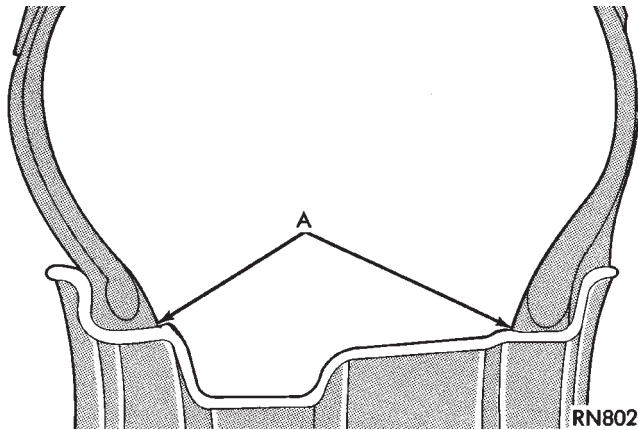

Fig. 1 Safety Rim

Initial inflation of the tires forces the bead over these raised sections. In case of tire failure, the raised sections **help** hold the tire in position on the wheel.

Cast aluminum wheels require special balance weights and alignment equipment.

WHEEL INSTALLATION

The wheel studs and nuts are designed for specific applications and must be replaced with equivalent parts. Do not use replacement parts of lesser quality or a substitute design. All aluminum and some steel wheels have wheel stud nuts with an enlarged nose. This enlarged nose is necessary to ensure proper retention of the aluminum wheels.

Before installing the wheel, remove any build up of corrosion on the wheel mounting surfaces. Installing wheels without good metal-to-metal contact could cause later loosening of wheel nuts. This could adversely affect the safety and handling of your vehicle.

To install the wheel, first position it properly on the mounting surface using the hub pilot as a guide. All wheel nuts should then be tightened just snug. Then progressively tighten them in the proper sequence (Fig. 3). Tighten wheel nuts to 129 N•m (95 ft. lbs.). **Never use oil or grease on studs or nuts.**

WHEEL REPLACEMENT

Wheels must be replaced if they:

- have excessive run out
- are bent or dented
- leak air through welds

- have damaged bolt holes

Wheel repairs employing hammering, heating, or welding are not allowed.

Original equipment replacement wheels are available through your dealer. When obtaining replacement wheels, they should be equivalent in load carrying capacity. The physical dimensions (diameter, width, offset, and mounting configuration) of the rim should be the same as the original wheel. Failure to use equivalent replacement wheels may adversely affect the safety and handling of the vehicle. **Replacement with "used" wheels is not recommended. The service history of the rim may have included severe treatment or very high mileage. The rim could fail without warning.**

TIRE AND WHEEL BALANCE

Balancing need is indicated by vibration of seats, floor pan, or steering wheel. The vibration will be noticed mostly when driving over 95 km/h (60 mph) on a smooth road.

It is recommended that a two plane dynamic tire balance machine be used. Static balancing should be used only when a two plane tire balance machine is not available.

For static imbalance, find location of heavy spot causing imbalance and counter balance wheel directly opposite the heavy spot. Determine weight required to counterbalance the area of imbalance. Place half of this weight on the **inner** rim flange. Then place the other half on the **outer** rim flange (Fig. 2).

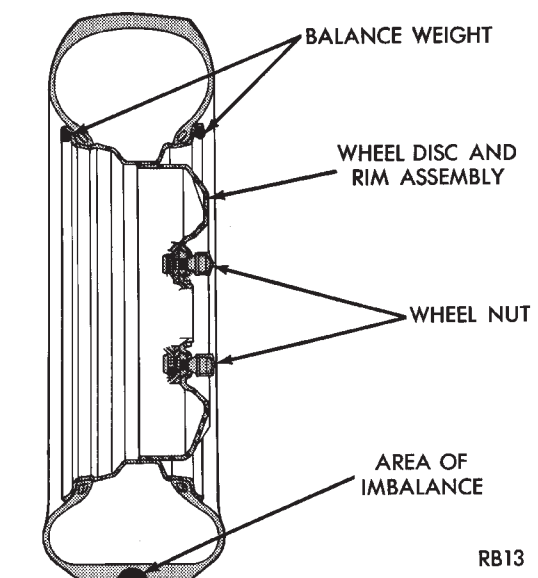

Fig. 2 Counterbalancing

Off-vehicle balancing is preferred.

TIRE AND WHEEL RUN OUT

Radial run out is the difference between the high and low points on the tire or wheel periphery.

Lateral run out is the "wobble" of the tire or wheel.

Radial run out of more than 0.7 mm (.030 inch) measured at the center line of the tread may cause the vehicle to shake.

Lateral run out of more than 0.7 mm (.030 inch) measured near the shoulder of the tire may cause the vehicle to shake.

Sometimes radial run out can be reduced by relocating the wheel and tire assembly on the mounting studs (See Method 1). If this does not reduce run out to an acceptable level, the tire can be rotated on the wheel. (See Method 2).

METHOD 1 (RELOCATE WHEEL ON HUB)

Check accuracy of the wheel mounting surface; adjust wheel bearings.

Drive vehicle a short distance to eliminate tire flat spotting from a parked position.

Make sure all wheel nuts are properly torqued (Fig. 3).

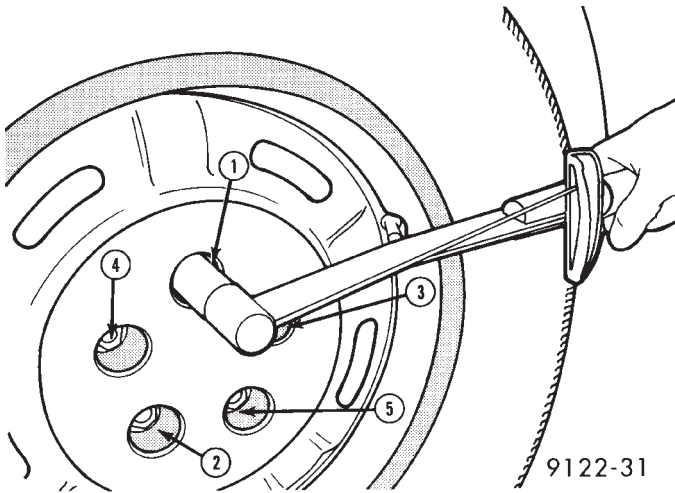

Fig. 3 Tightening Wheel Nuts

Use run out gauge D-128-TR to determine run out (Fig. 4).

Relocate wheel on the mounting, two studs over from the original position.

Retighten wheel nuts (Fig. 3) until all are properly torqued. This will prevent brake distortion.

Check radial run out. If still excessive, mark tire sidewall, wheel, and stud at point of maximum run out and proceed to Method 2.

METHOD 2 (RELOCATE TIRE ON WHEEL)

Rotating tire on wheel is particularly effective when there is run out in both tire and wheel.

Remove tire from wheel and mount wheel on dynamic wheel balancer.

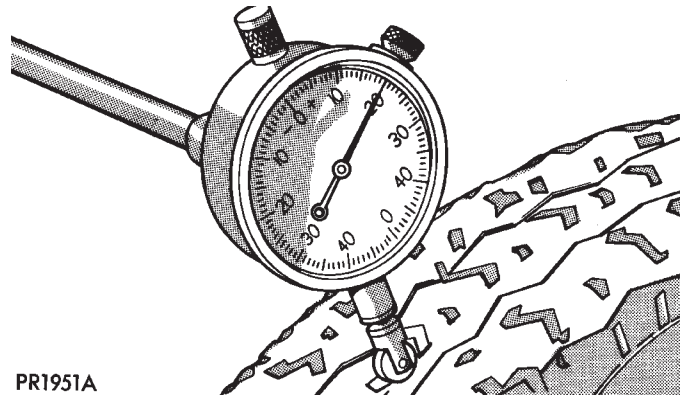

Fig. 4 Run out Gauge

Check wheel radial run out at each bead seat (Fig. 5). It should be no more than 0.7 mm (0.30 inch).

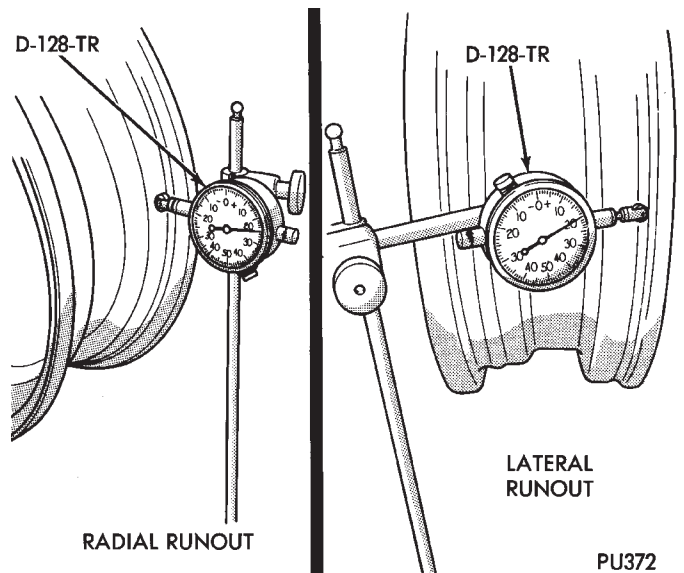

Fig. 5 Checking Wheel Run out

Lateral run out on each rim should be no more than 0.7 mm (0.30 inch) (Fig. 5).

If point of greatest wheel radial run out is near original chalk mark, remount tire 45 degrees from its original position. Recheck run out.



SPECIFICATIONS

SPECIFICATIONS

The following guide should help you understand the tire designations:

P	Passenger car tire (or "T" for temporary-use tire).
185	Nominal width of tire in millimeters.
70	Tire height-to-width ratio.
R	Radial-ply tire (or "D" for bias-ply tire).
14	Nominal rim diameter in inches.

Do not install smaller than minimum size tires shown on the tire inflation placard on the vehicle.

9122-75

TIGHTENING REFERENCE

Stud Size	M12 × 1.5mm
Nut Size	19mm
Torque Wheel Nuts (4 or 5 Stud)	129 N·m (95 ft. lbs)

9122-76