

HEATING AND AIR CONDITIONING

CONTENTS

	page		page
AUXILIARY REAR HEATING OR HEATING-AIR/CONDITIONING	27	HEATER AND A/C PERFORMANCE TESTS	5
COMPONENT SERVICE PROCEDURES	11	REFRIGERANT SERVICE PROCEDURES	7
GENERAL INFORMATION	1	VACUUM CONTROL SYSTEM DIAGNOSIS	3

GENERAL INFORMATION

INDEX

	page		page
Cooling System Precautions	2	Safety Precautions and Warnings	2
Description and Operation	1	Side Window Demisters	2
Engine Cooling System Requirements	2	System Airflow	1
Handling Tubing and Fittings	2		

DESCRIPTION AND OPERATION

Both the heater and the heater/air conditioning systems share many of the same components. This Group will deal with both systems together when component function is common, and separately when they are not.

For proper operation of the instrument panel controls, refer to the Owner's Manual provided with the vehicle.

All vehicles are equipped with a common A/C-heater unit housing assembly. When the vehicle has only a heater system, the evaporator and recirculating air door are omitted (Fig. 1).

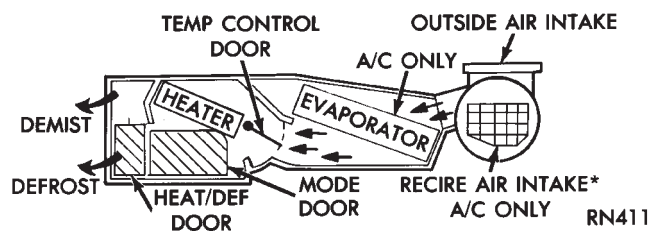
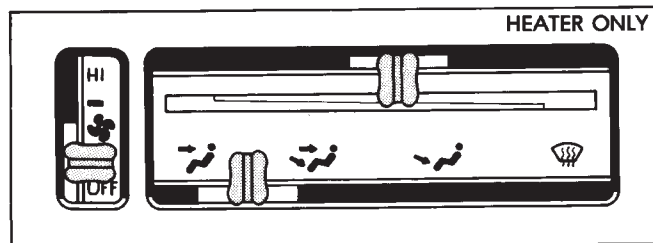
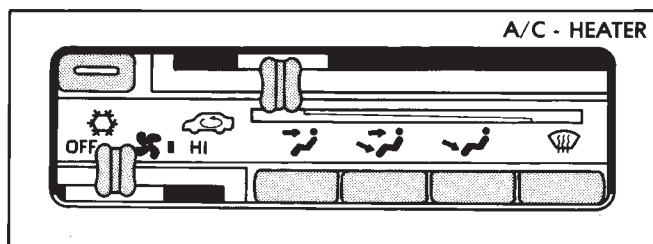

Fig. 1 Common Blend-Air Heater A/C System

SYSTEM AIRFLOW

The system pulls outside (ambient) air through the cowl opening at the base of the windshield. Then it goes into the plenum chamber above the A/C-heater unit housing. On air-conditioned vehicles, the air passes through the evaporator. At this point the air flow can be directed either through or around the heater core. This is done by adjusting the blend-air door with the TEMP control on the instrument panel. The air flow can then be directed from the PANEL, BI-LEVEL (panel and floor), and FLOOR-DEFROST outlets. Air flow velocity can be adjusted with the blower speed selector switch on the instrument panel (Fig. 2).



9124-1

Fig. 2 Heater only or Heater-A/C Controls

On air-conditioned vehicles, ambient air intake can be shut off by closing the recirculating air door. This will recirculate the air that is already inside the vehicle. This is done by moving the TEMP control into the RECIRC position. Depressing the DEFROST or A/C button will engage the compressor. This will send refrigerant through the evaporator, and will remove heat and humidity from the air before it is directed through or around the heater core.

SIDE WINDOW DEMISTERS

The side window demisters direct air from the heater assembly. The outlets are located on the top outboard corners of the instrument panel. The Demisters operate when the A/C control mode selector is on FLOOR or DEFROST setting.

ENGINE COOLING SYSTEM REQUIREMENTS

To maintain adequate temperature levels from the heating/air-conditioning system, the engine cooling system must be in proper working order. Refer to Group 0, Lubrication and Maintenance, or Group 7, Cooling System of this manual.

The use of a bug screen is not recommended. Any obstructions forward of the condenser can reduce the effectiveness of the air-conditioning system.

SAFETY PRECAUTIONS AND WARNINGS

WARNING: WEAR EYE PROTECTION WHEN SERVICING THE AIR-CONDITIONING REFRIGERANT SYSTEM. SERIOUS EYE INJURY CAN RESULT FROM EYE CONTACT WITH REFRIGERANT. IF EYE CONTACT IS MADE, SEEK MEDICAL ATTENTION IMMEDIATELY.

DO NOT EXPOSE REFRIGERANT TO OPEN FLAME. POISONOUS GAS IS CREATED WHEN REFRIGERANT IS BURNED. AN ELECTRONIC TYPE LEAK DETECTOR IS RECOMMENDED.

LARGE AMOUNTS OF REFRIGERANT RELEASED IN A CLOSED WORK AREA WILL DISPLACE THE OXYGEN AND CAUSE SUFFOCATION.

THE EVAPORATION RATE OF REFRIGERANT AT AVERAGE TEMPERATURE AND ALTITUDE IS EXTREMELY HIGH. AS A RESULT, ANYTHING THAT COMES IN CONTACT WITH THE REFRIGERANT WILL FREEZE. ALWAYS PROTECT SKIN OR DELICATE OBJECTS FROM DIRECT CONTACT WITH REFRIGERANT.

R-134A SERVICE EQUIPMENT OR VEHICLE A/C SYSTEM SHOULD NOT BE PRESSURE TESTED OR LEAK TESTED WITH COMPRESSED AIR. SOME MIXTURES OF AIR/R-134A HAVE BEEN SHOWN TO BE COMBUSTIBLE AT ELEVATED PRESSURES. THESE MIXTURES ARE POTENTIALLY DANGEROUS AND MAY RESULT IN FIRE OR EXPLOSION CAUSING INJURY OR PROPERTY DAMAGE.

COOLING SYSTEM PRECAUTIONS

WARNING: ANTIFREEZE IS AN ETHYLENE GLYCOL BASE COOLANT AND IS HARMFUL IF SWALLOWED OR INHALED. SEEK MEDICAL ATTENTION IMMEDIATELY IF SWALLOWED OR INHALED.

DO NOT STORE IN OPEN OR UNMARKED CONTAINERS.

WASH SKIN AND CLOTHING THOROUGHLY AFTER COMING IN CONTACT WITH ETHYLENE GLYCOL.

KEEP OUT OF REACH OF CHILDREN AND PETS.

DO NOT OPEN A COOLING SYSTEM WHEN THE ENGINE IS AT RUNNING TEMPERATURE. PERSONAL INJURY CAN RESULT.

The engine cooling system is designed to develop internal pressure of 97 to 123 kPa (14 to 18 psi). Allow the vehicle approximately 15 minutes (or until a safe temperature and pressure are attained) before opening the cooling system. Refer to Group 7, Cooling System.

HANDLING TUBING AND FITTINGS

Kinks in the refrigerant tubing or sharp bends in the refrigerant hose lines will greatly reduce the capacity of the entire system. High pressures are produced in the system when it is operating. Extreme care must be exercised to make sure that all connections are pressure tight. Dirt and moisture can enter the system when it is opened for repair or replacement of lines or components. The refrigerant oil will absorb moisture readily out of the air. This moisture will convert into acids within a closed system.

The following precautions must be observed:

The system must be completely empty before opening any fitting or connection in the refrigeration system. Open fittings with caution even after the system has been emptied. If any pressure is noticed as a fitting is loosened, allow trapped pressure to bleed off very slowly.

A good rule for the flexible hose lines is to keep the radius of all bends at least 10 times the diameter of the hose. Sharper bends will reduce the flow of refrigerant. The flexible hose lines should be routed so they are at least 3 inches (80 mm) from the exhaust manifold. Inspect all flexible hose lines to make sure they are in good condition and properly routed.

Unified plumbing connections with aluminum gaskets cannot be serviced with O-rings. These gaskets are not reusable and do not require lubrication before installing.

The use of correct wrenches when making connections is very important. Improper wrenches or improper use of wrenches can damage the fittings.

The internal parts of the A/C system will remain chemical stable as long as pure-moisture-free refrigerant and refrigerant oil is used. Abnormal amounts of dirt, moisture or air can upset the chemical stability. This may cause operational troubles or even serious damage if present in more than very small quantities.

When opening a refrigeration system, have everything you will need to repair the system ready. This will minimize the amount of time the system must be opened. Cap or plug all lines and fittings as soon as they are opened. This will help prevent the entrance or dirt and moisture. All new lines and components should be capped or sealed until they are ready to be used.

All tools, including the refrigerant dispensing manifold, the manifold gauge set, and test hoses should be kept clean and dry.

VACUUM CONTROL SYSTEM DIAGNOSIS

GENERAL INFORMATION

Use an adjustable Vacuum Test Gauge (C-3707) and a suitable vacuum pump to test heater A/C control vacuum. With a finger placed over the end of test hose (Fig. 1), calibrate vacuum control valve on the test gauge to obtain -27 kPa (8 in. Hg.). Release and block the end of the test hose several times to verify vacuum setting.

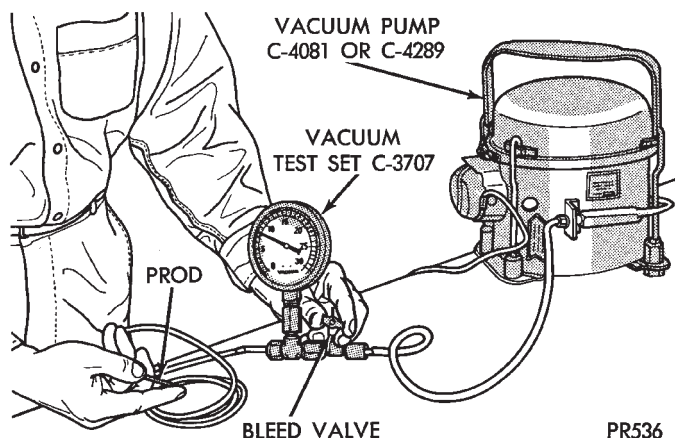

Fig. 1 Adjust Vacuum Test Bleed Valve

VACUUM TESTING THE ONE-WAY CHECK VALVE

(1) In the engine compartment, disconnect the Heater-A/C vacuum supply (black) hose. This hose passes through an opening in the dash panel used for the air conditioning expansion valve.

(2) Remove the vacuum check valve. This valve is located on the (black) vacuum supply hose at the brake power booster.

(3) Connect test vacuum supply hose to the HEATER side of the valve. In this direction the gauge should return to calibrated setting. If valve leaks vacuum in this direction, valve replacement is necessary.

(4) Connect test vacuum supply hose to the ENGINE VACUUM side of the valve. Vacuum should flow through valve.

VACUUM TESTING THE HEATER-A/C CONTROLS

(1) Connect the test vacuum prod to the vehicles (black) vacuum supply hose. Position vacuum test gauge so it can be viewed from the passenger compartment.

(2) Position the heater A/C control mode selector to DEFROST, FLOOR, BI-LEVEL, PANEL, and RE-CIRC (with A/C). Pause after each selection. The test

gauge should return to the calibrated setting of -27 kPa (8 in. Hg.) after each selection is made. If the gauge cannot achieve the calibrated setting, a vacuum circuit or component has a leak.

LOCATING VACUUM LEAKS

To locate a vacuum leak, disconnect 7-way vacuum connector behind the instrument panel at the heater A/C control. For removal and installation of heater A/C control panel, refer to the Switch and Panel Component Service section of Group 8E, Instrument Panel. Connect the calibrated vacuum hose prod (Fig. 4) to each port in the vacuum harness connector (Fig. 2). The brown, bi-level, vacuum circuit has a metal fiber restrictive device located in the line. More reaction time is required for the test gauge to return to calibrated setting. After each connection is made, the test gauge should return to calibrated setting. If all circuits function properly, replace control mode vacuum switch. If not, determine the color of the vacuum circuit that is leaking. To determine vacuum line colors, refer to the Vacuum Circuits-Heater or Heater A/C Control chart in this section. Disconnect the vacuum actuator at the other end of the circuit. (Instrument panel removal may be necessary to gain access to some components). Block the end of the disconnected vacuum line. The test gauge should return to calibrated setting. If not, that circuit has a leak and must be repaired or replaced. If test gauge returns to calibrated setting, the vacuum actuator must be replaced.

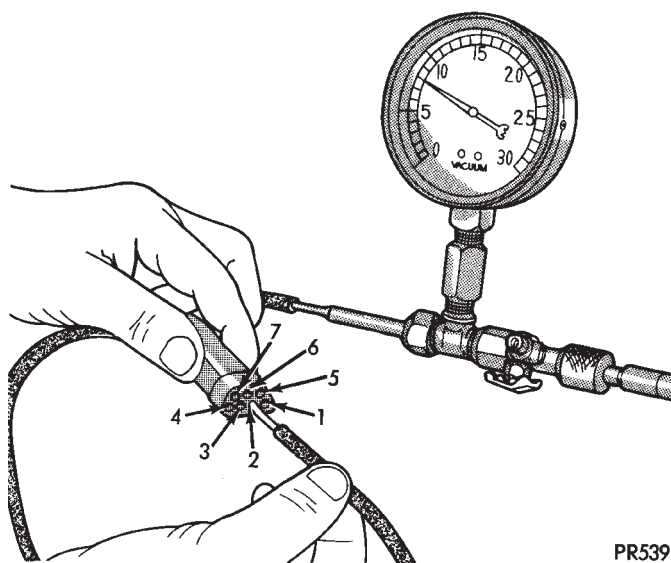
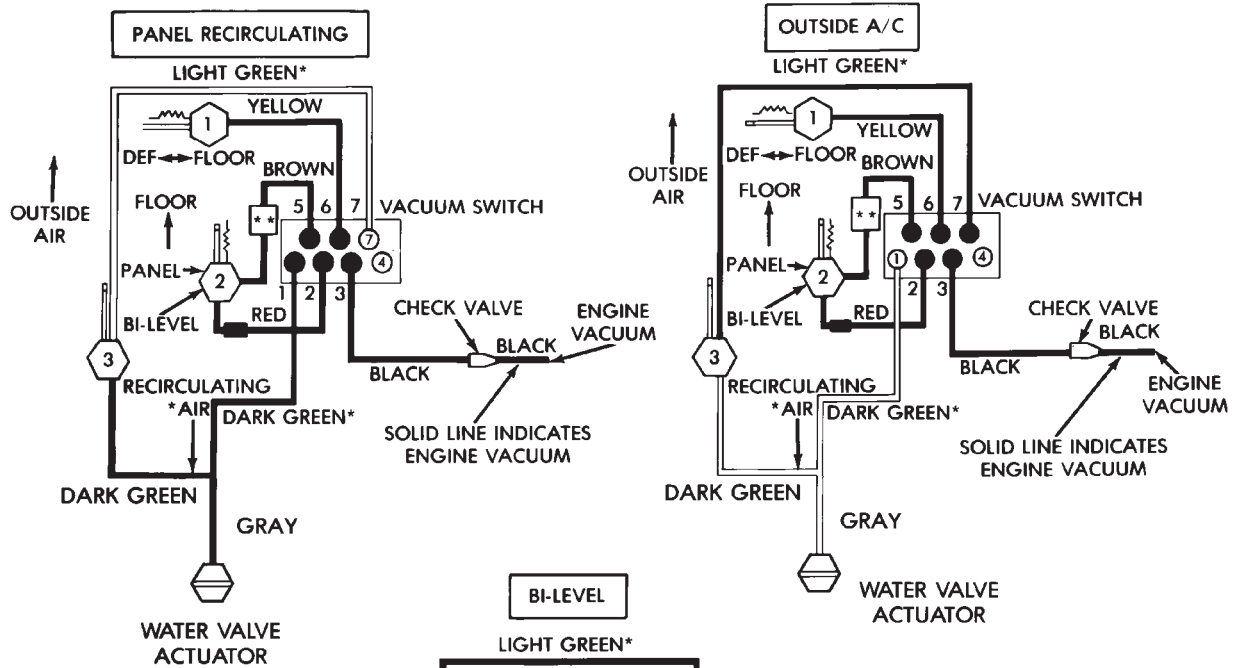

Fig. 2 Vacuum Circuit Test



VACUUM CIRCUITS—HEATER OR HEATER A/C CONTROL



VACUUM ACTUATORS

- ① FLOOR-DEFROST
- ② PANEL-FLOOR-BI-LEVEL
- ③ RECIRCULATING AIR*

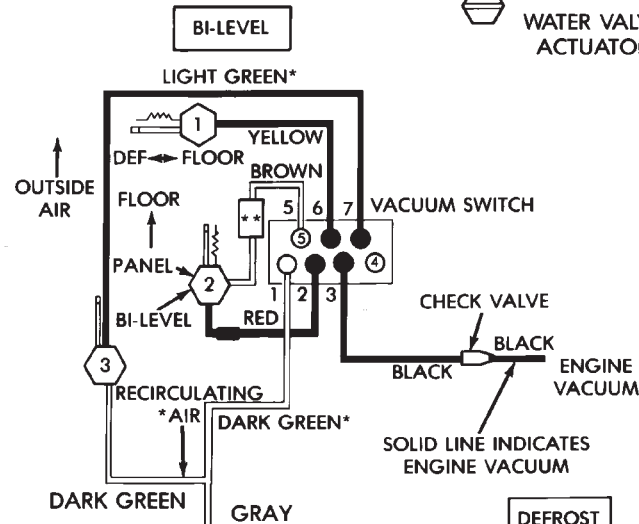

*A/C ONLY
**RESTRICTOR IS PART OF VACUUM LINE AND IS NOT VISIBLE

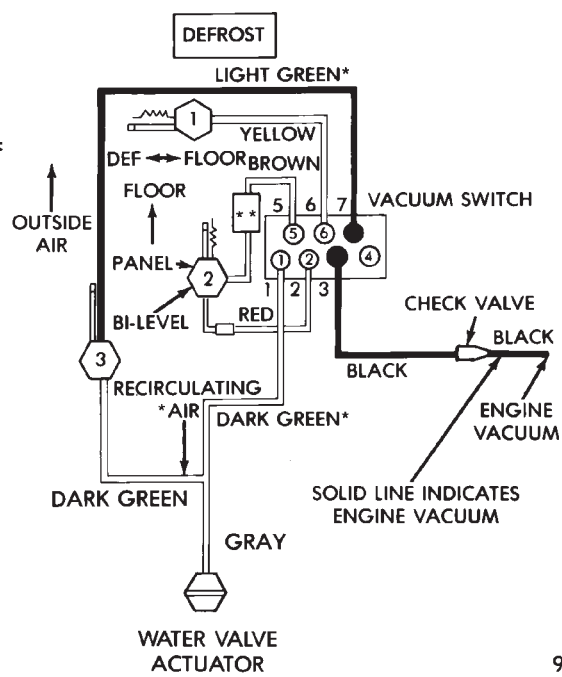
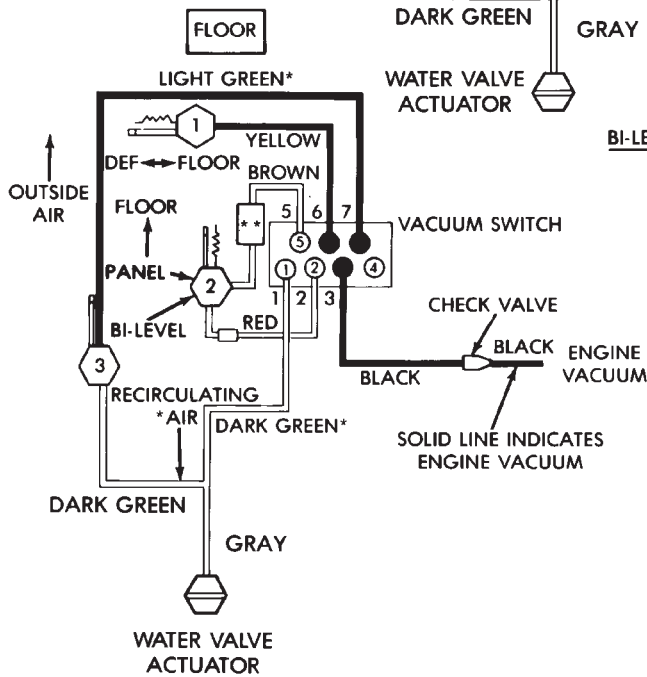

HEATER AND A/C PERFORMANCE TESTS

HEATER OUTPUT TEST

PRE-DIAGNOSTIC PREPARATIONS

Review Safety Precautions and Warnings in the General Information section of this Group before performing the following procedures.

Check the coolant level, drive belt tension, vacuum line connections, radiator air flow and fan operation. Start engine and allow to warm up to normal running temperature.

WARNING: DO NOT REMOVE RADIATOR CAP WHEN ENGINE IS HOT, PERSONAL INJURY CAN RESULT.

If vehicle has been run recently, wait 15 minutes before removing cap. Place a rag over the cap and turn it to the first safety stop. Allow pressure to escape through the overflow tube. When the system stabilizes, remove the cap completely.

MAXIMUM HEATER OUTPUT: TEST AND ACTION

Engine coolant is provided to the heater system by two 16 mm (5/8 inch inside diameter) heater hoses. With engine idling at normal running temperature, set the control to maximum heat, floor, and high blower setting. Using a test thermometer, check the air temperature coming from the floor outlets, refer to Temperature Reference chart.

TEMPERATURE REFERENCE CHART

Ambient Temperature		Minimum Heater System Floor Outlet Temperature	
Celsius	Fahrenheit	Celsius	Fahrenheit
15.5°	60°	62.2°	144°
21.1°	70°	63.8°	147°
26.6°	80°	65.5°	150°
32.2°	90°	67.2°	153°

9124-4

If the floor outlet air temperature is insufficient, refer to Group 7, Cooling Systems for specifications. Both heater hoses should be HOT to the touch (coolant return hose should be slightly cooler than the supply hose). If coolant return hose is much cooler than the supply hose, locate and repair engine coolant flow obstruction in heater system.

POSSIBLE LOCATIONS OR CAUSE OF OBSTRUCTED COOLANT FLOW

- (a) Pinched or kinked heater hoses.
- (b) Improper heater hose routing.
- (c) Plugged heater hoses or supply and return

ports at cooling system connections, refer to Group 7, Cooling System.

- (d) Plugged heater core.
- (e) Water valve sticking or inoperative.

If coolant flow through heater system is verified and outlet air temperature is insufficient, a mechanical problem may exist.

POSSIBLE LOCATION OR CAUSE OF INSUFFICIENT HEAT

- (a) Obstructed cowl air intake.
- (b) Obstructed heater system outlets.
- (c) Blend-air door not functioning properly.

TEMPERATURE CONTROL

If temperature cannot be adjusted with the TEMP lever on the control panel, or TEMP lever is difficult to move, the following could require service:

- (a) Blend-air door binding.
- (b) Control cables miss-routed, pinched, kinked, or disconnected.
- (c) Improper engine coolant temperature.

A/C PERFORMANCE TEST

The air-conditioning system is designed to remove heat and humidity from the air entering the passenger compartment. The evaporator, located in the heater A/C unit behind the instrument panel, is cooled to temperatures near the freezing point. As warm damp air passes over the fins in the evaporator, moisture in the air condenses to water, dehumidifying the air. Condensation on the evaporator fins reduces the evaporators ability to absorb heat. During periods of high heat and humidity, an air-conditioning system will be less effective than during periods of high heat and low humidity. With the instrument control set to RECIRC, only air from the passenger compartment passes through the evaporator. As the passenger compartment air dehumidifies, A/C performance levels rise.

PERFORMANCE TEST PROCEDURE

Review Safety Precautions and Warnings in the General Information section of this Group before proceeding with this procedure. Air temperature in test room and on vehicle must be 70°F (21°C) minimum for this test.

- (1) Connect a tachometer and manifold gauge set.
- (2) Set control to A/C, RECIRC, PANEL, or MAX A/C, temperature lever on full cool and blower on high.
- (3) Start engine and hold at 1000 rpm with A/C clutch engaged.
- (4) Engine should be warmed up with doors and windows closed.

(5) Insert a thermometer in the left center A/C outlet and operate the engine for five minutes. The A/C clutch may cycle depending on ambient conditions.

(6) With the A/C clutch engaged, compare the discharge air temperature to the A/C Performance Temperatures chart.

(7) If the discharge air temperature fails to meet the specifications in the performance temperature chart. Refer to the Diagnostic Analysis charts in this Group for further test information.

A/C PERFORMANCE TEMPERATURES

Ambient Temperature	21°C (70°F)	26.5°C (80°F)	32°C (90°F)	37.5°C (100°F)	43°C (110°F)
Air Temperature at Center Panel Outlet	2-8°C (35-46°F)	4-10°C (39-50°F)	7-13°C (44-55°F)	10-17°C (50-62°F)	13-21°C (56-70°F)
Compressor Discharge Pressure	965- 1448 kPa (140-210 PSI)	1240- 1620 kPa (180-235 PSI)	1448- 1860 kPa (210-270 PSI)	1655- 2137 kPa (240-310 PSI)	1930- 2413 kPa (280-350 PSI)
Evaporator Suction Pressure	69- 241 kPa (10-35 PSI)	110- 262 kPa (16-38 PSI)	138- 290 kPa (20-42 PSI)	172- 331 kPa (25-48 PSI)	207- 379 kPa (30-55 PSI)

REFRIGERANT SERVICE PROCEDURES

INDEX

	page		page
Adding Partial Refrigerant Charge	9	R-134a Refrigerant	7
Charging Refrigerant System—Empty System	9	Sight Glass Refrigerant Level Inspection	8
Evacuating Refrigerant System	9	System Leak Checking	8

R-134a REFRIGERANT

This vehicle uses a new type of refrigerant called R-134a. It is a non-toxic, non-flammable, clear colorless liquified gas.

R-134a refrigerant is not compatible with R-12 refrigerant in an air conditioning system. Even a small amount of R-12 in a R-134a system will cause compressor failure, refrigerant oil sludging or poor air conditioning system performance. **Never add R-12 to a system designed to use R-134a. System failure will occur.**

Both of the service ports to charge the air conditioning system are located on the hose. New design of service ports have been used to ensure that the system is not accidentally filled with the wrong refrigerant (R-12).

When servicing a system, it is required that a air-conditioning charging recovery/recycling machine be used (Fig. 1). Contact an automotive service equipment supplier for refrigerant recycling/recovering equipment. Refer to the operating instructions provided with the equipment for proper operation.

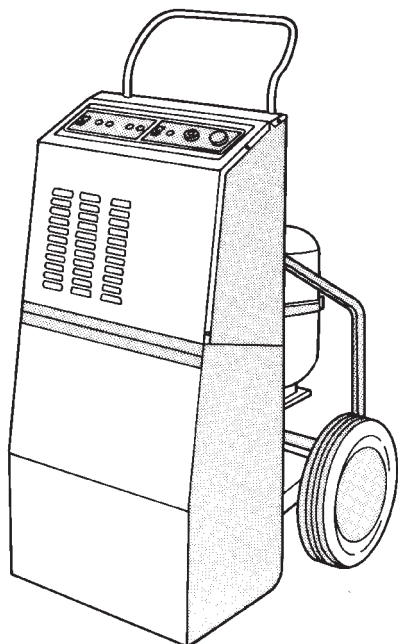

9124-3

Fig. 1 Refrigerant Recovery/Recycling Station—Typical

A manifold gauge set (Fig. 2) must also be used in conjunction with the charging and/or recovery/recycling device. The service hoses on the gauge set should have manual (turn wheel) or automatic back flow valves at the service port connector ends. This will prevent refrigerant R-134a from being release into the atmosphere.

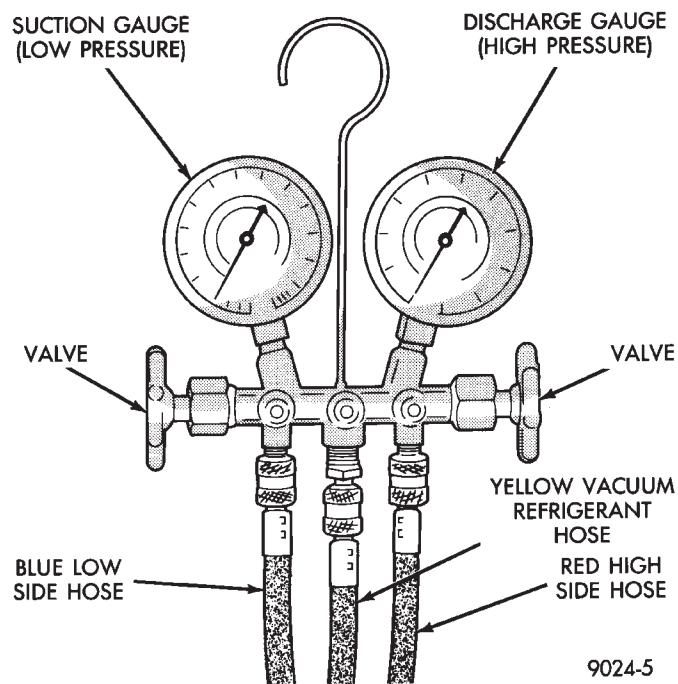

Fig. 2 Manifold Gauge Set—Typical

R-134a refrigerant requires a special type of compressor oil. When adding oil, make sure that it is designed to be used in a R-134a system.

Due to the different characteristics of R-134a it requires all new service procedures.

WARNING: AVOID BREATHING A/C REFRIGERANT AND LUBRICANT VAPOR OR MIST. EXPOSURE MAY IRRITATE EYES, NOSE AND THROAT. USE ONLY APPROVED SERVICE EQUIPMENT MEETING SAE REQUIREMENTS TO RECLAIM R-134A SYSTEMS. IF ACCIDENTAL SYSTEM DISCHARGE OCCURS, VENTILATE WORK AREA BEFORE RESUMING SERVICE.

WARNING: R-134A SERVICE EQUIPMENT OR VEHICLE A/C SYSTEM SHOULD NOT BE PRESSURE TESTED OR LEAK TESTED WITH COMPRESSED AIR. SOME MIXTURES OF AIR/R-134A HAVE BEEN SHOWN TO BE COMBUSTIBLE AT ELEVATED PRESSURES. THESE MIXTURES ARE POTENTIALLY DANGEROUS AND MAY RESULT IN FIRE OR EXPLOSION CAUSING INJURY OR PROPERTY DAMAGE.

The use of R-134a will have a positive environmental impact due to its zero ozone depletion and low global warming impact.

SIGHT GLASS REFRIGERANT LEVEL INSPECTION

The filter-drier is equipped with a sight glass (Fig. 3) that is used as a refrigerant level indicator only. **This sight glass is not to be used for A/C performance testing.** To check the refrigerant level, remove the vehicle jack and clean the sight glass. Then start and warm up engine, and hold idle at 1100 rpm. Place the air-conditioning control on A/C, RE-CIRC and high blower. The work area temperature should be at least 21°C (70°F). If the compressor does not engage, the refrigerant level is probably too low for the Low Pressure Cut-Off switch to detect. If compressor clutch does not engage, refer to Testing Refrigerant System for Leaks in this Group. If compressor clutch engages, allow approximately one minute for refrigerant to stabilize. View refrigerant through sight glass. The suction line should be cold to the touch and the sight glass should be clear.

CAUTION: The filter/drier used in a 134a refrigerant system will not interchange with a filter/drier from a R-12 refrigerant system.

If foam or bubbles are visible in sight glass, the refrigerant level is probably low. Occasional foam or bubbles are normal when the work area temperature is above 43°C (110°F) or below 21°C (70°F). If suction line is cold and occasional bubbles are visible in the sight glass, block the condenser air flow. This will increase the compressor discharge pressure (Do not allow engine to over heat). Bubbles should dissipate. If not, the refrigerant level is low.

SYSTEM LEAK CHECKING

If the A/C system is not cooling properly, determine if the refrigerant system is fully charged with R-134a. If the refrigerant system is empty or low in refrigerant charge, a leak at any line fitting or component seal is likely. To detect a leak in the refrigerant system, perform one of the following procedures as indicated by the symptoms.

WARNING: AVOID BREATHING A/C REFRIGERANT AND LUBRICANT VAPOR OR MIST. EXPOSURE

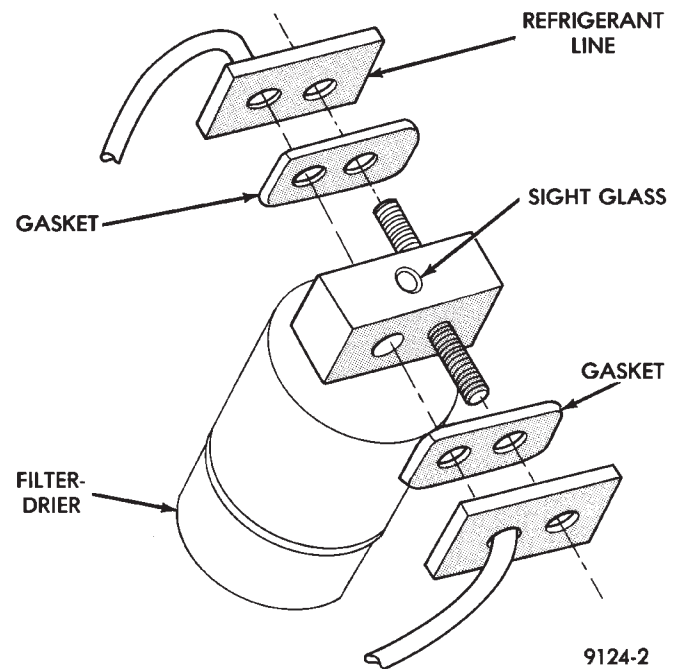

Fig. 3 Filter Drier and Sight Glass

MAY IRRITATE EYES, NOSE AND THROAT. USE ONLY APPROVED SERVICE EQUIPMENT MEETING SAE REQUIREMENTS TO RECLAIM R-134A SYSTEM. IF ACCIDENTAL SYSTEM DISCHARGE OCCURS, VENTILATE WORK AREA BEFORE RESUMING SERVICE.

WARNING: R-134A SERVICE EQUIPMENT OR VEHICLE A/C SYSTEM SHOULD NOT BE PRESSURE TESTED OR LEAK TESTED WITH COMPRESSED AIR. SOME MIXTURES OF AIR/R-134A HAVE BEEN SHOWN TO BE COMBUSTIBLE AT ELEVATED PRESSURES. THESE MIXTURES ARE POTENTIALLY DANGEROUS AND MAY RESULT IN FIRE OR EXPLOSION CAUSING INJURY OR PROPERTY DAMAGE.

EMPTY REFRIGERANT SYSTEM LEAK TEST

- (1) Evacuate the refrigerant system to the lowest degree of vacuum possible.
- (2) Prepare a 10 oz. refrigerant charge to be injected into the system.
- (3) Connect and dispense 10 ozs. of refrigerant into the evacuated refrigerant system.
- (4) Proceed to step two of Low Refrigerant Level Leak Test.

LOW REFRIGERANT LEVEL LEAK TEST

- (1) Determine if there is any (R-134a) refrigerant in the system.
- (2) Position the vehicle in a wind free work area. This will aid in detecting small leaks.

(3) Bring the refrigerant system up to operating temperature and pressure. This is done by allowing the engine to run for five minutes.

CAUTION: A leak detector designed for R-12 refrigerant will not detect leaks in a R-134a refrigerant system.

(4) With the engine not running, use an Electronic Leak Detector that is designed to detect R-134a type refrigerant and search for leaks. Fittings, lines, or components that appear to be oily usually will indicate a refrigerant leak. To inspect the evaporator core for leaks, it is possible to insert the leak detector probe into the recirculating air door opening.

ADDING PARTIAL REFRIGERANT CHARGE

If it was not necessary to completely empty the refrigerant system, a partial refrigerant charge can be added to the system.

CAUTION: Review all Safety Precautions and Warnings in the General Information Section before adding refrigerant to the system. Do not add refrigerant to a system that is known to have a leak.

- (1) Attach manifold gauge set.
- (2) Open the windows of the passenger compartment and set the air-conditioning controls to A/C, RECIRC, and Low blower speed.
- (3) Start the engine and allow it to warm up to normal running temperature.
- (4) If the air-conditioning compressor does not engage, disconnect the low pressure cut-off switch. Place a jumper wire across the terminals in the connector boot. If the compressor still does not engage, a problem exists in the compressor clutch feed circuit.
- (5) Hold the engine speed at 1400 rpm.
- (6) While following the instructions provided with the charging equipment being used, charge through the suction side of the system. Add enough refrigerant to clear the sight glass in the filter drier.
- (7) At the point when the sight glass clears, note the weight of the refrigerant supply drum or the level in the charging cylinder. Add an additional 227 g (8 oz) of refrigerant to the system. Remove the jumper wire from the low pressure cut-off switch connector and connect the cut-off switch.
- (8) Test the over all performance of the air-conditioner. Close all valves on the charging equipment and disconnect the hoses from the service ports. Install the service port caps.

EVACUATING REFRIGERANT SYSTEM

Special effort must be used to keep all R-134a system components capped to prevent moisture from entering the A/C system oil. Moisture in the

oil is very difficult to remove and will cause a reliability problem with the compressor.

If a compressor designed to use R-134a refrigerant is left open to the atmosphere for an extended period of time. It is recommended that the refrigerant oil be drained and replaced with new oil or a new compressor be used. This will eliminate the possibility of contaminating the refrigerant system.

If the refrigerant system has been open to the atmosphere, it must be evacuated before the system can be filled. Moisture and air mixed with the refrigerant will raise the compressor head pressure above acceptable operating levels. This will reduce the performance of the air-conditioner and damage the compressor. Moisture will boil at near room temperature when exposed to vacuum. To evacuate the refrigerant system:

(1) Connect a suitable charging station, refrigerant recovery machine, and a manifold gauge set with vacuum pump.

(2) Open the suction and discharge valves and start the vacuum pump. The vacuum pump should run a minimum of 45 minutes prior to charge to eliminate all moisture in system. When the suction gauge reads -88 kPa (-26 in. Hg) vacuum or greater for 45 minutes, close all valves and turn off vacuum pump. If the system fails to reach specified vacuum, the refrigerant system likely has a leak that must be corrected. If the refrigerant system maintains specified vacuum for at least 30 minutes, start the vacuum pump, open the suction and discharge valves. Then allow the system to evacuate an additional 10 minutes.

(3) Close all valves. Turn off and disconnect the vacuum pump.

The refrigerant system is prepared to be charged with refrigerant.

CHARGING REFRIGERANT SYSTEM—EMPTY SYSTEM

CAUTION: Do not over charge refrigerant system, as excessive compressor head pressure can cause noise and system failure.

WARNING: REVIEW SAFETY PRECAUTIONS AND WARNINGS IN GENERAL INFORMATION SECTION OF THIS GROUP BEFORE CHARGING THE REFRIGERANT SYSTEM.

After the system has been tested for leaks and evacuated, a refrigerant (R-134a) charge can be injected into the system.

- (1) Connect manifold gauge set.



(2) Measure refrigerant (refer to capacities) and heat to 52°C (125°F) with the charging station. Refer to the instructions provided with the equipment being used.

REFRIGERANT CAPACITIES:

- Without Rear A/C = 1020 g (36 oz.)
- With Rear A/C = 1420 g (50 oz.)

(3) Open the suction and discharge valves. Open the charge valve to allow the heated refrigerant to flow into the system. When the transfer of refrigerant has stopped, close the suction and discharge valve.

(4) If all of the charge did not transfer from the dispensing device, run engine at a high idle (1400 rpm). Set the A/C control to A/C, low blower speed, and open windows. If the A/C compressor does not engage, test the compressor clutch control circuit and correct any failure. Refer to Group 8W, Wiring Diagrams.

(5) Open the suction valve to allow the remaining refrigerant to transfer to the system.

WARNING: TAKE CARE NOT TO OPEN THE DISCHARGE (HIGH-PRESSURE) VALVE AT THIS TIME.

(6) Close all valves and test the A/C system performance.

(7) Disconnect the charging station or manifold gauge set. Install the service port caps.

REFRIGERANT OIL LEVEL CHECK

When an air-conditioning system is first assembled, all components (except the compressor) are refrigerant oil free. After the system has been charged with (R134a) refrigerant and operated, the oil in the compressor is dispersed through the lines and components. The evaporator, condenser, and filter-drier will retain a significant amount of oil. (Refer to the Refrigerant Oil Capacities chart). When a component is replaced, the specified amount of refrigerant oil must be added. When the compressor is replaced, the amount of oil that is retained in the rest of the system must be drained from the replacement compres-

sor. When a refrigerant line or component has ruptured and has released an unknown amount of oil, the compressor should be removed and drained through the suction port. The filter-drier must be replaced along with the ruptured part. The oil capacity of the system, minus the amount of oil still in the remaining components, can be measured and poured into the suction port of the compressor.

Example: On a dual system the evaporator retains 60 ml (2 oz). The condenser retains 30 ml (1 oz) of oil, and system capacity may be 214 ml (7.25 oz) of oil.

$$214 \text{ ml} \text{ minus } 90 \text{ ml} = 124 \text{ ml (4.25 oz).}$$

REFRIGERANT OIL CAPACITIES

Refrigerant Oil Capacities	Front A/C		Dual A/C	
	ml	oz	ml	oz
Compressor	142ml	4.73 oz	220 ml	7.4 oz
Filter-Drier	15 ml	.5 oz	30 ml	1 oz
Condenser	15 ml	.5 oz	30 ml	1 oz
Evaporator	30 ml	1 oz	60 ml	2 oz
Rear Evaporator	-	-	60 ml	2 oz

9324-35

CAUTION: The refrigerant oil used in a R-134a A/C system is unique. Use only oils which were designed to work with R-134a refrigerant.

VERIFY REFRIGERANT OIL LEVEL

- (1) Using a refrigerant recovery machine, remove refrigerant from the A/C system.
- (2) Remove refrigerant lines from A/C compressor.
- (3) Remove compressor from vehicle.
- (4) From suction port on top of compressor, drain refrigerant oil from compressor.
- (5) Add system capacity minus the capacity of components that have not been replaced through suction port on compressor. Refer to the Refrigerant Oil Capacity Chart.
- (6) Install compressor, connect refrigerant lines, evacuate, and charge refrigerant system.

COMPONENT SERVICE PROCEDURES

INDEX

	page		page
Air Distribution Duct	11	Evaporator Coil	20
Ambient Switch	11	Expansion Valve	20
Blower Motor and Wheel Assembly	11	Filter-Drier Assembly	21
Blower Motor Resistor Block	14	Heater A/C Unit Recondition	22
Blower Motor Wheel	14	Heater Core	24
Compressor	14	Heater Hoses	24
Compressor Clutch/Coil	16	Heater-A/C Unit Housing	22
Compressor High-Pressure Relief Valve	18	Low Pressure Cut-Off Switch	24
Condensate Drain Tube	18	Temperature Control Cable	25
Condenser Assembly	19	Vacuum Actuator—Fresh/Recirc Door	25
Defroster Ducts/Demister Ducts and Hoses	19	Vacuum Actuators—Mode Doors	25
Electronic Cycling Clutch Switch Combo Valve (ECCS)	19	Water Control Valve	26

AIR DISTRIBUTION DUCT

REMOVAL AND INSTALLATION

(1) Instrument panel assembly must be removed. Refer to Group 8E, Instrument Panel and Gauges.

(2) After instrument panel has been removed, separate the defroster/demister ducts from the air distribution duct.

(3) Remove the air distribution duct-to-instrument panel mounting screws (Fig. 1).

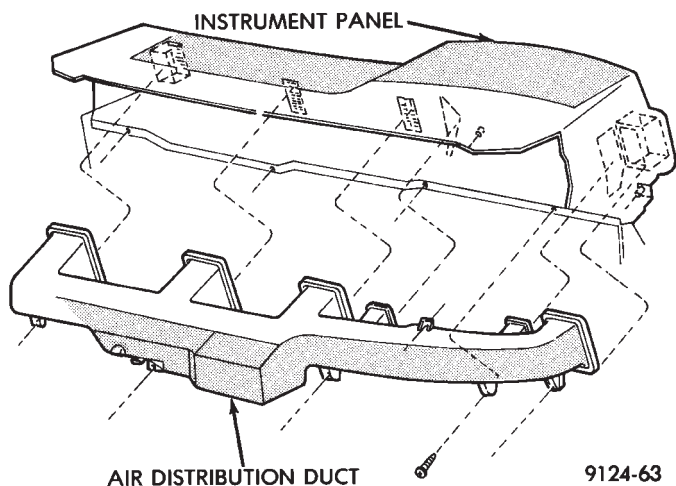

Fig. 1 Air Distribution Duct

AMBIENT SWITCH

The ambient switch is located in front of the condenser.

REMOVAL AND INSTALLATION

- (1) Disconnect the wiring connector.
- (2) Remove the mounting screw and the ambient temperature switch.

To install, reverse removal procedure.

BLOWER MOTOR AND WHEEL ASSEMBLY

VIBRATION AND/OR NOISE DIAGNOSIS

The blower speed switch, in conjunction with the resistor block (Fig. 2), supplies the blower motor with varied voltage.

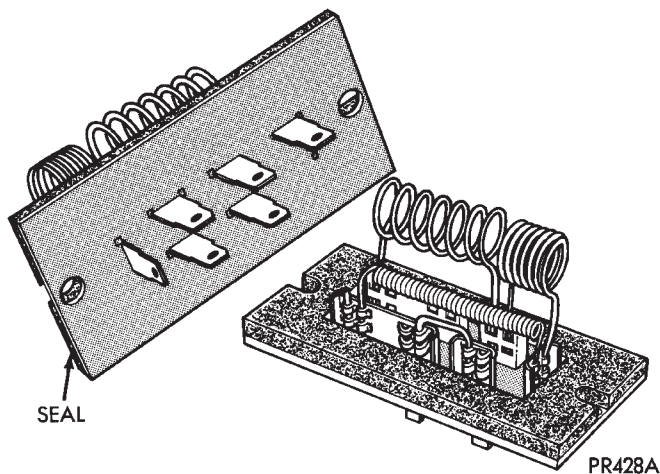

Fig. 2 Blower Motor Resistor Block—Typical

CAUTION: Stay clear of the blower motor and resistor block (Hot). Do not operate the blower motor with the resistor block removed from the heater-A/C housing.

Refer to the Blower Motor Vibration/Noise chart in this section for diagnosis.

ELECTRICAL DIAGNOSIS

Refer to the Blower Motor Electrical System Diagnosis chart in this section. Also refer to Group 8W, Wiring Diagrams for more information.

REMOVAL AND INSTALLATION

(1) To remove the blower motor, the lower right instrument panel assembly must be removed. Refer to



BLOWER MOTOR NOISE/VIBRATION DIAGNOSIS

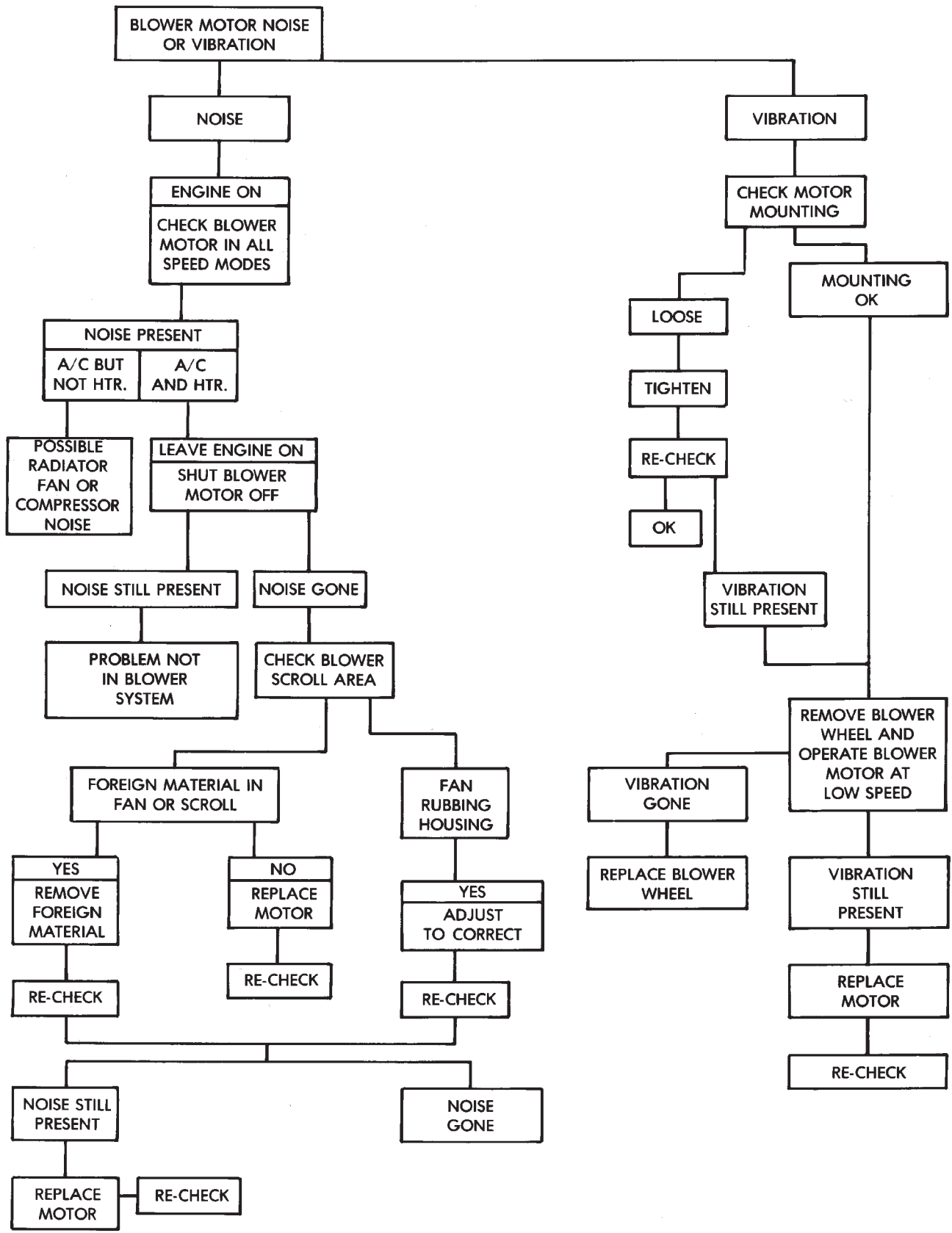

BLOWER MOTOR ELECTRICAL SYSTEM DIAGNOSIS

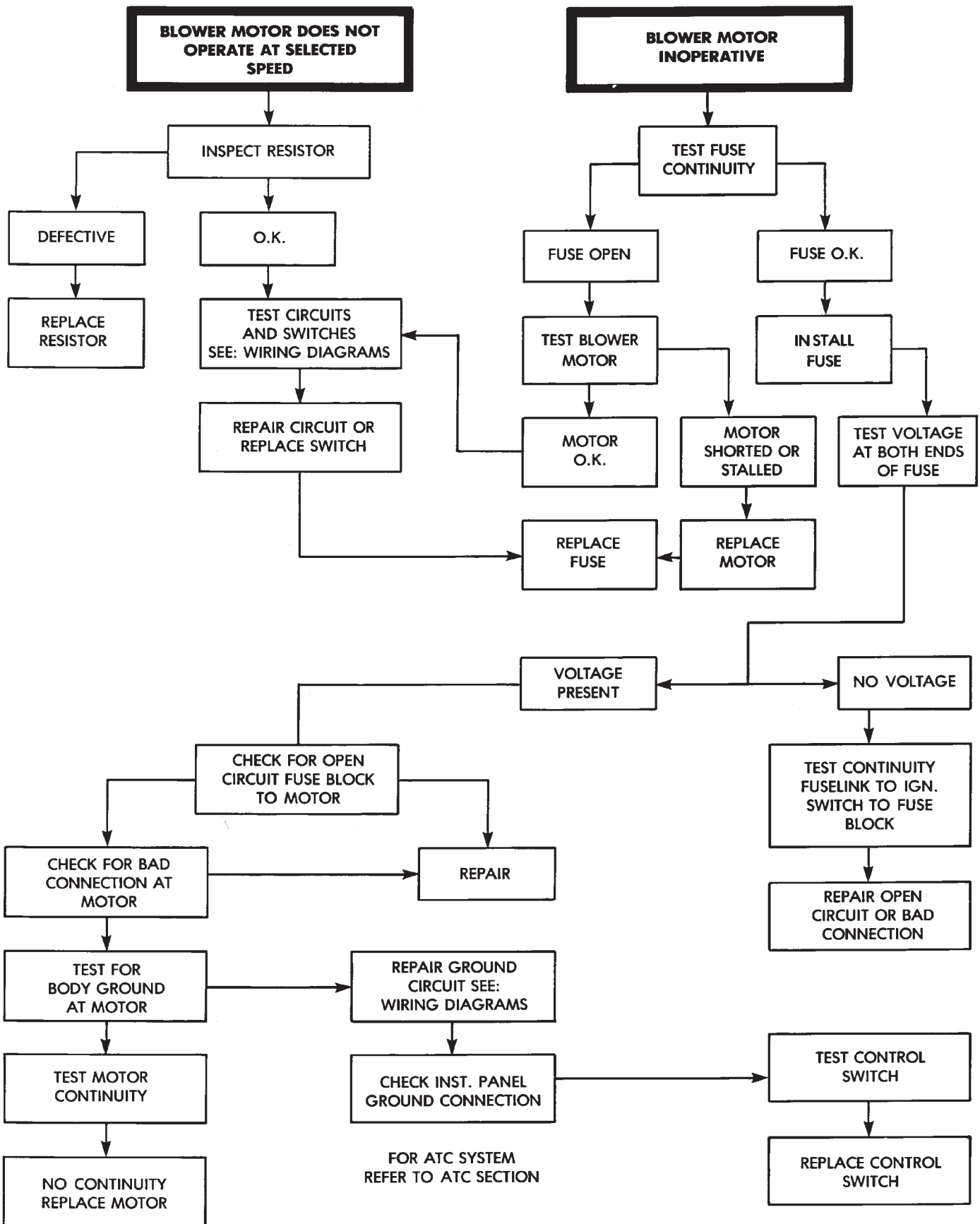

Group 8E, Instrument Panel and Gauges.

(2) Remove blower assembly-to-heater housing mounting screws.

(3) Allow the blower assembly to drop down, and remove assembly from vehicle.

To install, reverse the preceding operation.

BLOWER MOTOR RESISTOR BLOCK

REMOVAL AND INSTALLATION

(1) Open hood.

(2) Locate and remove the wire connector from the blower resistor block. Block is located at the back of the engine compartment on the passenger side of the vehicle (Fig. 3).

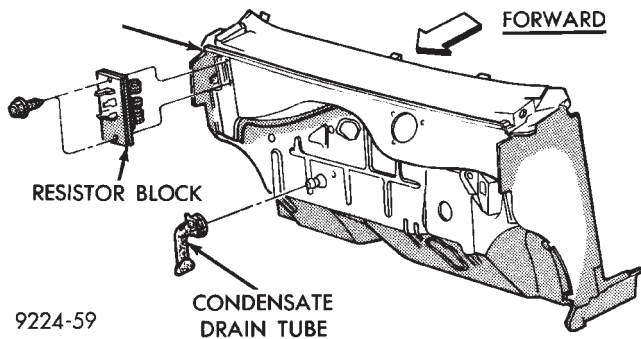

Fig. 3 Resistor Block Removal or Installation

(3) Remove resistor block attaching screws and pull the resistor block from the vehicle.

CAUTION: The resistor block may be hot and could cause burns.

To install, reverse the preceding operation. The coils on the Resistor Block should not be contacting one another. Before installation, gently separate the coils (with fingers only) if one coil is contacting another.

BLOWER MOTOR WHEEL

REMOVAL AND INSTALLATION

Blower motor must be removed from vehicle before performing this operation.

(1) Remove blower motor from vehicle.

(2) Remove the spring type retaining ring from the center of the blower wheel (Fig. 4). Note the location of the blower wheel on the blower motor shaft.

(3) Remove blower wheel from blower motor shaft.

To install, reverse the preceding operation. To prevent noise or vibration, rotate the blower wheel by hand to check for rubbing.

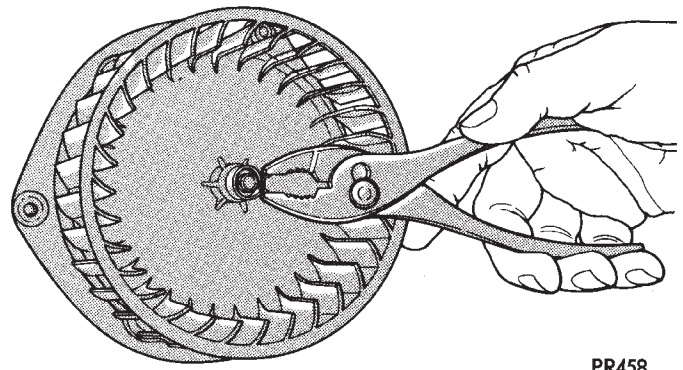

Fig. 4 Blower Wheel Retaining Ring Removal and Installation

COMPRESSOR

NOISE DIAGNOSIS

Excessive noise while the A/C is being used, can be caused by loose bolts, mounting brackets, loose clutch, or excessively high operating pressure. Verify compressor drive belt condition, proper refrigerant charge and head pressure before compressor repair is performed.

For noise diagnostic procedures, refer to the Compressor Noise and Compressor Clutch Diagnosis chart in this section.

OIL LEVEL

It is important to have the correct amount of oil in the A/C system to ensure proper lubrication of the compressor. Too little oil will result in damage to the compressor. Too much oil will reduce the cooling capacity of the system and consequently result in higher discharge air temperatures.

The oil used in the compressor is a PAG R134a refrigerant oil. Only refrigerant oil of the same type should be used to service the system. Do not use any other oil. The oil container should be kept tightly capped until it is ready for use, and then tightly capped after use to prevent contamination from dirt and moisture. Refrigerant oil will quickly absorb any moisture it comes in contact with. Special effort must be used to keep all R-134a system components capped to prevent moisture from entering the A/C system oil. Moisture in the oil is very difficult to remove and will cause a reliability problem with the compressor.

It will not be necessary to check oil level in the compressor or to add oil unless there has been an oil loss. This may be due to a ruptured line, shaft seal leakage, leakage from the evaporator, condenser leak, filter drier or loss of refrigerant due to a collision. Oil loss at a the leak point will be evident by the presence of a wet, shiny surface around the leak.

COMPRESSOR NOISE AND COMPRESSOR CLUTCH DIAGNOSIS

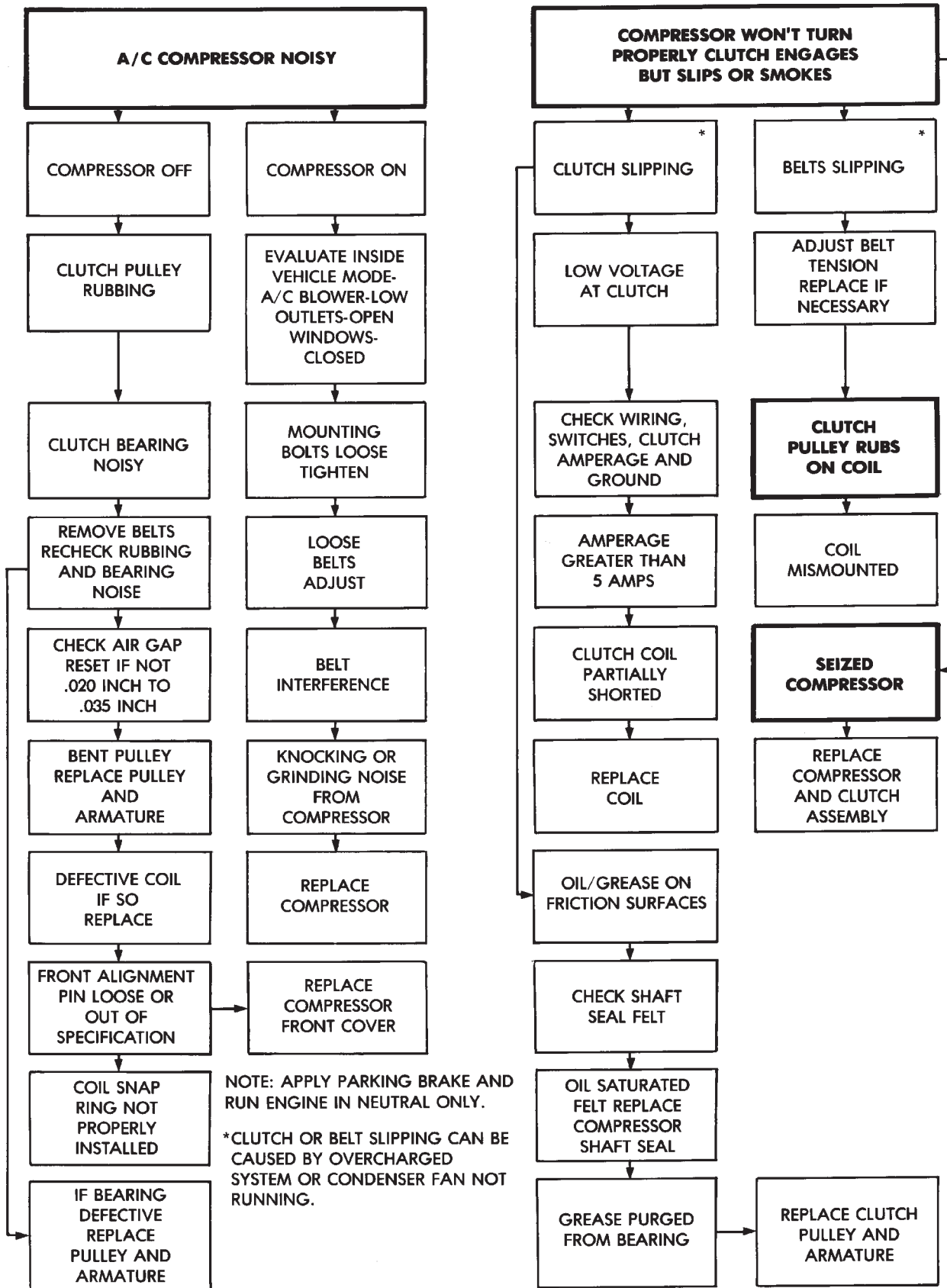

REMOVAL AND INSTALLATION

The A/C compressor may be removed and positioned without discharging the refrigerant system. Discharging is not necessary if removing the A/C compressor clutch/coil assembly, engine, cylinder head, or generator.

WARNING: REFRIGERANT PRESSURES REMAIN HIGH EVEN THOUGH THE ENGINE MAY BE TURNED OFF. BEFORE REMOVING A FULLY CHARGED COMPRESSOR, REVIEW THE SAFETY PRECAUTIONS AND WARNINGS SECTION IN THIS GROUP. DO NOT TWIST OR KINK THE REFRIGERANT LINES WHEN REMOVING A FULLY CHARGED COMPRESSOR. SAFETY GLASSES MUST BE WORN.

If the A/C compressor refrigerant lines will be removed for compressor removal. Refer to Discharging Refrigerant System in the Refrigerant Service Procedures section before proceeding with the following steps.

- (1) Disconnect negative battery cable.
- (2) Loosen and remove drive belts (refer to Group 7, Cooling System) and disconnect compressor clutch wire lead.
- (3) Remove refrigerant lines from compressor (if necessary).
- (4) Remove compressor attaching nuts and bolts.
- (5) Remove compressor. If refrigerant lines were not removed, lift compressor/clutch assembly and tie it to a suitable component.

To install, reverse the preceding operation.

COMPRESSOR CLUTCH/COIL

DIAGNOSIS

The air-conditioning compressor clutch electrical circuit is controlled by the powertrain control module. It is located in the engine compartment outboard of the battery.

If the compressor clutch does not engage verify refrigerant charge.

If the compressor clutch still does not engage check for battery voltage at the low pressure switch located on the expansion valve. If voltage is not detected, refer to:

- Group 8W, Wiring diagrams.
- The appropriate Powertrain Diagnostic Procedures manual for diagnostic information.

If voltage is detected at the cut-off switch, connect switch and check for battery voltage between the compressor clutch connector terminals.

If voltage is detected, perform A/C Clutch Coil Tests.

TESTS

(1) Verify battery state of charge. (Test indicator in battery should be green).

(2) Connect an ammeter (0-10 ampere scale) in series with the clutch coil terminal. Use a volt meter (0-20 volt scale) with clip leads measuring voltage across the battery and A/C clutch.

(3) With A/C control in A/C mode and blower at low speed, start the engine and run at normal idle.

(4) The A/C clutch should engage immediately and the clutch voltage should be within two volts of the battery voltage. If the A/C clutch does not engage, test the fusible link.

(5) The A/C clutch coil is acceptable if the current draw is 2.0 to 3.7 amperes at 11.5-12.5 volts at clutch coil. This is with the work area temperature at 21°C (70°F). If voltage is more than 12.5 volts, add electrical loads by turning on electrical accessories until voltage reads below 12.5 volts.

If coil current reads zero, the coil is open and should be replaced. If the ammeter reading is 4 amperes or more, the coil is shorted and should be replaced. If the coil voltage is not within two volts of the battery voltage, test clutch coil feed circuit for excessive voltage drop.

REMOVAL

Compressor assembly must be removed from mounting. Although, refrigerant removal is not necessary.

(1) Remove the compressor shaft bolt (Fig. 5). A band type oil filter removal tool can be placed around the clutch plate to aid in bolt removal.

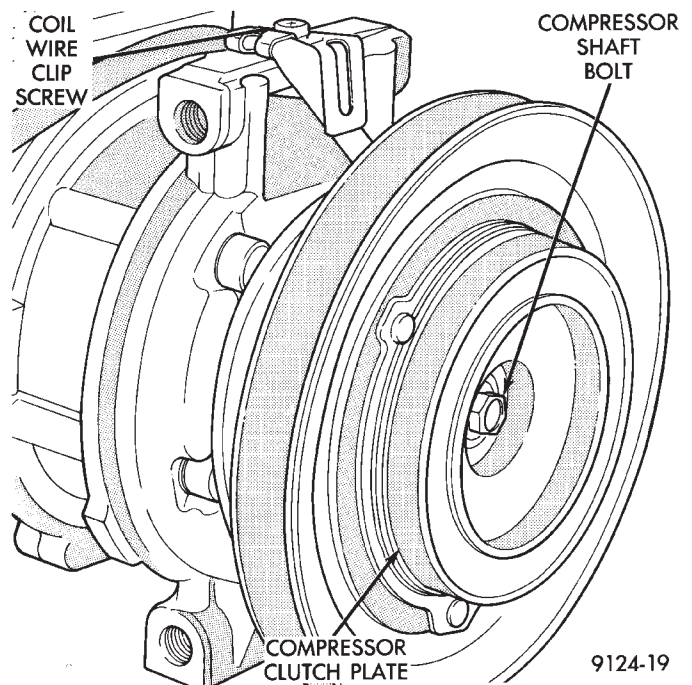

9124-19

Fig. 5 Compressor Shaft Bolt and Clutch Plate

CAUTION: Do not use screwdrivers between the clutch plate assembly and pulley to remove front plate as this may damage the front plate assembly.

(2) Tap the clutch plate with a plastic hammer and remove clutch plate and shim (Fig. 6).

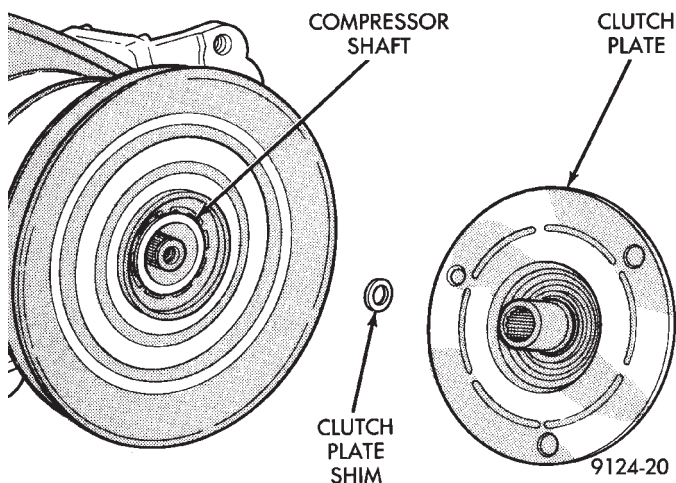

Fig. 6 Clutch Plate and Shim(s)

(3) Remove pulley retaining snap ring with snap ring pliers (C-4574), and slide pulley assembly off of compressor (Fig. 7).

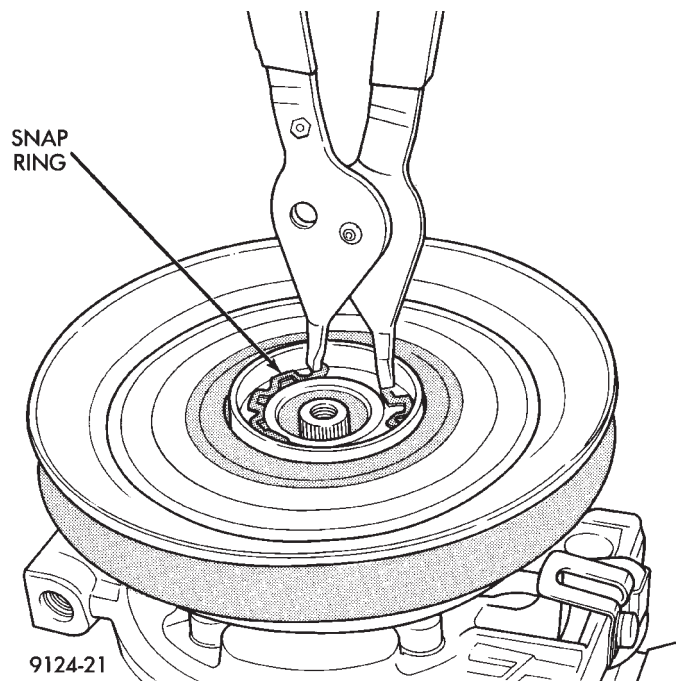

Fig. 7 Removing Pulley Snap Ring

(4) Remove coil wire clip screw and wire harness.

(5) Remove snap ring retaining field coil onto compressor housing (Fig. 8). Slide field coil off of compressor housing.

(6) Examine frictional faces of the clutch pulley and front plate for wear. The pulley and front plate should be replaced if there is excessive wear or scoring. If the friction surfaces are oily, inspect the shaft

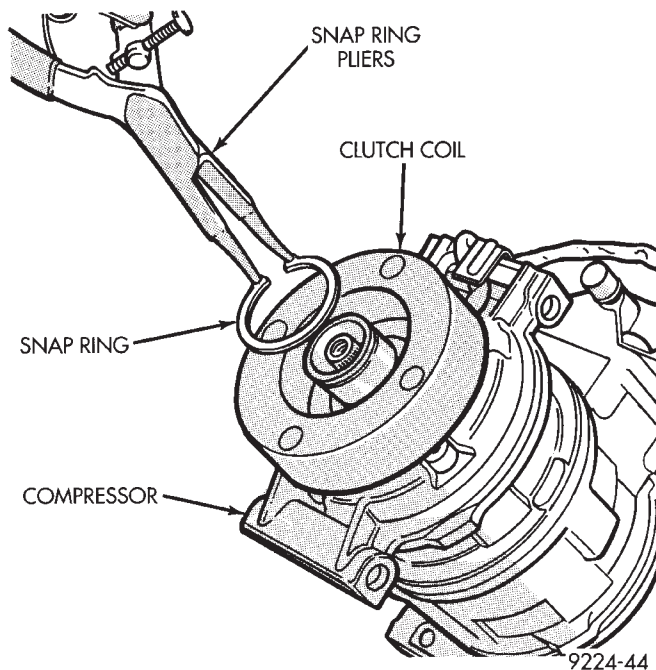

Fig. 8 Clutch Coil Snap Ring

nose area of the compressor for oil and remove the felt from the front cover. If the compressor felt is saturated with oil, the shaft seal is leaking and will have to be replaced.

(7) Check bearing for roughness, excessive leakage or grease. If grease from bearing has contaminated the faces of the pulley or front plate, they should be replaced. If the bearing is rough or binds, replace clutch pulley and front plate assembly.

CAUTION: The clutch pulley and the front plate were mated at the factory by a burnishing operation. No attempt should be made to separately replace either part. This will result in clutch slippage due to insufficient contact area.

INSTALLATION

(1) Align pin in back of field coil with hole in compressor end housing, and position field coil into place. Make sure that lead wires are properly routed, and fasten with the wire clip retaining screw.

(2) Install field coil retaining snap ring with snap ring pliers. The bevel side of the snap ring facing outward. Also both snap ring eyelets must be to the right or left of the pin on compressor. Press snap ring to make sure it is properly seated in the groove.

CAUTION: If snap ring is not fully seated it will vibrate out, resulting in a clutch failure and severe damage to the front face of the compressor.

(3) Install pulley assembly to compressor. If necessary, tap gently with a block of wood on the friction surface (Fig. 9).

CAUTION: Do not mar the pulley frictional surface.

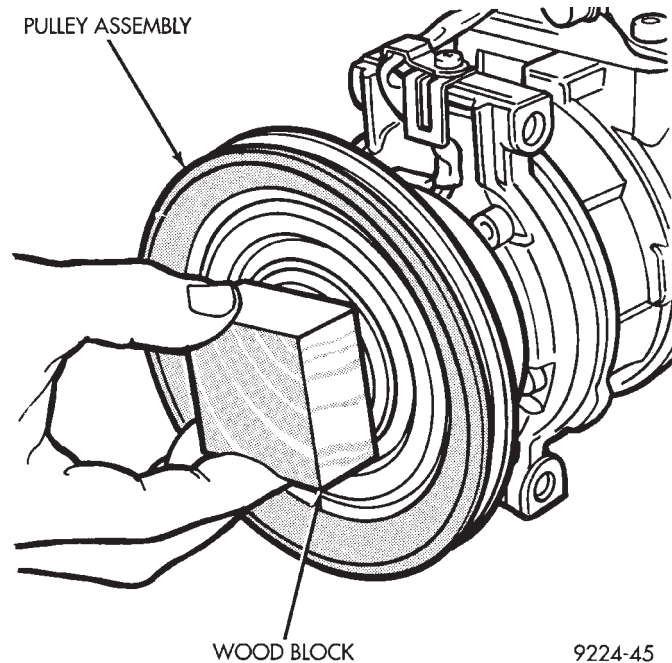

Fig. 9 Installing Pulley Assembly

(4) Install pulley assembly retaining snap ring (bevel side outward) with snap ring pliers. Press the snap ring to make sure it is properly seated in the groove.

(5) If the original front plate assembly and pulley assembly are to be reused, the old shim(s) can be used. If not, place a trial stack of shims, 1 mm (0.040 in.) thick, on the shaft against the shoulder.

(6) Install front plate assembly onto shaft.

(7) With the front plate assembly tight against the shim(s), measure the air gap between front plate and pulley face with feeler gauges. The air gap should be between 0.5 and 0.9 mm (.020 and .035 inch) If proper air gap is not obtained, add or subtract shims until desired air gap is obtained.

(8) Install compressor shaft bolt. Tighten to 17.5 ± 2 Nm (155 ± 20 in. lbs.).

Shims may compress after tightening shaft nut. Check air gap in four or more places to verify if air gap is still correct. Spin pulley for final check.

CLUTCH BREAK-IN

After a new clutch has been installed, check the voltage and amperage to the clutch (determine it to be satisfactory). Then cycle the A/C clutch approximately 20 times (5 sec. on and 5 sec. off). For this procedure, set the system to the A/C mode, using high blower, and engine rpm at 1500-2000. This procedure (burnishing) will seat the opposing friction surfaces and provide a higher clutch torque capability.

COMPRESSOR HIGH-PRESSURE RELIEF VALVE

The High Pressure Relief Valve (HPR) prevents damage to the air-conditioning system if excessive pressure develops. Excessive pressure can be caused by condenser air flow blockage, refrigerant overcharge, or air and moisture in the system.

The high pressure relief valve vents only a small amount of refrigerant necessary to reduce system pressure and then reseats itself. The majority of the refrigerant is conserved in the system. The valve is calibrated to vent at a pressure of 3100 to 4140 Kpa (450 to 600 psi). If a valve has vented a small amount of refrigerant, it does not necessarily mean the valve is defective.

The High Pressure Relief Valve is located on the discharge line at the A/C compressor.

Special effort must be used to keep all R-134a system components capped to prevent moisture from entering the A/C system oil. Moisture in the oil is very difficult to remove and will cause a reliability problem with the compressor.

REMOVAL AND INSTALLATION

(1) Using a refrigerant recovery machine, remove refrigerant from the A/C system.

(2) Rotate the high pressure relief valve counterclockwise and separate relief valve from the vehicle.

To install, Reverse the preceding operation using a new O-ring seal. Evacuate and charge the refrigerant system.

CONDENSATE DRAIN TUBE

Condensation that accumulates on the bottom of the evaporator housing is drained from a rubber tube through the dash panel and on to the ground. This tube must be kept open to prevent condensate water from collecting in the bottom of the heater A/C unit housing.

The tapered end of the drain tube is designed to keep contaminants from entering the heater A/C unit housing. If the tube is pinched or blocked, condensate cannot drain, causing water to back up and spill into the passenger compartment. It is normal to see condensate drainage below the vehicle. If the tube is damaged, it should be replaced.

REMOVAL AND INSTALLATION

(1) Raise vehicle.

(2) Locate rubber Drain Tube on right side of dash panel (Fig. 1).

(3) Squeeze clamp and remove drain tube.

To install, reverse the preceding operation. Check the drain tube nipple on the heater-A/C housing for any obstructions. The tube should be positioned downward and 45 degrees outboard.

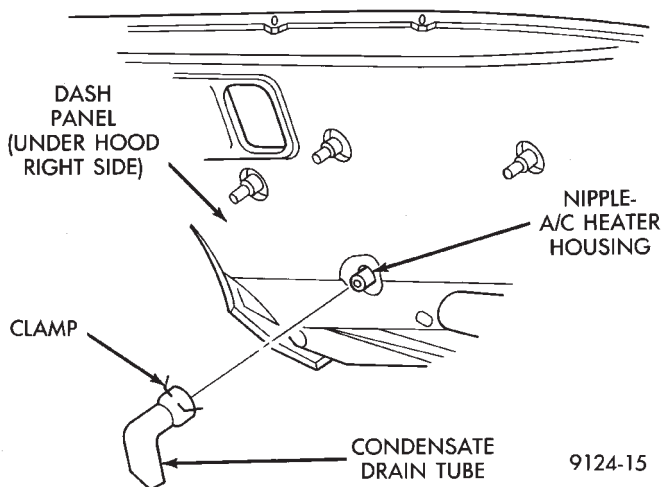

Fig. 1 Condensate Water Drain Tube—Typical

CONDENSER ASSEMBLY

WARNING: THE REFRIGERATION SYSTEM MUST BE COMPLETELY EMPTY BEFORE PROCEEDING WITH THIS OPERATION.

Special effort must be used to keep all R-134a system components capped to prevent moisture from entering the A/C system oil. Moisture in the oil is very difficult to remove and will cause a reliability problem with the compressor.

REMOVAL AND INSTALLATION

- (1) Disconnect condenser to drier line at condenser side.
- (2) Remove radiator fan and shroud assembly.
- (3) Remove condenser outlet to radiator bracket.
- (4) Remove grill assembly. Refer to Group 23, Body.
- (5) Remove core support center brace.
- (6) Remove auxiliary transmission oil cooler, if equipped.
- (7) Remove right side headlamp assembly. Refer to group 8L of this manual for detailed headlamp removal instructions.
- (8) Remove core support plastic panel.
- (9) Remove condenser mounting bolts.
- (10) Remove condenser from vehicle.

To install, replace all O-rings and gaskets, coat all sealing surfaces with approved wax-free refrigerant oil. Then reverse the preceding operation.

Evacuate and recharge system.

DEFROSTER DUCTS/DEMISTER DUCTS AND HOSES

REMOVAL AND INSTALLATION

- (1) Instrument panel assembly must be removed. Refer to group 8E, Instrument Panel and Gauges.
- (2) After instrument panel has been removed, separate the defroster/demister ducts from the air distribution duct.
- (3) Remove the demister tubes and hoses (Fig. 2).

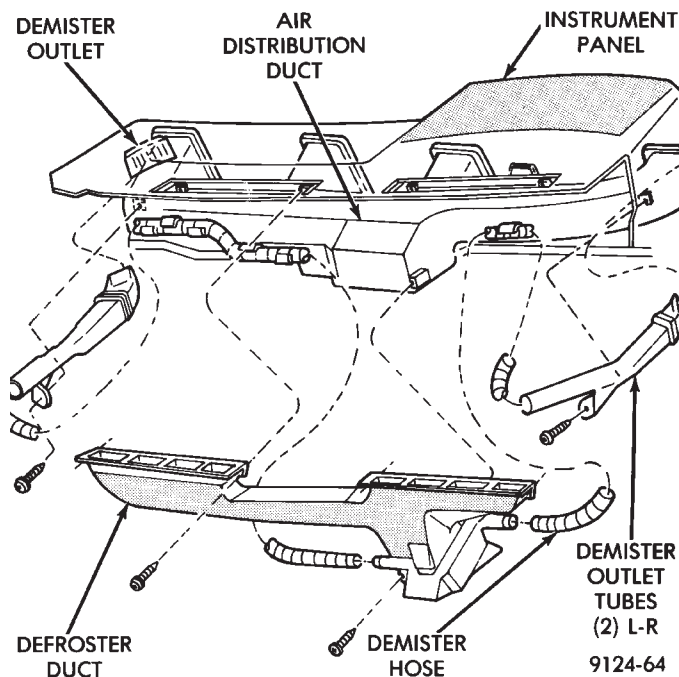

Fig. 2 Defroster Ducts/Demister Ducts and Hoses

ELECTRONIC CYCLING CLUTCH SWITCH COMBO VALVE (ECCS)

The Electronic Cycling Clutch Switch (ECCS) is located on the A/C expansion valve (Fig. 3). The ECCS prevents evaporator freeze-up by signaling the Powertrain Control Module to cycle the compressor ON and OFF. The ECCS monitors the temperature of the refrigerant after expansion.

ELECTRONIC CYCLING CLUTCH SWITCH

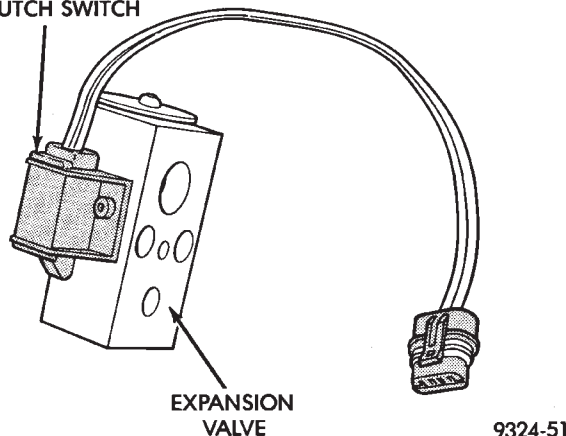
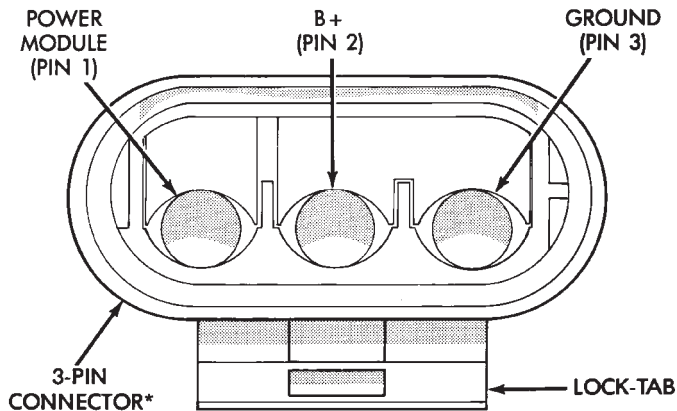

Fig. 3 Electronic Cycling Clutch Switch on Combination Expansion Valve

The ECCS uses a thermistor probe in a capillary tube. This is inserted into the well in the side of the expansion valve. The well must be filled with conductive grease to prevent corrosion and allow thermal transfer to the probe. The ECCS is a sealed unit and cannot be adjusted or repaired. It must be replaced if found defective.

TEST PROCEDURE

The ambient temperature in the test area should be approximately 21 C. (70 F.) while testing. Supply +12 (± 1) volts to pin 2 of the 3 pin ECCS connector (Fig. 4). Ground pin 3, and connect the output, pin 1, through a 390 ohm resistance to the +12 volt supply (Fig. 5). Do not connect pin 1 directly to the +12 volt supply. The voltage measured at the output (pin 1), when referenced to switch ground should be 0.75 volts or less. If the voltage at pin 1 exceeds 0.75 volts, replace the ECCS.



*VIEWED FROM CONNECTOR SIDE

9324-82

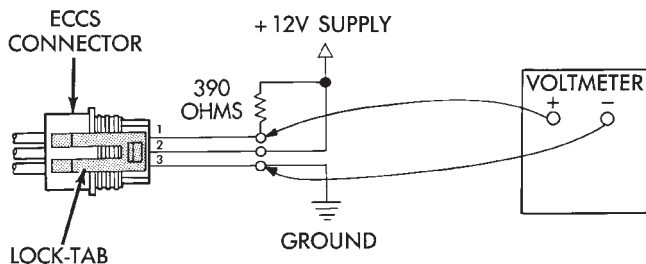
Fig. 4 ECCS Connector

9324-83

Fig. 5 ECCS Connector**REMOVAL AND INSTALLATION**

- (1) Disconnect the 3 pin connector at the ECCS.
- (2) Remove 4 mm hex bolt from side of expansion valve.
- (3) Slip the capillary tube from the well on the expansion valve. **The capillary-tube-well is filled with a special temperature conductive grease. Save this special grease and re-use it when installing the new switch.**

To install, reverse the preceding operation.

EVAPORATOR COIL

Special effort must be used to keep all R-134a system components capped to prevent moisture from entering the A/C system oil. Moisture in the

oil is very difficult to remove and will cause a reliability problem with the compressor.

REMOVAL AND INSTALLATION

Refer to Heater A/C Unit Recondition in this Group.

EXPANSION VALVE

Special effort must be used to keep all R-134a system components capped to prevent moisture from entering the A/C system oil. Moisture in the oil is very difficult to remove and will cause a reliability problem with the compressor.

TESTS

Expansion valve tests should be performed after compressor tests.

Review Safety Precautions and Warnings in the General Information section of this Group. The work area and vehicle temperature must be 21°C to 27°C (70°F to 85°F) when testing expansion valve. To test the expansion valve:

Liquid CO₂ is required to test the expansion valve. It is available from most welding supply facilities. CO₂ is also available from companies which service and sell fire extinguishers.

(1) Connect a charging station or manifold gauge set to the refrigerant system service ports. Verify the refrigerant charge level using the sight glass method.

(2) Disconnect and plug the vacuum line at the water control valve.

(3) Disconnect wire connector at low pressure cut-off switch (Fig. 1). Using a jumper wire, jump terminals inside wire connector boot.

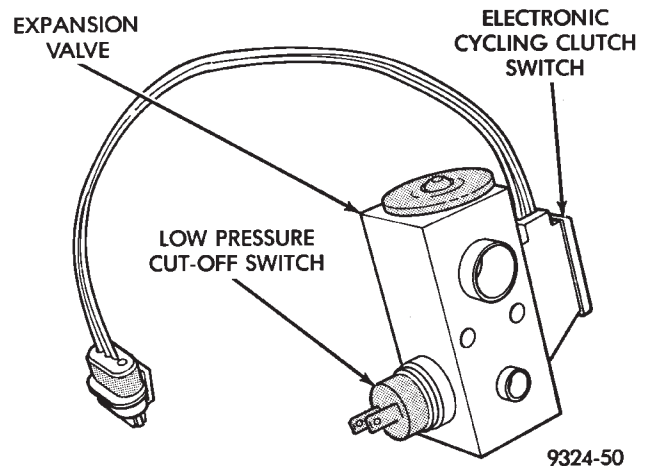

9324-50

Fig. 1 Low Pressure Cut-Off Switch

(4) Close all doors, windows and vents to the passenger compartment.

(5) Set heater-A/C control to A/C, full heat, FLOOR, and high blower.

(6) Start the engine and allow to idle (1000 rpm). After the engine has reached running temperature, allow the passenger compartment to heat up. This will create the need for maximum refrigerant flow into the evaporator.

(7) If the refrigerant charge is sufficient, discharge (high pressure) gauge should read 965 to 1655 kPa (140 to 240 psi). Suction (low pressure) gauge should read 140 kPa to 207 kPa (20 psi to 30 psi). If system cannot achieve proper pressure readings, replace the expansion valve. If pressure is correct, proceed with test.

WARNING: PROTECT SKIN AND EYES FROM CONTACTING CO₂—PERSONAL INJURY CAN RESULT.

(8) If suction side low pressure is within specified range, freeze the expansion valve control head (Fig. 2) for 30 seconds. Use a super cold substance (liquid CO₂). **Do not spray R-12 Refrigerant on the expansion valve for this test.** Suction side low pressure should drop to -50 kPa (-15 in. Hg) If not, replace expansion valve.

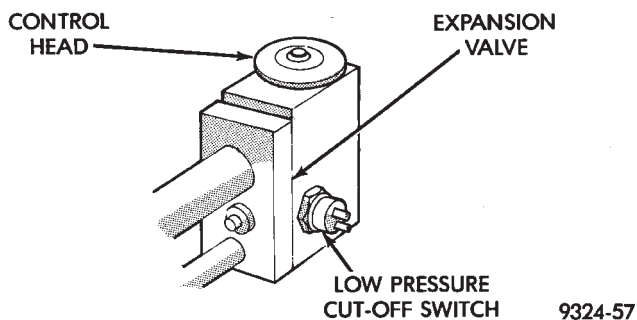

Fig. 2 Expansion Valve

(9) Allow expansion valve to thaw. The low pressure gauge reading should stabilize at 140 kPa to 240 kPa (20 psi to 30 psi). If not, replace expansion valve.

When expansion valve test is complete, test A/C overall performance. Remove all test equipment before returning vehicle to use.

REMOVAL

WARNING: THE REFRIGERATION SYSTEM MUST BE COMPLETELY EMPTY BEFORE PROCEEDING WITH THIS OPERATION.

- (1) Remove the boot-type wire connector from the pressure cut-off switch.
- (2) Remove the 3 pin connector from the ECCS.
- (3) Remove the attaching bolt in center of refrigerant line-plumbing sealing plate (Fig. 3).

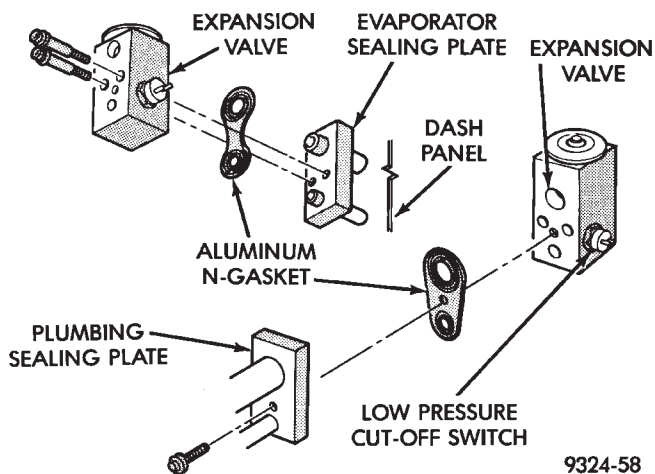

Fig. 3 Expansion Valve

(4) Carefully pull the refrigerant line-sealing plate assembly from the expansion valve towards front of vehicle. Do not scratch the expansion valve sealing surfaces with pilot tubes.

(5) Cover the openings on refrigeration line-sealing plate assembly to prevent dirt or moisture contamination.

(6) Remove two screws securing the expansion valve to the evaporator sealing plate.

(7) Carefully remove valve.

INSTALLATION

(1) Remove and replace the aluminum gasket on the evaporator sealing plate.

(2) Carefully hold the expansion valve to the evaporator sealing plate (do not scratch sealing surface). Install two attaching screws and tighten to $11 \pm 3 \text{ Nm}$ ($100 \pm 30 \text{ in. lbs.}$).

(3) Remove and replace the aluminum gasket on the refrigerant line-sealing plate assembly.

(4) Carefully hold the refrigerant line-sealing plate assembly

to the expansion valve, install bolt and tighten to $23 \pm 3 \text{ Nm}$

($200 \pm 30 \text{ inch lbs.}$).

(5) Connect wires to low pressure cut-off switch and the ECCS.

(6) Evacuate and recharge system.

(7) After expansion valve is installed, system is charged, and leaks have been checked, repeat A/C performance check.

FILTER-DRIER ASSEMBLY

CAUTION: The filter/drier used in a 134a refrigerant system will not interchange with a filter/drier from a R-12 refrigerant system.

Special effort must be used to keep all R-134a system components capped to prevent moisture from entering the A/C system oil. Moisture in the

oil is very difficult to remove and will cause a reliability problem with the compressor.

REMOVAL AND INSTALLATION

WARNING: THE REFRIGERATION SYSTEM MUST BE COMPLETELY EMPTY BEFORE PROCEEDING WITH THIS OPERATION.

- (1) Remove the vehicle jack.
- (2) Remove three mounting bolts from the filter-drier.
- (3) Remove the two high pressure refrigerant lines from the sides of the filter-drier assembly (Fig. 4). Then carefully separate lines from filter-drier. Discard the old gaskets.

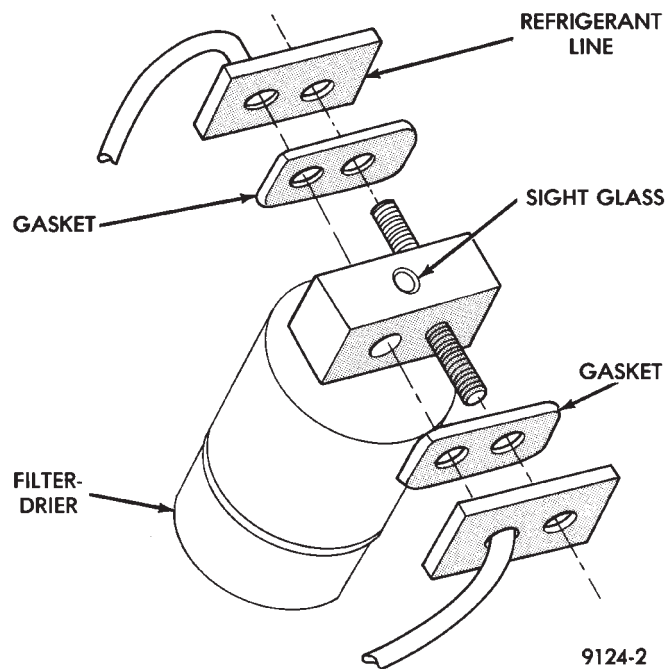

Fig. 4 Filter-Drier—Typical

- (4) Cover the open ends of the refrigerant lines to minimize refrigerant system contamination.

To install, replace both refrigerant line-to-filter-drier gaskets. Then reverse the preceding operation.

Evacuate and recharge system.

HEATER-A/C UNIT HOUSING

Special effort must be used to keep all R-134a system components capped to prevent moisture from entering the A/C system oil. Moisture in the oil is very difficult to remove and will cause a reliability problem with the compressor.

REMOVAL AND INSTALLATION

WARNING: IF EQUIPPED WITH AIR CONDITIONING, THE REFRIGERATION SYSTEM MUST BE COMPLETELY EMPTY BEFORE PROCEEDING WITH THIS OPERATION.

- (1) Set parking brake.

- (2) Disconnect negative battery cable.
- (3) Using a refrigerant recovery machine, remove refrigerant from the A/C system.
- (4) Disconnect all engine compartment lines and vacuum hoses.
- (5) Drain engine coolant. Plug coolant lines.
- (6) Remove the steering column cover.
- (7) Remove the left under panel silencer.
- (8) Remove the right under panel silencer.
- (9) Remove the center bezel (clips to instrument panel).
- (10) Remove the accessory switch carrier.
- (11) Remove Heat-A/C controls.
- (12) Remove standard storage module.
- (13) Remove the right lower instrument panel.
- (14) Remove the right 40-way wiring bracket.
- (15) Remove the lower right reinforcement, body computer bracket, and mid-to-lower reinforcement as one assembly.

(16) Disconnect all necessary instrument panel wiring and temporarily route wiring out of the way.

(17) Disconnect the A/C unit hanger strap from the unit and temporarily re-position.

(18) Remove the rubber condensate drain tube (in engine compartment).

(19) Remove the four nuts (in the engine compartment) securing the unit to the dash panel.

(20) Pull the entire unit rearward until the studs on the unit clear the dash panel. Drop the unit down and pull it rearward to remove it from vehicle.

To install the assembly, reverse the preceding operation.

HEATER A/C UNIT RECONDITION

Heater-A/C Housing must be removed from vehicle before performing this operation. Refer to Heater-A/C Unit Housing—Removal and Installation.

DISASSEMBLY

- (1) Place heater/A/C unit assembly (Fig. 1) on workbench.

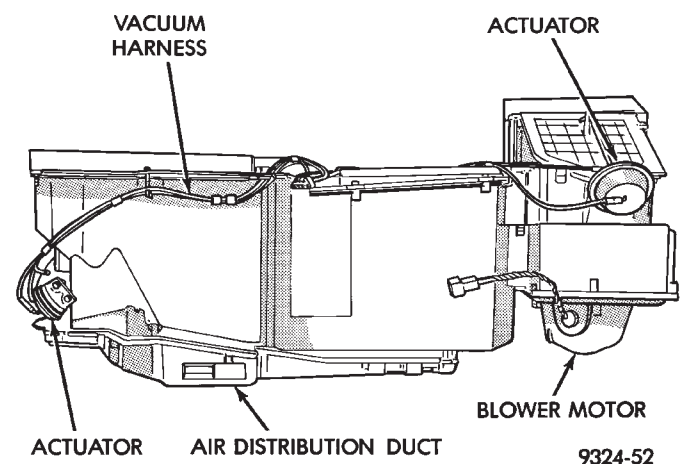

Fig. 1 Heater/Air Conditioning Assembly

(2) Remove one screw retaining the vacuum harness. Feed harness through hole in cover.

(3) Remove thirteen screws from top cover and remove cover. Temperature control door will come out with the cover. Remove the nut and lever from the door shaft to remove the temperature door from the cover.

(4) Remove screw from heater core tube retaining bracket and lift heater core out of unit (Fig. 2).

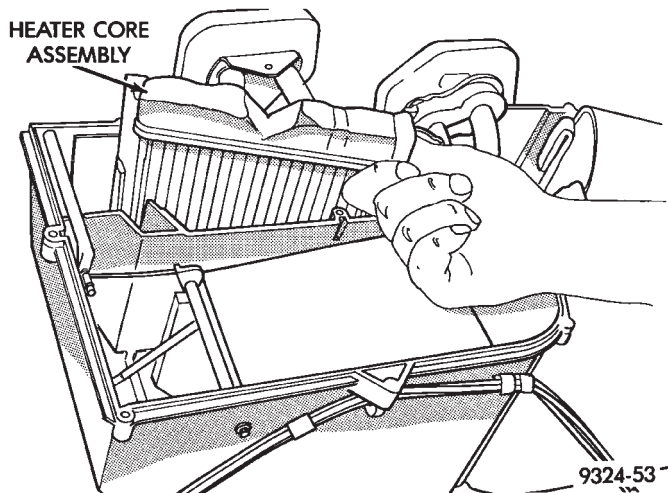

Fig. 2 Removing or Installing Heater Core Assembly

(5) Remove A/C evaporator coil out of unit (Fig. 3).

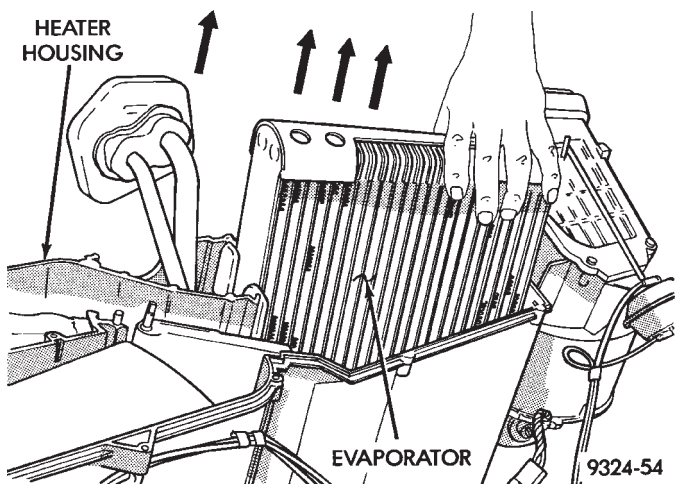

Fig. 3 Removing or Installing A/C Evaporator Coil

(6) Disconnect actuator linkage from fresh/recirculation door and vacuum lines from actuator. Loosen two nuts attaching actuator to housing and remove actuator (Fig. 4).

(7) Remove four screws attaching fresh/recirculation cover to unit and lift off cover (Fig. 5).

(8) Fresh/recirculating door may now be removed from its housing.

(9) To remove heat defrost door, remove retaining clip from shaft inside the housing. Pull shaft from housing and remove door.

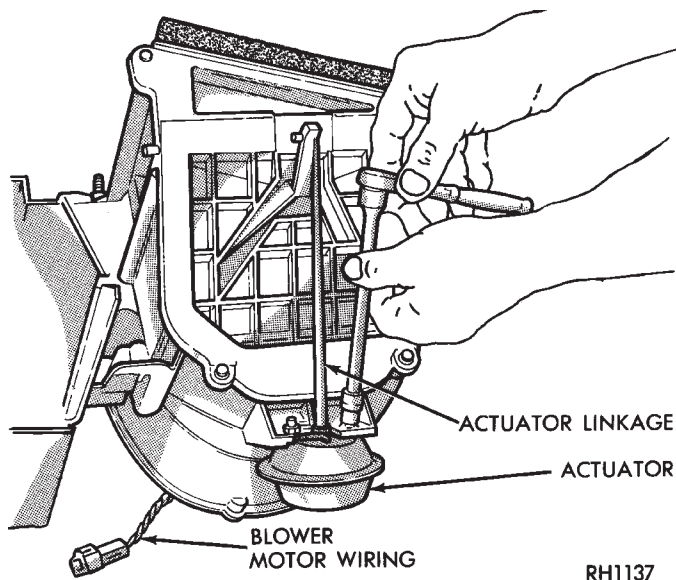

Fig. 4 Removing or Installing Fresh/Recirc Vacuum Actuator and Linkage

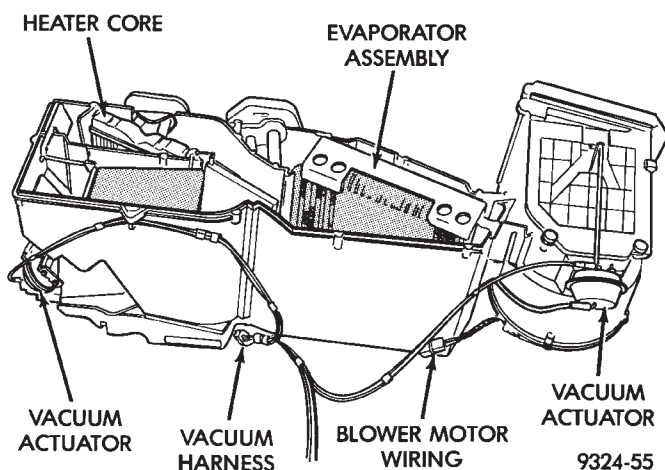

Fig. 5 Evaporator Heater Assembly

(10) To remove mode door, remove retaining clip from shaft inside the housing. Pull the shaft from the housing and remove door.

ASSEMBLY

(1) Place evaporator coil into unit.

(2) Place heater core into unit and fasten with screws.

(3) Reinstall blower wheel onto blower motor shaft and secure with retaining clamp.

(4) Feed blower motor wires through hole in housing. Lower blower assembly (rubber seal in place) into housing. Pull wiring grommet into place and install three mounting screws.

(5) Install blower motor assembly (five screws) to housing.

(6) Install fresh/recirculating door into housing. Install fresh/recirculating cover (four screws). Rotate

actuator shaft into door and slide actuator into bracket and tighten two nuts.

(7) To install mode door to housing, insert door shaft through housing and door pivot and demister spring. Push on shaft retainer (Fig. 6).

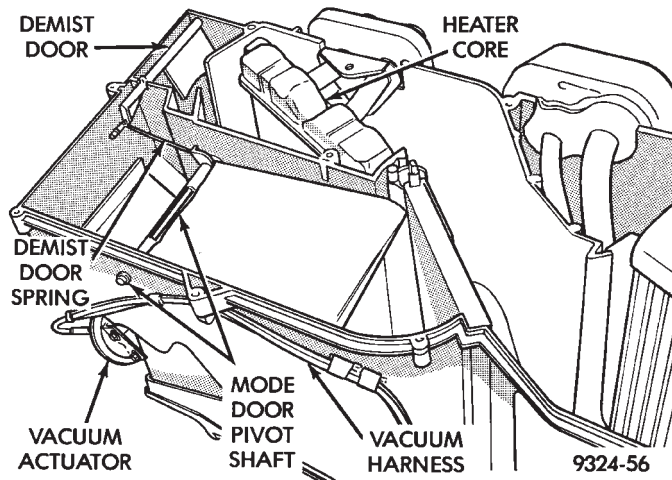

Fig. 6 Removing or Installing Mode Door Shaft

(8) To install demister door, connect wire spring to demister door. Insert pivot end of door into hole in housing. Position opposite into slot.

(9) To install heat/defrost door, insert door shaft through housing and door pivot. Push on shaft retainer.

(10) Install heat distribution duct to bottom of housing with three screws.

(11) To install temperature control door, install door shaft into lower pivot in the case housing. Place unit cover over housing while feeding temperature door shaft through cover. If the temperature control door is attached to the cover, feed the door into the housing with the cover. Direct the bottom pivot of the door with your hand through the mode door opening.

(12) To install housing cover, line up cover to housing using pilot pins, the temperature door, and screw holes for alignment. Install thirteen screws.

(13) Route vacuum harness through holes in cover. Install screw to retain vacuum harness. Make all vacuum hose attachments to vacuum actuators.

HEATER CORE

REMOVAL AND INSTALLATION

Refer to Heater A/C Unit Recondition in this Group.

HEATER HOSES

REMOVAL AND INSTALLATION

Review Safety Precautions and Warnings the in General Information section before proceeding with this operation.

(1) Drain engine cooling system. Refer to Group 7, Cooling System.

(2) Loosen clamps at each end of heater hose to be removed.

CAUTION: When removing hoses from heater core inlet or outlet nipples, do not use excessive force. Heater core may become damaged and leak engine coolant.

(3) Carefully rotate hose back and forth while tugging slightly away from connector nipple. If the hose will not come off, slice the hose at the connector nipple and peel off heater hose. This method will require heater hose replacement.

To install, reverse the preceding operation.

LOW PRESSURE CUT-OFF SWITCH

The Low Pressure Cut-Off (LPCO) Switch (Fig. 1) monitors the refrigerant gas pressure on the suction side of the system. The LPCO is located on the expansion valve, and the expansion valve is silver in color. The LPCO turns off voltage to the compressor clutch coil when refrigerant gas pressure drops to levels that could damage the compressor. The LPCO is a sealed factory calibrated unit. It must be replaced if defective.

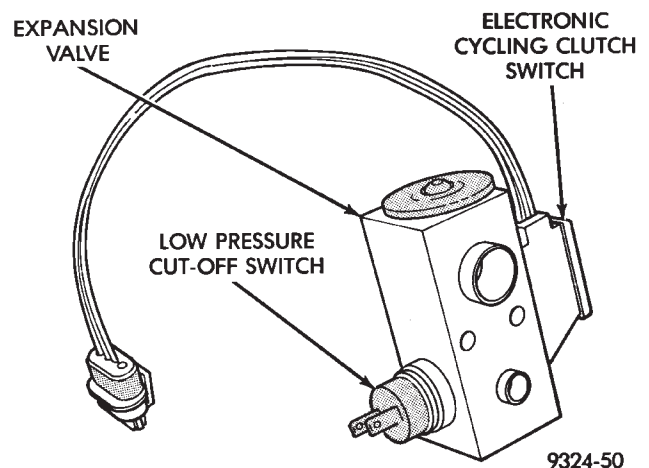

Fig. 1 Low Pressure Cut-Off Switch

TEST

The work area temperature must not be below 10°C (50°F) to test the compressor clutch circuit.

(1) With gear selector in park or neutral and park brake set, start engine and allow to idle.

(2) Raise hood and disconnect LPCO switch connector boot.

(3) Using a suitable jumper wire, jump across the terminals inside wire connector boot.

(4) If the compressor clutch does not engage, the cycling clutch switch, wiring, relay, or fuse can be defective. Refer to Group 8W, Wiring Diagrams.

(5) If clutch engages, connect manifold gauge set. Read low pressure gauge. At pressure above 97 kPa (14 psi) and above, LPCO switch will complete the clutch circuit. If the low pressure gauge reads below 172 kPa (25 psi), the system is low on refrigerant charge or empty due to a leak.

(6) Install connector boot on switch and repeat step number 3. If the clutch does not engage, replace the LPCO switch.

REMOVAL AND INSTALLATION

WARNING: THE REFRIGERATION SYSTEM MUST BE COMPLETELY EMPTY BEFORE PROCEEDING WITH THIS OPERATION.

(1) Disconnect the boot like wire connector at the cut-off switch.

(2) Using a sender unit type socket, remove the switch from the expansion valve.

To install, assure an adequate seal by using a small amount of thread sealing tape on the replacement switch and reverse the preceding steps.

Evacuate and charge the system.

TEMPERATURE CONTROL CABLE

REMOVAL AND INSTALLATION

(1) Remove heater-A/C control panel. Refer to Switch and Panel Component Service in Group 8E, Instrument Panel. Disconnect the attaching flag on the control cable from the heater-A/C control panel.

(2) Remove console assembly. Refer to Group 8E, Instrument Panel.

(3) Remove instrument panel lower steering column cover. Refer to Group 8E, Instrument Panel.

(4) Remove the right lower instrument panel/glove box door assembly. This assembly is clipped to the upper instrument panel at the right upper side.

(5) A/C equipped vehicles: From under the hood, disconnect the A/C suction line mounting bracket from the dash panel (above the expansion valve).

(6) From under the hood, loosen (do not remove) the four heater-A/C assembly to dash panel mounting nuts.

(7) From inside the vehicle: Remove the vertical (heater-A/C housing) support bracket (below the glove box).

(8) Tilt the entire heater-A/C housing assembly downward to gain access to the temperature cable.

(9) Locate and disconnect the attaching flag on the control cable at the heater-A/C housing (Fig. 2).

(10) Slip the cable self-adjusting clip from the blend-air door crank.

(11) Remove the cable from the vehicle.

(12) Removing the self-adjusting clip from cable (Fig. 2). Insert a 3/16 inch (4 mm) diameter tool (drill

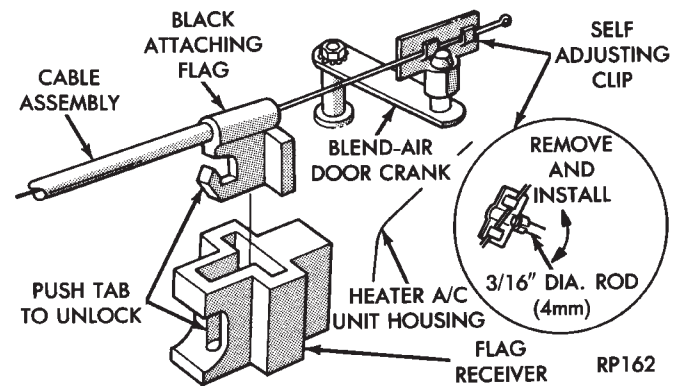

Fig. 2 Temperature Control Cable—Typical

bit or phillips screw driver shank) into the door crank access hole. Then rotate the clip from the cable.

To install, reverse the preceding operation.

To adjust temperature cable: Position the TEMP lever on the control to the cool side of its travel. Allowing the self-adjusting clip to slide on the cable, rotate the blend-air door crank counterclockwise by hand until it stops.

VACUUM ACTUATOR—FRESH/RECIRC DOOR

The Vacuum Actuator for the Fresh/Recirc Door is located on the passenger side of the heater-A/C housing.

REMOVAL AND INSTALLATION

(1) Remove heater-A/C control panel. Refer to Switch and Panel Component Service in Group 8E, Instrument Panel.

(2) Remove console assembly. Refer to Group 8E, Instrument Panel.

(3) Remove instrument panel lower steering column cover. Refer to Group 8E, Instrument Panel.

(4) Remove the right lower instrument panel/glove box door assembly. This assembly is clipped to the upper instrument panel at the right upper side.

(5) Remove vacuum lines from actuator.

(6) Loosen (do not remove) the two actuator attaching nuts (Fig. 3).

(7) Disengage actuator linkage at mode door.

(8) Remove actuator from vehicle.

To Install, Reverse the preceding operation.

VACUUM ACTUATORS—MODE DOORS

The Vacuum Actuators for the Mode Doors are located on the drivers side of heater/AC housing above the accelerator pedal.

REMOVAL

(1) Remove the instrument panel cover under the steering column. Refer to Group 8E, Instrument Panel and Gauges.

Heat/Defrost Actuator:

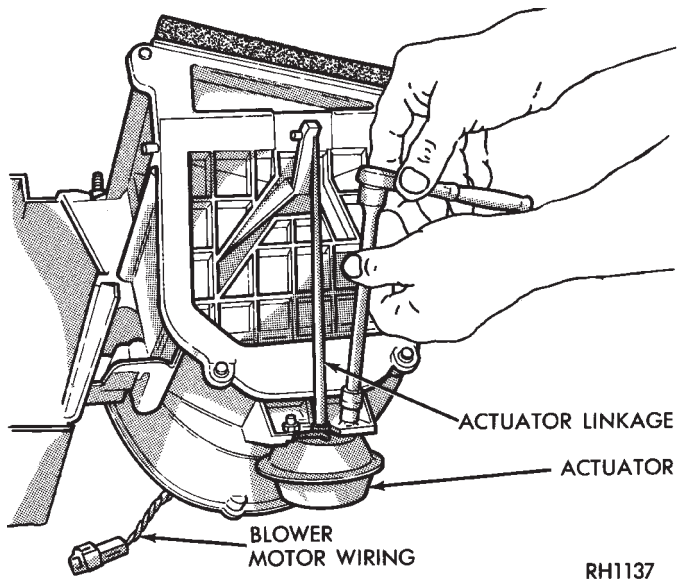

RH1137

Fig. 3 Removing or Installing Fresh/Recirc Vacuum Actuator

Remove two screws from bracket. Lift actuator upward and pull out (Fig. 4).

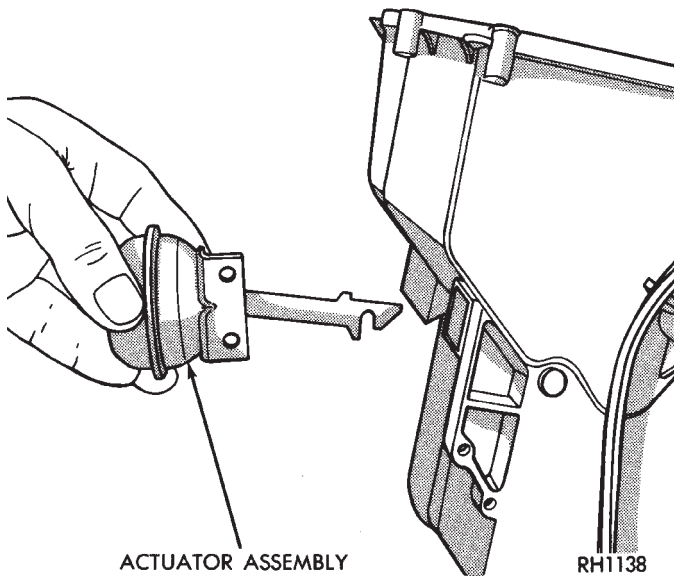

RH1138

Fig. 4 Removing or Installing Heat/Defrost Vacuum Actuator Assembly

Mode Door Actuator:

Remove two screws from bracket (Fig. 5). Rotate actuator counter-clockwise to unhook from door and pull to remove.

INSTALLATION

Heat/Defrost Actuator:

Install actuator link through housing and insert in heat defrost door slot. Push down to hook link to door. Locate the bracket to the housing and install two screws.

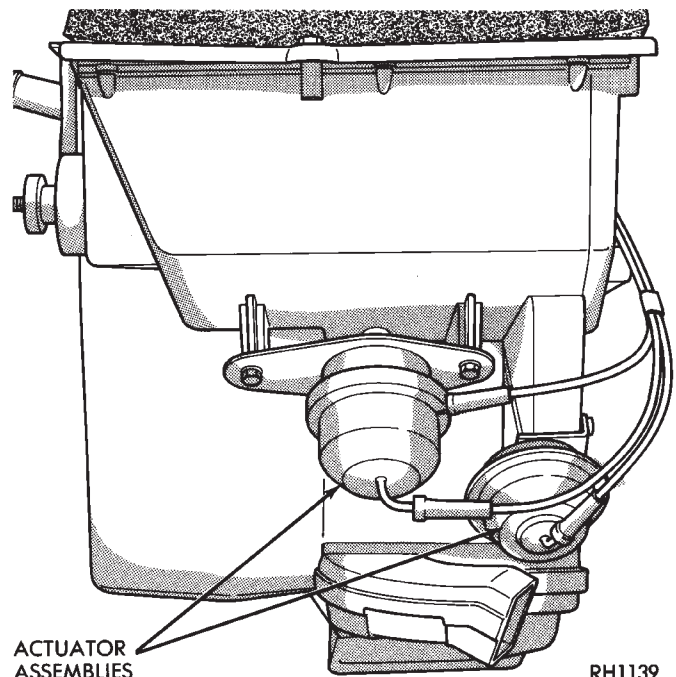

RH1139

Fig. 5 Mode Door Vacuum Actuators

Mode Door Actuator:

Insert the actuator shaft through the hole in the housing and heat/defrost door. Attach through mounting hole in the mode door. Install two screws in bracket.

Install the instrument panel cover under the steering column.

WATER CONTROL VALVE

REMOVAL AND INSTALLATION

- (1) Drain engine cooling system. Refer to Group 7, Cooling System.
- (2) Locate and loosen clamps at water control valve (Fig. 6).

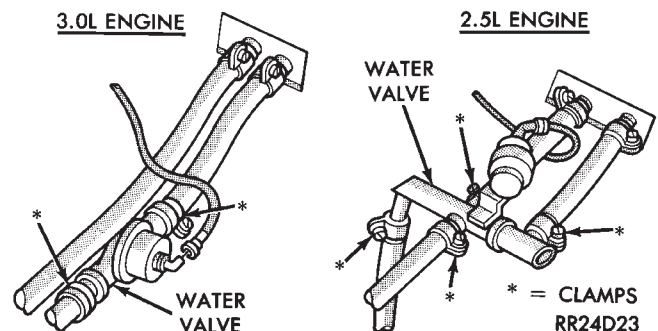

Fig. 6 Water Control Valve

- (3) Disconnect the vacuum line and heater hoses from water control valve (mark the heater hoses to assure correct valve installation).

To install, reverse the preceding operation.

AUXILIARY REAR HEATING OR HEATING-AIR/CONDITIONING

INDEX

	page		page
Air Distribution Duct	28	Rear Blower Resistor Block	28
Auxiliary Under Body Heater Plumbing	29	Rear Heater A/C Air Outlets	27
Auxiliary Under Body Refrigerant Plumbing	29	Rear Heater A/C Blower Motor	28
Diagnostic Procedures	27	Rear Heater A/C Control	27
Evaporator and Expansion Valve	28	Rear Heater A/C Control Illumination Bulb	27
General Information	27	Rear Heater-A/C Unit	28
Heater Core	28		

GENERAL INFORMATION

For proper operation of the rear heating-air/conditioning system, refer to the Owner's Manual supplied with the vehicle.

The auxiliary rear heater functions the same as the heater-A/C system. The rear heater utilizes the same components as the rear heater-A/C system. Only the refrigerant components have been omitted.

The auxiliary rear heating-air/conditioning system is located in the left rear quarter panel. It is a manually operated device, controlled by the rear-seat occupant. The rear heater A/C control operates in conjunction with the front heater A/C control. A four position blower (override) switch is located on the instrument panel (Fig. 1). The operator can use the rear heater-A/C blower instrument panel switch to operate the blower, regardless of the rear control setting. In the OFF position, the rear control will not function. In the ON position, the rear control will function normally.

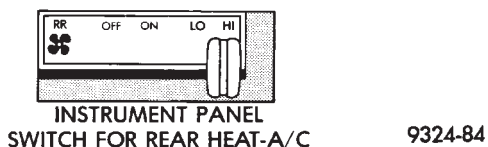
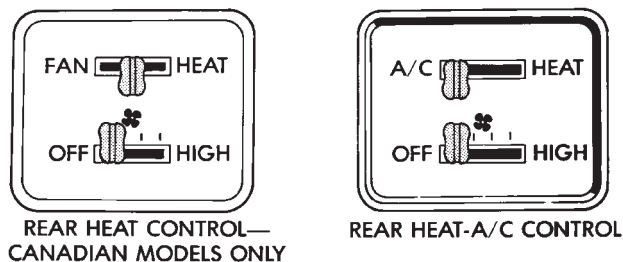

Fig. 1 Rear Heater, Rear Heater-A/C Controls

Air from inside the vehicle is drawn into the air intake grille in the left rear quarter trim panel. The air enters the blower and is pushed through the heater core and A/C evaporator coil (if equipped).

When the HEAT mode is selected, the airflow is directed from the heat outlets at the floor. When the FAN or A/C mode is selected, the airflow is directed from the upper air outlets.

DIAGNOSTIC PROCEDURES

When diagnosing electrical problems in the auxiliary rear heater or rear A/C system, refer to Group 8W, Wiring Diagrams.

When diagnosing mechanical problems in the auxiliary rear heater-A/C systems, refer to diagnostic sections for front heater-A/C.

REAR HEATER A/C CONTROL

REMOVE AND INSTALL

(1) Pry outward on the outside upper and lower corners of the control.

(2) Separate the control from the trim panel and disconnect the wire connectors.

To install, push the control into the opening until it locks into place.

REAR HEATER A/C CONTROL ILLUMINATION BULB

REMOVE AND INSTALL

(1) Remove rear heater A/C control from trim panel.

(2) On the back of control opposite from the wire connectors, locate the bulb socket lug.

(3) Rotate the socket counterclockwise and pull the socket from the control.

To install, reverse the preceding operation. Refer to the back of Group 8L, Lamps, for bulb usage.

REAR HEATER A/C AIR OUTLETS

REMOVAL AND INSTALL

(1) Pry outward on the outside upper and lower corners of the outlets.

(2) Separate the air outlet from the trim panel.

To install, push the outlet firmly into the opening until it locks into place.

REAR BLOWER RESISTOR BLOCK

REMOVE AND INSTALL

(1) Remove the left lower quarter trim panel. Refer to Group 23, Body.

(2) Disconnect wire connectors from resistor block.

(3) Remove two attaching screws from resistor block and separate from the heater-A/C unit.

To install, reverse the preceding operation.

REAR HEATER A/C BLOWER MOTOR

REMOVE AND INSTALL

(1) Remove the left lower quarter trim panel. Refer to Group 23, Body.

(2) Remove one blower cover to floor attaching screw and seven blower cover to unit attaching screws.

(3) Rotate blower cover from under heater-A/C unit cover.

(4) Compress the clamp at the center of the blower wheel and pull the wheel from the blower shaft.

(5) Remove three blower motor attaching screws.

(6) Separate the blower motor from the housing unit.

To install, reverse the preceding operation.

REAR HEATER-A/C UNIT

Special effort must be used to keep all R-134a system components capped to prevent moisture from entering the A/C system oil. Moisture in the oil is very difficult to remove and will cause a reliability problem with the compressor.

REMOVE AND INSTALL

WARNING: ON VEHICLES EQUIPPED WITH REAR A/C, THE REFRIGERANT SYSTEM MUST BE EMPTIED BEFORE PERFORMING THE FOLLOWING OPERATION. THE ENGINE COOLING SYSTEM MUST ALSO BE RELIEVED OF ALL PRESSURE.

(1) Drain engine cooling system. Refer to Group 7, Cooling System. Disconnect heater hoses at rear heater-A/C unit.

(2) Using a refrigerant recovery machine, remove refrigerant from the A/C system. Disconnect A/C plumbing from rear heater-A/C unit.

(3) Remove left lower quarter trim panel. Refer to Group 23, Body.

(4) Remove the attaching screws securing the air distribution duct to the rear wheel housing.

(5) Remove the attaching screws securing the heater unit to the floor pan.

(6) Remove attaching screw securing the unit to the quarter panel support.

(7) Lift the unit enough to clear the floor pan and remove the unit from the vehicle.

To Install, Reverse the preceding operation. Install new gaskets at refrigerant lines and expansion valve. Evacuate and charge the refrigerant system. Refill the cooling system. Test for leaks and overall performance.

AIR DISTRIBUTION DUCT

REMOVE AND INSTALL

(1) Remove left quarter trim panel. Refer to Group 23, Body.

(2) Remove the screws securing the A/C duct to the heater-A/C unit and the body.

(3) Pull the distribution duct straight up to remove.

To Install, Reverse the preceding operation.

HEATER CORE

REMOVE AND INSTALL

(1) Drain the engine coolant system.

(2) Disconnect heater tubing from the under body heater lines to the rear unit.

(3) Remove the lower left quarter trim panel. Refer to Group 23, Body.

(4) Remove fan-A/C distribution duct.

(5) Remove heater-unit cover.

(6) Carefully pull the heater core and heater tubes straight out of the unit.

(7) Raise the heater core to drain residual coolant from the core.

(8) Disconnect two heater hose clamps that attach plumbing to the heater core tube.

(9) To install, reverse the preceding operation.

EVAPORATOR AND EXPANSION VALVE

Special effort must be used to keep all R-134a system components capped to prevent moisture from entering the A/C system oil. Moisture in the oil is very difficult to remove and will cause a reliability problem with the compressor.

REMOVE

WARNING: THE REFRIGERANT SYSTEM MUST BE EMPTY BEFORE PERFORMING THE FOLLOWING OPERATION. THE ENGINE COOLING SYSTEM MUST ALSO BE RELIEVED OF ALL PRESSURE.

(1) Remove left quarter trim panel. Refer to Group 23, Body.

(2) Remove fan-A/C distribution duct.

(3) Remove rear A/C unit.

(4) Remove unit cover.

(5) Remove the bolt that mounts the unified refrigerant plumbing block to the expansion valve.

(6) Carefully pull the evaporator and expansion valve straight out of unit. Do not scratch the sealing surfaces with the plumbing extension tube pilots.

(7) Remove and discard the aluminum gasket between the plumbing extension and the expansion valve.

(8) Cover the plumbing extension sealing surface to prevent contamination.

(9) Bring evaporator and expansion valve to a clean work space.

(10) Remove two 1/4-20 Torx Head screws.

(11) Remove expansion valve.

(12) Measure and record the amount of residual oil from the removed evaporator.

INSTALL

(1) Replace the aluminum gaskets (one on evaporator plate and one on plumbing plate).

(2) Hold expansion valve against evaporator sealing plate (do not scratch the sealing surface). Install two screws and tighten to 100 ± 30 inch pounds (11 ± 3 N•m).

(3) Carefully install the evaporator and expansion valve straight into the unit. Do not scratch the sealing surfaces with the plumbing extension tube pilots.

(4) Determine the amount of old refrigerant oil drained from the evaporator. Add this amount (of clean refrigerant oil) back into the system.

(5) Carefully align the expansion valve onto the pilot tube of the plumbing sealing plate (do not scratch the sealing surface). Install the bolt through the plumbing plate into the unit sealing plate. Tighten bolts to 200 ± 30 inch pounds (23 ± 3 N•m).

(6) Install unit cover and air distribution duct.

(7) Install quarter trim panel, evacuate/charge system, and test performance.

AUXILIARY UNDER BODY HEATER PLUMBING

REMOVAL AND INSTALLATION

WARNING: THE ENGINE COOLING SYSTEM MUST BE RELIEVED OF ALL PRESSURE.

(1) Drain the engine cooling system. Refer to Group 7, Cooling System.

(2) In the engine compartment, disconnect two auxiliary rear heater hoses from the (front) heater hose tee fittings.

(3) Hoist the vehicle. Disconnect two push-together couplings from the auxiliary rear heater core tubes protruding through the floor pan.

(4) Remove four bolts and one pal nut holding the plumbing to the floor pan and lower the plumbing from the vehicle (Fig. 2).

To Install, Reverse the preceding operation.

AUXILIARY UNDER BODY REFRIGERANT PLUMBING

Special effort must be used to keep all R-134a system components capped to prevent moisture

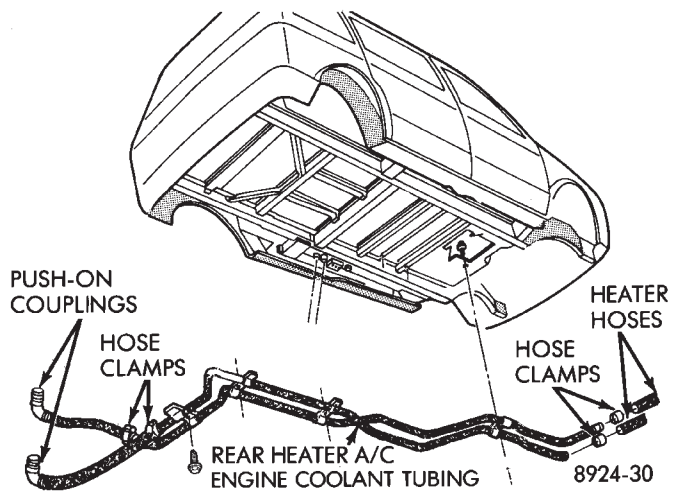

Fig. 2 Rear Heater Under body Plumbing

from entering the A/C system oil. Moisture in the oil is very difficult to remove and will cause a reliability problem with the compressor.

REMOVAL

WARNING: THE REFRIGERANT SYSTEM MUST BE EMPTY BEFORE PERFORMING THE FOLLOWING OPERATION.

(1) Hoist the vehicle. Disconnect two tube-fittings from the engine compartment plumbing.

(2) Remove the bolt from the unified plumbing block (left side of car, outboard of rail, forward of fuel tank).

(3) Carefully pull refrigerant line assembly down (take care NOT to scratch the sealing surface with the tube pilots). Remove and discard the aluminum gasket and cover unit sealing surface to prevent contamination.

(4) Remove two screws holding plumbing to the fuel tank support and left-side support rail (near muffler support bracket).

(5) Remove two screws holding the plumbing to the floor pan.

(6) Disconnect the parking brake system at hook above muffler and the cable connection near the support rails.

(7) Fish the nylon tubing and unified plumbing block above the muffler support member.

(8) Lower the plumbing from the vehicle.

(9) Measure the residual oil in the under body plumbing out of each end of the plumbing. The low-side (larger diameter line) has a check valve that can restrict oil flow from the tube-fitting to the unified plumbing end of the hose. Measure clean R134a PAG refrigerant oil to be returned to the refrigerant system.

INSTALL

(1) Protect the plumbing ends from scratches. If plumbing is new, do not remove the shipping caps until joining together.

(2) Reverse the preceding steps from the REMOVAL procedure.

(3) New gaskets and O-rings are required for installation. The O-rings must be covered with clean refrigerant oil prior to installation.

(4) Connect the tube-fittings to the engine compartment under body plumbing. Avoid misalignment of the threads (cross threading) and tighten to 200 in-lbs.

(5) Remove the shipping cap from the plumbing side sealing surface and verify that the aluminum gasket is present.

(6) Carefully align the pilot tubes of the plumbing line block into the unit (take care not to scratch the sealing surface).

(7) Install the bolt through the plumbing plate into

the unit sealing plate. Tighten bolt to 200 ± 30 inch pounds (23 ± 3 N•m) (Fig. 3).

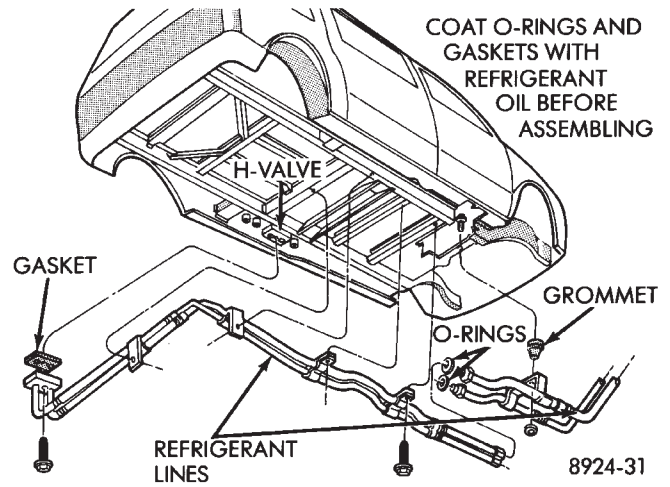

Fig. 3 Rear A/C Under body Plumbing