

WINDSHIELD WIPER AND WASHER SYSTEMS

CONTENTS

| | page | | page |
|--|------|---------------------------------------|------|
| INTERMITTENT WINDSHIELD WIPER MOTOR AND SWITCH | 8 | WINDSHIELD WASHERS | 9 |
| REAR WINDOW WIPER/WASHER SYSTEM ... | 11 | WINDSHIELD WIPER BLADE AND ARM | 1 |
| | | WINDSHIELD WIPER MOTOR AND LINKAGE .. | 4 |

WINDSHIELD WIPER BLADE AND ARM

INDEX

| | page | | page |
|-----------------------------|------|--|------|
| General Information | 1 | Wiper Blade Element Change Replacement | 1 |
| Wiper Arm Adjustment | 3 | Wiper Blades | 1 |
| Wiper Arm Replacement | 1 | | |

GENERAL INFORMATION

WARNING: ON VEHICLES EQUIPPED WITH AIRBAG, SEE GROUP 8M, RESTRAINT SYSTEMS FOR STEERING WHEEL OR COLUMN REMOVAL PROCEDURES.

The windshield wipers can be operated with the windshield wiper switch only when the ignition switch is in the ACCESSORY or IGNITION position. A fuse located in the fuse block protects the circuitry of the wiper system and the vehicle.

The wiper motor has permanent magnetic fields. The speeds are determined by current flow to the appropriate set of brushes.

The intermittent wipe system has a low and high speed with a delay mode. The delay mode has a range of 2 to 15 seconds. This is done by a variable resistor in wiper switch and is controlled electrically by a relay.

The wiper system completes the wipe cycle when the switch is turned OFF. The blades park in the lowest portion of the wipe pattern (Fig. 1).

WIPER BLADES

Wiper blades exposed to the weather for a long period of time tend to lose their wiping effectiveness. Periodic cleaning of the wiper blade is suggested to remove the accumulation of salt and road film. The wiper blades, arms and windshield should be cleaned with a sponge or cloth and a mild detergent or non-abrasive cleaner. If the blades continue to streak or smear, they should be replaced.

WIPER BLADE ELEMENT CHANGE REPLACEMENT

(1) Turn wiper switch ON, position blades to a convenient place by turning the ignition switch ON and OFF.

(2) Lift wiper arm to raise blade off glass.

(3) Remove blade assembly from arm by inserting a small screwdriver blade into release slot of wiper blade and depressing slightly (Fig. 2), or push release button (Fig. 3).

(4) To remove wiping element from blade assembly:

- First type: pinch lock on end of blade assembly and pull wiping element (blade) out of end bridge claws (Fig. 2).

- Second type: lift tab on one end of links and squeeze the link to remove from center bridge. Slide end link off the element from claws of other link (Fig. 3).

- Third type: grasp rubber element where channel is rubber and pull rubber element and vertibra out for replacement (Fig. 4).

(5) For installation reverse above procedures.

(6) Check each release point for positive locking when installing blade element and blade assembly on vehicle.

WIPER ARM REPLACEMENT

(1) Lift the arm to permit the latch (Fig. 5) to be pulled out to the holding position then release the arm. The arm will remain off the glass in this position.

(2) Remove the arm from the pivot by using a rocking motion.

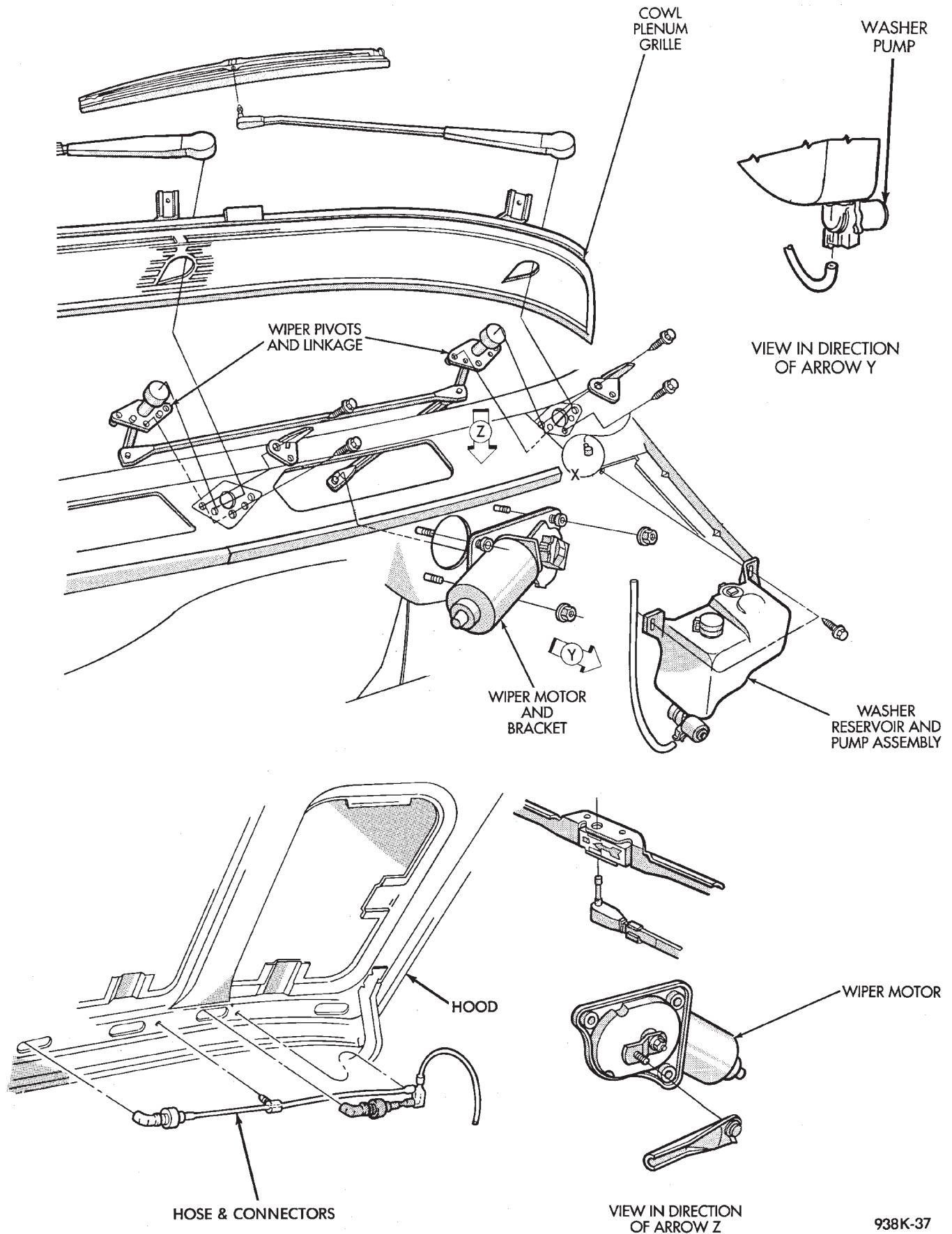

Fig. 1 Windshield Wiper System

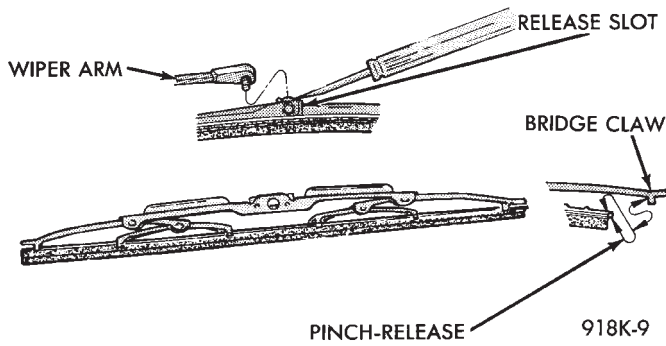

Fig. 2 Wiper Blade and Element

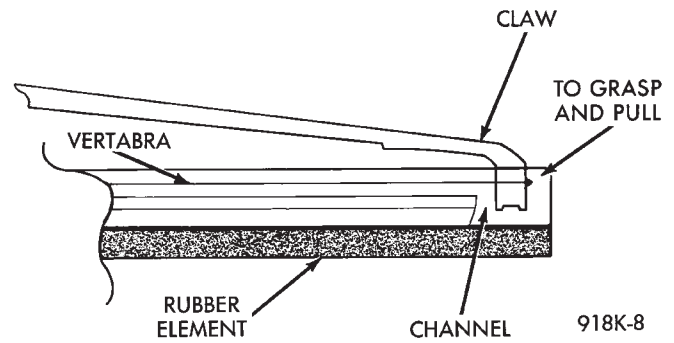

Fig. 4 Wiper Blade and Element

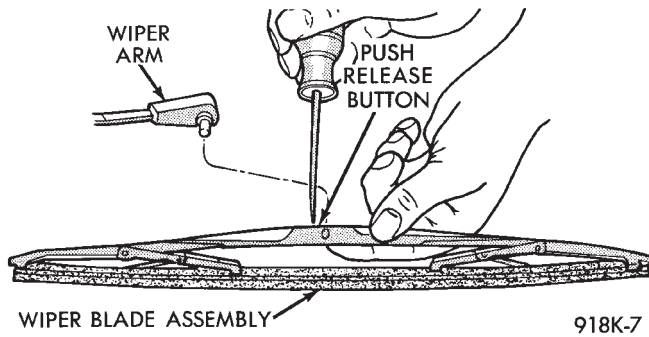

Fig. 3 Wiper Blade and Element

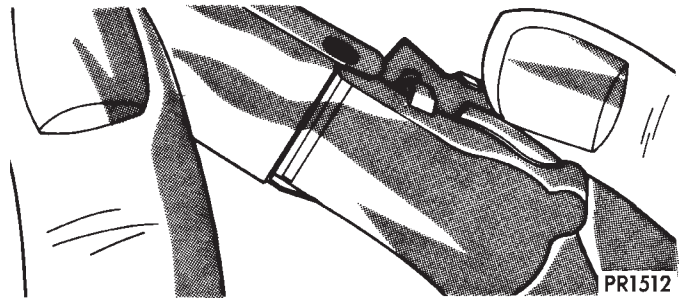

Fig. 5 Removing Wiper Arm

- (3) Set arm on pivot and push down.
- (4) Lift arm and push latch in to release arm to windshield.
- (5) For proper alignment of wiper arm, refer to Wiper Arm Adjustment.

WIPER ARM ADJUSTMENT

- (1) Cycle the wiper motor into the PARK position.
- (2) Check the tips of the blades in blackout area. From the bottom edge of the windshield to the blade should be no closer than 25 mm (1 inch) (Fig. 6).
- (3) Operate the wipers if the requirements are not met, check linkage and pivot assembly for worn parts.

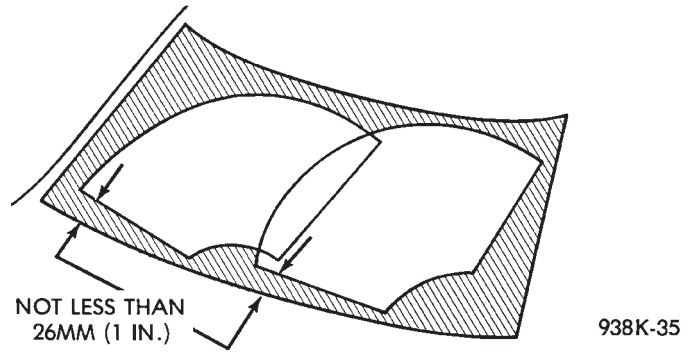

Fig. 6 Windshield Wiper Arm Adjustment

WINDSHIELD WIPER MOTOR AND LINKAGE

INDEX

| | page | | page |
|-------------------|------|-------------------------------|------|
| Motor Tests | 4 | Wiper Motor Replacement | 7 |

WARNING: ON VEHICLES EQUIPPED WITH AIRBAG, SEE GROUP 8M, RESTRAINT SYSTEMS FOR STEERING WHEEL OR COLUMN REMOVAL PROCEDURES.

The following is a list of general wiper motor system problems. The tests are to be performed to locate the faulty part and the corrective action to be taken. These tests will cover both two speed and intermittent wipe functions, refer to Windshield Wiper Motor Diagnosis (Fig. 7).

MOTOR TESTS

CONDITION: MOTOR WILL NOT RUN IN ANY SWITCH POSITION

REPAIR

- (1) Check for a blown fuse in the fuse block.
 - (a) If fuse is good, go to step 2.
 - (b) If fuse is defective, replace and check motor operation in all switch positions.
 - (c) If motor is still inoperative and the fuse does not blow, go to step 2.
 - (d) If replacement fuse blows, go to step 5.
- (2) Place switch in LOW speed position.
- (3) Listen to motor. If you cannot hear it running, go to Step No. 4. If you hear it running, check motor output shaft. If output shaft is not turning, replace motor assembly. If it is turning, drive link to output shaft or linkage is not properly connected. Replace worn parts and/or properly connect drive link to the motor output shaft.
- (4) Connect a voltmeter between motor terminal 3 and ground strap (Fig. 8). If there is no voltage or very little voltage (less than one volt) present, move negative test lead from the ground strap to negative battery terminal.
 - (a) If an increase in voltage is noticed, the problem is a bad ground circuit. Make sure the motor mounting is free of paint and that nuts or bolts are tight.
 - (b) If there is still no indication of voltage, the problem is an open circuit in the wiring harness or wiper switch.

- (c) If no noticeable increase greater than 3 volts is observed, the problem is a faulty motor assembly.
- (5) Disconnect motor wiring connector and replace fuse. Place wiper switch in all positions.

- (a) If fuse does not blow, motor is defective.
- (b) If fuse blows, switch or wiring is at fault.

CONDITION: MOTOR RUNS SLOWLY AT ALL SPEEDS

REPAIR

- (1) Disconnect wiring harness connector at motor. Remove wiper arms and blades. Connect an ammeter between battery (B+) and terminal 3 on motor (Fig. 9).
 - (a) If motor runs and average ammeter reading is more than 6 amps, go to step 2.
 - (b) If motor runs and average ammeter reading is less than 6 amps, go to step 3.
- (2) Check to see if wiper linkage or pivots are binding or caught. Disconnect drive link from motor.
 - (a) If motor now runs and draws less than 3 amps, repair linkage system.
 - (b) If motor continues to draw more than 3 amps, replace motor assembly.
- (3) Check motor wiring harness for shorting between high and low speed wires as follows:
 - (a) Connect a voltmeter or test lamp to motor ground strap.
 - (b) Set wiper switch to LOW position.
 - (c) Connect other lead of voltmeter to terminal 4 of the wiring harness.
 - (d) If voltage is present, there is a short in the wiring or wiper switch.
 - (e) If no voltage is present set wiper switch to HIGH position.
 - (f) Move voltmeter lead from terminal 4 to terminal 3 of the wiring harness.
 - (g) If voltage is present, there is a short in the wiring or wiper switch.
 - (h) If no voltage is present, check the ground strap for a good connection. If ground is OK, replace motor.

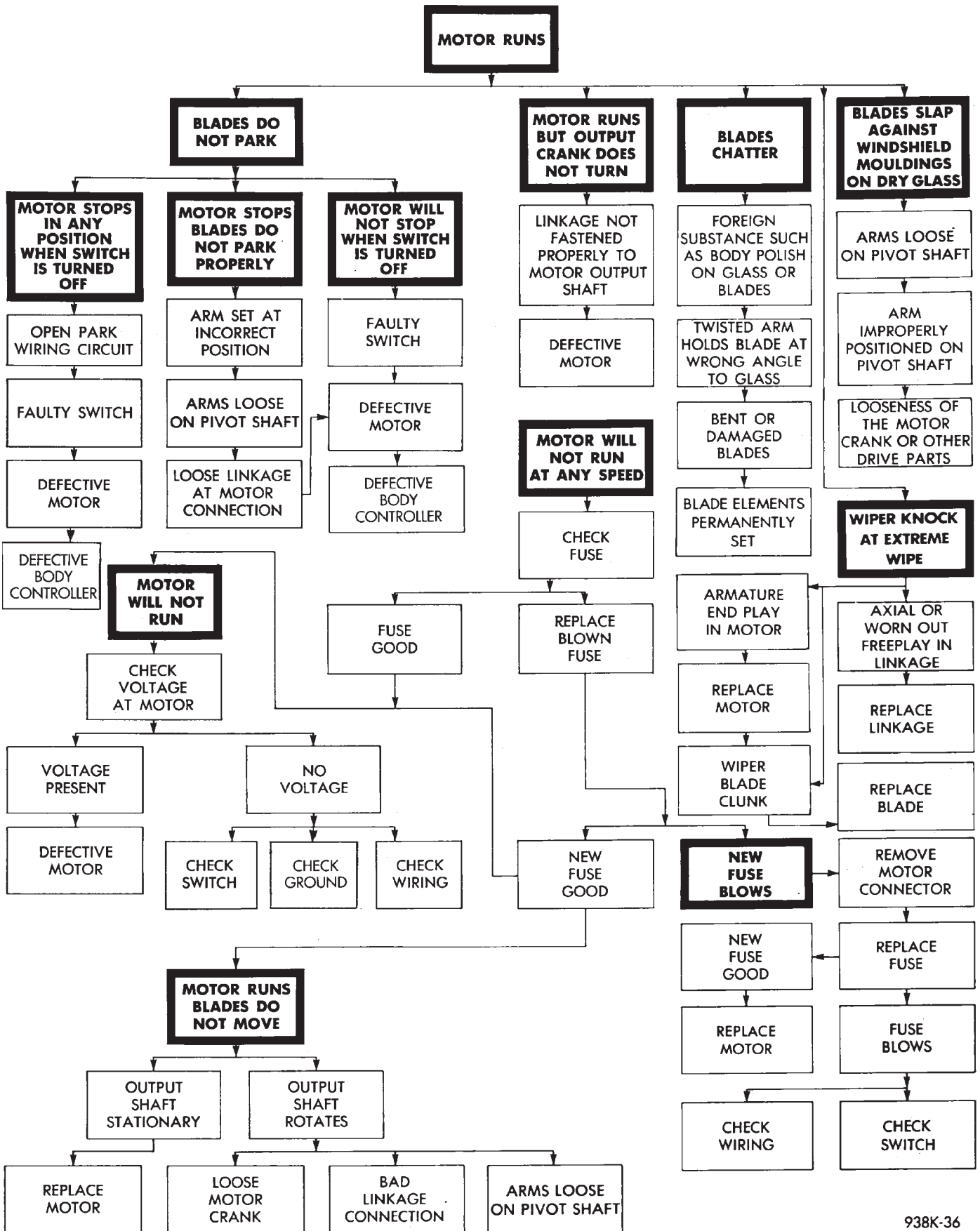

Fig. 7 Windshield Wiper Motor Diagnosis

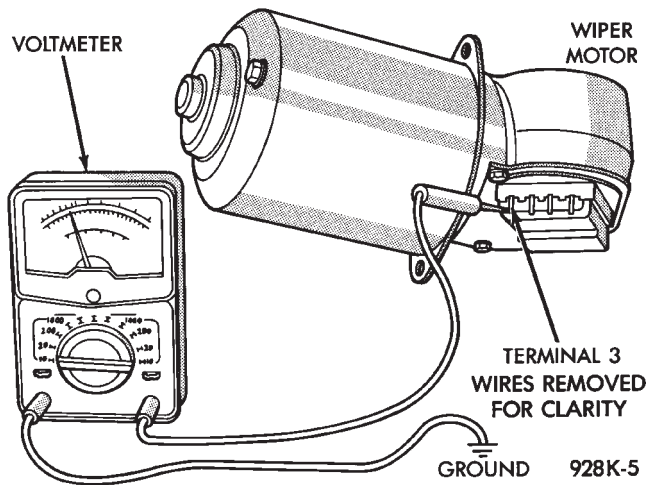

Fig. 8 Voltmeter Between Terminal 3 and Ground

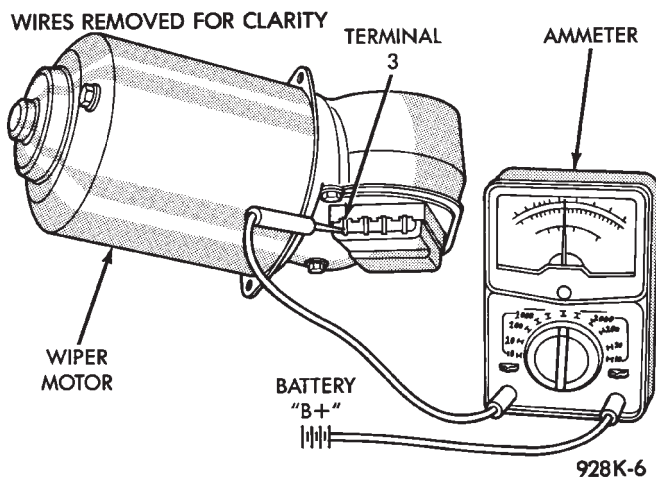

Fig. 9 Ammeter Between Terminal 3 and Battery

CONDITION: MOTOR WILL RUN AT HIGH SPEED, BUT NOT AT LOW SPEED OR MOTOR WILL RUN AT LOW SPEED, BUT NOT AT HIGH SPEED.

REPAIR

(1) If motor will not run on high speed, put switch in HIGH position and connect a test lamp between motor Terminal 4 and ground (Fig. 10).

(2) If motor will not run on low speed, put switch in LOW position and connect a test lamp between motor Terminal 3 and ground.

(3) If test lamp does not light at motor terminal, there is an open in wiring or switch. If test lamp lights at motor terminal, replace motor assembly.

CONDITION: MOTOR KEEP RUNNING WITH SWITCH IN OFF POSITION

REPAIR

(1) Remove wiring harness. Connect jumper from Terminal 1 to Terminal 3 of wiper motor (Fig. 11).

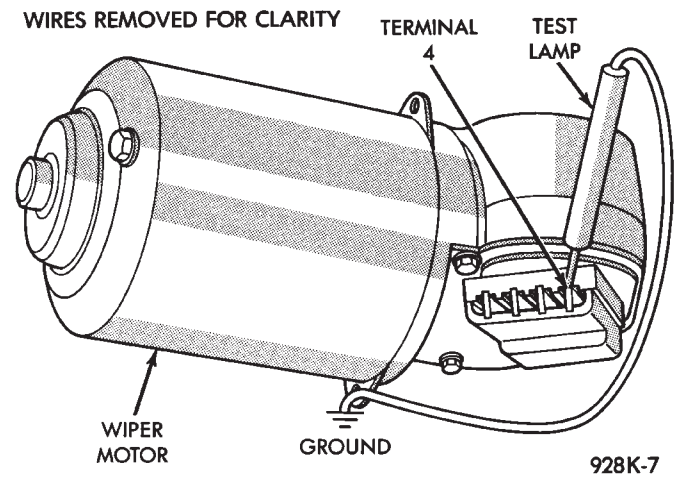

Fig. 10 Test Lamp Between Terminal 4 and Ground

Connect second jumper from Terminal 2 to battery (B+). If motor runs to PARK position and stops, go to step 2. If motor keeps running and does not park, replace motor assembly.

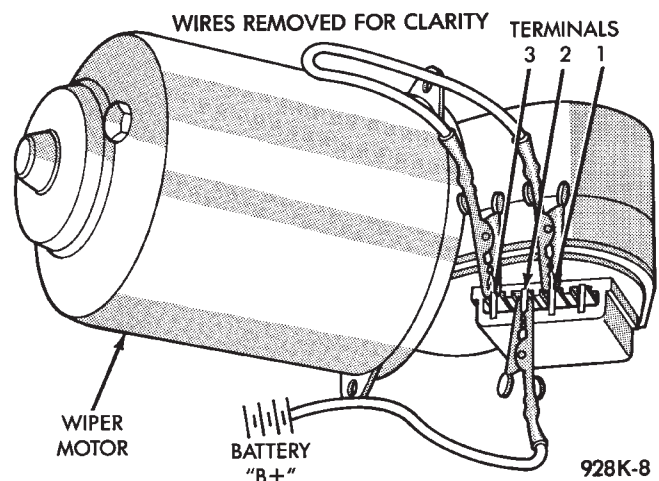

Fig. 11 Jumper Wire Between Terminal 1 and 3

(2) Reconnect wiring to motor. Disconnect blue connector from the body controller. Turn ignition OFF, using an ohmmeter, measure the continuity between terminal 22 and 24 of the body controller (Fig. 12).

(a) If there is continuity, replace body controller.

(b) If no continuity, check for an open/short circuit in wiring between terminal 22 and 24, repair as necessary. If wiring OK, refer to Multi-Function Switch Test—Wiper

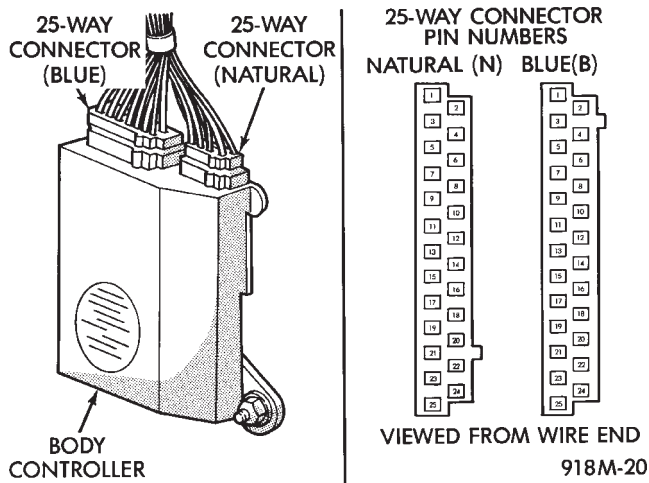

Fig. 12 Combination Controller 25-Way Connectors

CONDITION: MOTOR WILL STOP, WHEN SWITCH IS SET IN OFF POSITION. WIPERS DO NOT CONTINUE RUNNING TO PARK POSITION.

REPAIR

(1) Remove motor wiring connector and clean terminals. Reconnect connector and test motor. If problem persists, go to Step 2.

(2) Set wiper switch to OFF position. Disconnect motor wiring connector. Connect a voltmeter or test lamp to the motor ground strap. Connect the other lead to terminal 2 of wiring connector.

(a) If voltage is not present, check for an open circuit in the wiring harness.

(b) If voltage is present, go to step 3.

(3) Using an ohmmeter, check continuity between terminals 3 and 1 of the motor wire harness connector.

(a) If there is continuity between these terminals, the problem is a defective motor.

(b) If there is no continuity, the problem is an open circuit in the wiper control switch, body controller or wiring harness.

(4) Ignition OFF, disconnect body controller. Check for continuity between pin 20 and 24 of the body controller blue connector (Fig. 12). If no continuity, replace body controller.

(5) If continuity OK, disconnect the multi-function switch connector. The switch in the OFF position, check continuity between terminal 6 and 7 of the switch. If no continuity, replace multi-function switch. If continuity OK, an open in the wiring exist, repair as necessary.

WIPER MOTOR REPLACEMENT

(1) Remove windshield wiper arms (Fig. 5).

(2) Open hood assembly.

(3) Remove cowl top plenum grille.

(4) Remove hoses from hose connectors.

(5) Remove cowl plenum chamber plastic screen.

(6) Remove wiper pivot retaining screws.

(7) Push pivots down into plenum chamber.

(8) Remove nut from wiper motor output shaft and remove linkage assembly.

(9) Disconnect wiper motor wiring harness.

(10) Remove mounting screw and nuts from wiper motor.

(11) Remove wiper motor.

(12) Perform disassembly and service on pieces as necessary.

(13) For installation reverse above procedures. Except the following torque specifications:

(a) Tighten motor mounting screw and nuts 7 to 8 N•m (60 to 70 in. lbs.) torque.

(b) Tighten pivot screws 7 to 8 N•m (60 to 70 in. lbs.) torque.

(c) Position wiper motor drive crank on motor shaft and tighten retaining nut 10 to 11 N•m (90 to 100 in.lbs.) torque.

(d) Refer to Wiper Arm Adjustment for proper alignment.



INTERMITTENT WINDSHIELD WIPER MOTOR AND SWITCH

INTERMITTENT WIPER MOTOR TEST

Intermittent Wiper Motor Service Procedures for diagnosis of problems which, do not involve the delay function, refer to the Motor Tests. The two-speed functions of all wiper motors are identical.

If a problem occurs, only in the DELAY mode, the following tests are to be performed.

CONDITION: EXCESSIVE DELAY OF MORE THAN 30 SECONDS OR INADEQUATE VARIATION IN DELAY

REPAIR

Variations in delay should be as follows:

- (1) Minimum delay, control to the extreme counterclockwise position before first detent, should be one half to two seconds.
- (2) Maximum delay, control to extreme clockwise position before off detent, should be fifteen to twenty five seconds.
- (3) If there is excessive delay or no variations in delay go to intermittent wiper switch test.
- (4) If not within specification, replace body controller.

CONDITION: IN DELAY MODE WIPERS RUN CONTINUALLY WHEN WASH IS OPERATED BUT DO NOT PROVIDE AN EXTRA WIPE WHEN THE WASH CONTROL IS RELEASED

REPAIR

Replace the body controller.

CONDITION: WIPERS START ERRATICALLY DURING DELAY MODE

REPAIR

- (1) Check that the ground connection at the instrument panel is making good connection, free from paint and is tight.
- (2) Check that the motor ground strap is making good contact and that the motor mounting bolts are tight.
- (3) Check the ground connections for the intermittent wiper control unit and the wiper switch are tight.
- (4) Using an DRB II, check the intermittent wiper level input to body controller.
- (5) If condition is not corrected, replace body controller.

MULTI-FUNCTION SWITCH TEST—WIPER

WARNING: ON VEHICLES EQUIPPED WITH AIR-BAG, SEE GROUP 8M, RESTRAINT SYSTEMS FOR STEERING WHEEL OR COLUMN REMOVAL PROCEDURES.

The intermittent wipe function is controlled by the body controller, located at the lower right side of steering column. If the body controller is determined to be the problem, refer to Group 8E, Instrument Panels and Gauges, for replacement procedures.

To test the intermittent wipe functions a DRB II will be needed, and the Body Diagnostic Procedures Manual.

The DRB II is used to monitor the intermittent wipe input, washer input and the dwell switch input.

To test the switch, first disconnect the switch wires from the body wiring in the steering column. Using an ohmmeter, test for continuity between the terminals of the switch, as indicated in the following continuity chart. The identity of each terminal is shown in Fig. 13.

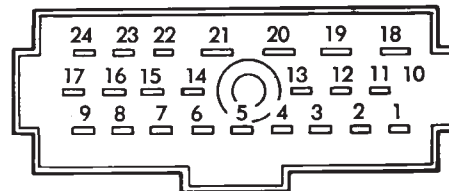

MULTIFUNCTION SWITCH PINS

| SWITCH POSITION | CONTINUITY BETWEEN |
|---|--|
| OFF | PIN 6 AND PIN 7 |
| DELAY | PIN 8 AND PIN 9 PIN 2 AND PIN 4 PIN 1 AND PIN 2 PIN 1 AND PIN 4 |
| LOW | PIN 4 AND PIN 6 |
| HIGH | PIN 4 AND PIN 5 |
| WASH | PIN 3 AND PIN 4 |
| * RESISTANCE AT MAXIMUM DELAY POSITION SHOULD BE BETWEEN 210,000 OHMS AND 390,000 OHMS. * RESISTANCE AT MINIMUM DELAY POSITION SHOULD BE ZERO WITH OHMMETER SET ON HIGH OHM SCALE. | |

928J-3

Fig. 13 Multi-Function Switch Continuity Test

For test purposes, the first position is the OFF position, next is the slide for the DELAY wipe. LOW is the next detent position and HIGH is the full counterclockwise detent position.

In any wiper mode, if the knob is pushed all the way in, the washer circuit will be completed.

The wiper switch is part of the multi-function switch assembly. If the wiper switch fails, the multi-function switch must be replaced. Refer to Group 8J, Turn Signals and Hazard Warning Flasher for multi-function switch service procedure.

WINDSHIELD WASHERS

INDEX

| | page | | page |
|---------------------------|------|---|------|
| General Information | 9 | Washer Reservoir Pump Replacement | 9 |
| Washer Nozzle | 10 | Washer Reservoir Removal | 9 |

GENERAL INFORMATION

All models are equipped with electric operated windshield washer pumps.

The wash function can be accessed in the OFF position of the wiper control switch. Holding the wash button depressed when the switch is in the OFF position will operate the wipers and washer motor pump continuously until the washer button is released. Releasing the button will stop the washer pump. The wipers will complete the current wipe cycle followed by an average of two more wipe cycles (±1) before the wipers park and the module turns off.

Whenever a windshield washer malfunction occurs, verify that the windshield washer wire harness is properly connected before starting normal diagnosis and repair procedures. Refer to Windshield Washer Diagnosis Chart (Fig. 14).

WASHER RESERVOIR REMOVAL

- (1) Unlock and open the hood.

- (2) Remove screws attaching the reservoir in plenum.

- (3) Disconnect the wiring harness from the reservoir pump and sensor, if equipped.

- (4) Disconnect the washer hose and block the liquid outlet to prevent the liquid from running out while removing the reservoir from engine compartment.

- (5) For installation reverse above procedures. Tighten attaching screws to 3 N•m (26 in. lbs.) torque.

WASHER RESERVOIR PUMP REPLACEMENT

- (1) Remove washer reservoir and pump assembly, refer to Reservoir Removal.

- (2) Notice position of pump, then using a 19mm (3/4 in.) socket through the liquid filler opening, loosen the pump filter and nut.

- (3) Disconnect the outside portion of the pump.

- (4) Remove inner and outer portions of the pump.

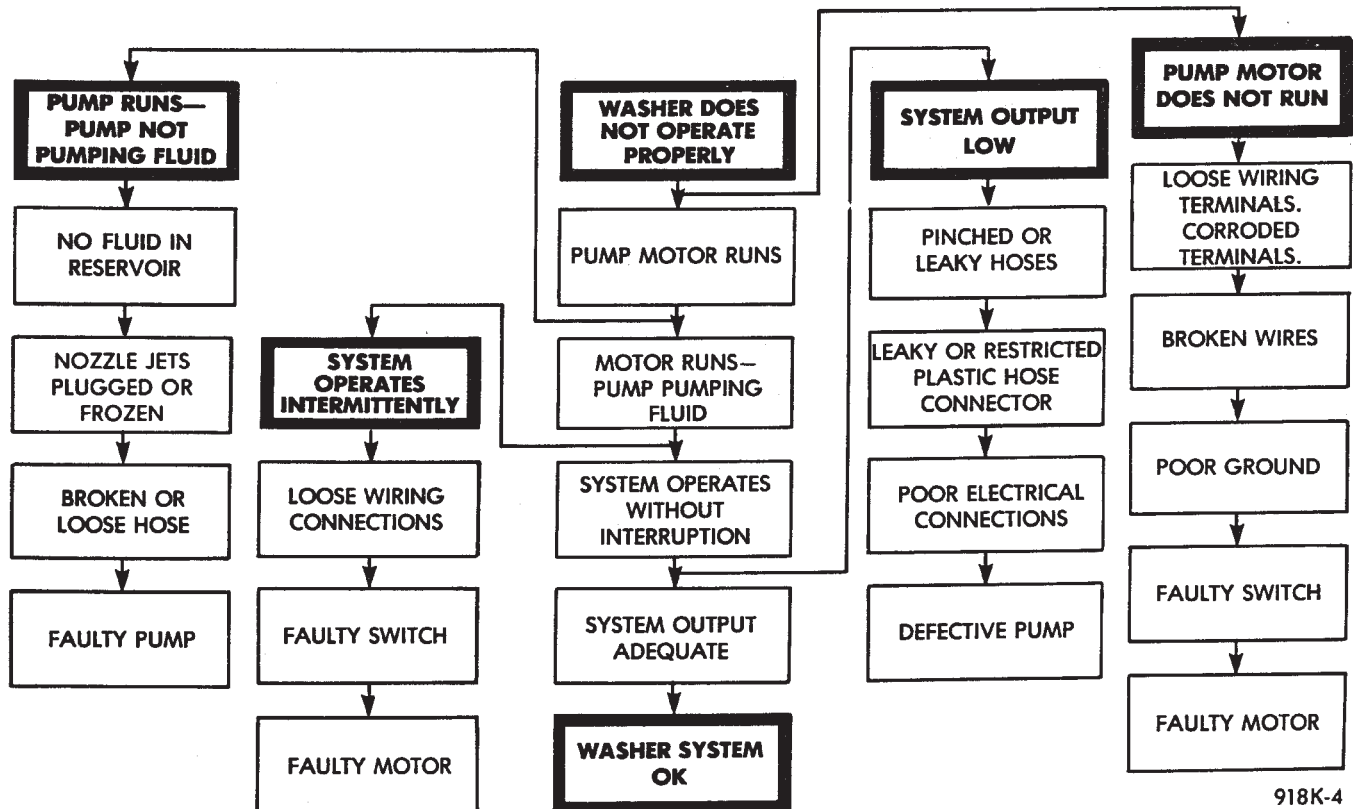

918K-4

Fig. 14 Windshield Washer Diagnosis

(5) For installation reverse above procedures.

(a) Install rubber grommet into place in bottom of reservoir.

(b) Refer to Washer Reservoir Removal for installation of reservoir.

WASHER NOZZLE

These models are equipped with two hood mounted washer nozzles. Each nozzle emits two streams into the wiper pattern (Fig. 15). If nozzle performance is unsatisfactory they can be adjusted. To adjust insert a pin into the nozzle ball and move to proper pattern (Fig. 16). The right and left nozzles are identical.

To replace nozzle, disconnect washer fluid hose. Using a needle nose pliers, squeeze together the locking tabs on the nozzle. When installing make sure that both locking tabs are securely snapped into position. Connect washer fluid hose

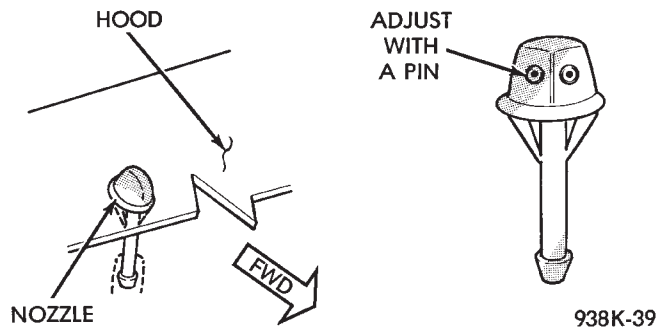

Fig. 15 Windshield Washer Nozzle

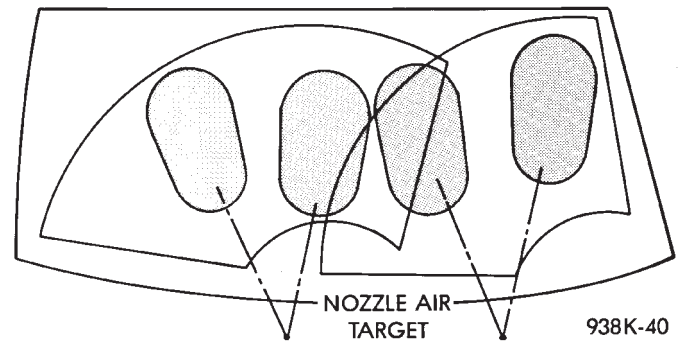

Fig. 16 Windshield Washer Pattern

REAR WINDOW WIPER/WASHER SYSTEM

INDEX

| | page | | page |
|--|------|--|------|
| Liftgate Motor Replacement | 13 | Rear Window Intermittent Wipe Module Location | 11 |
| Liftgate Washer Reservoir Pump Replacement | 13 | Rear Wiper/Washer Control Pod Switch | 12 |
| Liftgate Washer Reservoir Removal | 13 | Rear Wiper/Washer Control Pod Switch Replacement | 12 |
| Liftgate Wiper Motor Test | 12 | Washer Nozzle | 13 |
| Module Test | 11 | | |
| Rear Arm Adjustment | 11 | | |

For wiper blade service, refer to windshield Wiper Blades.

REAR ARM ADJUSTMENT

(1) With the motor in park position, mount the arm on the motor shaft. Choose a serration engagement that properly locates tip of the blade about 90 mm (3 1/2 inch) parallel, with lower edge of liftgate glass (Fig. 17).

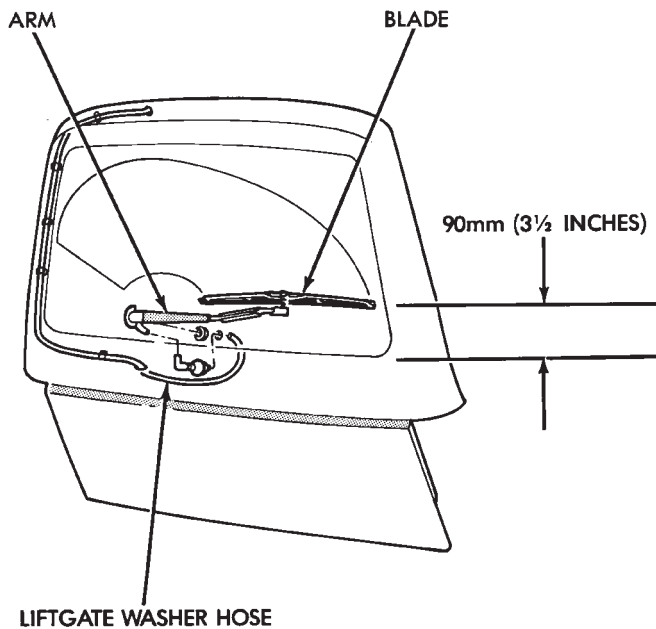

928K-11

Fig. 17 Installing Liftgate Wiper Arm

(2) Operate the wiper on dry glass with the engine off. The tip of the wiper blade should be within 60 mm (2 3/8 inch) to 120 mm (4 3/4 inch) above lower edge of liftgate glass.

REAR WINDOW INTERMITTENT WIPE MODULE LOCATION

The intermittent wipe module is located inside the lift gate on the right van side (Fig. 18).

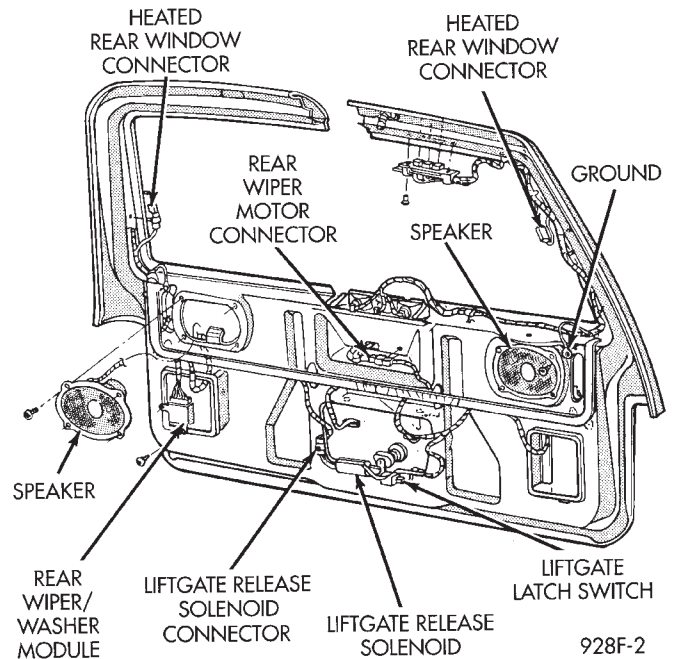
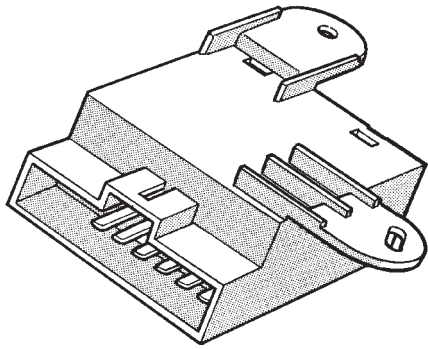

Fig. 18 Intermittent Wipe Module Location

MODULE TEST

- (1) Remove liftgate trim panel. Refer to Group 23, Body.
- (2) Using a volt/ohmmeter test each pin and repair as necessary.
 - (a) Pin 1, test for module output battery voltage to wiper motor, with the ignition switch in the ON position and the rear wiper switch ON (Fig. 19).
 - (b) Pin 2, test for battery voltage from ignition switch, with the ignition in the ON position.
 - (c) Pin 3, test for continuity to ground.
 - (d) Pin 4, ignition switch ON and the rear window washer switch ON, test for battery voltage.
 - (e) Pin 5, ignition switch ON and wiper switch ON, test for continuity to ground. The intermittent mode will have a eight second delay between wipes
 - (f) Pin 6, ignition switch ON and washer switch pushed-in, test continuity to ground.



928N-2

Fig. 19 Rear Wipe Module**REAR WIPER/WASHER CONTROL POD SWITCH**

(1) The Rear Wiper switch portion of this assembly is a push ON, push OFF latching action and provides:

- Rear wiper operates with a fixed intermittent cycle.
- A ground signal to the rear wash/wipe module to turn the rear wiper system ON (fixed intermittent) when rear wiper button is latched down.
- There shall be continuity between terminals B5 and B2 when the rear wiper button is depressed and latched down.

• When the rear wiper button is latched, the ON indicator lamp will light only when headlamps are on.

• If not replace rear wiper/washer control POD switch.

(2) The Rear Washer switch portion of this assembly is a push ON, momentary action and provides:

- A ground signal to the rear wash/wipe module to turn the rear washer system ON when the rear wash button is depressed.
- There shall be continuity between terminals B4 and B3 only when the front washer button is depressed.
- If not replace rear wiper/washer control POD switch.

(3) Serviceable: lamp control the illumination of the switch assembly. The lamp is feed by terminals B6 (power) and B5 (ground).

REAR WIPER/WASHER CONTROL POD SWITCH REPLACEMENT

(1) Remove warning indicator grille by prying up with a flat blade tool.

(2) Remove three mounting screws from the warning indicator module assembly.

(3) Remove eight screws mounting the cluster bezel to the instrument panel.

(4) Tilt column down if possible for ease.

(5) Gently pull cluster bezel out, to gain access to the switch assembly's snap fingers and push switch out through mounting hole for POD switch assembly (Fig. 20).

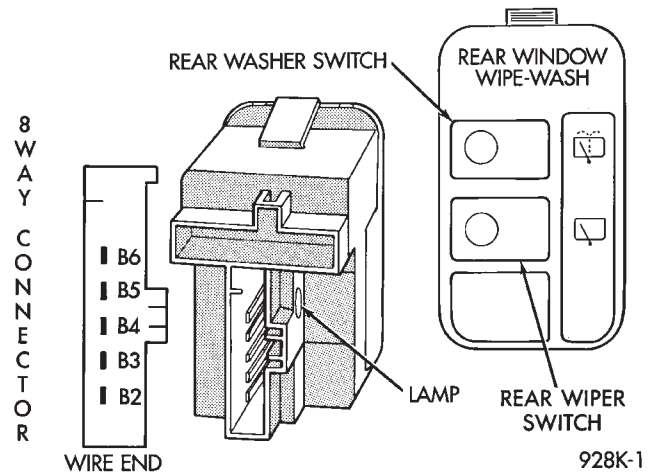
**Fig. 20 Rear Wiper/Washer Control POD Switch**

(6) Remove wiring connectors for POD switch assembly.

(7) Remove lamp.

(8) For installation reverse above procedures. Verify the functions of the front and rear wipe/wash system.

LIFTGATE WIPER MOTOR TEST

The following test is used to locate and then repair liftgate wiper motor defects. Refer to Group 8W, Wiring Diagrams for liftgate wiper motor wiring schematic.

(1) Disconnect feed wire connector from wiper motor (Fig. 21).

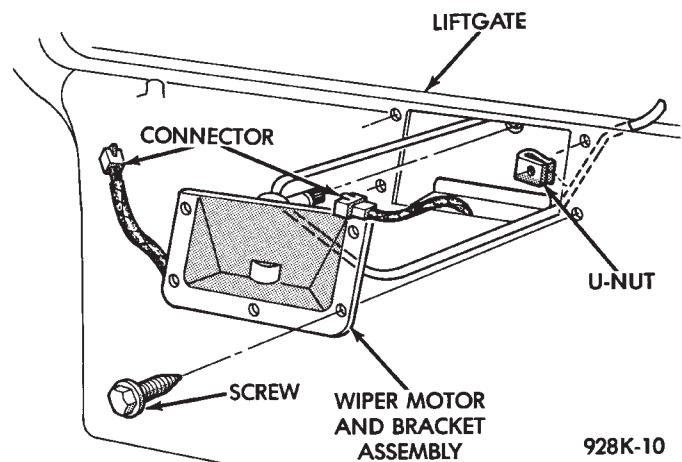

928K-10

Fig. 21 Liftgate Wiper Motor and Bracket Assembly

(2) With ignition switch in ON position, check for battery voltage at the brown wire with pink tracer.

(3) With ignition switch in ON position and wiper switch ON, check for battery voltage at both wires. If battery voltage is not present in steps 2 and 3, check fuse, liftgate wiper switch and wiring and wiper module.

(4) With ignition switch in ON position, and wiper switch in OFF position, check for battery voltage be-

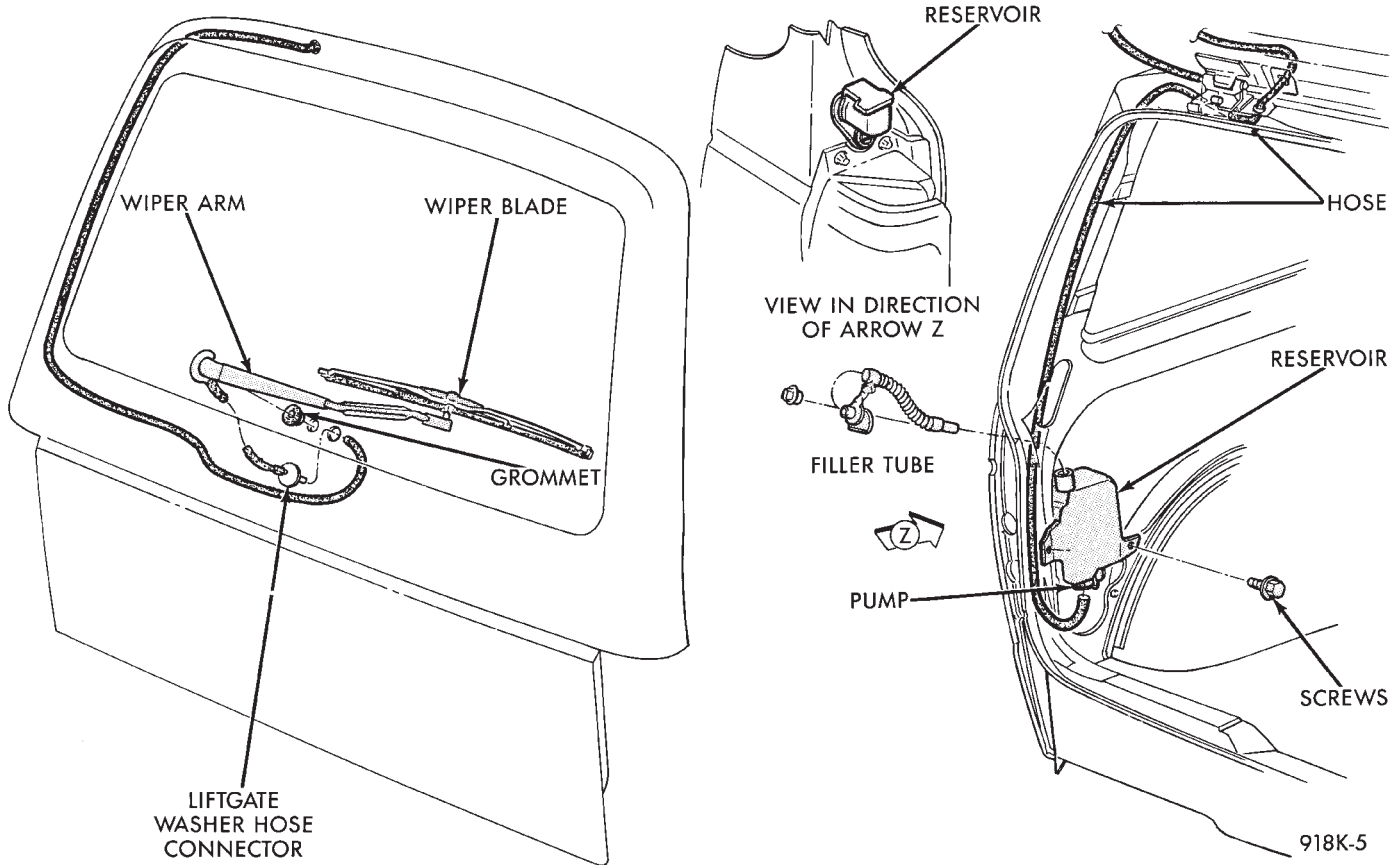

Fig. 22 Liftgate Washer System

tween both wires. If battery voltage is not present check ground wire to wiper module.

(5) If battery voltage is present in steps 2 and 3, replace motor.

LIFTGATE MOTOR REPLACEMENT

(1) Remove liftgate wiper arm assembly, refer to Wiper Arm Replacement.

(2) Unlock and open the liftgate.

(3) Remove liftgate trim panel, refer to Group 23, Liftgate Trim Panel Removal.

(4) Remove five liftgate motor mounting screws (Fig. 21).

(5) Disconnect wiring harness from liftgate motor connector.

(6) Remove motor assembly from liftgate.

(7) For installation reverse above procedures.

(a) Install five liftgate motor mounting screws. Tighten 3 to 5 N•m (25 to 45 in. lbs.) of torque.

(b) Install wiper arm assembly, refer to Wiper Arm Adjustment.

LIFTGATE WASHER RESERVOIR REMOVAL

(1) Unlock and open the liftgate.

(2) Remove two side aperture panel and reservoir mounting screws (Fig. 22).

(3) Disconnect the wiring harness from the washer pump.

(5) Disconnect the washer hose from reservoir system, block the liquid outlet to prevent the liquid from running out while removing the reservoir.

(6) Remove one upper reservoir screw.

(7) Remove reservoir and pump assembly through the side aperture panel access hole. Work filler tube off reservoir. Empty the reservoir outside of vehicle.

(8) For installation reverse above procedures.

(a) Fill reservoir and test system.

LIFTGATE WASHER RESERVOIR PUMP REPLACEMENT

(1) Remove washer reservoir and pump assembly, refer to Washer Reservoir Removal.

(2) With mechanical fingers, loosen pump filter and nut through liquid filler opening.

(3) Disconnect the outside portion of the pump.

(4) Remove inner and outer portions of the pump, and remove pump.

(5) For installation reverse above procedures.

WASHER NOZZLE

To replace unsnap nozzle from wiper arm and disconnect hose. When installing make sure that both the nozzle and the hose guard are securely snapped into position.

