

RESTRAINT SYSTEMS

CONTENTS

	page		page
AIR BAG MODULE	4	GENERAL INFORMATION	1
AIR BAG SERVICE AND TEST PROCEDURES ..	1	LEFT FRONT IMPACT SENSOR	4
AIR BAG SYSTEM CHECK	3	RIGHT FRONT IMPACT SENSOR	5
AIR BAG SYSTEM DIAGNOSTIC MODULE (ASDM)	5	SCHEDULED MAINTENANCE INSPECTION	3
CLOCKSPRING	6	STEERING COLUMN SWITCHES	8
CLOCKSPRING CENTERING PROCEDURE	6	STEERING WHEEL	7

AIR BAG SERVICE AND TEST PROCEDURES

WARNING: THIS SYSTEM IS A SENSITIVE, COMPLEX ELECTRO-MECHANICAL UNIT. BEFORE ATTEMPTING TO DIAGNOSE, REMOVE OR INSTALL THE AIR BAG SYSTEM COMPONENTS, YOU MUST FIRST DISCONNECT AND ISOLATE THE NEGATIVE (GROUND) BATTERY CABLE. FAILURE TO DO SO COULD RESULT IN ACCIDENTAL DEPLOYMENT AND POSSIBLE PERSONAL INJURY.

WHEN AN UNDEPLOYED AIR BAG ASSEMBLY IS TO BE REMOVED FROM THE STEERING WHEEL, DISCONNECT BATTERY GROUND CABLE AND ISOLATE. ALLOW SYSTEM CAPACITOR TO DISCHARGE FOR TWO MINUTES THEN BEGIN AIR BAG SYSTEM COMPONENT REMOVAL.

If the Air Bag Module Assembly is defective and non-deployed, refer to Chrysler Motors current return list for proper handling procedures.

WARNING: REPLACE AIR BAG SYSTEM COMPONENTS WITH CHRYSLER MOPAR® SPECIFIED REPLACEMENT PARTS. SUBSTITUTE PARTS MAY VISUALLY APPEAR INTERCHANGEABLE, BUT INTERNAL DIFFERENCES MAY RESULT IN INFERIOR OCCUPANT PROTECTION.

THE FASTENERS, SCREWS, AND BOLTS, ORIGINALLY USED FOR THE AIR BAG COMPONENTS, HAVE SPECIAL COATINGS AND ARE SPECIFICALLY DESIGNED FOR THE AIR BAG SYSTEM. THEY MUST NEVER BE REPLACED WITH ANY SUBSTITUTES. ANYTIME A NEW FASTENER IS NEEDED, REPLACE WITH THE CORRECT FASTENERS PROVIDED IN THE SERVICE PACKAGE OR FASTENERS LISTED IN THE PARTS BOOKS.

GENERAL INFORMATION

AIR BAG MODULE

The air bag module is the most visible part of the system (Fig 1). It contains the air bag cushion and its supporting components. The air bag module contains a housing to which the cushion and inflator are attached and sealed.

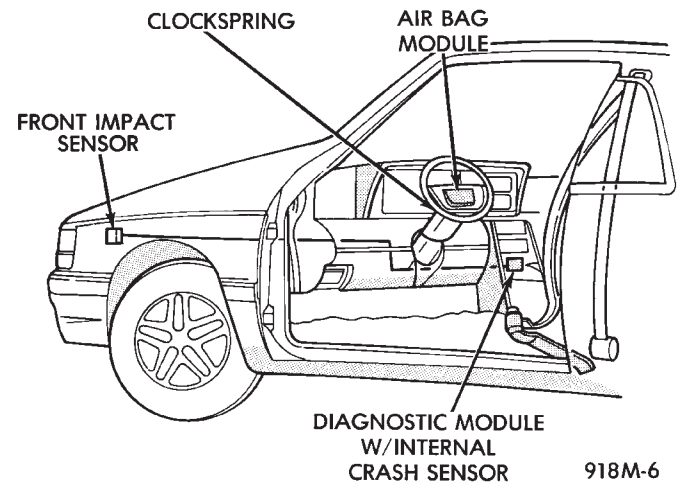

Fig. 1 Minivan Driver Air Bag System

The inflator assembly is mounted to the back of the module housing. When supplied with the proper electrical signal the inflator assembly will produce a gas and discharges it directly into the cushion. A protective cover is fitted to the front of the air bag module and forms a decorative cover in the center of the steering wheel. The air bag module is mounted directly to the steering wheel.

FRONT IMPACT SENSORS

The driver air bag system is a safety device designed to reduce the risk of fatality or serious injury, caused by a frontal impact of the vehicle.

The impact sensors provide verification of the direction and severity of the impact. Three impact sensors are used. One is called a safing sensor. It is

located inside the diagnostic module which is mounted on the floor pan, just forward of the center console. The other two sensors are mounted on the upper crossmember of the radiator closure panel on the left and right side of the vehicle under the hood.

The impact sensors are threshold sensitive switches that complete an electrical circuit when an impact provides a sufficient G force to close the switch. The sensors are calibrated for the specific vehicle and react to the severity and direction of the impact.

CLOCKSPRING

The clockspring is mounted on the steering column behind the steering wheel, and is used to maintain a continuous electrical circuit between the wiring harness and the driver's air bag module. This assembly consists of a flat ribbon-like electrically conductive tape which winds and unwinds with the steering wheel rotation.

DIAGNOSTIC MODULE

The Air Bag System Diagnostic Module (ASDM) contains the safing sensor and energy reserve capacitor. The ASDM monitors the system to determine the system readiness. The ASDM will store sufficient energy to deploy the air bag for only two minutes after the battery is disconnected. If both front impact sensors are open the air bag could be deployed up to 9.5 minutes after the battery is disconnected. The ASDM contains on-board diagnostics, and will illuminate the AIR BAG warning lamp in the cluster when a fault occurs.

STORAGE

The air bag module must be stored in its original special container until used for service. Also, it must be stored in a clean, dry environment, away from sources of extreme heat, sparks, and sources of high electrical energy. Always place or store the module on a surface with the trim cover facing up to minimize movement in case of accidental deployment.

HANDLING LIVE MODULE

At no time should any source of electricity be permitted near the inflator on the back of the module. When carrying a live module, the trim cover should be pointed away from the body to minimize injury in the event of accidental deployment. In addition, if the module is placed on a bench or other surface, the plastic trim cover should be face up to minimize movement in case of accidental deployment.

When handling a steering column with an air bag module attached, never place the column on the floor or other surface with the steering wheel or module face down.

DEPLOYED MODULE

The vehicle interior may contain a very small amount of sodium hydroxide powder, a byproduct of air bag deployment. Since this powder can irritate the skin, eyes, nose or throat, be sure to wear safety glasses, rubber gloves and long sleeves during cleanup (Fig. 2).

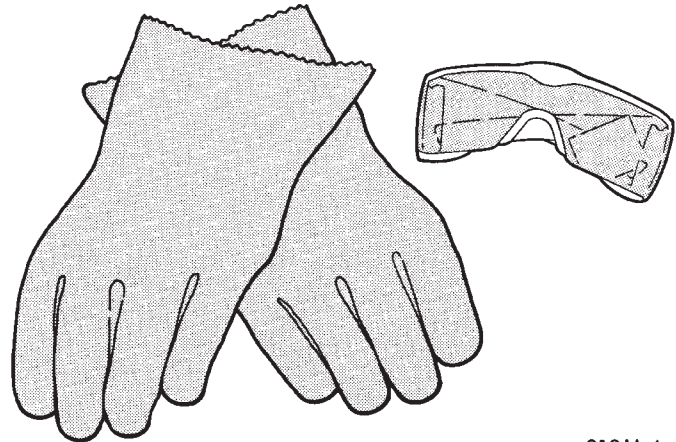

918M-4

Fig. 2 Wear Safety Glasses and Rubber Gloves

If you find that the cleanup is irritating your skin, run cool water over the affected area. Also, if you experience nasal or throat irritation, exit the vehicle for fresh air until the irritation ceases. If irritation continues, see a physician.

CLEANUP PROCEDURE

Begin the cleanup by putting tape over the two air bag exhaust vents (Fig. 3) so that no additional powder will find its way into the vehicle interior. Then remove the air bag and air bag module from the vehicle.

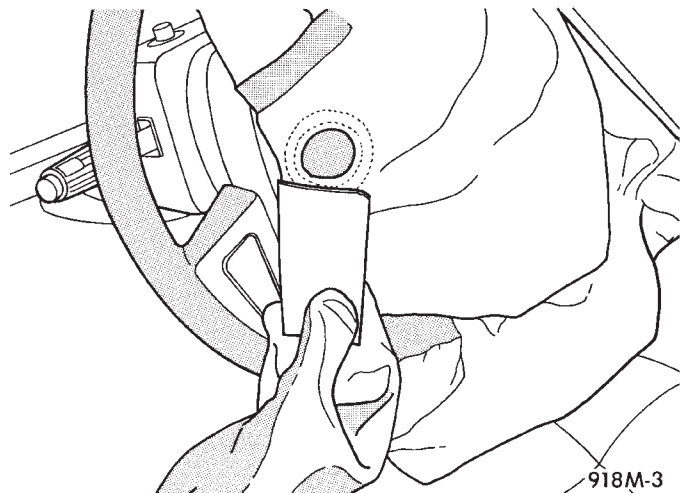

918M-3

Fig. 3 Seal the Air Bag Exhaust Vents

Use a vacuum cleaner to remove any residual powder from the vehicle interior. Work from the outside in so that you avoid kneeling or sitting in a uncleaned area.

Be sure to vacuum the heater and A/C outlets as well (Fig. 4). In fact it's a good idea to run the blower on low and to vacuum up any powder expelled from the plenum. You may need to vacuum the interior of the car a second time to recover all of the powder.

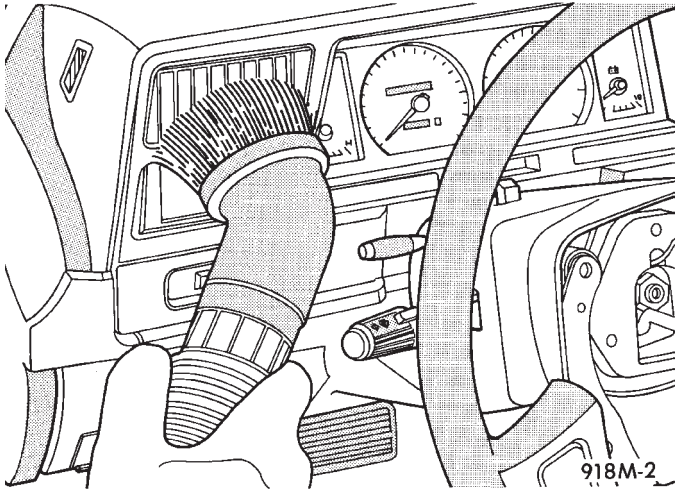

Fig. 4 Vacuum Heater and A/C Outlets

Place the deployed bag and module in your automotive scrap.

SERVICE OF DEPLOYED AIR BAG MODULE

After an air bag has been deployed, the air bag module and clockspring must be replaced because they cannot be reused. Other air bag system components are replaced if damaged.

SCHEDULED MAINTENANCE INSPECTION

Vehicles equipped with a Air Bag System, the following items should be inspected.

(1) Inspect components for damage or deterioration.

(a) If the air bag module housing shows signs of physical damage or abuse, replace the module.

(b) Check that both front impact sensors are properly installed to the upper crossmember of the radiator closure panel. Repair as required.

(2) Check the air bag warning lamp for proper operation as follows:

(a) Turn ignition switch to the ON position, the air bag warning lamp should light. If not, test the system using the DRB II and Passive Restraint System Diagnostic Procedures Manual. Repair as required.

(b) The air bag warning lamp lights, but fails to go out after ten seconds. Test the system using the DRB II and Passive Restraint System Diagnostic Procedures Manual. Repair as required.

(c) Erasing of fault codes is not required.

AIR BAG SYSTEM CHECK

WARNING: BEFORE BEGINNING ANY AIR BAG SYSTEM CHECK PROCEDURES, REMOVE AND ISOLATE THE BATTERY NEGATIVE (-) CABLE (GROUND) FROM THE VEHICLE BATTERY. THIS IS THE ONLY SURE WAY TO DISABLE THE AIR BAG SYSTEM. FAILURE TO DO THIS COULD RESULT IN ACCIDENTAL AIR BAG DEPLOYMENT AND POSSIBLE PERSONAL INJURY.

WHEN AN UNDEPLOYED AIR BAG ASSEMBLY IS TO BE REMOVED FROM THE STEERING WHEEL, DISCONNECT BATTERY GROUND CABLE AND ISOLATE. ALLOW SYSTEM CAPACITOR TO DISCHARGE FOR TWO MINUTES, THEN BEGIN AIR BAG REMOVAL.

(1) Disconnect the battery negative cable and isolate.

(2) Remove forward console or cover as necessary.

(3) Connect DRB II to ASDM diagnostic 6-way connector, located at right side of module.

(4) Turn the ignition key to ON position. Exit vehicle with DRB II. Use the latest version of the proper cartridge.

(5) After checking that no one is inside the vehicle, connect the negative battery cable.

(6) Using the DRB II, read and record active fault data.

(7) Read and record any stored faults.

(8) Refer to the Passive Restraint Diagnostic Test Manual if any faults are found in steps 6 and 7.

(9) Erase stored faults if there are no active fault codes. If problems remain, fault codes will not erase.

(10) With the ignition key in the ON position, make sure no one is in the vehicle.

(11) From the passenger side of vehicle, turn the ignition key to OFF then ON and observe the instrument cluster air bag lamp. It should go on for six to eight seconds, then go out; indicating system is functioning normally.

If air bag warning lamp either fails to light, blinks on and off or goes on and stays on, there is a system malfunction. Refer to the Passive Restraint Diagnostic Test Manual to diagnose the problem.

AIR BAG MODULE

WARNING: BEFORE BEGINNING ANY AIR BAG SYSTEM REMOVAL OR INSTALLATION PROCEDURES, REMOVE AND ISOLATE THE BATTERY NEGATIVE (-) CABLE (GROUND) FROM THE VEHICLE BATTERY. THIS IS THE ONLY SURE WAY TO DISABLE THE AIR BAG SYSTEM. FAILURE TO DO THIS COULD RESULT IN ACCIDENTAL AIR BAG DEPLOYMENT AND POSSIBLE PERSONAL INJURY.

UNDEPLOYED AIR BAG REMOVAL FROM THE STEERING WHEEL: DISCONNECT BATTERY GROUND CABLE AND ISOLATE. ALLOW SYSTEM CAPACITOR TO DISCHARGE FOR TWO MINUTES. BEGIN AIR BAG REMOVAL.

REMOVAL

When removing a deployed module, rubber gloves, eye protection and long sleeve shirt should be worn, as there may be deposits on the surface which could irritate the skin and eyes.

- (1) Disconnect battery negative cable and isolate.
- (2) Wait two minutes for the reserve capacitor to discharge before removing undeployed module.
- (3) Remove four nuts attaching air bag module to steering wheel (Fig. 5).

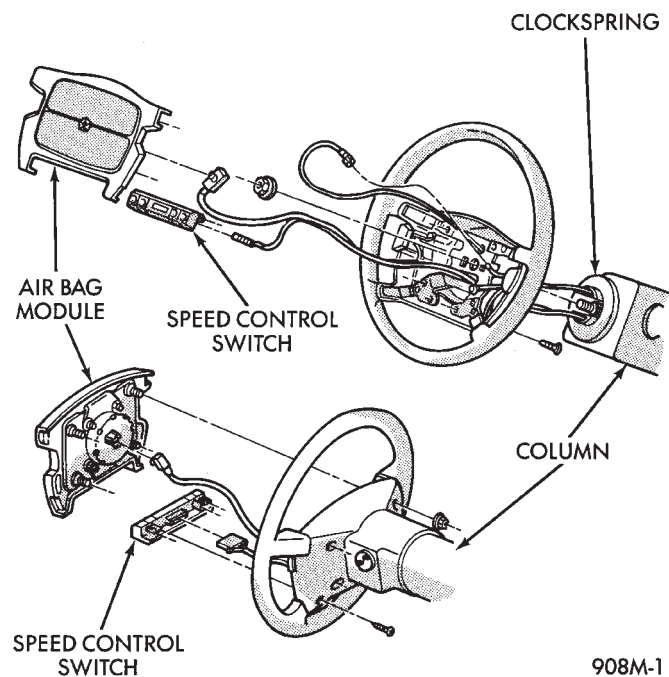

Fig. 5 Air Bag Module

- (4) Lift module, and disconnect electrical connector from rear of module.
- (5) Remove module.
- (6) When replacing a deployed module, the clockspring must also be replaced. Refer to Clockspring Removal and Installation for proper procedure.

INSTALLATION

- (1) Connect clockspring squib connector to the module, by pressing straight in on the connector.
- (2) Install four nuts and tighten to 9 to 11 N•m (80 to 100 in. lbs.) torque.
- (3) Do not connect battery negative cable. Refer to Air Bag System Check for proper procedure.

LEFT FRONT IMPACT SENSOR

REMOVAL

WARNING: BEFORE BEGINNING ANY AIR BAG SYSTEM REMOVAL OR INSTALLATION PROCEDURES, REMOVE AND ISOLATE THE BATTERY NEGATIVE (-) CABLE (GROUND) FROM THE VEHICLE BATTERY. THIS IS THE ONLY SURE WAY TO DISABLE THE AIR BAG SYSTEM. FAILURE TO DO THIS COULD RESULT IN ACCIDENTAL AIR BAG DEPLOYMENT AND POSSIBLE PERSONAL INJURY.

- (1) Disconnect battery negative cable and isolate.
- (2) Remove three nuts holding sensor to upper crossmember of radiator closure panel and remove sensor (Fig. 6).

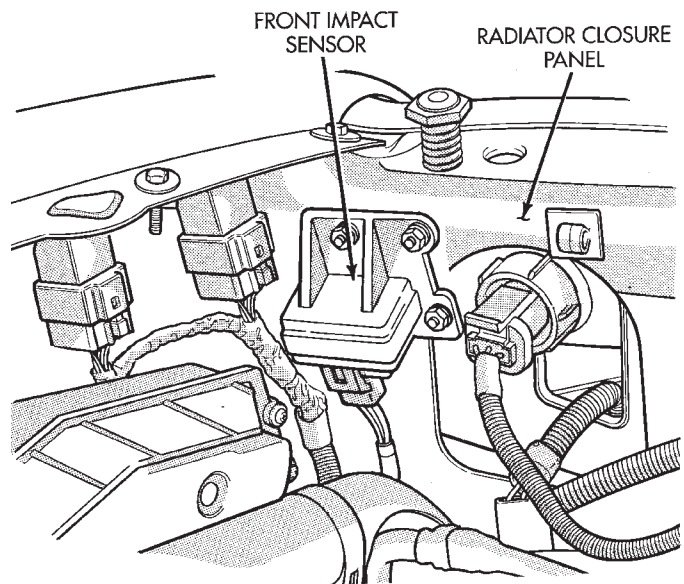

Fig. 6 Left Impact Sensor

- (3) Disconnect impact sensor electrical connector.

INSTALLATION

- (1) Connect sensor wiring lead from harness to connector on body of sensor.
- (2) Install left sensor with arrow pointing forward (Fig. 6) and tighten nuts to 4.5 to 7 N•m (40 to 60 in. lbs.) torque using nuts provided with the new sensor.



(3) Do not connect battery negative cable. Refer to Air Bag Systems Check for proper procedure.

RIGHT FRONT IMPACT SENSOR

REMOVAL

- (1) Disconnect battery negative cable and isolate.
- (2) Remove three nuts holding sensor to upper crossmember of radiator closure panel. Remove right sensor.
- (3) Disconnect impact sensor electrical connector (Fig. 7).

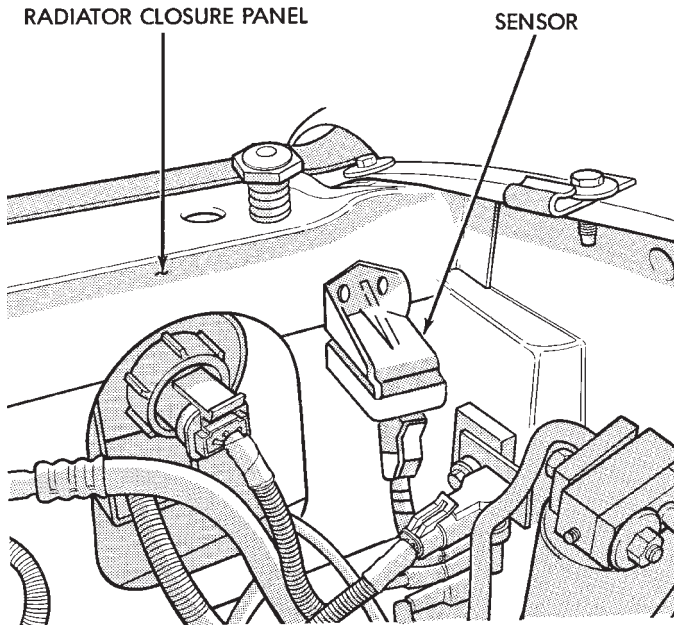

938M-14

Fig. 7 Right Impact Sensor

INSTALLATION

- (1) Connect sensor wiring lead from harness to connector on body of sensor.
- (2) Install right sensor with arrow pointing forward (Fig. 6) and tighten nuts to 4.5 to 7 N•m (40 to 60 in. lbs.) torque using nuts provided with the new sensor.
- (3) Do not connect battery negative cable. Refer to Air Bag Systems Check for proper procedure.

AIR BAG SYSTEM DIAGNOSTIC MODULE (ASDM)

WARNING: THE ASDM CONTAINS ONE OF THE IMPACT SENSORS WHICH ENABLE THE SYSTEM TO DEPLOY THE AIR BAG. TO AVOID ACCIDENTAL DEPLOYMENT, NEVER CONNECT ASDM ELECTRICALLY TO THE SYSTEM WHILE VEHICLE BATTERY IS CONNECTED. BEFORE BEGINNING ANY AIR BAG SYSTEM REMOVAL OR INSTALLATION PROCEDURES, REMOVE AND ISOLATE THE BATTERY NEGATIVE (-) CABLE (GROUND) FROM THE VEHICLE BATTERY. THIS IS THE ONLY SURE WAY TO DISABLE THE AIR BAG SYSTEM. FAILURE TO DO

THIS COULD RESULT IN ACCIDENTAL AIR BAG DEPLOYMENT, AND POSSIBLE PERSONAL INJURY.

REMOVAL

- (1) Disconnect battery negative cable, and isolate cable.
- (2) Remove forward console or cover as necessary (Fig. 8 and 9).

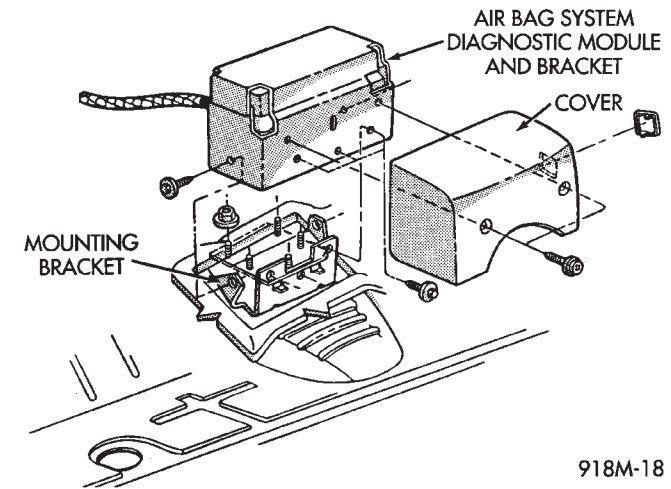

Fig. 8 Air Bag System Diagnostic Module

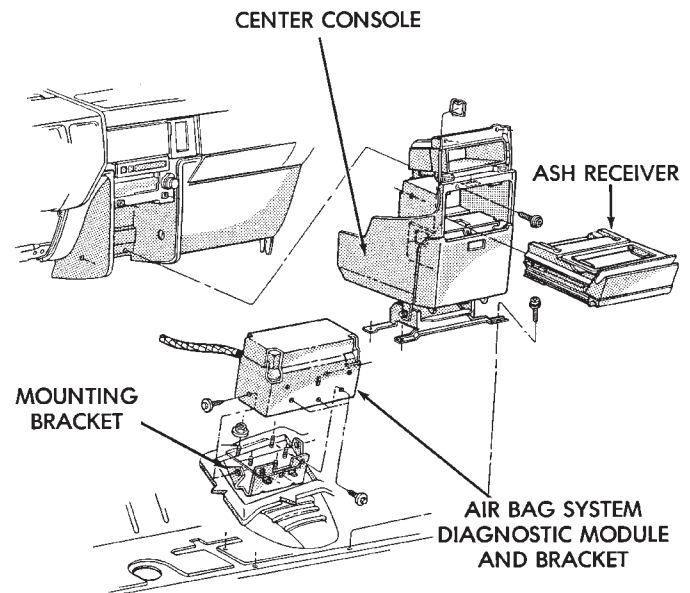

Fig. 9 Air Bag System Diagnostic Module with Center Console

- (3) Remove five module and bracket mounting screws, and lift module carefully up and rearward.
- (4) Disconnect wiring at ASDM and remove module.

918M-17

INSTALLATION

(1) Position module and bracket facing forward. Connect wiring connectors and ensure they are locked into position.

(2) Place the module and bracket on the lower mounting bracket, using locating tab to position module.

(3) Attach module and bracket with screws and tighten to 4 N•m (35 in. lbs.) torque.

CAUTION:USE SUPPLIED SCREWS

(4) Install forward console.

(5) Do not connect battery negative cable. Refer to Air Bag System Check for proper procedure.

CLOCKSPRING

WARNING: BEFORE BEGINNING ANY AIR BAG SYSTEM REMOVAL OR INSTALLATION PROCEDURES, REMOVE AND ISOLATE THE BATTERY NEGATIVE (-) CABLE (GROUND) FROM THE VEHICLE BATTERY. THIS IS THE ONLY SURE WAY TO DISABLE THE AIR BAG SYSTEM. FAILURE TO DO SO COULD RESULT IN ACCIDENTAL AIR BAG DEPLOYMENT, AND POSSIBLE INJURY.

WHEN AN UNDEPLOYED AIR BAG ASSEMBLY IS TO BE REMOVED FROM THE STEERING WHEEL, DISCONNECT BATTERY GROUND CABLE AND ISOLATE. ALLOW SYSTEM CAPACITOR TO DISCHARGE FOR 2 MINUTES, THEN BEGIN AIR BAG REMOVAL.

REMOVAL

(1) Place the front wheels in the straight ahead position before starting the repair.

(2) Disconnect battery negative cable and isolate.

(3) Wait two minutes for the reserve capacitor to discharge before removing undeployed module.

(4) Remove the air bag module.

(5) Remove Speed Control switch and connector if so equipped or cover.

(6) Disconnect horn terminals.

(7) Remove the steering wheel.

(8) Remove upper and lower steering column shrouds to gain access to clockspring wiring.

(9) Disconnect the 2-way connector between the clockspring and the instrument panel wiring harness on top of the fuse block.

(10) To remove, pull clockspring assembly from the steering column by lifting locating fingers as necessary. The clockspring cannot be repaired, and must be replaced if faulty.

INSTALLATION

(1) Snap clockspring onto the steering column. If the clockspring is not properly positioned, follow the clockspring centering procedure before installing steering wheel.

(2) Connect the clockspring to the instrument panel harness, ensure wiring locator clips are properly seated on wiring trough. Ensure harness locking tabs are properly engaged.

(3) Install steering column shrouds. Be sure air bag wire is inside of shrouds.

(4) Front wheels should still be in the straight-ahead position. Install steering wheel, ensure the flats on hub align with clockspring. Pull the horn lead through the smaller upper hole. Pull the air bag and speed control leads through the larger bottom hole. Ensure leads are not pinched under the steering wheel.

(5) Connect the horn lead wire, then the air bag lead wire to the air bag module.

(6) Install the air bag module and tighten nuts to 9 to 11 N•m (80 to 100 in. lb.) torque.

(7) Install speed control switch and connector or cover.

(8) Do not connect battery negative cable. Refer to Air Bag Systems Check for proper procedure.

CLOCKSPRING CENTERING PROCEDURE

If the rotating tape within the clockspring is not positioned properly with the steering wheel and the front wheels, the clockspring may fail during use. The following procedure MUST BE USED to center the clockspring if it is not known to be properly positioned, or if the front wheels were moved from the straight ahead position.

WARNING: BEFORE BEGINNING ANY AIR BAG SYSTEM REMOVAL OR INSTALLATION PROCEDURES, REMOVE AND ISOLATE THE BATTERY NEGATIVE (-) CABLE (GROUND) FROM THE VEHICLE BATTERY. THIS IS THE ONLY SURE WAY TO DISABLE THE AIR BAG SYSTEM. FAILURE TO DO THIS COULD RESULT IN ACCIDENTAL AIR BAG DEPLOYMENT AND POSSIBLE INJURY.

WHEN AN UNDEPLOYED AIR BAG ASSEMBLY IS TO BE REMOVED FROM THE STEERING WHEEL, DISCONNECT BATTERY GROUND CABLE AND ISOLATE. ALLOW SYSTEM CAPACITOR TO DISCHARGE FOR TWO MINUTES, THEN BEGIN AIR BAG REMOVAL.

(1) Place front wheels in the straight ahead position.

(2) Wait two minutes for the reserve capacitor to discharge before removing undeployed module.

(3) Refer to Steering Wheel procedures for removal of air bag module and steering wheel.



(4) Depress the two plastic locking pins to disengage locking mechanism (Fig. 10).

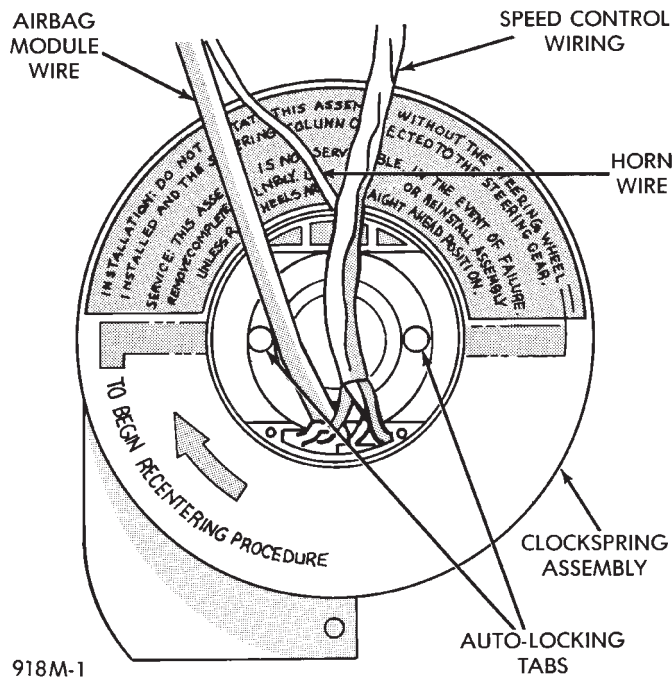

Fig. 10 Clockspring (Auto-Locking)

(5) Keeping locking mechanism disengaged, rotate the clockspring rotor in the **CLOCKWISE DIRECTION** to the end of travel. Do not apply excessive torque.

(6) From the end of travel, rotate the rotor two full turns and a half in the counterclockwise direction. The horn wire should end up at the top and the squib wire at the bottom. Engage clockspring locking mechanism.

(7) Refer to Steering Wheel procedures for installation of steering wheel and air bag module.

(8) Do not connect battery negative cable. Refer to Air Bag System Check for proper procedure.

STEERING WHEEL

WARNING: BEFORE BEGINNING ANY AIR BAG SYSTEM REMOVAL OR INSTALLATION PROCEDURES, REMOVE AND ISOLATE THE BATTERY NEGATIVE (-) CABLE (GROUND) FROM THE VEHICLE BATTERY. THIS IS THE ONLY SURE WAY TO DISABLE THE AIR BAG SYSTEM. FAILURE TO DO THIS COULD RESULT IN ACCIDENTAL AIR BAG DEPLOYMENT AND POSSIBLE PERSONAL INJURY.

WHEN AN UNDEPLOYED AIR BAG ASSEMBLY IS TO BE REMOVED FROM THE STEERING WHEEL, DISCONNECT BATTERY GROUND CABLE AND ISOLATE. ALLOW SYSTEM CAPACITOR TO DISCHARGE FOR TWO MINUTES. BEGIN AIR BAG REMOVAL.

REMOVAL

- (1) Make sure front wheels are straight, and steering column is locked in place.
- (2) Disconnect battery negative cable and isolate.
- (3) Wait two minutes for the reserve capacitor to discharge before removing undeployed module.
- (4) Remove four nuts attaching air bag module from the back side of steering wheel.
- (5) Lift module, and disconnect connector from rear of module.
- (6) Remove speed control switch and connector if so equipped or cover.
- (7) Remove steering wheel retaining nut.
- (8) Remove steering wheel with steering wheel puller Tool C-3428B.

INSTALLATION

- (1) If the clockspring is not properly positioned or if front wheels were moved, follow the clockspring centering procedure before installing steering wheel. With the front wheels in the straight ahead position. Position the steering wheel on the steering column. Making sure to fit the flats on the hub of the steering wheel with the formations on the inside of the clockspring. Pull the air bag and speed control wires through the lower, larger hole in the steering wheel and the horn wire through smaller hole at the top. Make sure not to pinch wires (Fig. 11).

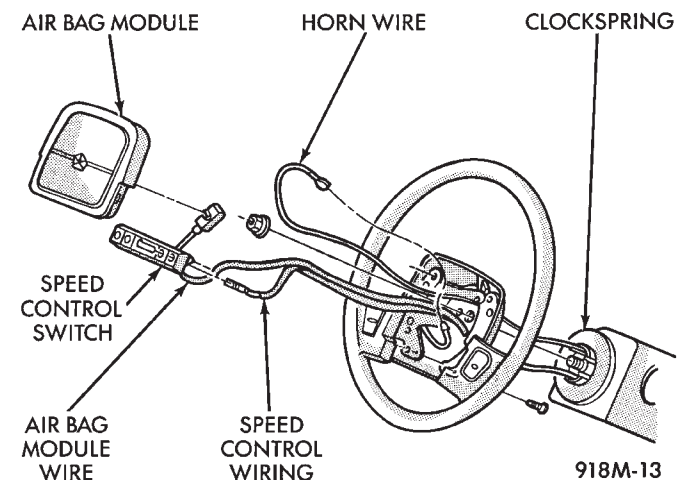

Fig. 11 Steering Wheel Wiring

- (2) Install retaining nut, and tighten it to 61 N•m (45 ft. lbs.) torque.
- (3) Connect horn wiring lead.
- (4) Connect 4-way connector to speed control switch and attach switch to steering wheel.
- (5) Connect air bag lead wire to air bag module, and secure module to steering wheel.
- (6) Do not connect negative battery cable. Refer to Air Bag System Check for proper procedure.

STEERING COLUMN SWITCHES

This procedure covers the removal and installation of the steering wheel and clockspring. Once the steering wheel and clockspring have been removed, refer to the appropriate section of this service manual for switch replacement.

WARNING: BEFORE BEGINNING ANY AIR BAG SYSTEM REMOVAL OR INSTALLATION PROCEDURES, REMOVE AND ISOLATE THE BATTERY NEGATIVE (-) CABLE (GROUND) FROM THE VEHICLE BATTERY. THIS IS THE ONLY SURE WAY TO DISABLE THE AIR BAG SYSTEM. FAILURE TO DO THIS COULD RESULT IN ACCIDENTAL AIR BAG DEPLOYMENT AND POSSIBLE INJURY.

WHEN AN UNDEPLOYED AIR BAG ASSEMBLY IS TO BE REMOVED FROM THE STEERING WHEEL, DISCONNECT BATTERY GROUND CABLE AND ISOLATE. ALLOW SYSTEM CAPACITOR TO DISCHARGE FOR TWO MINUTES. BEGIN AIR BAG REMOVAL.

REMOVAL

- (1) Disconnect battery negative cable, and isolate.
- (2) Wait two minutes for the reserve capacitor to

discharge before removing undeployed module.

- (3) Remove four nuts attaching air bag module from the back side of steering wheel.
- (4) Lift module, and disconnect connector from rear of module.
- (5) Remove speed control switch and connector if so equipped or cover.
- (6) Remove steering wheel.
- (7) Unsnap clockspring, and remove it.
- (8) Refer to the appropriate section for switch replacement.

INSTALLATION

- (1) Snap clockspring on to steering column. Assure the 4-way connector is still seated.
- (2) Install steering wheel.
- (3) Install speed control switch and connector or cover.
- (4) Connect clockspring wiring connector to the module.
- (5) Install four nuts to module, and tighten to 9 to 11 N•m (80 to 100 in. lbs.) torque.
- (6) Do not connect negative battery cable. Refer to Air Bag System Check for proper procedure.